

(19) (KR)
(12) (B1)

(51) 。 Int. Cl.7
A47J 31/40

(45)
(11)
(24)

2003 11 05
10-0404601
2003 10 24

(21) 10-2001-0024734
(22) 2001 05 07

(65)
(43)

2002-0085304
2002 11 16

(73) 658-3

(72) 658-3

(74)
:

(54)

가
(210) , (301) (100) (210), (230) (300) ;
; / (222) ;

1

, , , ,

1
2
3 2
4a 4c
5

* *
44 : 55 :

88: 130:
100 : 210 :
220 : 230 :
310: 320 :
330: 360 :
400: 410:

가

가 가

가

가

, 1996 10 10

(300) ; (222) ; (210) ; (301) ; (100) ; (210), (230)

(110) ; (130) ; (120) 가

(440) ,

(460)

가

(410) ; (420) , (400) , (420)

1 , 3 2 , 4a 4c , 2 , 5

가 1

가

(15,16) (100)

(60) (80) (70) (20)

(40) (50) (90)

(30) (17)

(170)가 (160) (140) (300) (220)가 가 (190) (100)

가 2 (200ml) (310) (230) (310) (300) (22)

0) 2 (220) (210) (222)

PCB ()

가 30) (360) (340)가 (350) (320) 5(가) (310) (3)

() 가

가 가 가

가

(340)가 (370)

(350) (330)가 (310)가 (350)가 (370)

(350) 가 (310)가 (360) (350)가 (350)가

5()

B () (390) 0.1mm;3

80) B ,B B A 가 A B 가 B

가

가

4a (110) (130)

(120)

(130) 가

(110) 가 (150)

4 4

4b
(410) 가 , (400) 가
(410) 가 (420) 가 (410)
, 가 (400) (430)
가 4c , (440) (210)
가 가 (460)
1 가
가 (460) 가 (450)
, 가 가
, 0.5 0.8g
, (88)가
" " ,
가 30
, 가

, 가 가 가 /
, , ,
, 가 가 가
, 가 가

(57)
1.
(301) (210), (230) (300) ; (210)
(100) (110) (130)
(120) 가
(222) ;
; , /

2.

3.

1 , (440) , (450)
(460) ,

4.

1 , 가 , (420) ,
(400) , (410)
(420)

5.

4 , 4 ,

6.

- 1 , (330) , (370) ,
- (350) , (340) , (310) (360) ,
- 7. 가
- 6 가
- 8. (310)가
- 9. (385) ,
- 1 5 ,
- 10. 가
- 9 ,
- 11. 가 ()
- 1 12.
- 13.
- 14.
- 15.
- 16.
- 17.

1

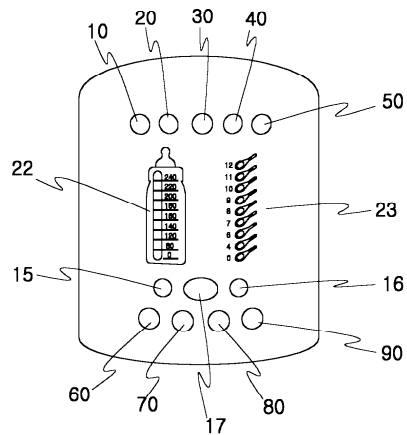
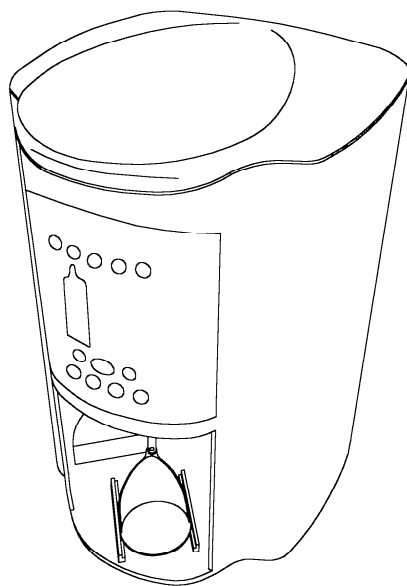

2

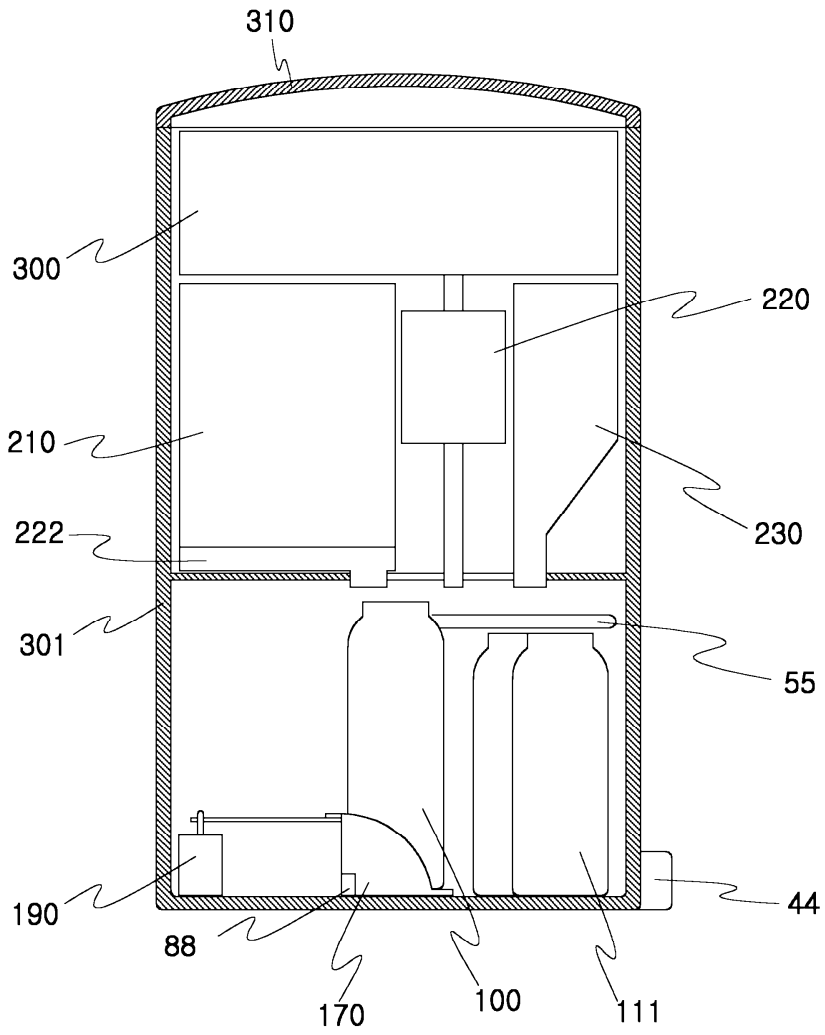

3

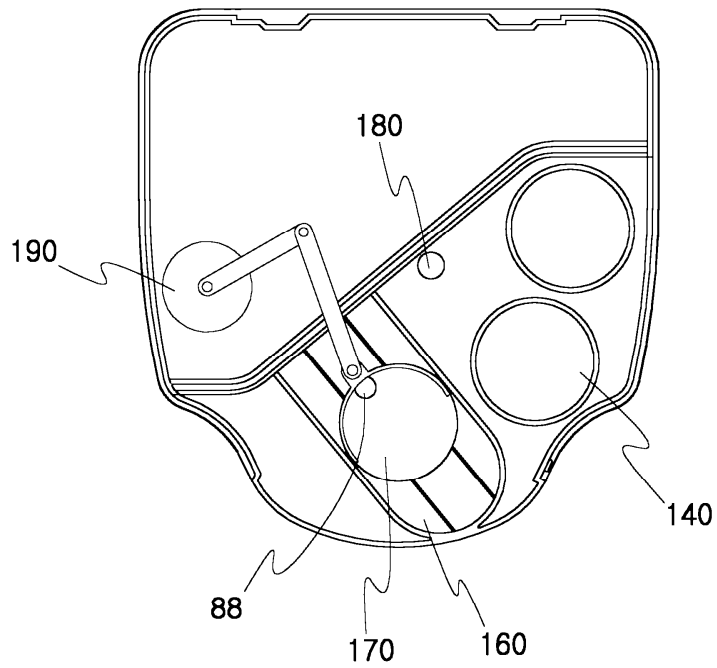

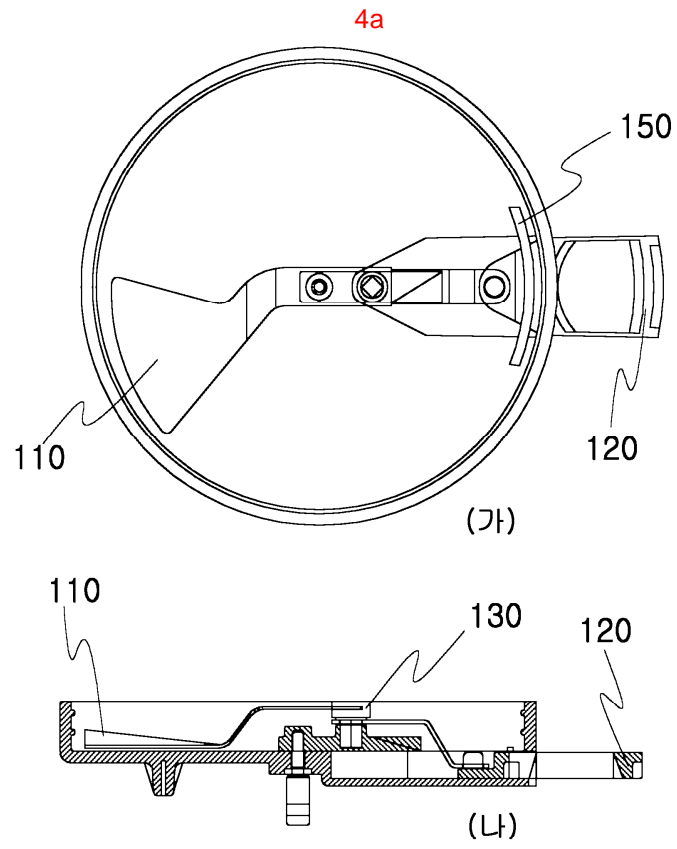

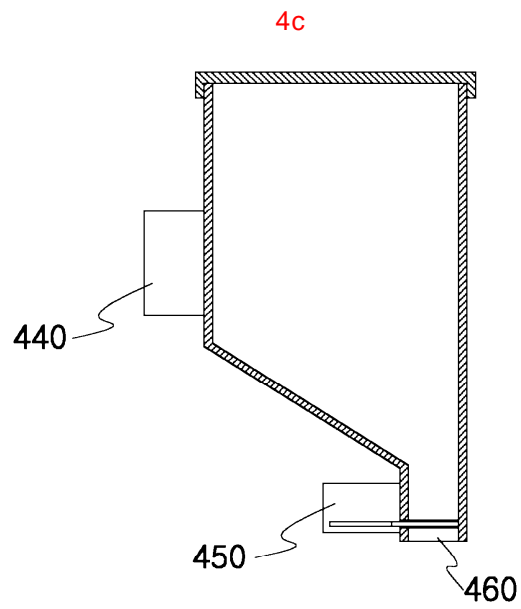
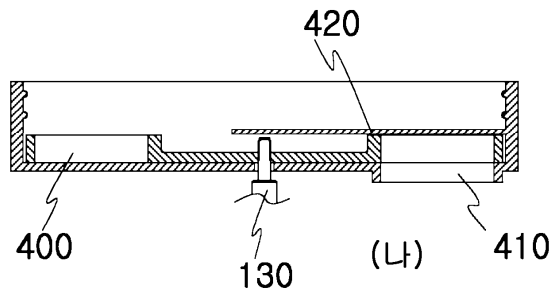
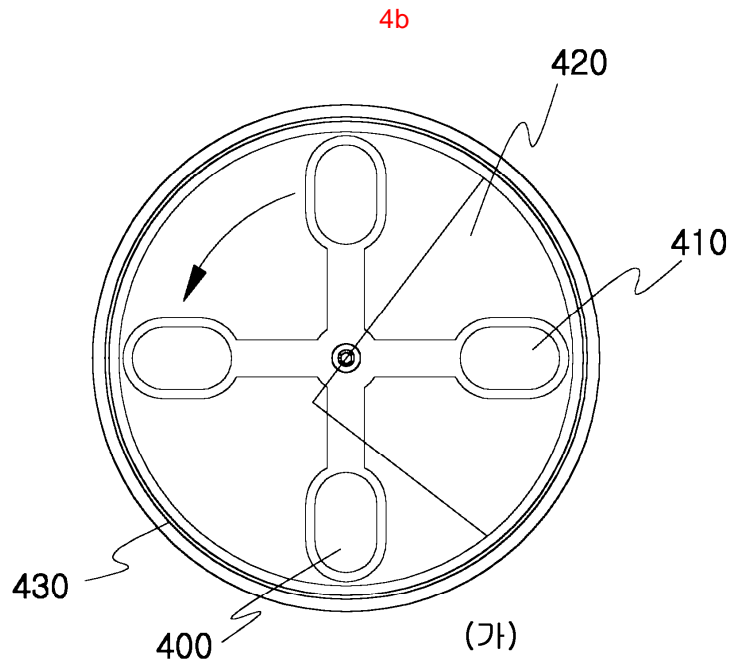

5

