



(51) International Patent Classification:

C09K 11/64 (2006.01) H01J 61/44 (2006.01)
C09K 11/61 (2006.01) H01L 33/50 (2010.01)
C09K 11/59 (2006.01)

(21) International Application Number:

PCT/US2012/043426

(22) International Filing Date:

21 June 2012 (21.06.2012)

(25) Filing Language:

English

(26) Publication Language:

English

(30) Priority Data:

13/170,615 28 June 2011 (28.06.2011) US

(71) Applicant (for all designated States except US):

GENERAL ELECTRIC COMPANY [US/US]; 1 River Road, Schenectady, NY 12345 (US).

(72) Inventors; and

(75) Inventors/Applicants (for US only):

NAMMALWAR, Prasanth, Kumar [IN/IN]; One Research Circle, Bldg. K1-3A59, Niskayuna, NY 12309 (US). SETLUR, Anant, Achyut [US/US]; One Research Circle, Bldg. K1-3A59, Niskayuna, NY 12309 (US). POROB, Digamber, Gurusdas [IN/IN]; One Research Circle, Bldg. K1-3A59, Niskayuna, NY 12309 (US). MANEPALLI, Satya, Kis-

hore [IN/IN]; One Research Circle, Bldg. K1-3A59, Niskayuna, NY 12309 (US).

(74) Agents: DIMAURO, Peter, T. et al.; General Electric Company, Global Patent Operation, 2 Corporate Drive, Suite 648, Shelton, CT 06484 (US).

(81) Designated States (unless otherwise indicated, for every kind of national protection available): AE, AG, AL, AM, AO, AT, AU, AZ, BA, BB, BG, BH, BR, BW, BY, BZ, CA, CH, CL, CN, CO, CR, CU, CZ, DE, DK, DM, DO, DZ, EC, EE, EG, ES, FI, GB, GD, GE, GH, GM, GT, HN, HR, HU, ID, IL, IN, IS, JP, KE, KG, KM, KN, KP, KR, KZ, LA, LC, LK, LR, LS, LT, LU, LY, MA, MD, ME, MG, MK, MN, MW, MX, MY, MZ, NA, NG, NI, NO, NZ, OM, PE, PG, PH, PL, PT, QA, RO, RS, RU, RW, SC, SD, SE, SG, SK, SL, SM, ST, SV, SY, TH, TJ, TM, TN, TR, TT, TZ, UA, UG, US, UZ, VC, VN, ZA, ZM, ZW.

(84) Designated States (unless otherwise indicated, for every kind of regional protection available): ARIPO (BW, GH, GM, KE, LR, LS, MW, MZ, NA, RW, SD, SL, SZ, TZ, UG, ZM, ZW), Eurasian (AM, AZ, BY, KG, KZ, RU, TJ, TM), European (AL, AT, BE, BG, CH, CY, CZ, DE, DK, EE, ES, FI, FR, GB, GR, HR, HU, IE, IS, IT, LT, LU, LV, MC, MK, MT, NL, NO, PL, PT, RO, RS, SE, SI, SK, SM, TR), OAPI (BF, BJ, CF, CG, CI, CM, GA, GN, GQ, GW, ML, MR, NE, SN, TD, TG).

[Continued on next page]

(54) Title: PHOSPHOR MATERIALS AND RELATED DEVICES

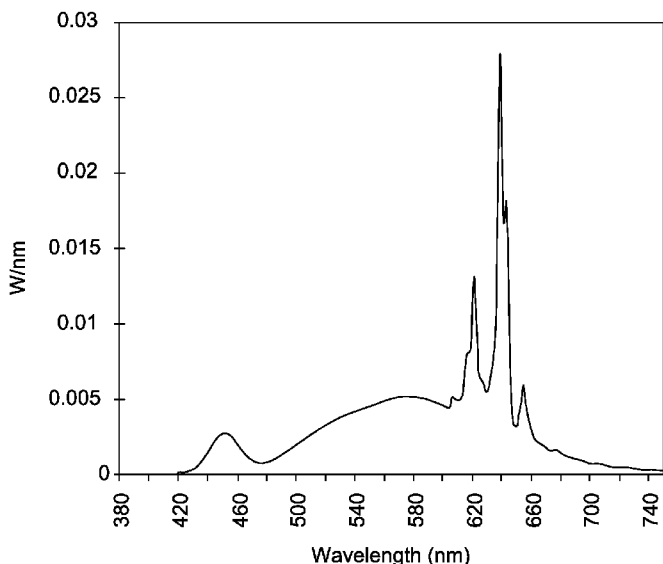

FIG. 6

(57) Abstract: A phosphor material is presented that includes a blend of a first phosphor, a second phosphor and a third phosphor. The first phosphor includes a composition having a general formula of ((Sr_{1-z}M_z)_{1-(x+w)}A_wCe_x)(Al_{1-y}Si_y)O_{4+y+3(x-w)}F_{1-y-3(x-w)}, wherein 0 < x ≤ 0.10, 0 ≤ y ≤ 0.5, 0 ≤ z ≤ 0.5, 0 ≤ w ≤ x, A comprises Li, Na, K, or Rb; and M comprises Ca, Ba, Mg, Zn, or Sn. The second phosphor includes a complex fluoride doped with manganese (Mn⁴⁺), and the third phosphor include a phosphor composition having an emission peak in a range from about 520 nanometers to about 680 nanometers. A lighting apparatus including such a phosphor material is also presented. The light apparatus includes a light source in addition to the phosphor material.

WO 2013/003166 A1

Declarations under Rule 4.17:

- *as to applicant's entitlement to apply for and be granted a patent (Rule 4.17(ii))*
- *as to the applicant's entitlement to claim the priority of the earlier application (Rule 4.17(iii))*

Published:

- *with international search report (Art. 21(3))*

PHOSPHOR MATERIALS AND RELATED DEVICES

CROSS REFERENCE TO RELATED APPLICATIONS

[0001] This application is a continuation in part of US Patent Application No. 12/256,142, entitled "BLUE_GREEN AND GREEN PHOSPHORS FOR LIGHTING APPLICATIONS" filed on October 22, 2008, which is herein incorporated by reference.

BACKGROUND

[0002] The invention relates generally to phosphor blends for wavelength conversion, and specifically phosphor blends for the conversion of radiation emitted by a light source. More particularly, the invention relates to phosphor blends for use with the blue light emitting diodes (LEDs).

[0003] A phosphor is a luminescent material that absorbs radiation energy in a portion of the electromagnetic spectrum and emits radiation energy in another portion of the electromagnetic spectrum. One important class of phosphors includes crystalline inorganic compounds of very high chemical purity and of controlled composition to which small quantities of other elements (called "activators") have been added to convert them into efficient fluorescent materials. With the right combination of activators and inorganic compounds, the color of the emission can be controlled. Most useful and well-known phosphors emit radiation (also referred to as light herein) in the visible portion of the electromagnetic spectrum in response to excitation by electromagnetic radiation outside the visible range. For example, the phosphors have been used in mercury vapor discharge lamps to convert the ultra-violet (UV) radiation emitted by the excited mercury to visible radiation. Further, the phosphors may be used in a light emitting diode (LED) to generate colored emissions that may generally not be obtained from the LED itself.

[0004] Light emitting diodes (LEDs) are semiconductor light emitters often used as a replacement for other light sources, such as incandescent lamps. They are

particularly useful as display lights, warning lights and indicating lights or in other applications where a colored light is desired. The color of light produced by an LED is dependent on the type of the semiconductor material used in its manufacture. The colored LEDs are often used in toys, indicator lights and other devices.

[0005] The colored semiconductor light emitting devices, including light emitting diodes and lasers (both are generally referred to as LEDs herein), have been produced from Group III-V alloys such as gallium nitride (GaN). With reference to the GaN-based LEDs, light is generally emitted in the UV and/or blue range of the electromagnetic spectrum. Until quite recently, the LEDs have not been suitable for lighting uses where a bright white light is needed, due to the inherent color of the light produced by the LEDs.

[0006] Techniques have been developed for converting the light emitted from the LEDs to useful light for illumination purposes. In one technique, the LED is coated or covered with a phosphor layer. The phosphor absorbs radiation generated by the LED, and generates radiation of a different wavelength, for example, in the visible range of the spectrum.

[0007] A combination of LED generated light and phosphor generated light may be used to produce white light. The most popular white LEDs are based on blue emitting GaInN chips. The blue emitting LEDs are coated with a phosphor or a phosphor blend including red, green and blue emitting phosphors that converts some of the blue radiation to a complementary color, for example a yellow-green emission. The total of the light from the phosphor and the LED chip provides white light having a color point with corresponding color coordinates (x and y) and correlated color temperature (CCT), and its spectral distribution provides a color rendering capability, measured by the color rendering index (CRI).

[0008] These white LEDs typically produces white light with a CRI between about 70 and about 80 for a tunable CCT greater than about 4000K. While such white LEDs are suitable for some applications, it is desirable to produce white light with

higher CRIs (greater than about 90) and lower CCT (less than 3000K) for many other applications.

[0009] Therefore, it would be desirable to provide new and improved phosphor blends that produce white light with high CRI and high lumen for low CCT.

BRIEF DESCRIPTION

[0010] Briefly, most of the embodiments of the present invention provide a phosphor material that includes a blend of a first phosphor, a second phosphor and a third phosphor. The first phosphor includes a composition having a general formula of $((\text{Sr}_{1-z}\text{M}_z)_{1-(x+w)}\text{A}_w\text{Ce}_x)_3(\text{Al}_{1-y}\text{Si}_y)\text{O}_{4+y+3(x-w)}\text{F}_{1-y-3(x-w)}$, wherein $0 < x \leq 0.10$, $0 \leq y \leq 0.5$, $0 \leq z \leq 0.5$, $0 \leq w \leq x$, A comprises Li, Na, K, or Rb; and M comprises Ca, Ba, Mg, Zn, or Sn. The second phosphor includes a complex fluoride doped with manganese (Mn^{4+}), and the third phosphor include a phosphor composition having an emission peak in a range from about 520 nanometers (nm) to about 680 nanometers (nm).

[0011] Some embodiments relate to a lighting apparatus. The lighting apparatus includes a light source; and a phosphor material radiationally coupled to the light source. The phosphor material includes a blend of a first phosphor, a second phosphor and a third phosphor. The first phosphor includes a composition having a general formula of $((\text{Sr}_{1-z}\text{M}_z)_{1-(x+w)}\text{A}_w\text{Ce}_x)_3(\text{Al}_{1-y}\text{Si}_y)\text{O}_{4+y+3(x-w)}\text{F}_{1-y-3(x-w)}$, wherein $0 < x \leq 0.10$, $0 \leq y \leq 0.5$, $0 \leq z \leq 0.5$, $0 \leq w \leq x$, A comprises Li, Na, K, or Rb; and M comprises Ca, Ba, Mg, Zn, or Sn. The second phosphor includes a complex fluoride doped with manganese (Mn^{4+}), and the third phosphor include a phosphor composition having an emission peak in a range from about 520 nm to about 680 nm.

DRAWINGS

[0012] These and other features, aspects, and advantages of the present invention will become better understood when the following detailed description is

read with reference to the accompanying drawings in which like characters represent like parts throughout the drawings, wherein:

[0013] FIG. 1 is a schematic cross sectional view of a lighting apparatus according to one embodiment of the invention;

[0014] FIG. 2 is a schematic cross sectional view of a lighting apparatus according to one embodiment of the invention;

[0015] FIG. 3 is a schematic cross sectional view of a lighting apparatus according to one embodiment of the invention;

[0016] FIG. 4 is a schematic cross sectional view of a lighting apparatus according to one embodiment of the invention;

[0017] FIG. 5 is a schematic cross sectional view of a lighting apparatus according to one embodiment of the invention;

[0018] FIG.6 shows the emission spectra of a phosphor blend using a 450 nm excitation wavelength, in accordance with an exemplary embodiment of the invention;

[0019] FIG.7 shows the emission spectra of a phosphor blend using a 450 nm excitation wavelength, in accordance with another exemplary embodiment of the invention;

[0020] FIG.8 shows the emission spectra of a phosphor blend using a 430 nm excitation wavelength, in accordance with an exemplary embodiment of the invention;

[0021] FIG.9 shows the emission spectra of a phosphor blend using a 430 nm excitation wavelength, in accordance with an exemplary embodiment of the invention.

DETAILED DESCRIPTION

[0022] Approximating language, as used herein throughout the specification and claims, may be applied to modify any quantitative representation that could permissibly vary without resulting in a change in the basic function to which it is related. Accordingly, a value modified by a term or terms, such as "about," is not limited to the precise value specified. In some instances, the approximating language may correspond to the precision of an instrument for measuring the value.

[0023] In the following specification and the claims that follow, the singular forms "a", "an" and "the" include plural referents unless the context clearly dictates otherwise.

[0024] As used herein, the terms "may" and "may be" indicate a possibility of an occurrence within a set of circumstances; a possession of a specified property, characteristic or function; and/or qualify another verb by expressing one or more of an ability, capability, or possibility associated with the qualified verb. Accordingly, usage of "may" and "may be" indicates that a modified term is apparently appropriate, capable, or suitable for an indicated capacity, function, or usage, while taking into account that in some circumstances the modified term may sometimes not be appropriate, capable, or suitable. For example, in some circumstances, an event or capacity can be expected, while in other circumstances the event or capacity cannot occur – this distinction is captured by the terms "may" and "may be".

[0025] As used herein, the term "phosphor" or "phosphor material" or "phosphor composition" may be used to denote both a single phosphor composition as well as a blend of two or more phosphor compositions. The phosphor blend may contain blue, red, yellow, orange and green phosphors. The blue, red, yellow, orange and green phosphors are so called or known after the color of their light emission.

[0026] As used herein, the terms "substitution" and "doping" refer to adding an amount of an element in a material. Typically, an element in a material is partially or fully replaced by another element on such addition. It should be noted that various phosphors described herein may be written down by enclosing different elements in

parentheses and separated by commas to show substitution or doping, such as in the case of $((\text{Ba,Ca,Sr})_{1-x}\text{Eu}_x)_2\text{Si}_5\text{N}_8$. As understood by those skilled in the art, this type of notation means that the phosphor can include any or all of those specified elements in the formulation in any ratio. That is, this type of notation for the above phosphor, for example, has the same meaning as $((\text{Ba}_a\text{Ca}_b\text{Sr}_{1-a-b})_{1-x}\text{Eu}_x)_2\text{Si}_5\text{N}_8$, where a and b can vary from 0 to 1, including the values of 0 and 1.

[0027] Particular application is described, herein, in conjunction with converting LED-generated ultraviolet (UV), violet, or blue radiation into white light for general illumination purposes. It should be appreciated, however, that the invention is also applicable to the conversion of radiation from UV, violet, and/or blue lasers, as well as other light sources, to white light.

[0028] Embodiments of the present techniques provide phosphor blends that may be used in lighting systems to generate white light suitable for general illumination and other purposes. The phosphor blends include systems having a first phosphor of general formula (I): $((\text{Sr}_{1-z}\text{M}_z)_{1-(x+w)}\text{A}_w\text{Ce}_x)_3(\text{Al}_{1-y}\text{Si}_y)\text{O}_{4+y+3(x-w)}\text{F}_{1-y-3(x-w)}$; wherein $0 < x \leq 0.10$ and $0 \leq y \leq 0.5$, $0 \leq z \leq 0.5$, $0 \leq w \leq x$; A may include Li, Na, K, Rb, or a combination thereof; and M may include Ca, Ba, Mg, Zn, or a combination thereof. Advantageously, the phosphors made according to these formulations may maintain an emission intensity (quantum efficiency) across a wide range of temperatures. The phosphors may be used in lighting systems, such as LEDs and fluorescent tubes, among others, to produce blue and blue/green light.

[0029] In general formula I, shown above, the addition of the Ce^{3+} and Si^{4+} ions is charge balanced, resulting in a zero charge system, by using both an addition of an alkali metal and a modification of the amount of oxide and fluoride ions in the formulation. However, if the addition of Ce^{3+} ions is charge balanced only by including an alkali metal A, the formula above reduces to a general formula (II): $((\text{Sr}_{1-y}\text{M}_y)_{1-2x}\text{A}_x\text{Ce}_x)_3\text{AlO}_4\text{F}$; wherein $0 < x \leq 0.10$, $0 \leq y \leq 0.5$; A may include Li, Na, K, Rb, or a combination thereof; and M may include Ca, Ba, Mg, Zn, or a combination thereof. If the addition of the Ce^{3+} ions is charge balanced by adjusting the amount of

oxide and fluoride ions in the formula, the resulting formula (III) is $((\text{Sr}_{1-z}\text{M}_z)_{1-x}\text{Ce}_x)_3(\text{Al}_{1-y}\text{Si}_y)\text{O}_{4+y+3x}\text{F}_{1-y-3x}$; wherein $0 < x \leq 0.10$ and $0 \leq y \leq 0.5$; $0 \leq z \leq 0.5$; and M may include Ca, Ba, Mg, Zn, or a combination thereof.

[0030] In any of the phosphors of general formulas I-III, a portion or all of the Al^{3+} may be substituted with other equivalently charged ions. For example, Al^{3+} may be partially or totally substituted with B^{3+} , Ga^{3+} , Sc^{3+} , or Y^{3+} , among others, or a combination thereof. This may allow for tuning the spectrum obtained from the phosphors.

[0031] Furthermore, the first phosphor may be additionally doped with an additional activator ion. As used herein, the term “activator ion” refers to an ion (for example Ce^{3+}) doped in a phosphor that forms luminescent center and is responsible for the luminescence of the phosphor. Such ions may include ions of Pr, Sm, Eu, Tb, Dy, Tm, Er, Ho, Nd, Bi, Yb, Pb, Yb, Mn, Ag, Cu, or any combinations thereof.

[0032] The phosphors of general formulas I-III of the present techniques have the advantage of a reduced quenching of the luminescence at high temperatures, for example, having a quantum efficiency at about 150° C that is at least about 80% of the quantum efficiency measured at ambient temperature, such as between about 15° C and about 25° C. In contrast, many current phosphors have a quantum efficiency at 150° C that is only about 60% of the quantum efficiency at ambient temperature. Accordingly, these phosphors maintain their emission intensity across a large range of temperatures, which may mitigate losses of intensity or lamp color shifts as the temperature of a lighting system increases during use.

[0033] The phosphor blends, further include systems of a second phosphor that is a red line emitter and a third phosphor that has a peak emission in a broad wavelength range from about 520 nm to about 680 nm. The second phosphor may be a complex fluoride that is a line emitter and generates red light. Suitable examples include complex fluorides doped with Mn^{4+} , for example $(\text{Na}, \text{K}, \text{Rb}, \text{Cs}, \text{NH}_4)_2[(\text{Ti}, \text{Ge}, \text{Sn}, \text{Si}, \text{Zr}, \text{Hf})\text{F}_6]:\text{Mn}^{4+}$ and the like. In certain instances, a complex fluoride

doped with Mn^{4+} is $\text{K}_2[\text{SiF}_6]:\text{Mn}^{4+}$ (“PFS”) used in some illustrative blend examples further below.

[0034] The third phosphor may include a phosphor composition having an emission peak in a range from about 520 nanometers (nm) to about 680 nm. The third phosphor is usually a yellow or a yellow-orange phosphor having broad emission range. Non-limiting examples of suitable third phosphors may include a garnet, a nitride, and an oxynitride. Table 1 shows some of such examples. Any combination having two or more members selected from the group consisting of a garnet, a nitride, and an oxynitride may also be used.

[0035] In some embodiments, the third phosphor may be a garnet of general formula $(\text{A}, \text{Ce})_3\text{M}_{5-a}\text{O}_{12-3/2a}$, wherein $0 \leq a \leq 0.5$, A comprises Y, Gd, Tb, La, Sm, Pr, or Lu, and M comprises Sc, Al, or Ga. An example of such garnet is $\text{Y}_3\text{Al}_5\text{O}_{12}:\text{Ce}^{3+}$ (YAG). This garnet YAG has an emission peak in a broad wavelength range from about 525 nm to about 645 nm.

[0036] In some embodiments, the third phosphor may be a nitride of general formula $(\text{A}, \text{Eu})_x\text{Si}_y\text{N}_z$, wherein $2x+3y=4z$, and A comprises Ba, Ca, Sr, or a combination thereof. The nitride may be further doped with cerium. Some embodiments include $\text{A}_2\text{Si}_5\text{N}_8:\text{Eu}^{2+}$, wherein A comprises Ba, Ca, or Sr. In certain instances, the nitride is of formula $((\text{Ba}, \text{Ca}, \text{Sr})_{1-a-b}\text{Eu}_a\text{Ce}_b)_2\text{Si}_5\text{N}_8$, where $0 \leq a \leq 1$ and $0 \leq b \leq 1$. These nitrides emit in broad wavelength range from about 575 nm to about 675 nm.

[0037] In some embodiments, the third phosphor may be an oxynitride phosphor of general formula $\text{A}_p\text{B}_q\text{O}_r\text{N}_s:\text{R}$, where A comprises barium, B comprises silicon, and R comprises europium; and $2 < p < 6$, $8 < q < 10$, $0.1 < r < 6$, $10 < s < 15$. In these instances, A may further comprises strontium, calcium, magnesium, or a combination thereof; B may further comprise aluminum, gallium, germanium, or a combination thereof; and R may further comprise cerium. In certain instances, the oxynitride phosphor is of formula $(\text{Ba}, \text{Ca}, \text{Sr}, \text{Mg})_4\text{Si}_9\text{O}_r\text{N}_{14.66 - (2/3)r}:\text{Eu}$ such that r is

greater than about 1 and less than or equal to about 4. The emission peak of these oxynitrides exit in wavelength range from about 545 nm to about 645nm.

TABLE 1

Formulas of the third phosphor used in the phosphor blend	
Name	Formula
Garnet	$Y_3Al_5O_{12}:Ce^{3+}$
Nitride	$((Ba, Ca, Sr)_{1-a-b}Eu_aCe_b)_2Si_5N_8$; where $0 \leq a \leq 1$ and $0 \leq b \leq 1$
Oxynitride.....	$(Ba, Ca, Sr, Mg)_4Si_9O_rN_{14.66 - (2/3)r}$; where $1 < r < 4$

[0038] Each of the general formulas listed herein is independent of every other general formula listed. Specifically, x, y, z, and other variables that may be used as numeric placeholders in a formula are not related to any usage of x, y, z and other variables that may be found in other formulas or compositions.

[0039] When the phosphor material includes a blend of two or more phosphors, the ratio of each of the individual phosphors in the phosphor blend may vary, depending on the characteristics of the desired light output, for example color temperature. The relative amounts of each phosphor in the phosphor blend can be described in terms of spectral weight. The spectral weight is the relative amount that each phosphor contributes to the overall emission spectrum of the device. The spectral weight amounts of all the individual phosphors and any residual bleed from the LED source should add up to 100%. In a preferred embodiment, each of the above described phosphors in the blend will have a spectral weight ranging from about 1 percent to about 70percent.

[0040] The relative proportions of each phosphor in the phosphor blends may be adjusted, so that when their emissions are blended and employed in a lighting device, there is produced visible light of predetermined ccx and ccy values on the CIE (International Commission on Illumination) chromaticity diagram. As stated, a white light is preferably produced. This white light may, for instance, possess a ccx value in the range of about 0.25 to about 0.55, and a ccy value in the range of about 0.25 to about 0.55.

[0041] The phosphors used to make phosphor blends, may be produced by mixing powders of the constituent compounds and then firing the mixture under a reducing atmosphere. Typically, oxygen-containing compounds of the relevant metals are used. A fluoride species may be further used for the first phosphor. For example, the illustrative phosphor $(\text{Sr}_{0.98}\text{Na}_{0.01}\text{Ce}_{0.01})(\text{Al}_{0.9}\text{Si}_{0.1})\text{O}_{4.1}\text{F}_{0.9}$, discussed further in the examples below, may be produced by mixing the appropriate amounts of oxygen-containing compounds of strontium, calcium, sodium, cerium, aluminum, and silicon with the appropriate amount of a fluoride containing compound, and then firing the mixture under a reducing atmosphere. After firing, the phosphor may be ball milled, or otherwise ground, to break up any conglomerates that may have formed during the firing procedure. The grinding may be performed after all firing steps are completed, or may be interspersed with additional firing steps.

[0042] Non-limiting examples of suitable oxygen-containing compounds include oxides, hydroxides, alkoxides, carbonates, nitrates, aluminates, silicates, citrates, oxalates, carboxylates, tartarates, stearates, nitrites, peroxides and combinations of these compounds. In embodiments containing carboxylates, the carboxylates used may generally have from one to five carbon atoms, such as formates, ethanoates, propanoates, butyrates, and pentanoates, although carboxylates having larger numbers of carbon atoms may be used.

[0043] The mixture of the constituent compounds for producing the phosphor may also comprise a flux, such as boric acid, lithium tetraborate, an alkali carbonate, an alkali phosphate, or a mixture of these compounds. Fluoride and other halide compounds may also perform as a flux. The flux may aid in the phase formation of the intended phosphor and may also lower the firing temperature and/or time for the phosphor. If a flux is used, it may be desirable to wash the final phosphor product with a suitable solvent to remove any residual soluble impurities that may have originated from the flux.

[0044] The constituent compounds may be mixed together by any mechanical method. Such methods may include stirring or blending the powders in a high speed blender or a ribbon blender, or combining and pulverizing the powders in a ball mill,

hammer mill, or jet mill. Any number of other techniques may also be suitable for making a well-blended mixture of powders. If the mixture is wet, it may be dried first before being fired. The drying may be carried out at ambient atmosphere or under a vacuum.

[0045] Further, the first phosphors, the second phosphors and the third phosphors discussed above may be blended into solid solutions to form a phosphor blend. One method could be by making each of the individual phosphors, and then firing a raw blend of the three, or more, phosphors together. For example, phosphor blends may be made that contain solid solutions of the first phosphor having the general formula I, the second phosphor having the general formula $K_2[SiF_6]:Mn^{4+}$, and the third phosphor of general formula $Y_3Al_5O_{12}:Ce^{3+}$ (YAG). Any of the activator ions discussed above may be used in these phosphors to obtain the desired emission spectrum.

[0046] In addition to the synthesis procedures discussed above, many of the phosphors that may be used in the blends described herein may be commercially available. For example, the phosphor YAG, used in blend calculations in presently disclosed phosphor blends, may be commercially available.

[0047] The phosphors listed above are not intended to be limiting. Any other phosphors, commercial and non-commercial, that form non-reactive blends with the phosphors of the present techniques may be used in blends and are to be considered to be within the scope of the present techniques. Furthermore, some additional phosphors may be used, e.g., those emitting throughout the visible spectrum region, at wavelengths substantially different from those of the phosphors described herein. These additional phosphors may be used in the blend to customize the white color of the resulting light, and to produce sources with improved light quality.

[0048] One embodiment of the invention is directed to a lighting apparatus that includes a phosphor blend radiationally coupled to a light source. As used herein, the term "radiationally coupled" means that the elements are associated with each other so that at least part of the radiation emitted from one is transmitted to the other.

A combination of the light from the light source and the light from the phosphor blend may be used to produce white light. For example, a white LED may be based on a blue emitting InGaN chip. The blue emitting chip may be coated with the phosphor blend to convert some of the blue radiation to a complementary color, e.g. a yellow-green emission.

[0049] Non-limiting examples of lighting apparatus or devices include devices for excitation by light-emitting diodes (LEDs), fluorescent lamps, cathode ray tubes, plasma display devices, liquid crystal displays (LCD's), UV excitation devices, such as in chromatic lamps, lamps for backlighting liquid crystal systems, plasma screens, xenon excitation lamps, and UV excitation marking systems. These uses are meant to be merely exemplary and not exhaustive.

[0050] The light emitted from the lighting apparatus may be characterized using any number of standard measurements. This characterization may normalize the data and make the comparison of light emitted by different lighting apparatus easier to determine. For example, the total of the light from a phosphor and from an LED chip provides a color point with corresponding color coordinates (x and y) in the CIE 1931 chromaticity diagram and correlated color temperature (CCT), and its spectral distribution provides a color rendering capability, measured by the color rendering index (CRI). The CRI is commonly defined as a mean value for 8 standard color samples (R1-8), usually referred to as the general Color Rendering Index, or Ra. A higher value for CRI produces a more "natural" appearance for illuminated objects. By definition, an incandescent light has a CRI of 100, while a typical compact fluorescent light may have a CRI of about 82. Further, the luminosity, or apparent brightness, of a source may also be determined from the spectrum of the emitted light. The luminosity is measured as lumens/W-opt, which represents the number of lumens that 1 watt of light having a particular spectral distribution would represent. A higher lumens/W-opt value indicates that a particular source would appear brighter to an observer.

[0051] As the light emitted from combined lighting apparatus components is generally additive, the final spectra of phosphor blends and/or lighting apparatus may

be predicted. For example, the amount of light emitted from each phosphor in a blend may be proportional to the amount of that phosphor within the blend. Accordingly, the emission spectrum resulting from the blend can be modeled, and the spectral properties, e.g., the CCT, the CRI, color axes (x and y), and lm/W-opt may be calculated from the predicted emission spectrum. Various blends that may be made using the phosphors described above are discussed in the examples below.

[0052] Referring to the figures now, FIG. 1 illustrates an exemplary LED based lighting apparatus or lamp 10 that may incorporate the phosphor blends of the present techniques. The LED based lighting apparatus 10 includes a semiconductor UV or visible light source, such as a light emitting diode (LED) chip 12. Power leads 14 that are electrically attached to the LED chip 12 provide the current that causes the LED chip 12 to emit radiation. The leads 14 may include thin wires supported on thicker package leads 16 or the leads may comprise self-supported electrodes and the package lead may be omitted. The leads 14 provide current to the LED chip 12 and thus cause the LED chip 12 to emit radiation.

[0053] The lamp 10 may include any semiconductor blue or UV light source that is capable of producing white light when its emitted radiation is directed onto the phosphor. In one embodiment, the semiconductor light source comprises a blue emitting LED doped with various impurities. Thus, the LED 12 may comprise a semiconductor diode based on any suitable III-V, II-VI or IV-IV semiconductor layers and having an emission wavelength of about 380 to 550 nm. In particular, the LED may contain at least one semiconductor layer comprising GaN, ZnSe or SiC. For example, the LED may comprise a nitride compound semiconductor represented by the formula $\text{In}_i\text{Ga}_j\text{Al}_k\text{N}$ (where $0 \leq i$; $0 \leq j$; $0 \leq k$ and $i + j + k = 1$) having an emission wavelength greater than about 380 nm and less than about 550 nm. Preferably, the chip is a near-UV or blue emitting LED having a peak emission wavelength from about 400 to about 500 nm. Such LED semiconductors are known in the art. The light source as described herein is an LED for convenience. However, as used herein, the term is meant to encompass all semiconductor light sources including, e.g., semiconductor laser diodes.

[0054] In addition to inorganic semiconductors, the LED chip 12 may be replaced by an organic light emissive structure or other light sources. Other types of light sources may be used in place of LEDs, such as the gas discharge device discussed with respect to FIG. 5, below. Examples of gas discharge devices include low-, medium-, and high-pressure mercury gas discharge lamps.

[0055] The LED chip 12 may be encapsulated within a shell 18, which encloses the LED chip and an encapsulant material 20 (also, referred to as "encapsulant"). The shell 18 may be glass or plastic. The encapsulant 20 may be an epoxy, plastic, low temperature glass, polymer, thermoplastic, thermoset material, resin, silicone, silicone epoxy, or any other type of LED encapsulating material. Further, the encapsulant 20 may be a spin-on glass or some other high index of refraction material. Typically, the encapsulant material 20 is an epoxy or a polymer material, such as silicone. The shell 18 and the encapsulant 20 are transparent, that is substantially optically transmissive, with respect to the wavelength of light produced by the LED chip 12 and a phosphor material 22, such as the phosphor blends of the present techniques. However, if the LED chip 12 emits light that is within the UV spectrum, the encapsulant 20 may only be transparent to light from the phosphor material 22. The LED based lighting apparatus 10 may include an encapsulant 20 without an outer shell 18. In this application, the LED chip 12 may be supported by the package leads 16, or by a pedestal (not shown) mounted to the package leads 16.

[0056] The phosphor material 22 is radiationally coupled to the LED chip 12. In one embodiment, the phosphor material 22 may be deposited on the LED chip 12 by any appropriate method. For example, a solvent based suspension of phosphors can be formed, and applied as a layer onto the surface of the LED chip 12. In a contemplated embodiment, a silicone slurry in which the phosphor particles are randomly suspended may be placed over the LED chip 12. Thus, the phosphor material 22 may be coated over or directly on the light emitting surface of the LED chip 12 by coating and drying the phosphor suspension over the LED chip 12. As the shell 18 and the encapsulant 20 will generally be transparent, an emitted light 24 from the LED chip 12 and the phosphor material 22 will be transmitted through those elements. Although not intended to be limiting, in one embodiment, the median

particle size of the phosphor material 22 as measured by light scattering may be from about 1 to about 15 microns.

[0057] A second structure that may incorporate the phosphor blends of the present techniques is illustrated in the cross section of FIG. 2. The structure in FIG. 2 is similar to that of FIG. 1, except that the phosphor material 22 is interspersed within the encapsulant 20, instead of being formed directly on the LED chip 12. The phosphor material 22 may be interspersed within a single region of the encapsulant 20 or throughout the entire volume of the encapsulant 20. Radiation 26 emitted by the LED chip 12 mixes with the light emitted by the phosphor material 22, and the mixed light may be visible through the transparent encapsulant 20, appearing as emitted light 24.

[0058] The encapsulant 20 with the interspersed phosphor material 22 may be formed by any number of suitable plastics processing techniques. For example, the phosphor material 22 may be combined with a polymer precursor, molded around the LED chip 12, and then cured to form the solid encapsulant 20 with the interspersed phosphor material 22. In another technique, the phosphor material 22 may be blended into a molten encapsulant 20, such as a polycarbonate, formed around the LED chip 12, and allowed to cool. Processing techniques for molding plastics that may be used, such as injection molding, are known in the art.

[0059] FIG. 3 illustrates a cross section of a structure that may incorporate the phosphor material 22 of the present techniques. The structure shown in FIG. 3 is similar to that of FIG. 1, except that the phosphor material 22 may be coated onto a surface of the shell 18, instead of being formed over the LED chip 12. Generally, the phosphor material 22 is coated on the inside surface of the shell 18, although the phosphor material 22 may be coated on the outside surface of the shell 18, if desired. The phosphor material 22 may be coated on the entire surface of the shell 18 or only a top portion of the surface of the shell 18. The radiation 26 emitted by the LED chip 12 mixes with the light emitted by the phosphor material 22, and the mixed light appears as emitted light 24.

[0060] The structures discussed with respect to FIGS. 1-3 may be combined, with the phosphor material located in any two or all three locations or in any other suitable location, such as separately from the shell or integrated into the LED. Further, different phosphor blends may be used in different parts of the structure.

[0061] In any of the above structures, the LED based lighting apparatus 10 may also include a plurality of particles (not shown) to scatter or diffuse the emitted light. These scattering particles would generally be embedded in the encapsulant 20. The scattering particles may include, for example, particles made from Al_2O_3 (alumina) or TiO_2 . The scattering particles may effectively scatter the light emitted from the LED chip 12, and are generally selected to have a negligible amount of absorption.

[0062] In addition to the structures above, the LED chip 12 may be mounted in a reflective cup 28, as illustrated by the cross section shown in FIG. 4. The reflective cup 28 may be made from or coated with a reflective material, such as alumina, titania, or other dielectric powder known in the art. Generally, the reflective surface may be made from Al_2O_3 . The remainder of the structure of the LED based lighting apparatus 10 of FIG. 4 is the same as that of the previous figure, and includes two leads 16, a conducting wire 30 electrically connecting the LED chip 12 with one of the leads 16, and an encapsulant 20. The reflective cup 28 may conduct current to energize the LED chip 12, or a second conducting wire 32 may be used for the same. The phosphor material 22 may be dispersed throughout the encapsulant 20, as described above, or may be dispersed in a smaller transparent casing 34 formed within the reflective cup 28. Generally, the transparent casing 34 may be made from the same materials as the encapsulant 20. The use of the transparent casing 34 within the encapsulant 20 may be advantageous in that a smaller amount of the phosphor material 22 may be required than if the phosphor were to be dispersed throughout the encapsulant 20. The encapsulant 20 may contain particles (not shown) of a light scattering material, as previously described to diffuse the emitted light 24.

[0063] FIG. 5 is a perspective view of a lighting apparatus 36 based on a gas discharge device, such as a fluorescent lamp, which may use the phosphor blends of

the present techniques. The lamp 36 may include an evacuated sealed housing 38, an excitation system 42 for generating UV radiation and located within the housing 38, and a phosphor material 22 disposed within the housing 38. End caps 40 are attached to either end of the housing 38 to seal the housing 38.

[0064] In a typical fluorescent lamp, the phosphor material 22, such as the phosphor blends of the present techniques, may be disposed on an inner surface of the housing 38. The excitation system 42 for generating the UV radiation may include an electron generator 44 for generating high-energy electrons and a fill gas 46 configured to absorb the energy of the high-energy electrons and emit UV light. For example, the fill gas 46 may include mercury vapor, which absorbs energy of the high-energy electrons and emits UV light. In addition to mercury vapor, the fill gas 46 may include a noble gas such as argon, krypton, and the like. The electron generator 44 may be a filament of a metal having a low work function (for example, less than 4.5 eV), such as tungsten, or a filament coated with alkaline earth metal oxides. Pins 48 may be provided to supply electrical power to the electron generator 44. The filament is coupled to a high-voltage source to generate electrons from the surface thereof.

[0065] The phosphor material 22 is radiationally coupled to the UV light from the excitation system 42. As previously described, radiationally coupled means that the phosphor material 22 is associated with the excitation system 42 so that radiation from the UV light from the excitation system 42 is transmitted to the phosphor material 22. Thus, a phosphor material that is radiationally coupled to the excitation system 42 may absorb radiation, such as the UV light emitted by the excitation system 42, and, in response, emit longer wavelengths, such as blue, blue-green, green, yellow, or red light. The longer wavelength of light may be visible as emitted light 24 transmitted through the housing 38. The housing 38 is generally made of a transparent material such as glass or quartz. Glass is commonly used as the housing 38 in fluorescent lamps, as the transmission spectrum of the glass may block a substantial portion of the “short wave” UV radiation, i.e., light having a wavelength of less than about 300 nm.

[0066] A particulate material, such as TiO_2 or Al_2O_3 , may be used in conjunction with the phosphor blend 22 to diffuse light generated by the light source 36. Such a light scattering material may be included with the phosphor blend 22 or separately disposed as a layer between the inner surface of the housing 38 and the phosphor blend 22. For a fluorescent tube, it may be advantageous to have the median size of the particles of the scattering material range from about 10 nm to about 400 nm.

[0067] Although the lighting apparatus or the lamp 36 shown in FIG. 5 has a straight housing 38, other housing shapes may be used. For example, a compact fluorescent lamp may have a housing 38 that has one or more bends or is in a spiral shape, with electrical supply pins 48 that are disposed at one end of the lamp 36.

[0068] By assigning appropriate spectral weights for each phosphor, one can create spectral blends to cover the relevant portions of color space for white lamps. Specific examples of this are shown below. For various desired CCT's, CRI's and color points, one can determine the appropriate amounts of each phosphor to include in the blend. Thus, one can customize phosphor blends to produce almost any CCT or color point, with corresponding high CRI. Of course, the color of each phosphor will be dependent upon its exact composition (for example relative amounts of Ba, Ca, Sr, as well as Eu in nitride phosphor), which can change the color of the phosphor to a degree where it may have to be renamed. However, determining the changes in the spectral weight to produce the same or similar characteristic lighting device necessitated by such variations is trivial and can be accomplished by one skilled in the art using various methodologies, such as design of experiment (DOE) or other strategies.

[0069] By use of the present invention, particularly the blends described in herein, lamps can be provided having high luminosity and general CRI values greater than about 80, for a low range of color temperatures of interest (2500 K to 4000 K) for general illumination. In some blends, the CRI values approach the theoretical maximum of 100. In addition, the R_9 value for these blends can exceed about 90 and approach the theoretical maximum as well. Table 1 and Table 2 show luminosity,

CRI values and R₉ values of various blends at CCT values 2700K and 3000K, respectively.

EXAMPLES

[0070] The examples that follow are merely illustrative, and should not be construed to be any sort of limitation on the scope of the claimed invention.

[0071] The techniques described above were used to synthesize the individual phosphors listed in Table 2. The emission spectra of individual phosphors listed in Table 2 were obtained, and used in calculations to predict emission spectra for various blends presented in Table 3. Further, the calculations also included any visible light emitted by a light source. FIGS. 6-9 show the predicted emission spectra of the examples 1-5 of the blends in Table 3. The predicted amount of each phosphor based on spectral weight is shown in the Tables 4 and 5 along with the spectral contribution of the emissions from the light sources, for example blue LEDs having peak wavelengths of 430 nm, 440 nm and 450 nm. Further, the spectral characteristics calculated from the predicted spectra for these blends are also presented in Table 4 and Table 5. FIGS. 6, 7, and 8 correspond to the blend examples No.13, No. 16, and No. 17 of Table 5, and FIG. 9 corresponds to the blend example No. 3 of Table 4. Advantageously, these blends generate white light having high luminosity, a high CRI value and a low CCT that can be tuned between 2500K and 3000K.

TABLE 2

Formulas of example phosphors used in the phosphor blend	
Name	Formula
SASOF-10	$(\text{Sr}_{0.98}\text{Na}_{0.01}\text{Ce}_{0.01})_3(\text{Al}_{0.9}\text{Si}_{0.1})\text{O}_{4.1}\text{F}_{0.9}$
SASOF-40	$(\text{Sr}_{0.595}\text{Ca}_{0.4}\text{Ce}_{0.005})_3(\text{Al}_{0.6}\text{Si}_{0.4})\text{O}_{4.415}\text{F}_{0.585}$
PFS	$\text{K}_2[\text{SiF}_6]:\text{Mn}^{4+}$
YAG	$\text{Y}_3\text{Al}_5\text{O}_{12}:\text{Ce}^{3+}$
C-BASIN	$(\text{Ba}_{0.78}, \text{Ca}_{0.52}\text{Eu}_{0.06}\text{Ce}_{0.01})_2\text{Si}_5\text{N}_8$
YON	$\text{Ba}_4\text{Si}_9\text{O}_4\text{N}_{12}:\text{Eu}^{2+}$

TABLE 3

Examples of phosphor blends produced	
Example.	Phosphor blend
Example 1	SASOF-10/YAG/PFS
Example 2	SASOF-40/YAG/PFS
Example 3	SASOF-10/YON/PFS
Example 4	SASOF-40/YON/PFS
Example 5	SASOF-10/CBASIN/PFS

[0072] While only certain features of the invention have been illustrated and described herein, many modifications and changes will occur to those skilled in the art. It is, therefore, to be understood that the appended claims are intended to cover all such modifications and changes as fall within the true spirit of the invention.

TABLE 4

S. No .	CCT	LED emission (nm)	Spectral weight of LED emission	Spectral weight of YAG	Spectral weight of PFS	Spectral weight of SASOF-10	Spectral weight of SASOF-40	Lumensosity (lumen/watt)	CRI	R9
1	2700K	430	0.095	0.443	0.293	0.168		320	86	90.2
2		440	0.077	0.479	0.294	0.148		327	87.9	92
3		450	0.0756	0.515	0.291	0.117		330	90.1	93.9
4		430	0.099	0.461	0.294		0.05	320	85.9	90.9
5		440	0.0805	0.49	0.297		0.049	328	87.6	92.5
6		450	0.0809	0.325	0.291		0.3	329	90.1	94.3
7	3000K	430	0.116	0.359	0.26	0.263		319	85.4	88.1
8		440	0.095	0.398	0.262	0.243		328	87.3	90.3
9		450	0.09	0.439	0.259	0.208		331	90.2	92
10		450		0.081	0.26		0.5616	332	90.2	93.3

TABLE 5

S.No.	CCT	LED emission (nm)	Spectral weight of LED emission	Spectral weight of PFS	Spectral weight of YON	Spectral weight of C-BASIN	Spectral weight of SASOF-10	Spectral weight of SASOF-40	Lumensosity (lumen/watt)	CRI	R9
11	2700K	430	0.0839	0.276	0.207		0.432		322	91.2	97.3
12		440	0.067	0.280	0.217		0.434		328	92.8	97.4
13		450	0.0646	0.277	0.231		0.425		330	95.1	96.6
14	3000K	430	0.108	0.243	0.166		0.481		320	89.3	97.7
15		440	0.087	0.248	0.177		0.486		329	91.3	98.1
16		450	0.085	0.246	0.193		0.474		330	94.3	98.2
17		450	0.07	0.07		0.42	0.43		293	97	93
18		450	0.1	0.2		0.1		0.6	324	91	96

CLAIMS:

1. A phosphor material comprising a blend of:

a first phosphor comprising a composition having a general formula of $((\text{Sr}_{1-z}\text{M}_z)_{1-(x+w)}\text{A}_w\text{Ce}_x)_3(\text{Al}_{1-y}\text{Si}_y)\text{O}_{4+y+3(x-w)}\text{F}_{1-y-3(x-w)}$, wherein $0 < x \leq 0.10$, $0 \leq y \leq 0.5$, $0 \leq z \leq 0.5$, $0 \leq w \leq x$, A comprises Li, Na, K, or Rb; and M comprises Ca, Ba, Mg, Zn, or Sn;

a second phosphor comprising a complex fluoride doped with manganese (Mn^{4+}), and

a third phosphor comprising a phosphor composition having an emission peak in a range from about 520 nanometers to about 680 nanometers.

2. The phosphor material of claim 1, wherein at least a portion of Al in the first phosphor is substituted by B, Ga, Sc, or Y.

3. The phosphor material of claim 1, wherein at least a portion of F in the first phosphor is substituted by Cl, Br, or I.

4. The phosphor material of claim 1, wherein the first phosphor is doped with an additional activator ion.

5. The phosphor material of claim 4, wherein the additional activator ion comprises Pr, Sm, Eu, Tb, Dy, Tm, Er, Ho, Nd, Bi, Pb, Yb, Mn, Ag, or Cu.

6. The phosphor material of claim 1, wherein the first phosphor comprises a general formula of $((\text{Sr}_{1-z}\text{M}_z)_{1-2x}\text{A}_x\text{Ce}_x)_3\text{AlO}_4\text{F}$, wherein $0 < x \leq 0.10$, $0 \leq z \leq 0.5$, A comprises Li, Na, K, or Rb; and M comprises Ca, Ba, Mg, Zn, or Sn.

7. The phosphor material of claim 1, wherein the first phosphor comprises a general formula of $((\text{Sr}_{1-z}\text{M}_z)_{1-x}\text{Ce}_x)_3(\text{Al}_{1-y}\text{Si}_y)\text{O}_{4+y+3x}\text{F}_{1-y-3x}$, wherein $0 < x \leq 0.10$, $0 \leq y \leq 0.5$, $0 \leq z \leq 0.5$, and M comprises Ca, Ba, Mg, Zn, or Sn.

8. The phosphor material of claim 1, wherein the first phosphor comprises $(\text{Sr}_{0.98}\text{Na}_{0.01}\text{Ce}_{0.01})_3\text{AlO}_4\text{F}$, $(\text{Sr}_{0.98}\text{Na}_{0.01}\text{Ce}_{0.01})_3(\text{Al}_{0.9}\text{Si}_{0.1})\text{O}_{4.1}\text{F}_{0.9}$, $(\text{Sr}_{0.98}\text{Na}_{0.01}\text{Ce}_{0.01})_3(\text{Al}_{0.8}\text{Si}_{0.2})\text{O}_{4.2}\text{F}_{0.8}$, $(\text{Sr}_{0.98}\text{Ca}_{0.23}\text{Na}_{0.01}\text{Ce}_{0.01})_3(\text{Al}_{0.75}\text{Si}_{0.25})\text{O}_{4.25}\text{F}_{0.75}$, or $(\text{Sr}_{0.595}\text{Ca}_{0.4}\text{Ce}_{0.005})_3(\text{Al}_{0.6}\text{Si}_{0.4})\text{O}_{4.415}\text{F}_{0.585}$.

9. The phosphor material of claim 1, wherein the second phosphor comprises a general formula $\text{A}_2[\text{MF}_6]:\text{Mn}^{4+}$, wherein A comprises Na, K, Rb, Cs, or NH_4 ; and M comprises Si, Ti, Zr, or Mn.

10. The phosphor material of claim 1, wherein the second phosphor comprises $\text{K}_2[\text{SiF}_6]:\text{Mn}^{4+}$, or $\text{K}_2[\text{TiF}_6]:\text{Mn}^{4+}$.

11. The phosphor material of claim 1, wherein the third phosphor comprises a garnet, a nitride, or an oxynitride.

12. The phosphor material of claim 11, wherein the third phosphor comprises a garnet of general formula $(A, Ce)_3M_{5-a}O_{12-3/2a}$, wherein $0 \leq a \leq 0.5$, A comprises Y, Gd, Tb, La, Sm, Pr, or Lu; and M comprises Sc, Al, or Ga.

13. The phosphor material of claim 12, wherein the third phosphor comprises $Y_3Al_5O_{12}:Ce^{3+}$.

14. The phosphor material of claim 11, wherein the third phosphor comprises a nitride of general formula $(A, Eu)_xSi_yN_z$, wherein $2x+3y=4z$, and A comprises Ba, Ca, or Sr.

15. The phosphor material of claim 14, wherein the third phosphor comprises $A_2Si_5N_8:Eu^{2+}$, wherein A comprises Ba, Ca, or Sr.

16. The phosphor material of claim 14, wherein the nitride is further doped with cerium.

17. The phosphor material of claim 11, wherein the third phosphor comprises an oxynitride of a general formula $A_pB_qO_rN_s$; R, where A comprises barium, B comprises silicon, and R comprises europium; and $2 < p < 6$, $8 < q < 10$, $0.1 < r < 6$, $10 < s < 15$.

18. The phosphor material of claim 17, wherein the third phosphor comprises $(Ba, Ca, Sr, Mg)_4Si_9O_rN_{14.66-(2/3)r}$; Eu; where $1 < r < 4$.

19. The phosphor material of claim 1, wherein the first phosphor is present in a spectral weight from about 1 percent to about 70 percent, the second phosphor is present in a spectral weight from about 1 percent to about 70 percent, and the third phosphor is present in a spectral weight from about 1 percent to about 70 percent.

20. A lighting apparatus comprising: a light source capable of emitting radiation in a range from about 400 nanometers to about 480 nanometers; and a phosphor material radiationally coupled to the light source, the phosphor material comprising a blend of:

a first phosphor comprising a composition having a general formula of $((\text{Sr}_{1-z}\text{M}_z)_{1-(x+w)}\text{A}_w\text{Ce}_x)_3(\text{Al}_{1-y}\text{Si}_y)\text{O}_{4+y+3(x-w)}\text{F}_{1-y-3(x-w)}$, wherein $0 < x \leq 0.10$, $0 \leq y \leq 0.5$, $0 \leq z \leq 0.5$, $0 \leq w \leq x$, A is Li, Na, K, or Rb; and M is Ca, Ba, Mg, Zn, or Sn.

a second phosphor comprising a complex fluoride doped with manganese (Mn^{4+}), and

a third phosphor comprising a phosphor composition having an emission peak in a range from about 520 nanometers to about 680 nanometers.

21. The lighting apparatus of claim 20, wherein the light source comprises a light emitting device (LED).

22. The lighting apparatus of claim 20, further comprising an encapsulant surrounding the light source.

23. The lighting apparatus of claim 20, wherein the phosphor material is coated on a surface of the light source.

24. The lighting apparatus of claim 22, wherein the phosphor material is dispersed in the encapsulant.

25. The lighting apparatus of claim 20, has a CRI (Rg) greater than 80 and R9 greater than 50.

1/5

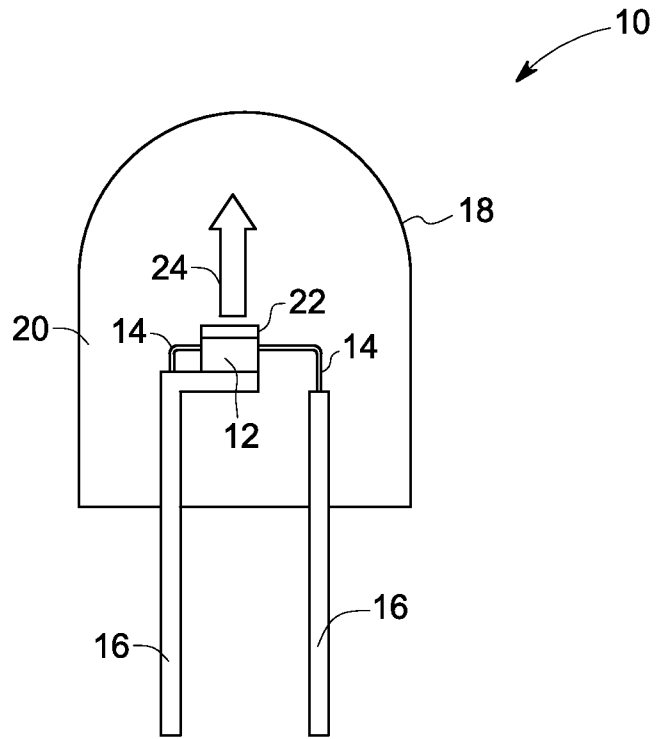

FIG. 1

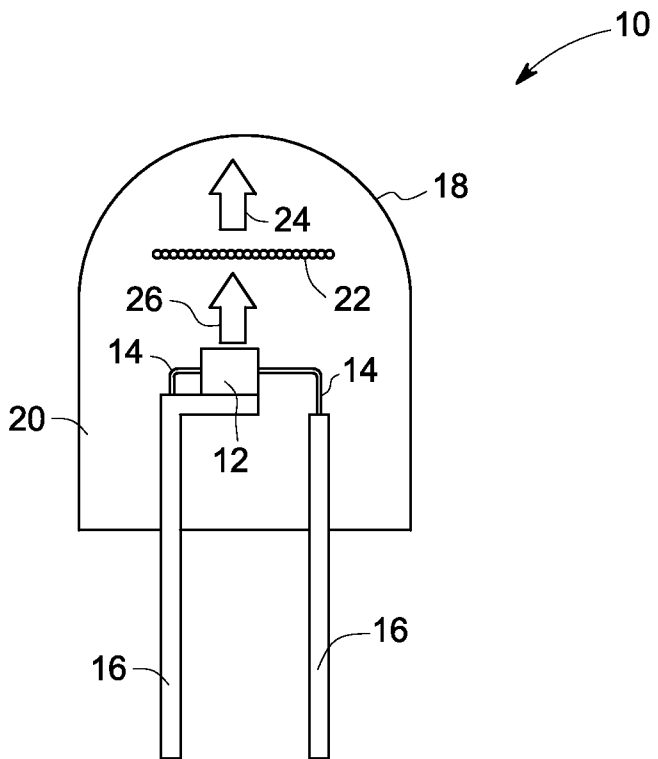

FIG. 2

2/5

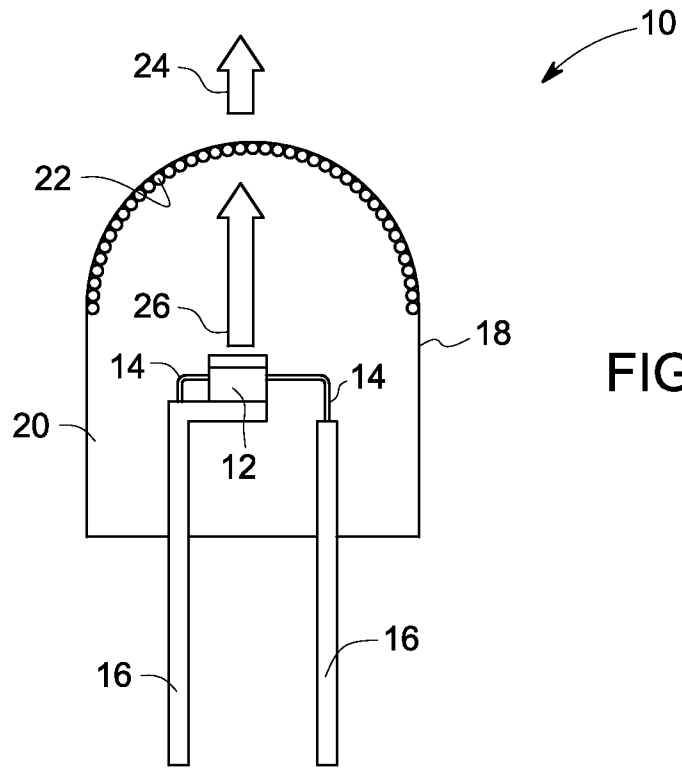

FIG. 3

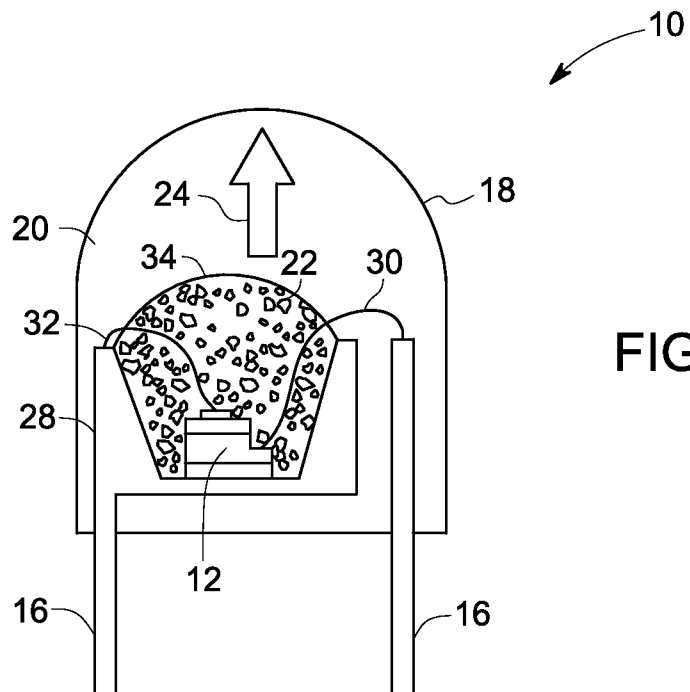

FIG. 4

3/5

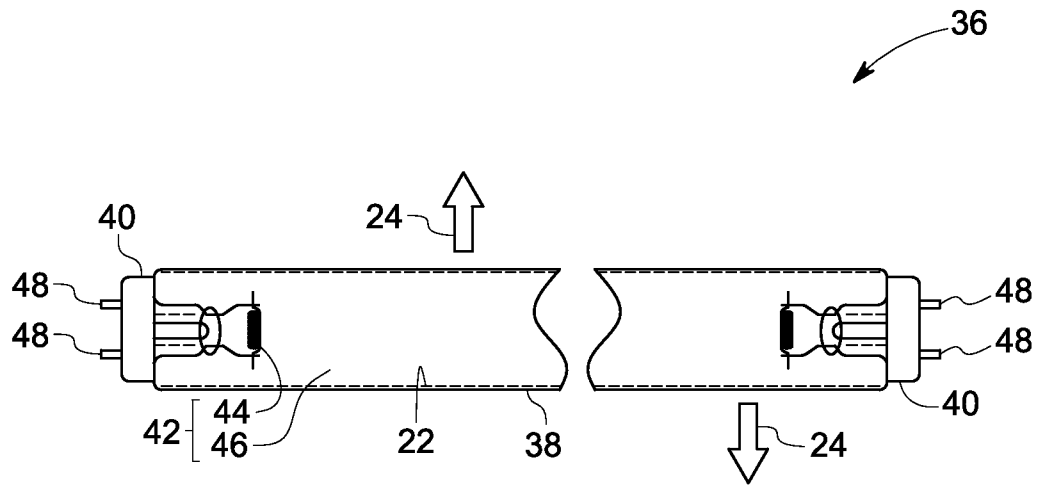

FIG. 5

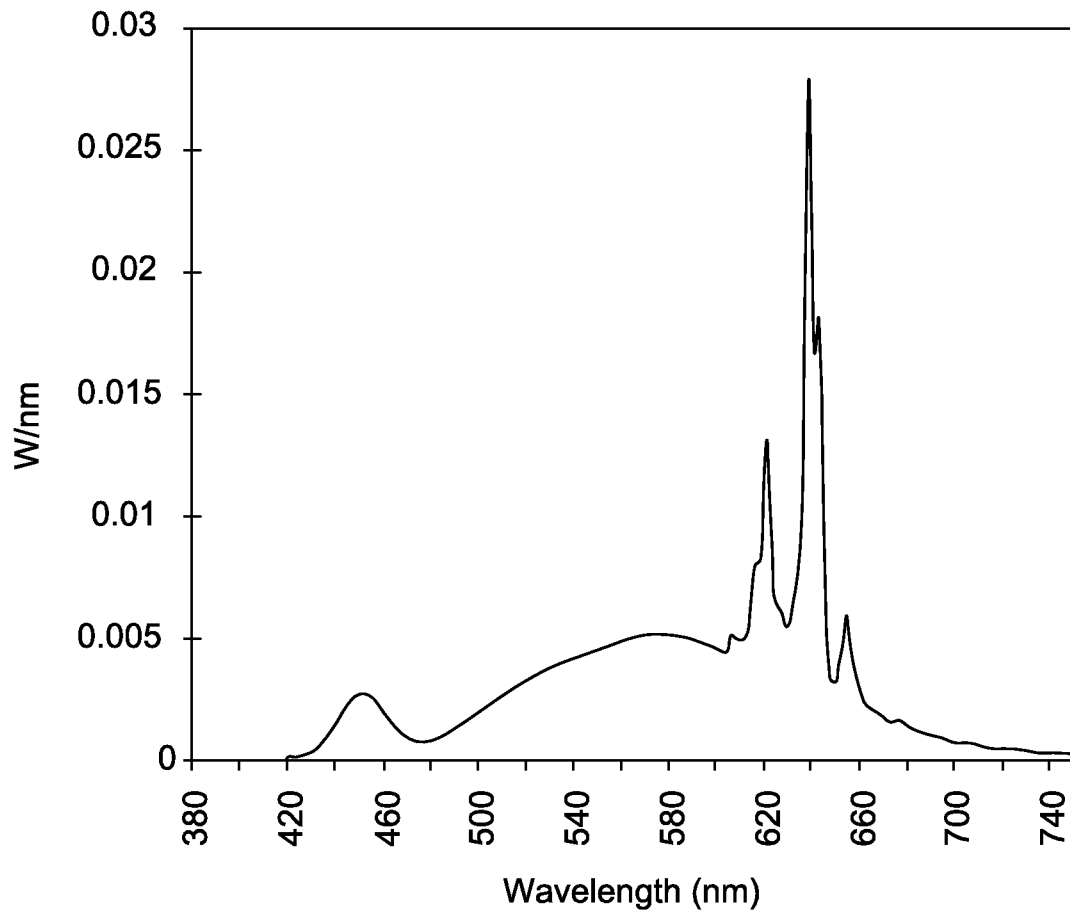

FIG. 6

4/6

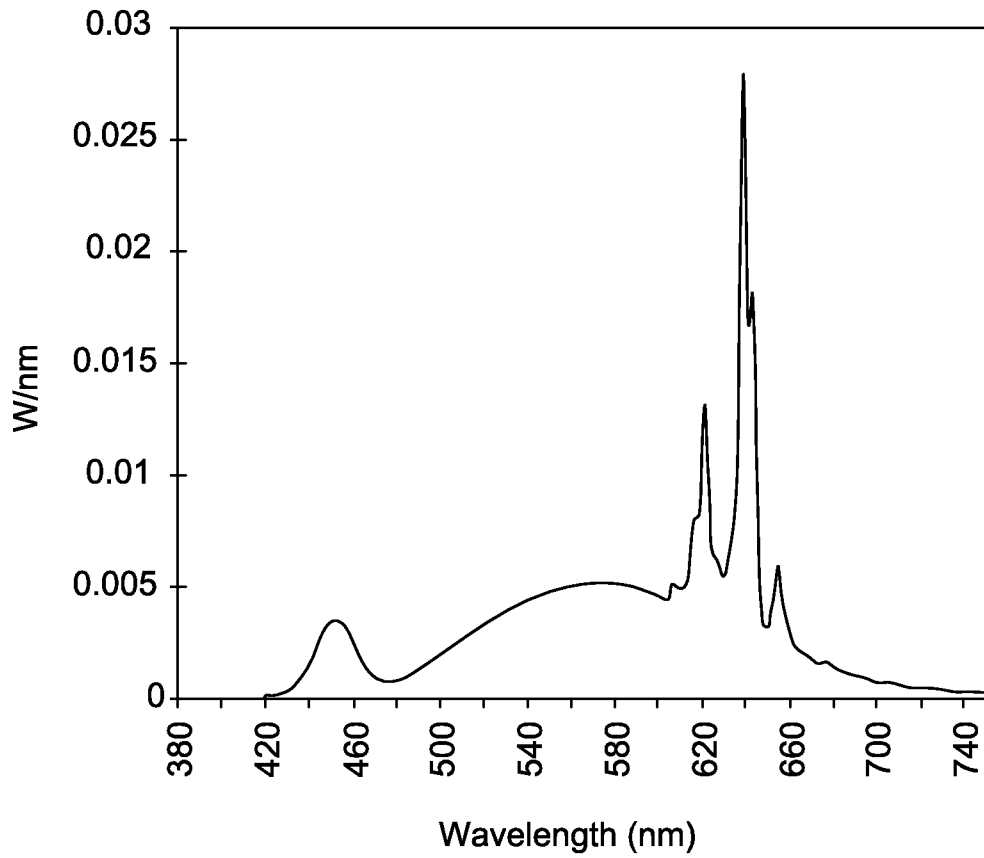

FIG. 7

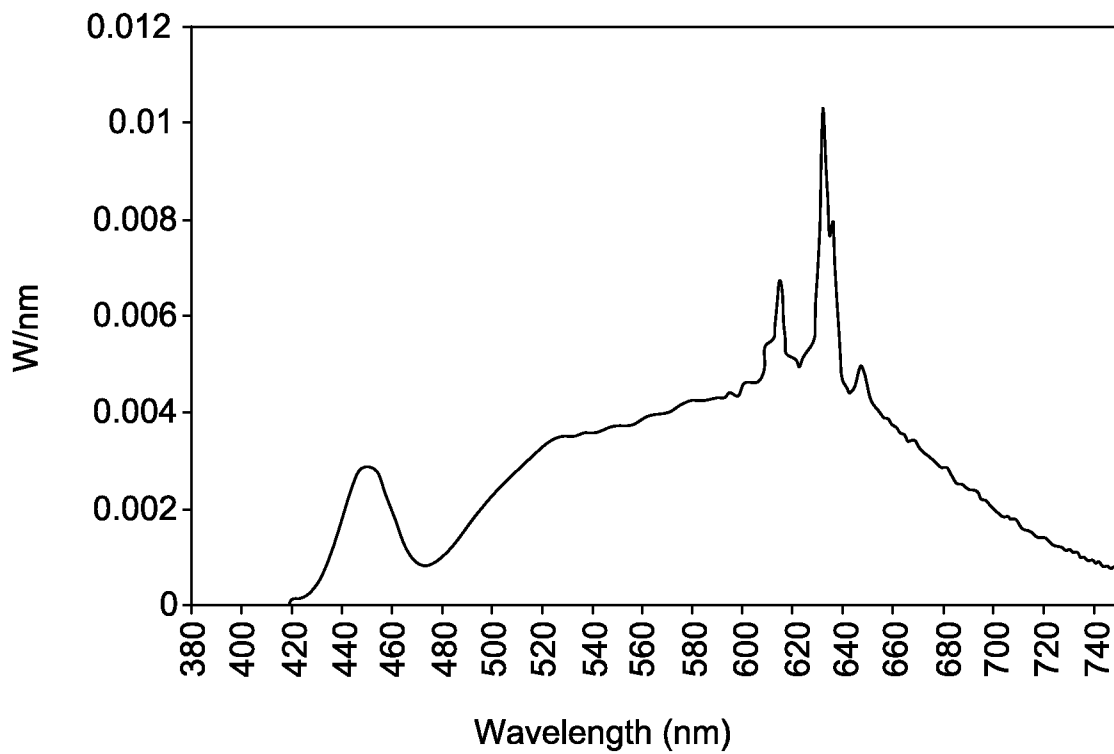

FIG. 8

5/5

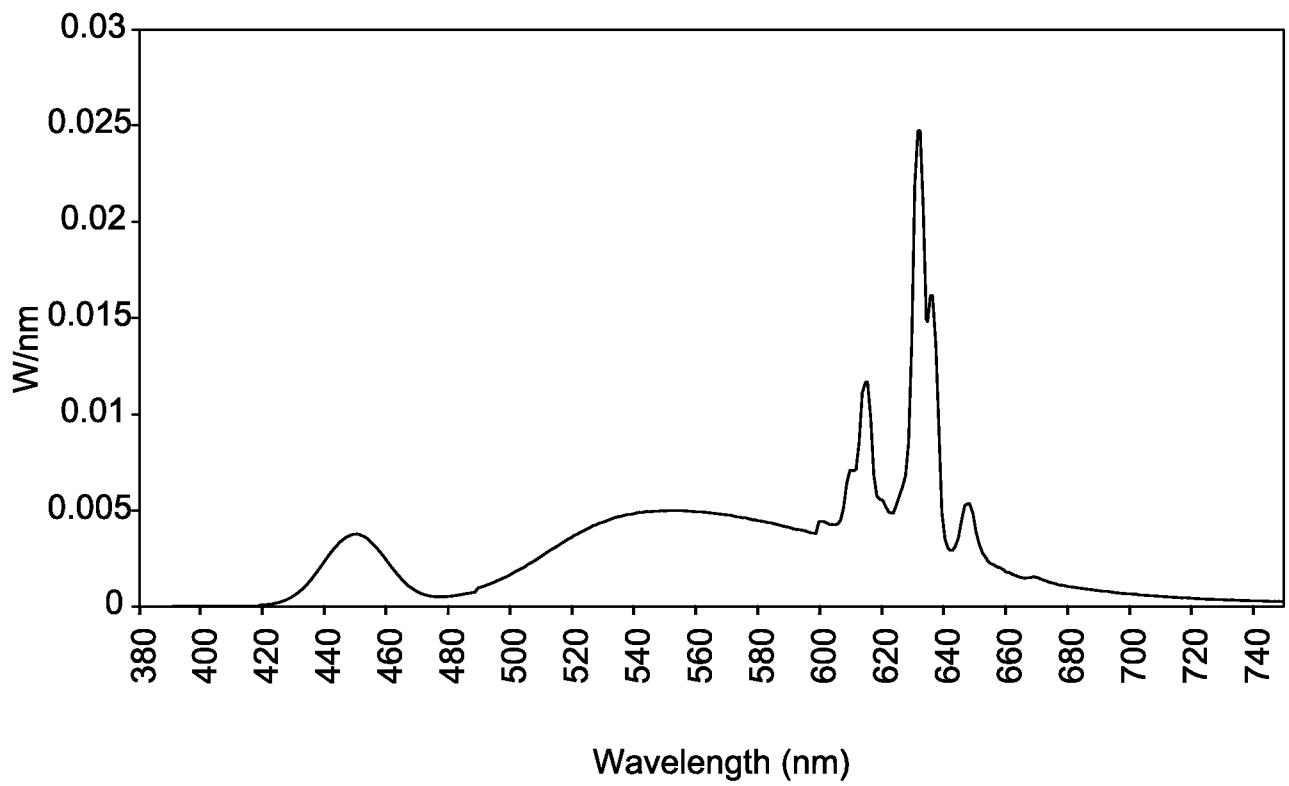

FIG. 9

INTERNATIONAL SEARCH REPORT

International application No PCT/US2012/043426

A. CLASSIFICATION OF SUBJECT MATTER
 INV. C09K11/64 C09K11/61 C09K11/59 H01J61/44
 ADD. H01L33/50

According to International Patent Classification (IPC) or to both national classification and IPC

B. FIELDS SEARCHED
 Minimum documentation searched (classification system followed by classification symbols)
 C09K H01J

Documentation searched other than minimum documentation to the extent that such documents are included in the fields searched

Electronic data base consulted during the international search (name of data base and, where practicable, search terms used)
 EPO-Internal, WPI Data, INSPEC, COMPENDEX

C. DOCUMENTS CONSIDERED TO BE RELEVANT

Category*	Citation of document, with indication, where appropriate, of the relevant passages	Relevant to claim No.
X	US 2010/096974 A1 (SETLUR ANANT ACHYUT [US] ET AL) 22 April 2010 (2010-04-22) paragraph [0037]; claims 1-25; tables 2,3,4	1-25
A	----- US 2011/043101 A1 (MASUDA MASATSUGU [JP] ET AL) 24 February 2011 (2011-02-24) the whole document -----	1-25

Further documents are listed in the continuation of Box C. See patent family annex.

* Special categories of cited documents :

"A" document defining the general state of the art which is not considered to be of particular relevance	"T" later document published after the international filing date or priority date and not in conflict with the application but cited to understand the principle or theory underlying the invention
"E" earlier application or patent but published on or after the international filing date	"X" document of particular relevance; the claimed invention cannot be considered novel or cannot be considered to involve an inventive step when the document is taken alone
"L" document which may throw doubts on priority claim(s) or which is cited to establish the publication date of another citation or other special reason (as specified)	"Y" document of particular relevance; the claimed invention cannot be considered to involve an inventive step when the document is combined with one or more other such documents, such combination being obvious to a person skilled in the art
"O" document referring to an oral disclosure, use, exhibition or other means	"&" document member of the same patent family
"P" document published prior to the international filing date but later than the priority date claimed	

Date of the actual completion of the international search 11 September 2012	Date of mailing of the international search report 19/09/2012
--	--

Name and mailing address of the ISA/ European Patent Office, P.B. 5818 Patentlaan 2 NL - 2280 HV Rijswijk Tel. (+31-70) 340-2040, Fax: (+31-70) 340-3016	Authorized officer Mehdaoui, Imed
--	--

INTERNATIONAL SEARCH REPORT

International application No
PCT/US2012/043426

Patent document cited in search report	Publication date	Patent family member(s)	Publication date
US 2010096974 A1	22-04-2010	CN 101725847 A	09-06-2010
		EP 2180032 A2	28-04-2010
		JP 2010100825 A	06-05-2010
		KR 20100044691 A	30-04-2010
		US 2010096974 A1	22-04-2010

US 2011043101 A1	24-02-2011	CN 101960624 A	26-01-2011
		TW 201000617 A	01-01-2010
		US 2011043101 A1	24-02-2011
		WO 2009110285 A1	11-09-2009
