



(12) **EUROPEAN PATENT APPLICATION**

(43) Date of publication:  
**23.11.2011 Bulletin 2011/47**

(21) Application number: **10163336.0**

(22) Date of filing: **19.05.2010**

(51) Int Cl.:  
**B41F 11/02** (2006.01) **B41F 13/00** (2006.01)  
**B41F 21/08** (2006.01) **B41F 21/10** (2006.01)  
**B41F 23/04** (2006.01) **B41F 23/08** (2006.01)  
**B41F 31/30** (2006.01) **B41M 7/02** (2006.01)  
**B65H 29/00** (2006.01)

(84) Designated Contracting States:  
**AL AT BE BG CH CY CZ DE DK EE ES FI FR GB GR HR HU IE IS IT LI LT LU LV MC MK MT NL NO PL PT RO SE SI SK SM TR**  
 Designated Extension States:  
**BA ME RS**

(71) Applicant: **KBA-NotaSys SA**  
**1000 Lausanne 22 (CH)**

(72) Inventors:  
 • **Schaede, Johannes Georg**  
**97074 Würzburg (DE)**  
 • **Gygi, Matthias**  
**3185 Schmiten (CH)**

(74) Representative: **Noll, Ronald et al**  
**c/o UniConcept IP Solutions Sàrl**  
**Au Trésy 22**  
**1125 Monnaz (CH)**

(54) **Sheet-fed printing press for numbering and varnishing of security documents, especially banknotes**

(57) There is described a sheet-fed printing press for numbering and varnishing of security documents, especially banknotes, including:  
 - a sheet-feeder (01) for feeding in succession printed material in the form of individual sheets carrying multiple security imprints ;  
 - a numbering group (02) comprising at least one numbering unit (21, 22) for numbering the sheets ;  
 - a varnishing group (03) located downstream of the numbering group (02) for applying varnish onto recto and verso sides of said sheets, the varnishing group (03) comprising at least a first varnishing unit (31) for applying varnish on the recto side of the sheets and at least a second varnishing unit (32) for applying varnish on the verso side of the sheets ; and  
 - a sheet-delivery system (04) for collecting varnished sheets coming from the varnishing group (03), the numbering group (02) being coupled to the varnishing group (03) by means of an intermediate sheet gripper system (05) comprising space-apart gripper bars for holding the sheets by a leading edge of the sheets and transporting the sheets from the numbering group (02) to the varnishing group (03).

prising at least a first varnishing unit (31) for applying varnish on the recto side of the sheets and at least a second varnishing unit (32) for applying varnish on the verso side of the sheets ; and  
 - a sheet-delivery system (04) for collecting varnished sheets coming from the varnishing group (03), the numbering group (02) being coupled to the varnishing group (03) by means of an intermediate sheet gripper system (05) comprising space-apart gripper bars for holding the sheets by a leading edge of the sheets and transporting the sheets from the numbering group (02) to the varnishing group (03).

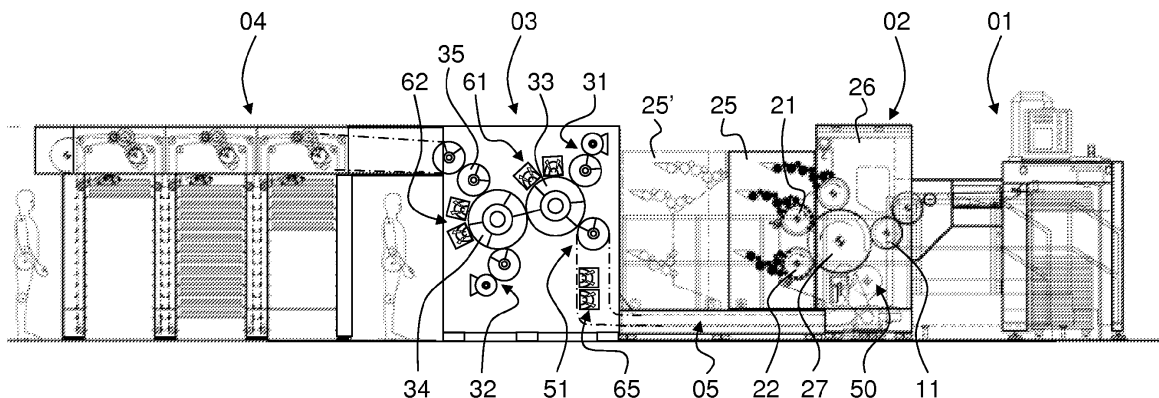

Fig. 1

**Description**PREAMBLE - TECHNICAL FIELD

**[0001]** The present invention generally relates to a sheet-fed printing press for numbering and varnishing of security documents, especially banknotes.

BACKGROUND OF THE INVENTION

**[0002]** Numbering presses for numbering sheets of securities are known in the art. International Publications Nos. WO 2006/129245 A2 and WO 2007/060624 A1, both in the name of the present Applicant and incorporated herein by reference in their entirety, for instance disclose such numbering presses.

**[0003]** Varnishing of banknotes was and is especially carried out to increase the durability and life-cycle of banknotes put into circulation. Information about the varnishing of banknotes can for instance be found in the following papers:

[Buitelaar1999]:

Tom Buitelaar, De Nederlandsche Bank NV, Amsterdam, the Netherlands, "Effects of Banknote varnishing", Currency Conference CSI, Sydney 1999;

[deHeij2000] :

Hans A.M. de Heij, De Nederlandsche Bank NV, Amsterdam, the Netherlands, "The design methodology of Dutch banknotes", IS&T/SPIE's 12th International Symposium on Electronic Imaging, Optical Security and Counterfeit Deterrence Techniques III, San José, California, USA (January 27-28, 2000), Proceedings of SPIE vol. 3973, pp. 2-22;

[Wettstein2000] :

Frank Wettstein, Cash Division, Swiss National Bank, Berne and Hubert Lieb, Environmental Unit, Swiss National Bank, Zurich, "Life cycle assessment (LCA) of Swiss banknotes", Quarterly Bulletin 3/2000 of the Swiss National Bank, September 2000;

[Buitelaar2003] :

Tom Buitelaar, De Nederlandsche Bank NV, Amsterdam, the Netherlands, "Circulation Fitness Management", Banknote 2003 Conference, Washington DC, February 3, 2003 ;

**[0004]** Further information about the varnishing of banknotes and like security documents might be found in

European Patent Publications Nos. EP 0 256 170 A1, EP 1 936 678 A1 and International Publications Nos. WO 01/08899 A1, WO 02/094577 A1, and WO 2006/021856 A1.

**[0005]** Varnishing presses for varnishing sheets or a continuous web of securities are also known in the art. International Publications Nos. WO 02/051638 A1 and WO 2010/023598 A1, and European Patent Publication No. EP 0 976 555 A1 for instance disclose such varnishing presses.

**[0006]** WO 02/051638 A1 specifically discloses a stand-alone a flexographic printing press which can be used for varnishing of banknotes comprising at least a first flexographic unit disposed above the path of the sheets for cooperation with a recto side of the sheets and at least a second flexographic unit disposed downstream of the first flexographic unit and below the path of the sheets for cooperation with a verso side of the sheets. According to WO 02/051638 A1, the two flexographic units are separated by at least two intermediate cylinders and the second flexographic unit is offset in height with respect to the first flexographic unit.

**[0007]** EP 0 976 555 A1 specifically discloses a sheet-fed coating system consisting of multiple coating units disposed one after the other along the path of the sheets, the coating units being located both above and below the path of the sheets. According to EP 0 976 555 A1, such coating system can be coupled directly after a conventional offset printing group or combined with additional offset printing units. All of the configurations envisaged in EP 0 976 555 A1 share a generally similar configuration with multiple printing or coating towers disposed one after the other along the path of the sheets, which configuration is similar to that of conventional printing presses used for non-security applications and requires a rather considerable footprint.

SUMMARY OF THE INVENTION

**[0008]** A general aim of the invention is to provide a sheet-fed printing press that suitably combines numbering and varnishing in a single pass.

**[0009]** A further aim of the invention is to provide such a printing press that is as compact as possible, while still ensuring ease of maintenance of and proper accessibility to the various components of the numbering and varnishing groups.

**[0010]** These aims are achieved thanks to the printing press defined in the claims.

**[0011]** There is accordingly provided a sheet-fed printing press for numbering and varnishing of security documents, especially banknotes, including:

- a sheet-feeder for feeding in succession printed material in the form of individual sheets carrying multiple security imprints ;
- a numbering group comprising at least one numbering unit for numbering the sheets ;
- a varnishing group located downstream of the num-

bering group for applying varnish onto recto and verso sides of the sheets, the varnishing group comprising at least a first varnishing unit for applying varnish on the recto side of the sheets and at least a second varnishing unit for applying varnish on the verso side of the sheets ; and

- a sheet-delivery system for collecting varnished sheets coming from the varnishing group,

the numbering group being coupled to the varnishing group by means of an intermediate sheet gripper system comprising space-apart gripper bars for holding the sheets by a leading edge of the sheets and transporting the sheets from the numbering group to the varnishing group.

**[0012]** According to a preferred embodiment of the invention, the numbering group further comprises a movable carriage, preferably a movable inking carriage, that can be retracted away from or be coupled to a stationary part of the numbering group. In such a case, the intermediate sheet gripper system advantageously runs below the movable carriage.

**[0013]** Further advantageous embodiments of the invention form the subject-matter of the dependent claims and are discussed below.

#### BRIEF DESCRIPTION OF THE DRAWINGS

**[0014]** Features and advantages of the present invention will appear more clearly from reading the following detailed description of embodiments of the invention which are presented solely by way of non-restrictive examples and are illustrated by the attached drawings in which:

Figure 1 is a schematic side view of a printing press according to a preferred embodiment of the invention ; and

Figure 2 is an enlarged schematic side view of the varnishing group of the printing press of Figure 1.

#### DETAILED DESCRIPTION OF EMBODIMENTS OF THE INVENTION

**[0015]** A preferred embodiment of the invention will be described in reference to Figures 1 and 2 which illustrate a sheet-fed printing press.

**[0016]** Figure 1 is a schematic side view of the preferred embodiment of the printing press which includes in this example a sheet-feeder 01 for feeding individual sheets in succession, which sheets carry multiple security imprints that are typically arranged in the form of a matrix. These sheets are first fed to a numbering group 02 which comprises at least one numbering unit for numbering the sheets and then from the numbering group 02 to a downstream located varnishing group 03 for applying varnish onto recto and verso sides of the sheets. To this end, the varnishing group 03 comprises at least a first

varnishing unit 31 for applying varnish on the recto side of the sheets and at least a second varnishing unit 32 for applying varnish on the verso side of the sheets. The first and second varnishing units 31, 32 are respectively disposed above and below the path of the sheets.

**[0017]** Once varnished on the recto and verso sides, the sheets are transferred to a sheet-delivery system 04 known as such in the art which collects the varnished sheets coming from the varnishing group 03.

**[0018]** The numbering group 02 and varnishing group 03 are advantageously coupled to one another by means of an intermediate sheet gripper system 05 comprising space-apart gripper bars for holding the sheets by a leading edge thereof and transporting the sheets from the numbering group 02 to the varnishing group 03. This intermediate sheet gripper system 05 consists of endless chains disposed between pairs of chain wheels located at upstream 50 and downstream ends 51, the endless chains being constantly driven during operation (in this example in the clockwise direction). Gripper bars (not shown) are mounted transversely to the path of the sheets between the chains and at constant intervals to suitably take sheets away from the numbering group 02 to deliver those to the downstream-located varnishing group 03.

**[0019]** The numbering group 02 is as such identical to the numbering group disclosed in International Publications Nos. WO 2006/129245 A2 and WO 2007/060624 A1, both in the name of the present Applicant. The disclosure thereof is incorporated herein by reference. The configuration of the numbering group 02 will not therefore be described in detail here as one can refer to the above-listed International Publications. It suffices to understand that this numbering group 02 comprises a stationary part 26 (or printing unit) housing in particular a transport cylinder 27 (or impression cylinder) which transports the sheets being supplied from the sheet-feeder 01 by an upstream located transfer cylinder (or drum as the case may be) 11. The transport cylinder 27, which rotates in this example in the counter-clockwise direction, transports the sheets past first and second numbering units 21, 22. An optional printing unit (not referenced) is provided upstream of the first printing unit 21. Once numbered, the sheets are taken away from the transport cylinder 27 at the upstream end 50 of the intermediate sheet gripper system 05.

**[0020]** As illustrated in Figure 1, the numbering group 02 preferably comprises a mobile carriage 25 (which acts in this case as an inking carriage) that can be retracted away from or be coupled to the stationary part 26 of the numbering group 02. Reference numeral 25 designates the mobile carriage (which is depicted in continuous lines in Figure 1) in a working position, i.e. coupled to the stationary part 26, while reference numeral 25' designates the mobile carriage (which is depicted in dashed lines in Figure 1) in a maintenance position, i.e. retracted away from the stationary part 26.

**[0021]** It will be appreciated that Figure 1 shows that

the intermediate sheet gripper system 05 runs below the movable carriage 25, 25' which ensures that maintenance operations and access to the numbering group 02 are not compromised.

**[0022]** The numbering group 02 and varnishing group 03 are preferably constructed as modular groups that can easily be decoupled from one another. Even more preferably, transfer of a sheet from the intermediate sheet gripper system 05 to the varnishing group 03 is performed at a location which corresponds in height to a location where the sheet is transferred from the transfer cylinder or drum 11 to the transport cylinder 27 of the numbering group 02. In this way, the varnishing group 03 can potentially be coupled directly to the sheet in-feed system (i.e. downstream of the transfer cylinder 11) should it be needed to omit the numbering group 02.

**[0023]** Figure 2 illustrates in greater detail the varnishing group 03 of the printing press of Figure 1. It shows in particular a first cylinder or drum 33 located below the path of the sheets and cooperating with the first varnishing unit 31 which is disposed above the path of the sheets. It further shows a second cylinder or drum 34 located above the path of the sheets and cooperating with the second varnishing unit 32 which is disposed below the path of the sheets, which second cylinder or drum 34 is located immediately after the first cylinder or drum 33 to ensure direct transfer of the sheets from the first cylinder or drum 33 to the second cylinder or drum 34.

**[0024]** The first and second varnishing units (and additional varnishing units that may be provided if necessary) are preferably flexographic units consisting of anilox roller 310, respectively 320, which is inked by an associated ink chamber (not referenced) and cooperates with an associated forme cylinder 311, respectively 321, that carries a flexographic printing plate. This printing plate can be designed to apply varnish over substantially all of the corresponding side of the sheets or, as the case may be, to apply varnish only on selected areas of the sheets, in which latter case the flexographic printing plate is provided with corresponding ink transferring areas.

**[0025]** A transfer cylinder or drum 35 is provided to suitably transfer the sheets from the second cylinder 34 to the sheet-delivery system 04, which sheet-delivery system 04 transports the sheets in the clockwise direction in this example. This transfer cylinder or drum 35 may be omitted should the sheet-delivery system 04 be designed to transport the sheets in the counter-clockwise direction, or additional transfer cylinders or drums may be provided if necessary.

**[0026]** At least a first drying unit 61 is further provided for drying the recto side of the sheets following varnishing by the first varnishing unit 31 and prior to transfer of the printed material to the second cylinder or drum 34. Similarly, at least a second drying unit 62 for drying the verso side of the sheets following varnishing by the second varnishing unit 32 is provided. These drying units 61, 62 preferably include UV drying lamps in case of varnishing using UV-cured varnishes.

**[0027]** An intermediate drying unit 65 (shown in Figures 1 and 2) is also provided along the path of the sheets between the numbering group 02 and varnishing group 03 for drying the sheets which have been numbered on the numbering group 02.

**[0028]** Various modifications and/or improvements may be made to the above-described embodiments without departing from the scope of the invention as defined by the annexed claims.

**[0029]** For instance, the printing press may be modified to additionally include an inspection group placed upstream of the numbering group 02 for carrying out inspection of the printed material and determining occurrence of defects affecting the quality of the printed material prior to numbering and varnishing. Such an inspection group may be an inspection group as disclosed in International Publication Nos. WO 2005/008605 A1 and WO 2005/008606 A1, both in the name of the present Applicant and incorporated herein by reference.

**[0030]** Additional printing or processing units may be provided, such as for instance a laser marking unit.

#### LIST OF REFERENCES USED IN THE FIGURES AND SPECIFICATION

##### **[0031]**

01	sheet-feeder
02	numbering group
03	varnishing group
04	sheet-delivery system
05	intermediate sheet gripper system comprising space-apart gripper bars for holding the sheets by a leading edge thereof
11	sheet transfer cylinder or drum for transfer of successive sheets from sheet-feeder 01 to numbering group 02
21	(first) numbering unit / cylinder of numbering group 02
22	(second) numbering unit / cylinder of numbering group 02
25	mobile (inking) carriage of numbering group 02 (in working position)
25'	mobile (inking) carriage of numbering group 02 (in retracted position for maintenance)
26	stationary part (printing unit) of numbering group 02

- |               |  |    |  |
|---------------|--|----|--|
| 27            | transport (impression) cylinder of numbering group 02  |    | - a numbering group (02) comprising at least one numbering unit (21, 22) for numbering the sheets ;  |
| 31            | first varnishing unit (flexographic unit) for varnishing of recto side of the sheets   | 5  | - a varnishing group (03) located downstream of said numbering group (02) for applying varnish onto recto and verso sides of said sheets, said varnishing group (03) comprising at least a first varnishing unit (31) for applying varnish on the recto side of the sheets and at least a second varnishing unit (32) for applying varnish on the verso side of the sheets ; and   |
| 32            | second varnishing unit (flexographic unit) for varnishing of verso side of the sheets  |    | - a sheet-delivery system (04) for collecting varnished sheets coming from the varnishing group (03),  |
| 33            | first cylinder or drum cooperating with first varnishing unit 31   | 10 | said numbering group (02) being coupled to said varnishing group (03) by means of an intermediate sheet gripper system (05) comprising space-apart gripper bars for holding the sheets by a leading edge of the sheets and transporting the sheets from the numbering group (02) to the varnishing group (03).   |
| 34            | second cylinder or drum cooperating with second varnishing unit 32   | 15 |  |
| 35            | transfer cylinder for transferring of varnished sheets from second cylinder or drum 34 to sheet-delivery system 04   |    |  |
| 50            | upstream end of intermediate sheet gripper system 05 where the sheets are taken away from the numbering group 02   | 20 |  |
| 51            | downstream end of intermediate sheet gripper system 05 where the sheets are delivered to the varnishing group 03   | 25 | 2. The printing press as defined in claim 1, wherein said numbering group (02) further comprises a movable carriage (25, 25'), preferably a movable inking carriage, that can be retracted away from or be coupled to a stationary part (26) of the numbering group (02).  |
| 61            | first drying unit for drying the recto side of the sheets following varnishing by the first varnishing unit 31 prior to transfer of the sheets to the second cylinder or drum 34 | 30 | 3. The printing press as defined in claim 2, wherein said intermediate sheet gripper system (05) runs below said movable carriage (25, 25').   |
| 62            | second drying unit for drying the verso side of the sheets following varnishing by the second varnishing unit 32   | 35 | 4. The printing press as defined in any one of the preceding claims, wherein said numbering group (02) and varnishing group (03) are constructed as modular groups that can easily be decoupled from one another.  |
| 65            | intermediate drying unit for drying the sheets along the path of the sheets between the numbering group 02 and varnishing group 03   | 40 | 5. The printing press as defined in any one of claims 1 to 3, wherein said numbering group (02) and varnishing group (03) are constructed as modular groups that can easily be decoupled from one another and wherein transfer of a sheet to the numbering group (20) is performed by means of a sheet transfer cylinder or drum (11) cooperating with a transport cylinder (27) of said numbering group (02) and wherein transfer of a sheet from the intermediate sheet gripper system (05) to the varnishing group (03) is performed at a location which corresponds in height to a location where the sheet is transferred from the transfer cylinder or drum (11) to the transport cylinder (27) of the numbering group (02). |
| 310           | anilox roller of first varnishing unit 31  |    |  |
| 311           | forme cylinder of first varnishing unit 31   |    |  |
| 320           | anilox roller of second varnishing unit 32   | 45 |  |
| 321           | forme cylinder of second varnishing unit 32  |    |  |
| <b>Claims</b> |  | 50 |  |
| 1.            | A sheet-fed printing press for numbering and varnishing of security documents, especially banknotes, including:  | 55 | 6. The printing press as defined in any one of the preceding claims, further comprising an inspection group placed upstream of said numbering group (02) for carrying out inspection of said sheets and determining occurrence of defects affecting the quality of   |
|               | - a sheet-feeder (01) for feeding in succession printed material in the form of individual sheets carrying multiple security imprints ;  |    |  |

said sheets prior to numbering and varnishing.

7. The printing press as defined in any one of the preceding claims, wherein said varnishing group (03) comprises: 5
- a first cylinder or drum (33) located below the path of said sheets and cooperating with said at least first varnishing unit (31) which is disposed above the path of said sheets ; and 10
  - a second cylinder or drum (34) located above the path of said sheets and cooperating with said at least second varnishing unit (32) which is disposed below the path of said sheets, 15  
said second cylinder or drum (34) being located immediately after said first cylinder or drum (33) to ensure direct transfer of said sheets from the first cylinder or drum (33) to the second cylinder or drum (34). 20
8. The printing press as defined in claim 7, further comprising at least a first drying unit (61) for drying the recto side of the sheets following varnishing by said at least first varnishing unit (31) prior to transfer of the sheets to the second cylinder or drum (34) and at least a second drying unit (62) for drying the verso side of the sheets following varnishing by said at least second varnishing unit (32). 25
9. The printing press as defined in any one of the preceding claims, further comprising an intermediate drying unit (65) for drying the sheets, which intermediate drying unit (65) is located along the path of said sheets between the numbering group (02) and varnishing group (03). 30  
35

40

45

50

55

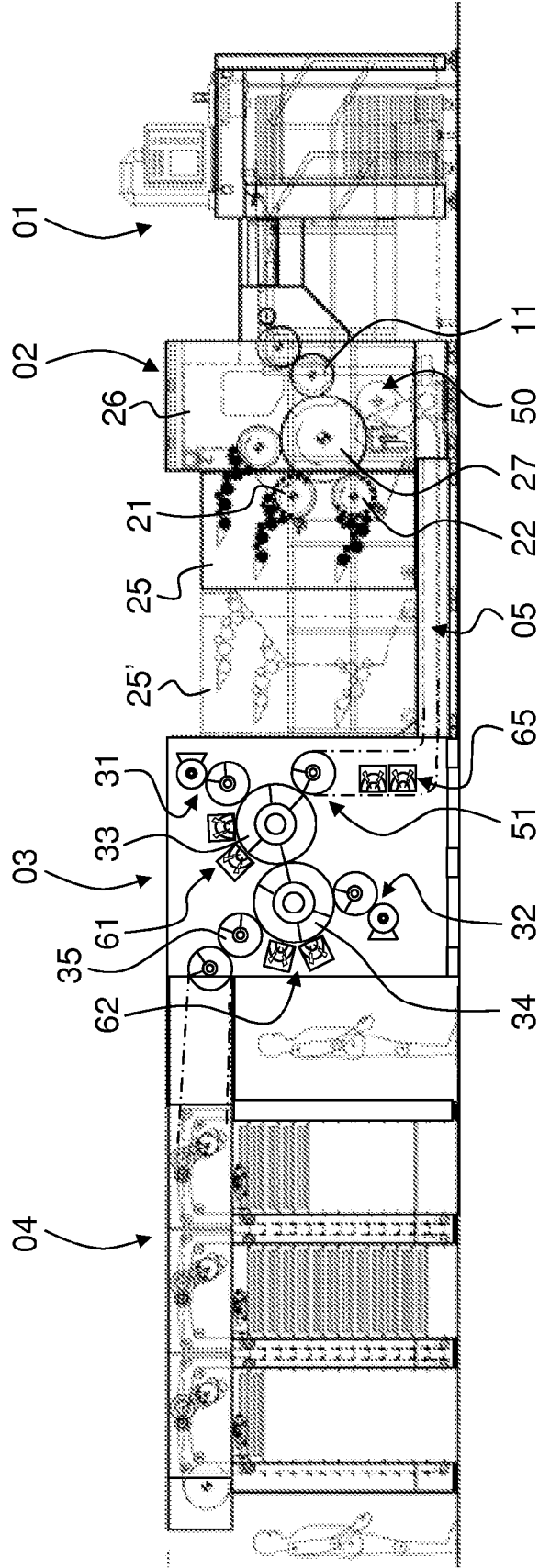

Fig. 1

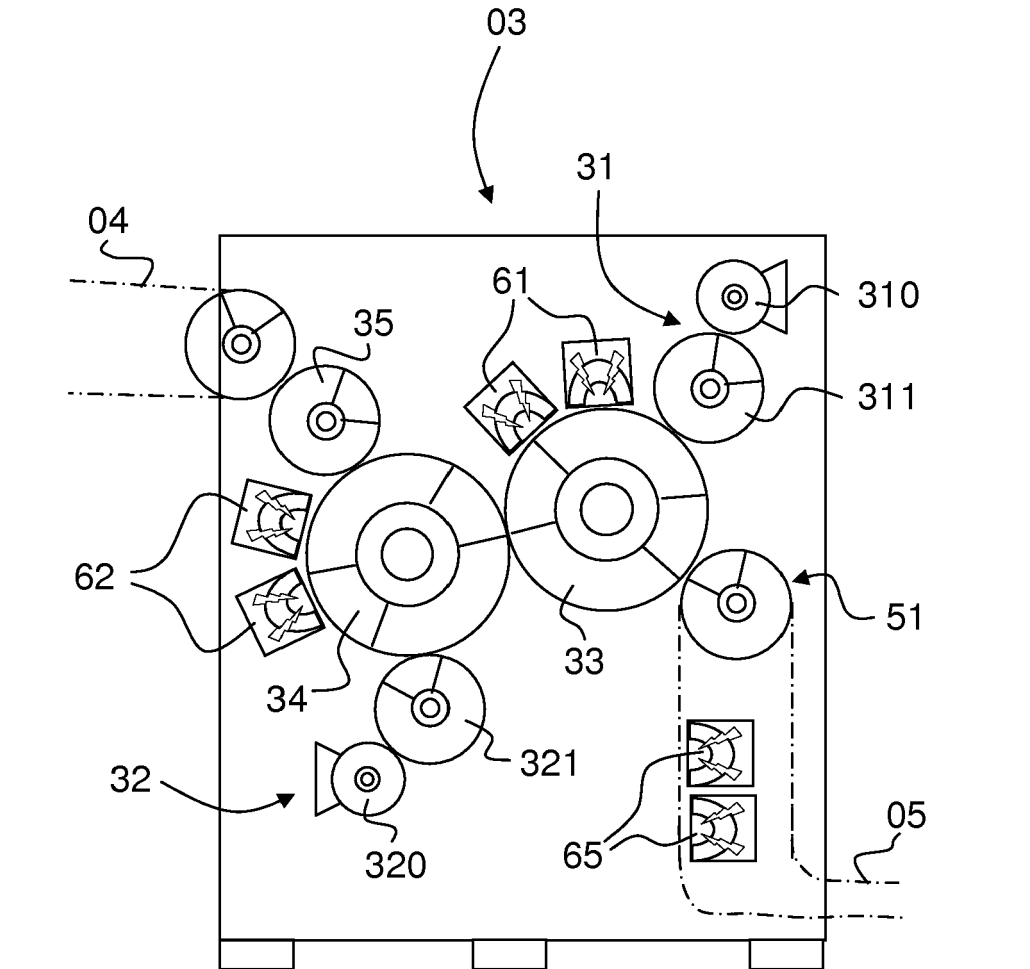

Fig. 2





EUROPEAN SEARCH REPORT

Application Number  
EP 10 16 3336

DOCUMENTS CONSIDERED TO BE RELEVANT			
Category	Citation of document with indication, where appropriate, of relevant passages	Relevant to claim	CLASSIFICATION OF THE APPLICATION (IPC)
X,D	EP 0 976 555 A1 (KOMORI PRINTING MACH [JP]) 2 February 2000 (2000-02-02)	1,7,8	INV. B41F11/02
Y	* figures 1,2 * * paragraphs [0010] - [0012], [0017], [0020] *	2-6,9	B41F13/00 B41F21/08 B41F21/10 B41F23/04
Y,D	WO 2006/129245 A2 (KBA GIORI SA [CH];STOEHR [DE];KUEHN [DE]; SCHWITZKY [DE];SCHAEDE [DE]) 7 December 2006 (2006-12-07)	2,3	B41F23/08 B41F31/30 B41M7/02 B65H29/00
Y	DE 197 32 796 A1 (HEIDELBERGER DRUCKMASCH AG [DE]) 9 April 1998 (1998-04-09)	4,5	
	* figure 1 * * column 2, lines 8-38 *		
Y,D	WO 2005/008606 A1 (KBA GIORI SA[CH];REINHARD [DE];SCHWITZKY [DE];STOEHR [DE];SCHAEDE [DE]) 27 January 2005 (2005-01-27)	6	TECHNICAL FIELDS SEARCHED (IPC) B41F
	* figure 1 * * page 5, lines 30-33 * * page 6, lines 16-20 *		
Y	EP 1 886 814 A2 (KOMORI PRINTING MACH [JP]) 13 February 2008 (2008-02-13)	9	
	* figure 7 * * paragraphs [0004], [0088], [0101] *		
A	EP 1 980 393 A1 (KBA GIORI SA [CH]) 15 October 2008 (2008-10-15)	1-9	
	* figure 1 * * paragraph [0010] *		
The present search report has been drawn up for all claims			
Place of search Munich		Date of completion of the search 5 October 2010	Examiner Hajji, Mohamed-Karim
CATEGORY OF CITED DOCUMENTS X : particularly relevant if taken alone Y : particularly relevant if combined with another document of the same category A : technological background O : non-written disclosure P : intermediate document		T : theory or principle underlying the invention E : earlier patent document, but published on, or after the filing date D : document cited in the application L : document cited for other reasons & : member of the same patent family, corresponding document	

1  
EPO FORM 1503 03.82 (P04C01)

**ANNEX TO THE EUROPEAN SEARCH REPORT  
ON EUROPEAN PATENT APPLICATION NO.**

EP 10 16 3336

This annex lists the patent family members relating to the patent documents cited in the above-mentioned European search report. The members are as contained in the European Patent Office EDP file on The European Patent Office is in no way liable for these particulars which are merely given for the purpose of information.

05-10-2010

Patent document cited in search report	Publication date	Patent family member(s)	Publication date	
EP 0976555	A1	02-02-2000	AT 231440 T	15-02-2003
			DE 69904995 D1	27-02-2003
			DE 69904995 T2	13-11-2003
			ES 2194421 T3	16-11-2003
			JP 2000103035 A	11-04-2000
			US 6338299 B1	15-01-2002
WO 2006129245	A2	07-12-2006	CN 101511594 A	19-08-2009
			EP 1728628 A1	06-12-2006
			JP 2008542078 T	27-11-2008
			US 2009101030 A1	23-04-2009
DE 19732796	A1	09-04-1998	DE 29617261 U1	21-11-1996
WO 2005008606	A1	27-01-2005	CN 1836260 A	20-09-2006
			DE 10332211 B3	10-02-2005
			EP 1644901 A1	12-04-2006
			JP 2007523761 T	23-08-2007
			RU 2329540 C2	20-07-2008
			US 2006208412 A1	21-09-2006
EP 1886814	A2	13-02-2008	CN 101122106 A	13-02-2008
			JP 2008037036 A	21-02-2008
			US 2008037401 A1	14-02-2008
EP 1980393	A1	15-10-2008	AT 477927 T	15-09-2010
			CN 101743124 A	16-06-2010
			EP 2139685 A1	06-01-2010
			WO 2008126005 A1	23-10-2008
			JP 2010523377 T	15-07-2010
			US 2010139463 A1	10-06-2010

**REFERENCES CITED IN THE DESCRIPTION**

*This list of references cited by the applicant is for the reader's convenience only. It does not form part of the European patent document. Even though great care has been taken in compiling the references, errors or omissions cannot be excluded and the EPO disclaims all liability in this regard.*

**Patent documents cited in the description**

- WO 2006129245 A2 [0002] [0019]
- WO 2007060624 A1 [0002] [0019]
- EP 0256170 A1 [0004]
- EP 1936678 A1 [0004]
- WO 0108899 A1 [0004]
- WO 02094577 A1 [0004]
- WO 2006021856 A1 [0004]
- WO 02051638 A1 [0005] [0006]
- WO 2010023598 A1 [0005]
- EP 0976555 A1 [0005] [0007]
- WO 2005008605 A1 [0029]
- WO 2005008606 A1 [0029]

**Non-patent literature cited in the description**

- **TOM BUITELAAR.** Effects of Banknote varnishing. *Currency Conference CSI*, 1999 [0003]
- **HANS A.M. DE HEIJ.** The design methodology of Dutch banknotes. *IS&T/SPIE's 12th International Symposium on Electronic Imaging, Optical Security and Counterfeit Deterrence Techniques III*, 27 January 2000 [0003]
- *Proceedings of SPIE*, vol. 3973, 2-22 [0003]
- Life cycle assessment (LCA) of Swiss banknotes. **FRANK WETTSTEIN.** Quarterly Bulletin 3/2000 of the Swiss National Bank. September 2000 [0003]
- **TOM BUITELAAR.** Circulation Fitness Management. *Banknote 2003 Conference*, 03 February 2003 [0003]