



US 20060265074A1

(19) **United States**

(12) **Patent Application Publication**  
**Krishna et al.**

(10) **Pub. No.: US 2006/0265074 A1**

(43) **Pub. Date: Nov. 23, 2006**

(54) **POSTERIOR SPINAL  
ARTHROPLASTY-DEVELOPMENT OF A  
NEW POSTERIORLY INSERTED  
ARTIFICIAL DISC, A NEW ANTERIORLY  
INSERTED ARTIFICIAL DISC AND AN  
ARTIFICIAL FACET JOINT**

**Publication Classification**

(51) **Int. Cl.**  
*A61F 2/44* (2006.01)  
*A61B 17/70* (2006.01)  
(52) **U.S. Cl.** ..... **623/17.15**; 623/17.14; 606/61

(76) Inventors: **Manoj Krishna**, Yarm (GB); **Tai Friesem**, Ingleby (GB)

(57) **ABSTRACT**

A lumbar disc prosthesis is provided including a pair of disc members. The first member of the disc pair has a vertebral disc contact surface and a recessed portion on an opposing surface thereof. The second member of the disc pair has a vertebral disc contact surface and a protruding portion on an opposing surface thereof. The protruding portion of the second member engages with the recessed portion of the first member in use. Each of the first and second disc members are provided with at least three sections; a middle section and two end sections. The recessed and protruding portions are provided in the middle section of the respective disc members and each of the two end sections have a narrowing taper towards the ends of the disc members. The facet joint prosthesis includes a first member for attachment to a first posterior lumbar disc in use and a second member for attachment to a second posterior lumbar disc in use. At least a part of the first member is telescopically mounted in at least a part of the second member in use.

Correspondence Address:

**Michael E. Sellers**  
**Gable & Gotwals**  
**10th Floor**  
**100 W. 5th Street**  
**Tulsa, OK 74103 (US)**

(21) Appl. No.: **11/397,756**

(22) Filed: **Apr. 4, 2006**

**Related U.S. Application Data**

(63) Continuation-in-part of application No. 11/203,259, filed on Aug. 12, 2005, which is a continuation-in-part of application No. 10/970,091, filed on Oct. 21, 2004.

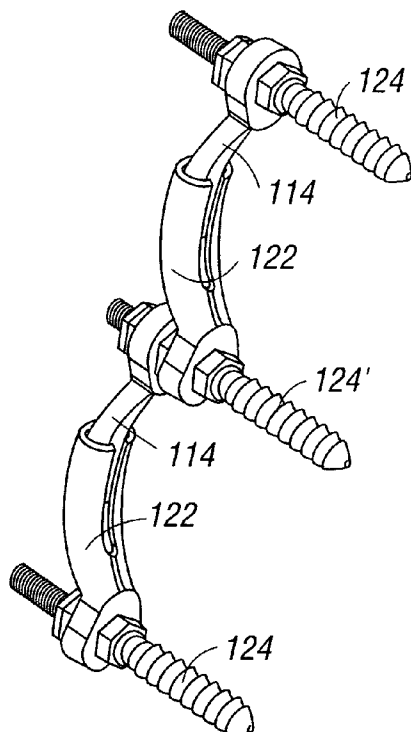

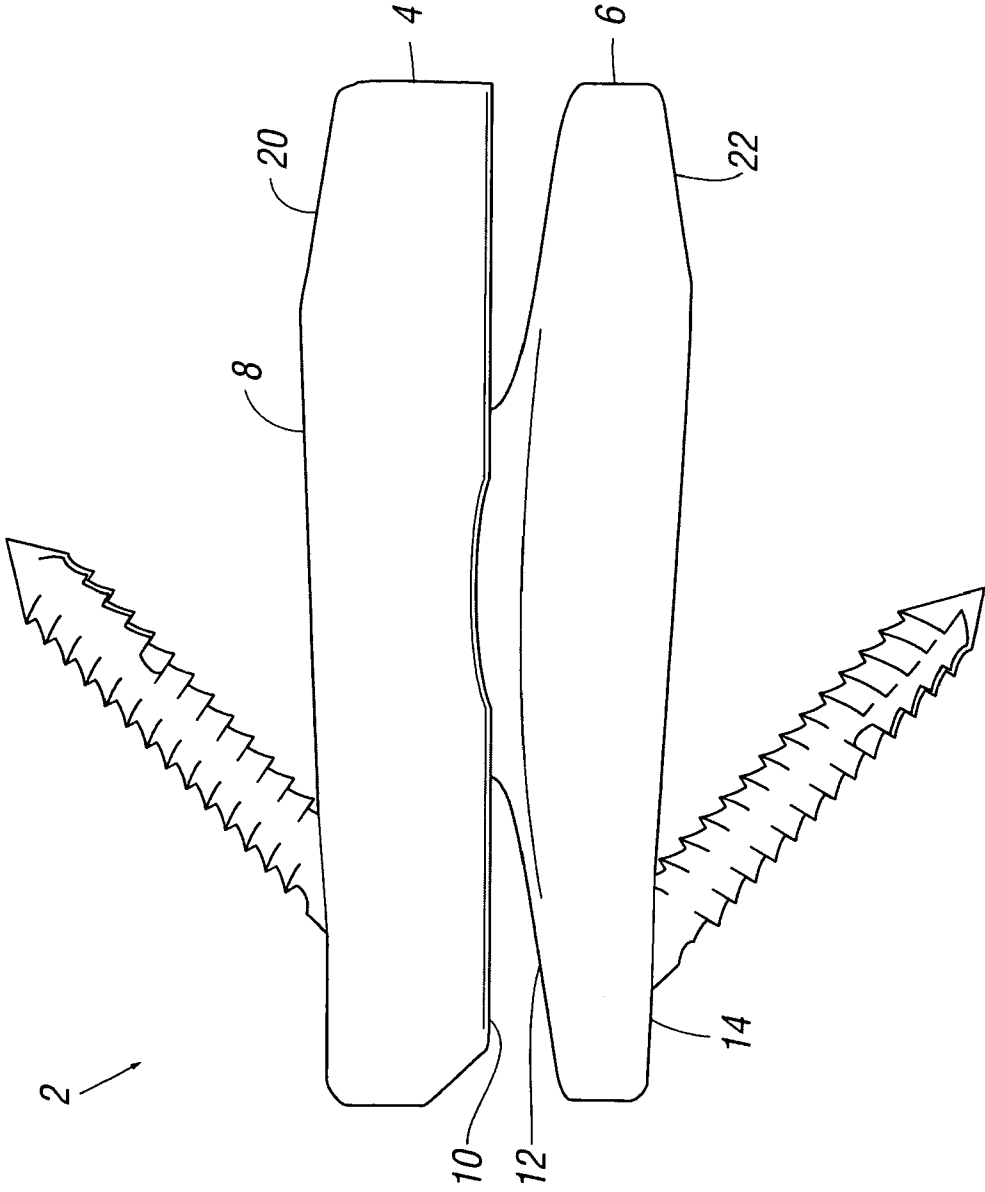
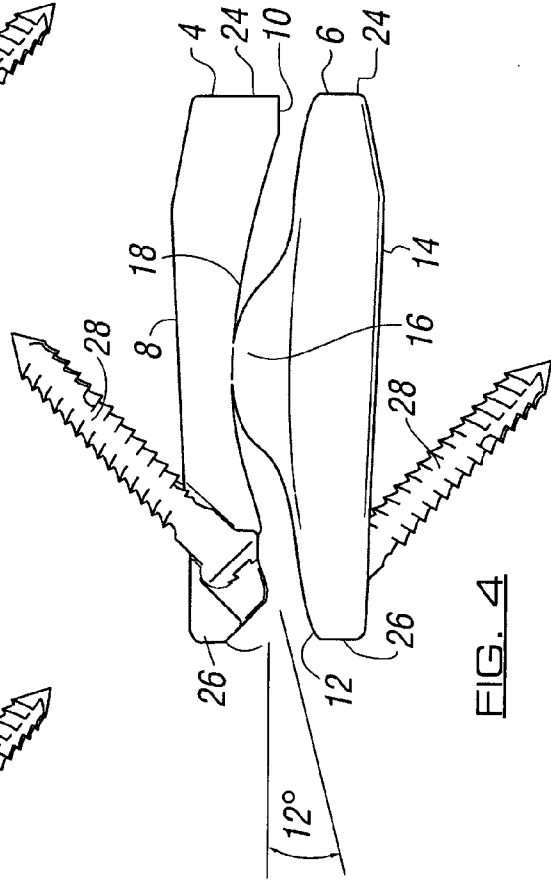
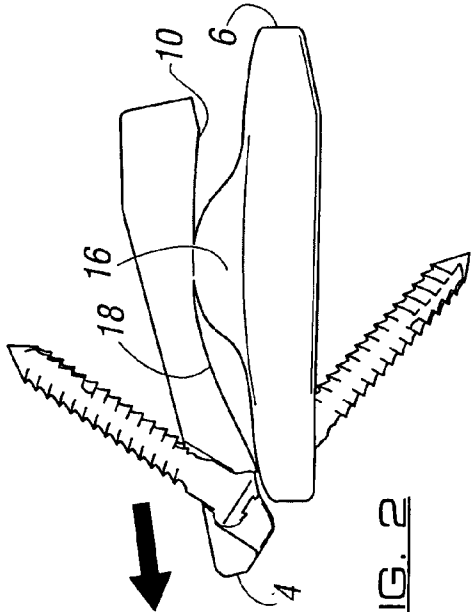
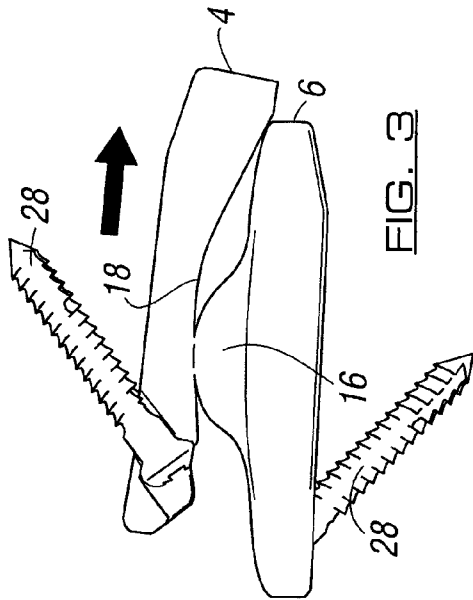

FIG. 1



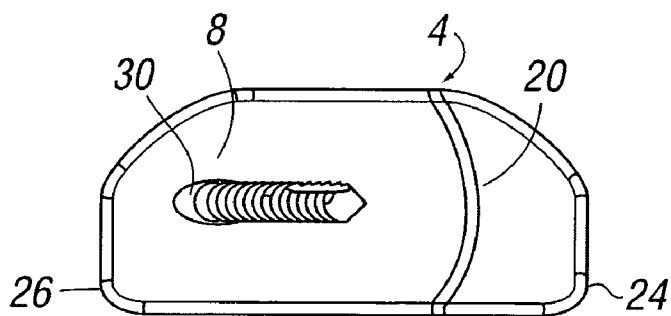

FIG. 5

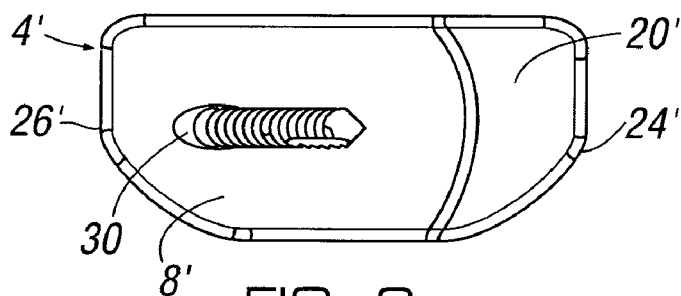

FIG. 6

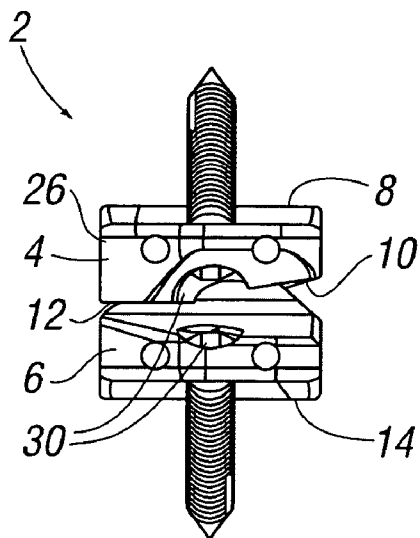

FIG. 7

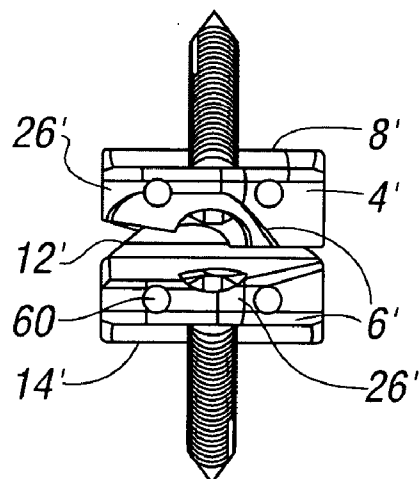

FIG. 8

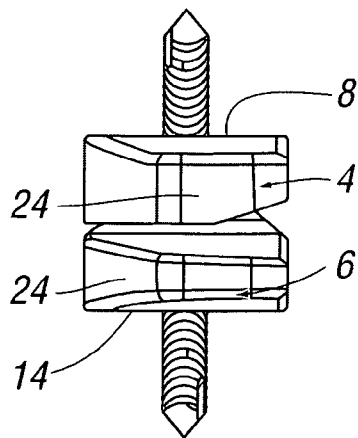

FIG. 9

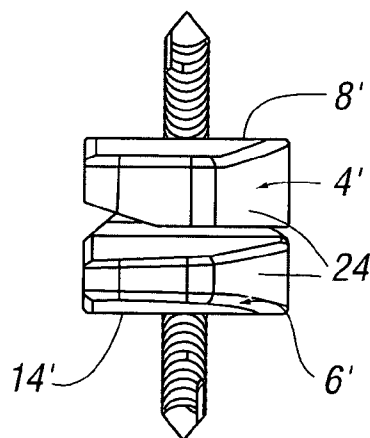

FIG. 10

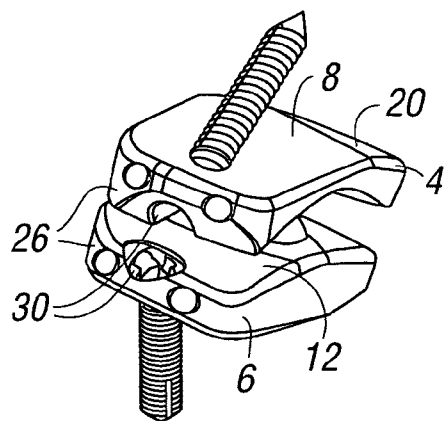

FIG. 11

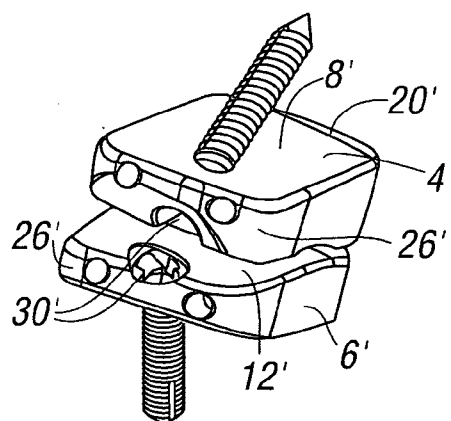

FIG. 12

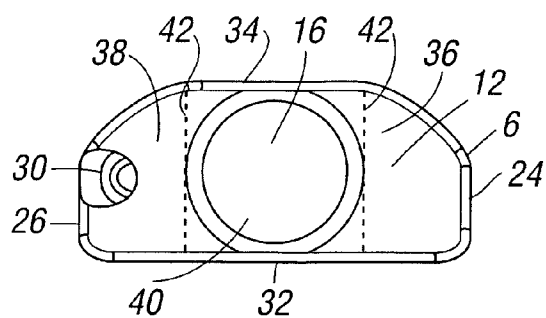

FIG. 13

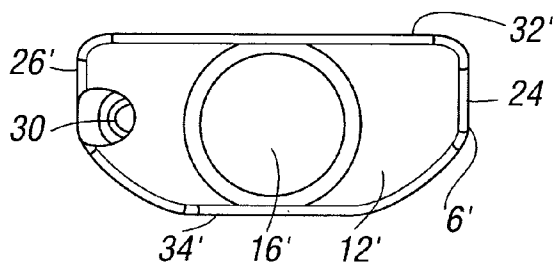

FIG. 14

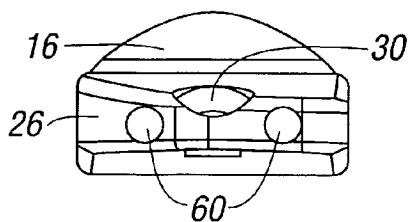

FIG. 15

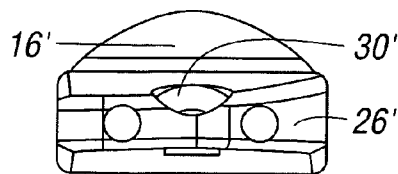

FIG. 16

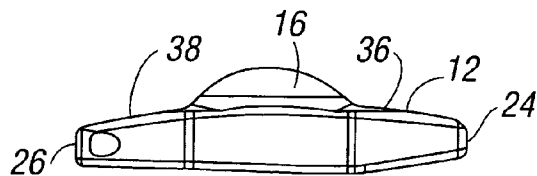

FIG. 17

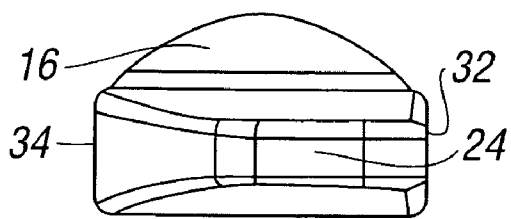

FIG. 18

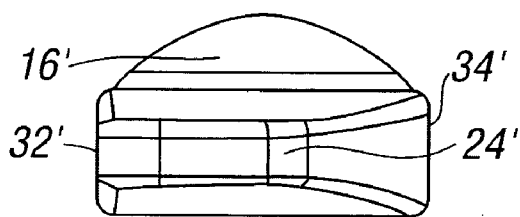

FIG. 19

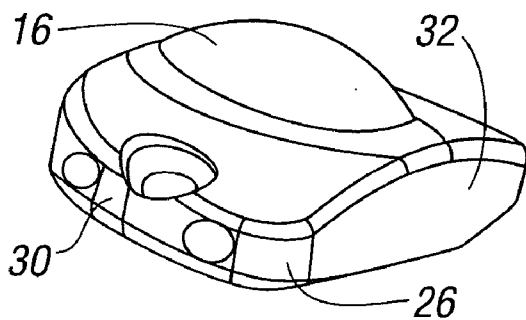

FIG. 20

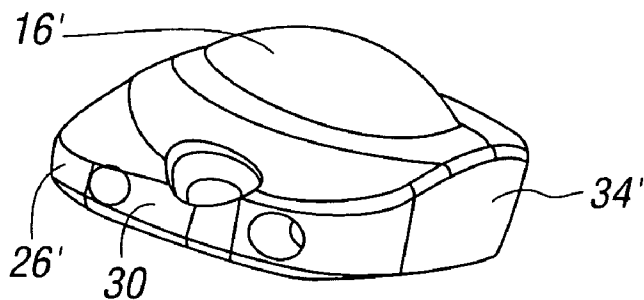

FIG. 21

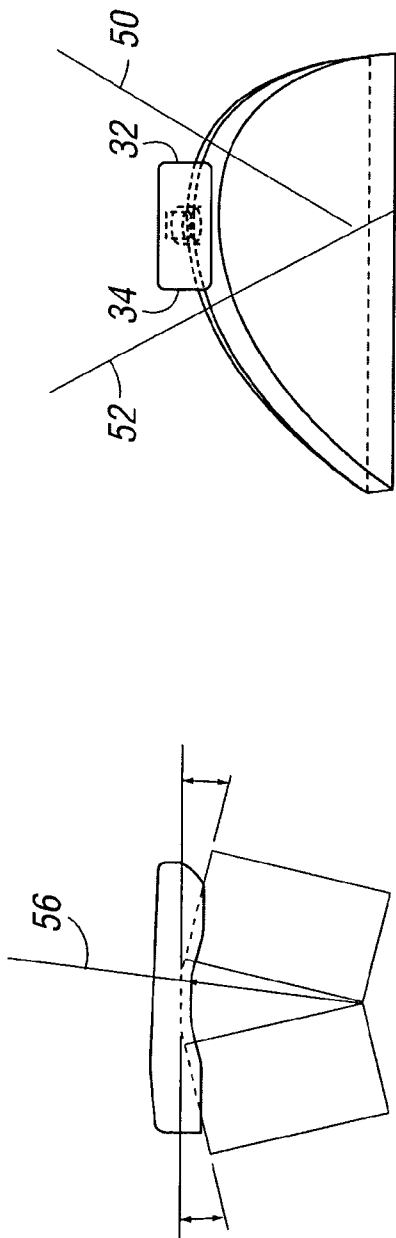

FIG. 22

FIG. 23

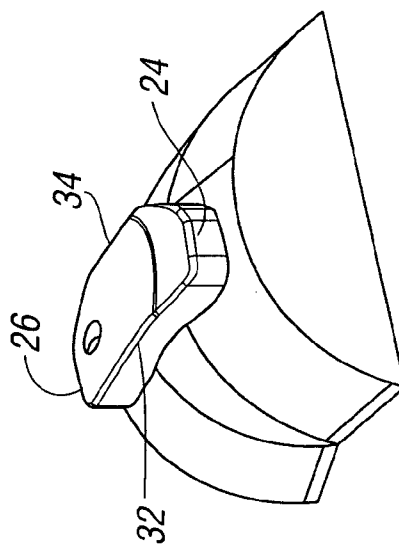

FIG. 24



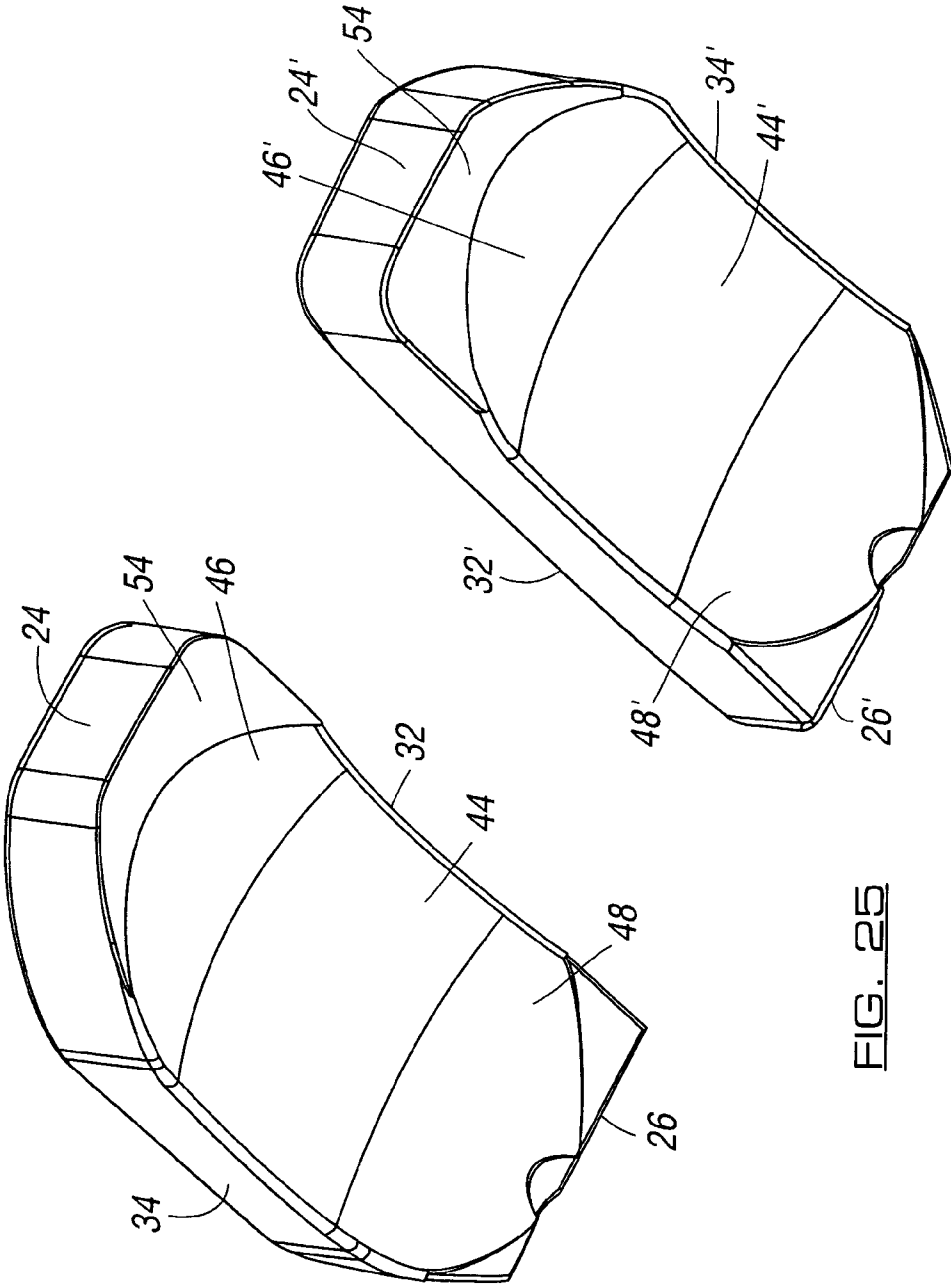

FIG. 25

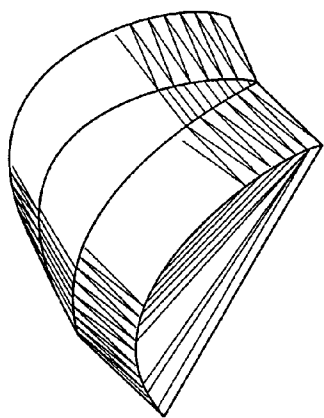

FIG. 26a

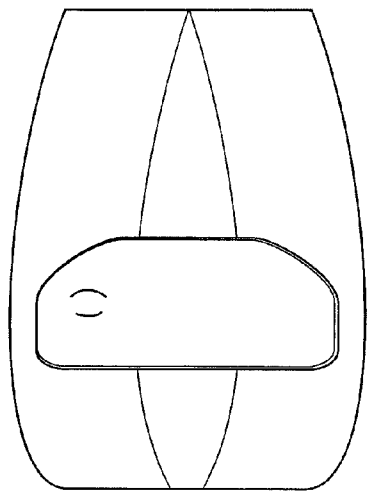

FIG. 26b

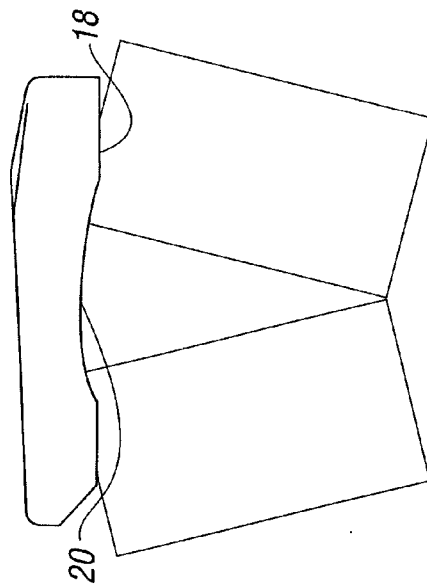

FIG. 26c

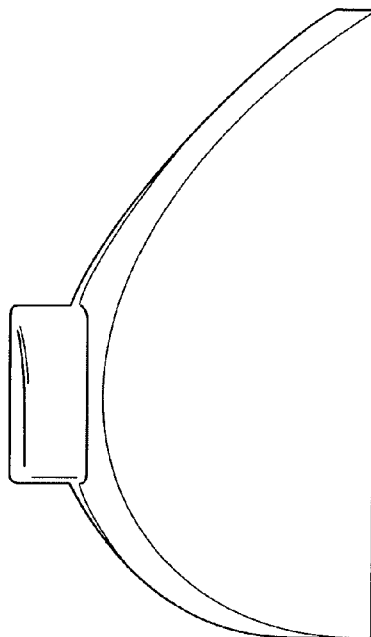

FIG. 26d

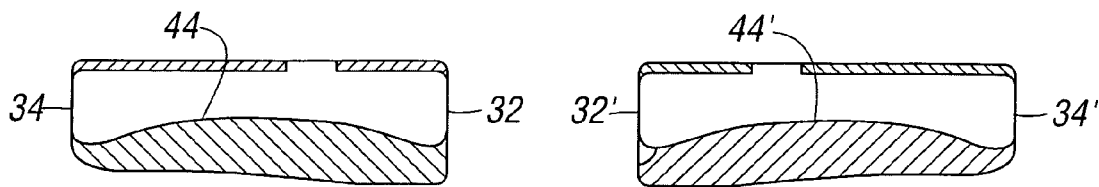

FIG. 27

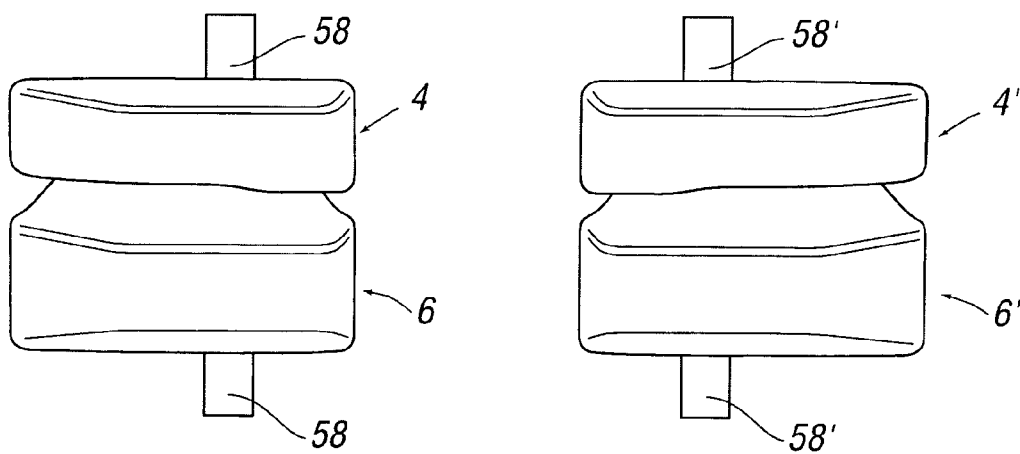

FIG. 28

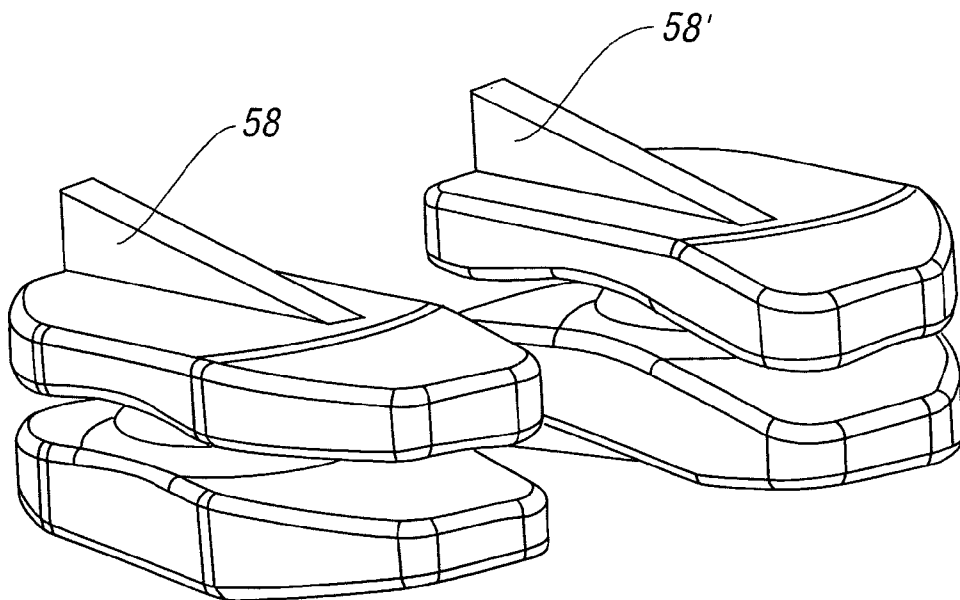

FIG. 29a

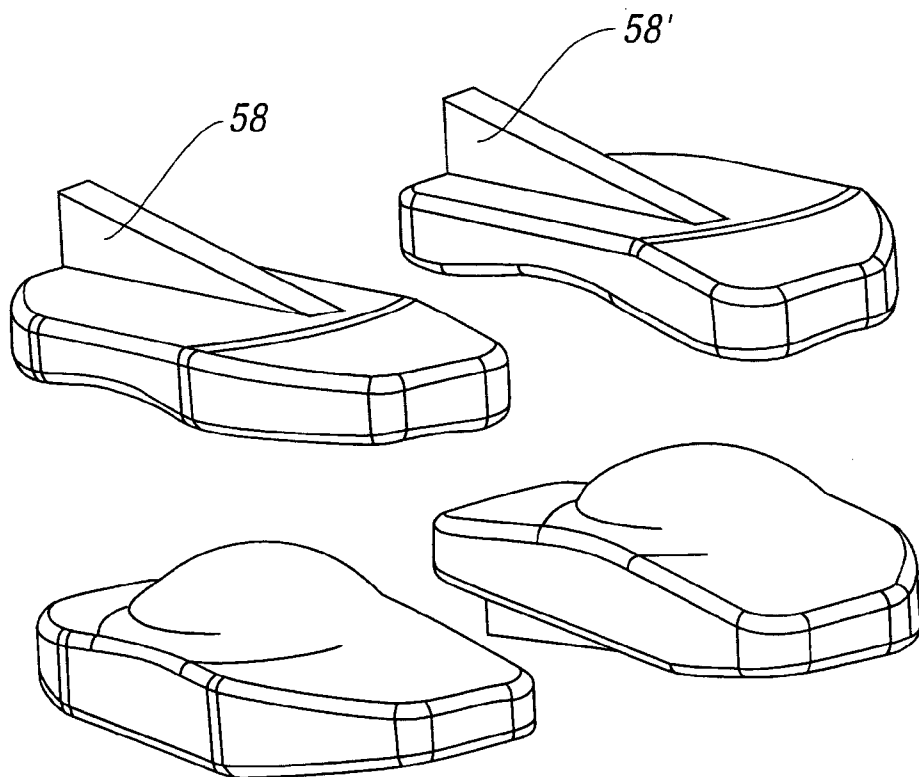

FIG. 29b

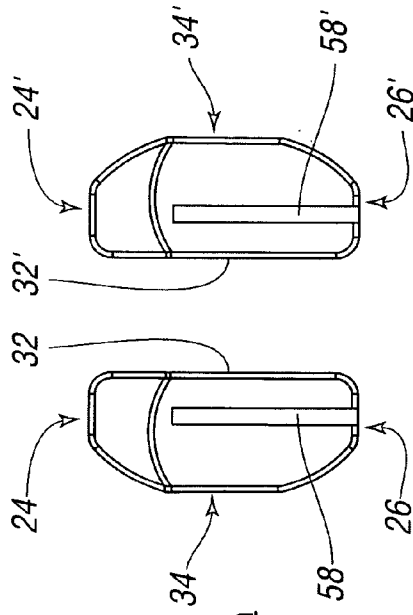

FIG. 30a

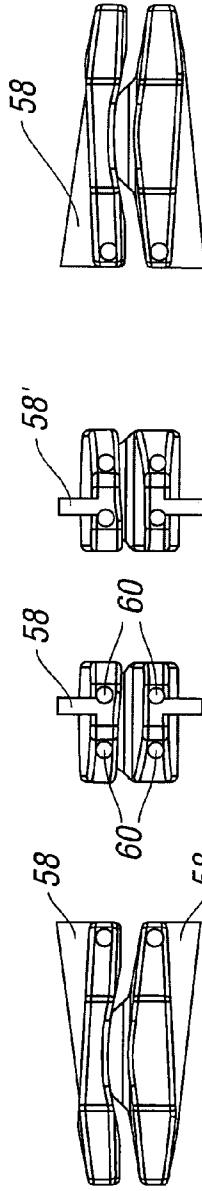

FIG. 30b

FIG. 30c

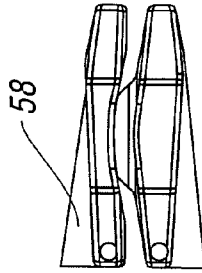

FIG. 30d

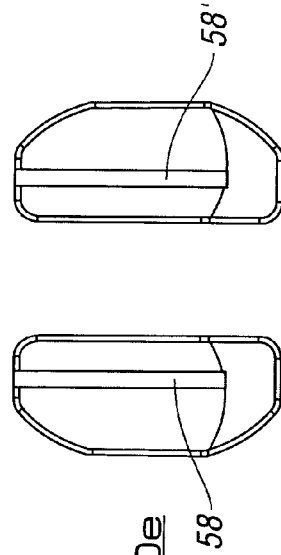

FIG. 30e

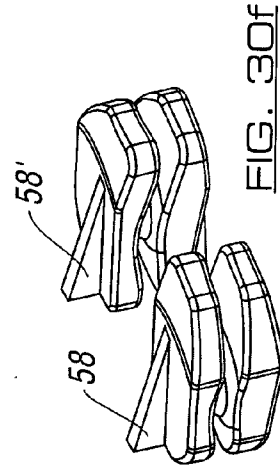

FIG. 30f

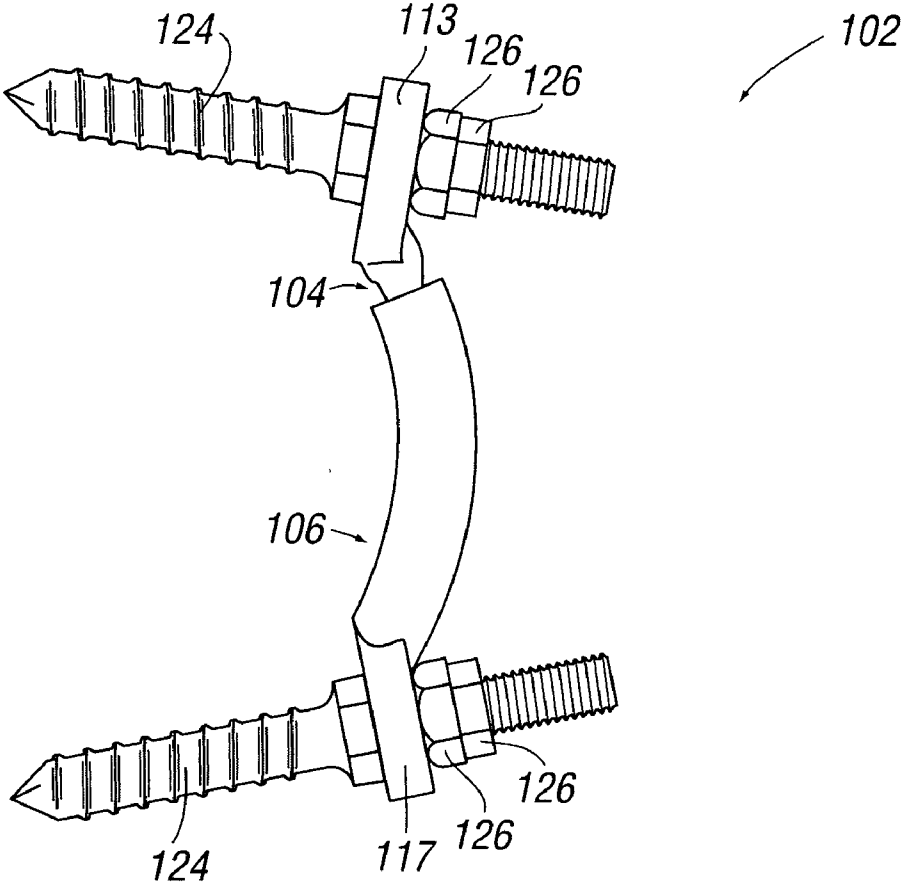

FIG. 31

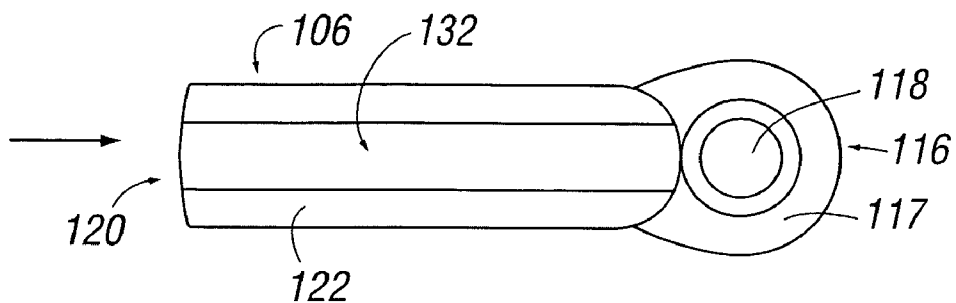

FIG. 32

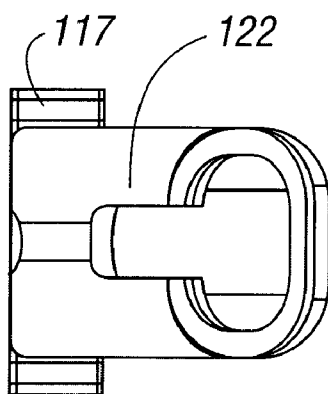

FIG. 33

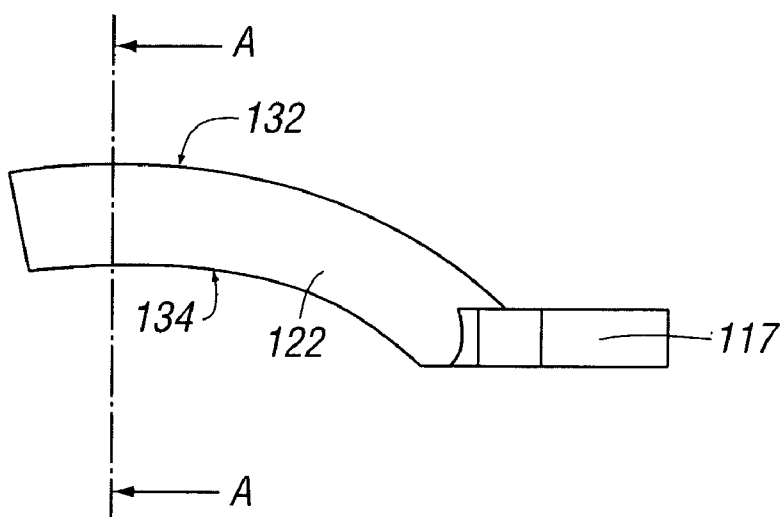

FIG. 34

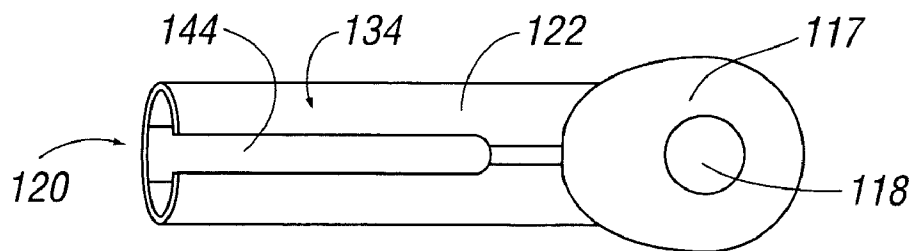

FIG. 35

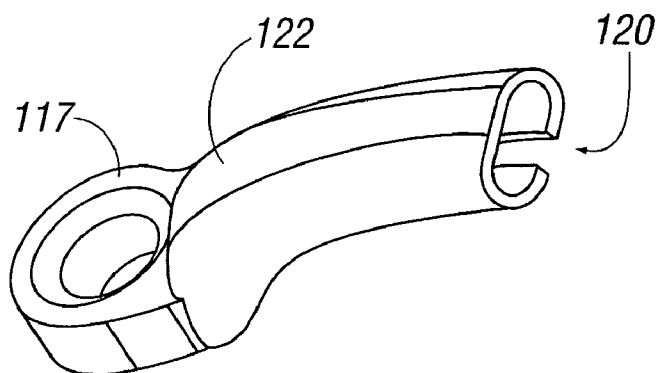

FIG. 36

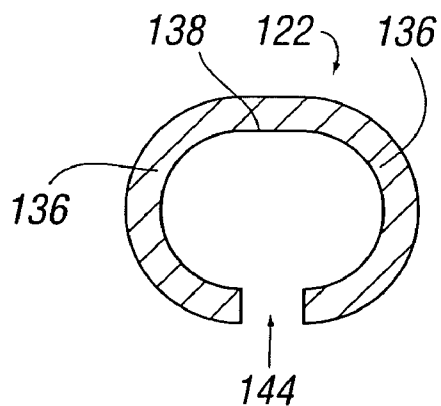

FIG. 37



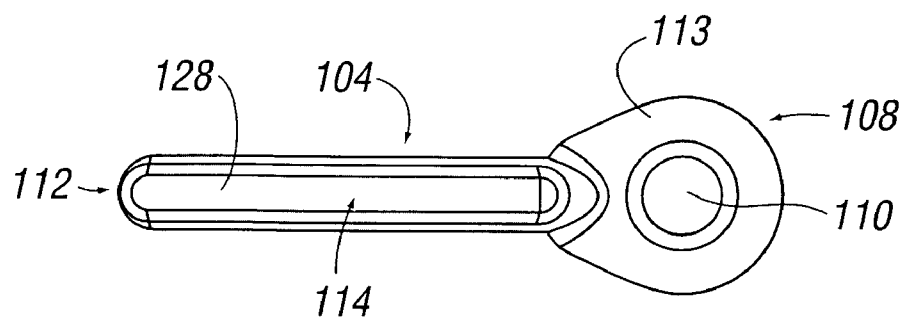

FIG. 38

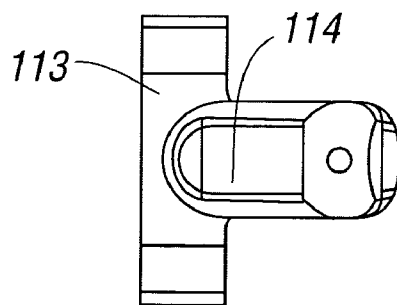

FIG. 39

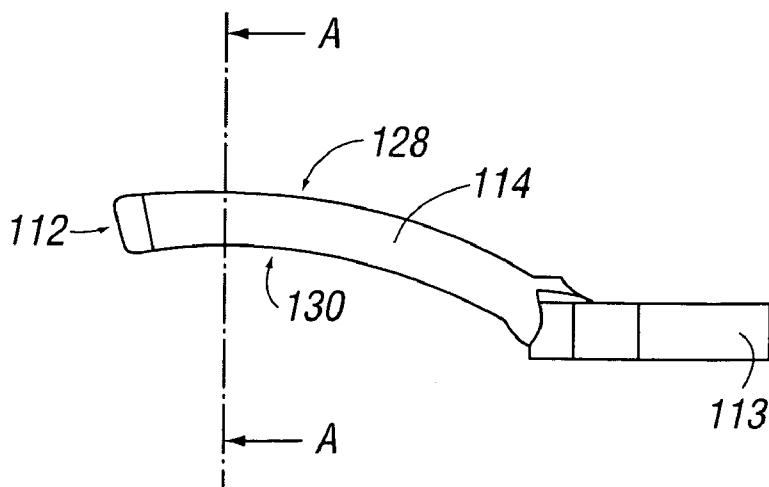

FIG. 40

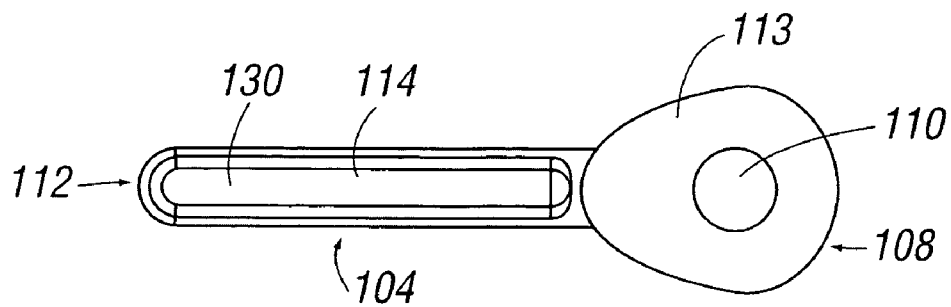

FIG. 41

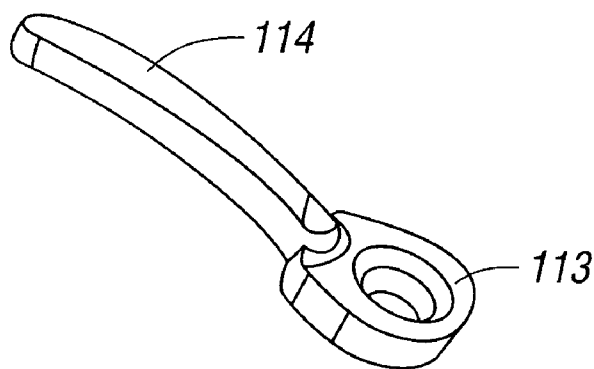

FIG. 42

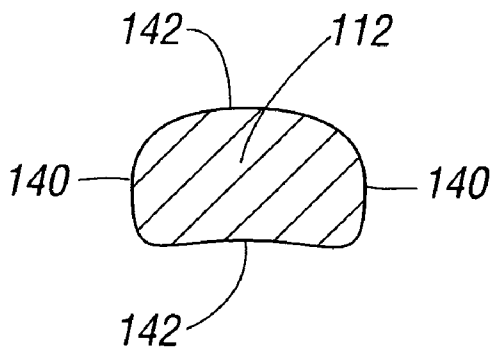

FIG. 43

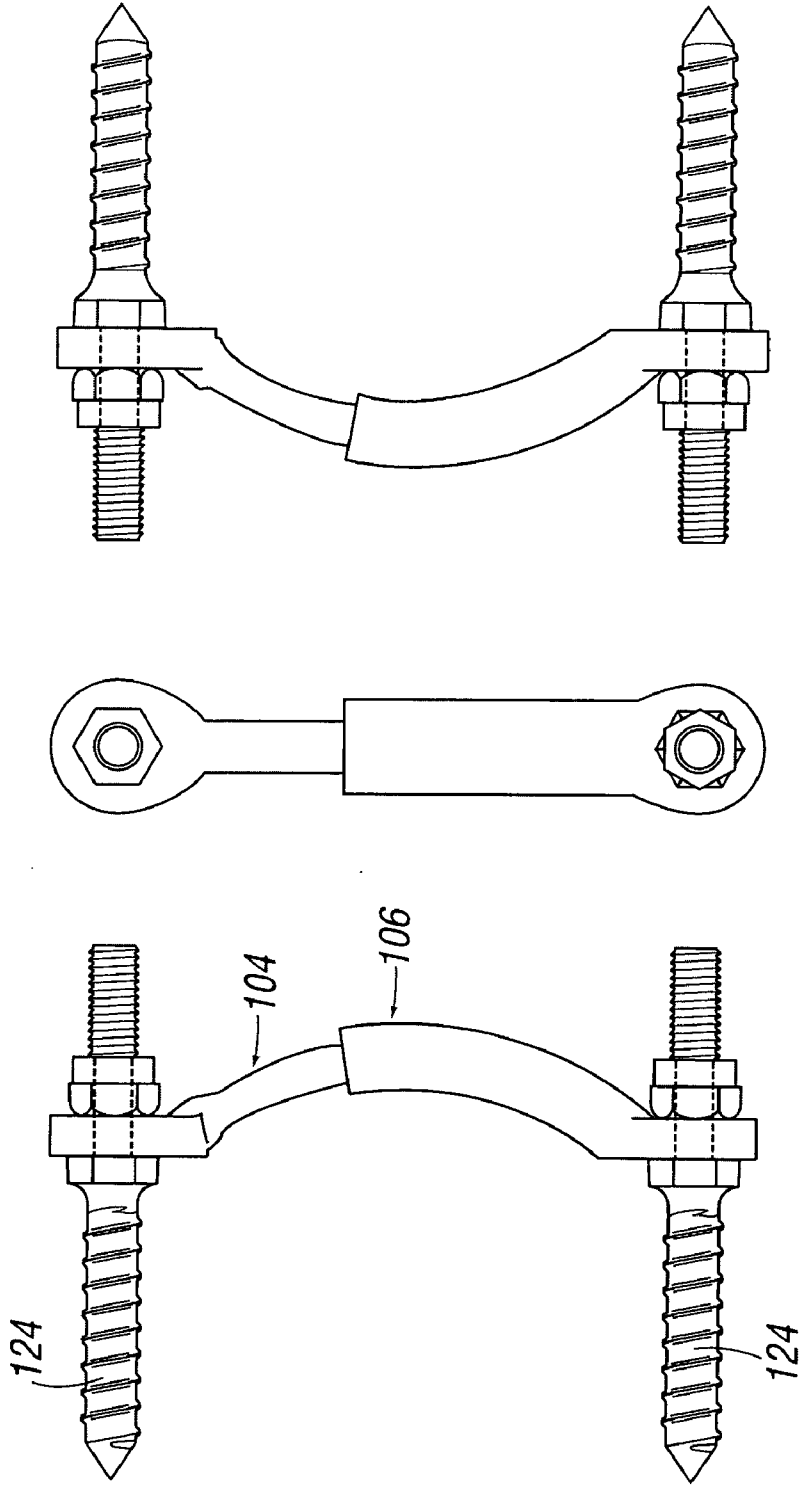

FIG. 44b

FIG. 44a

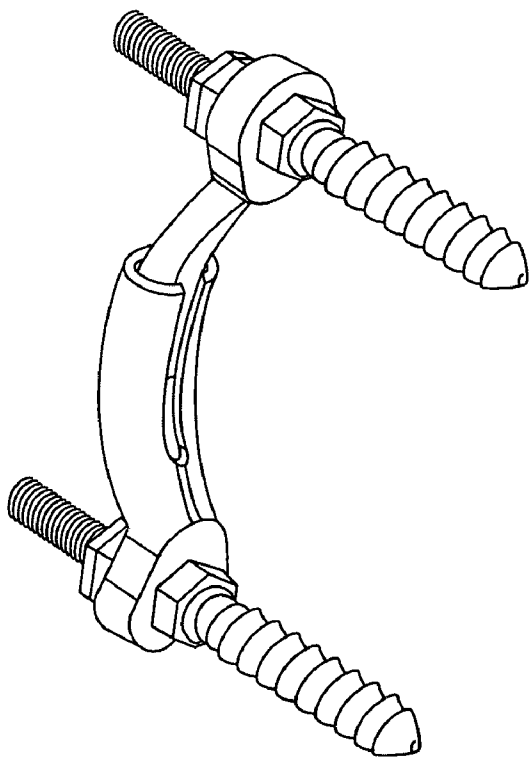

FIG. 44c

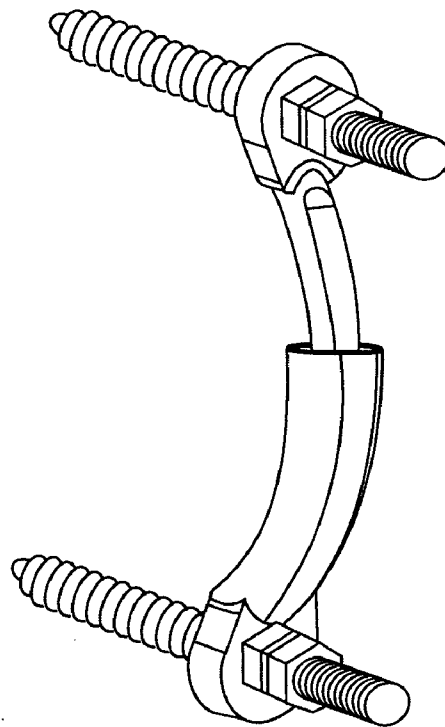

FIG. 44d

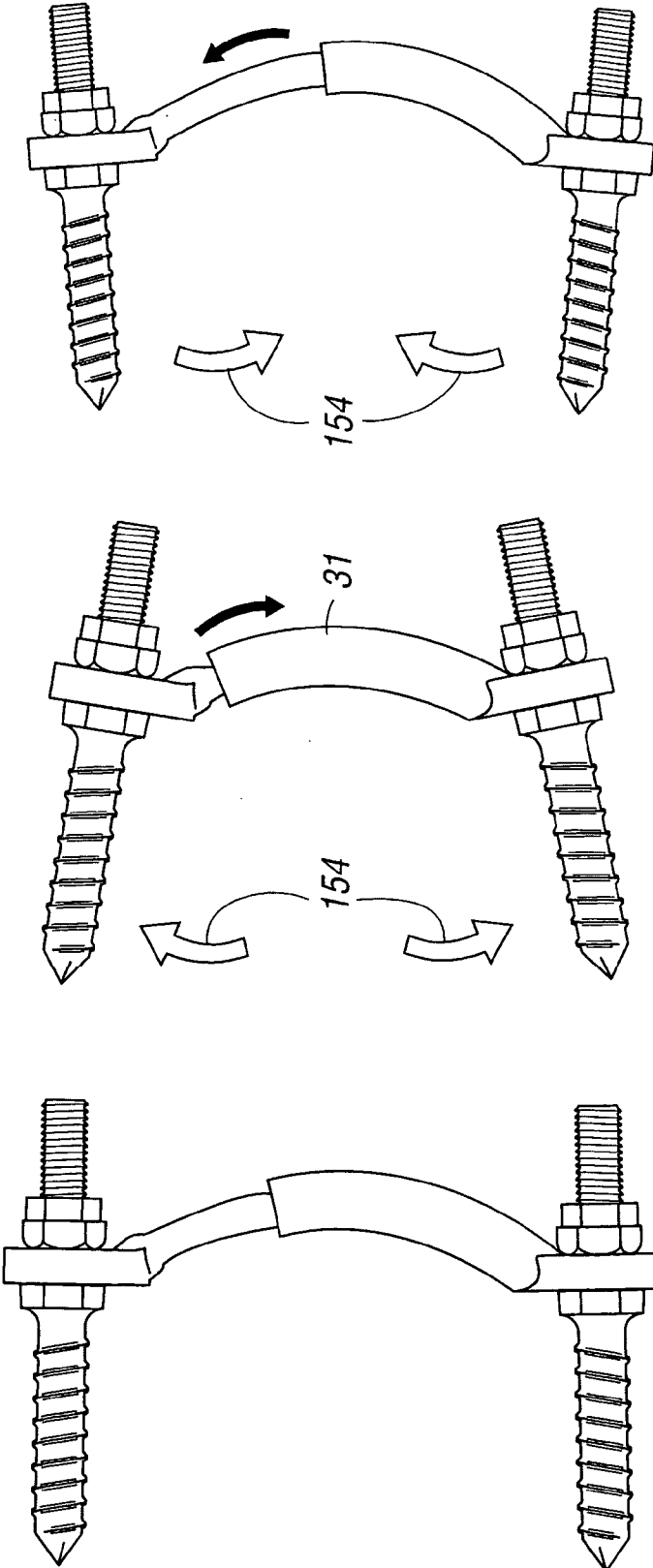

FIG. 45b

FIG. 45a

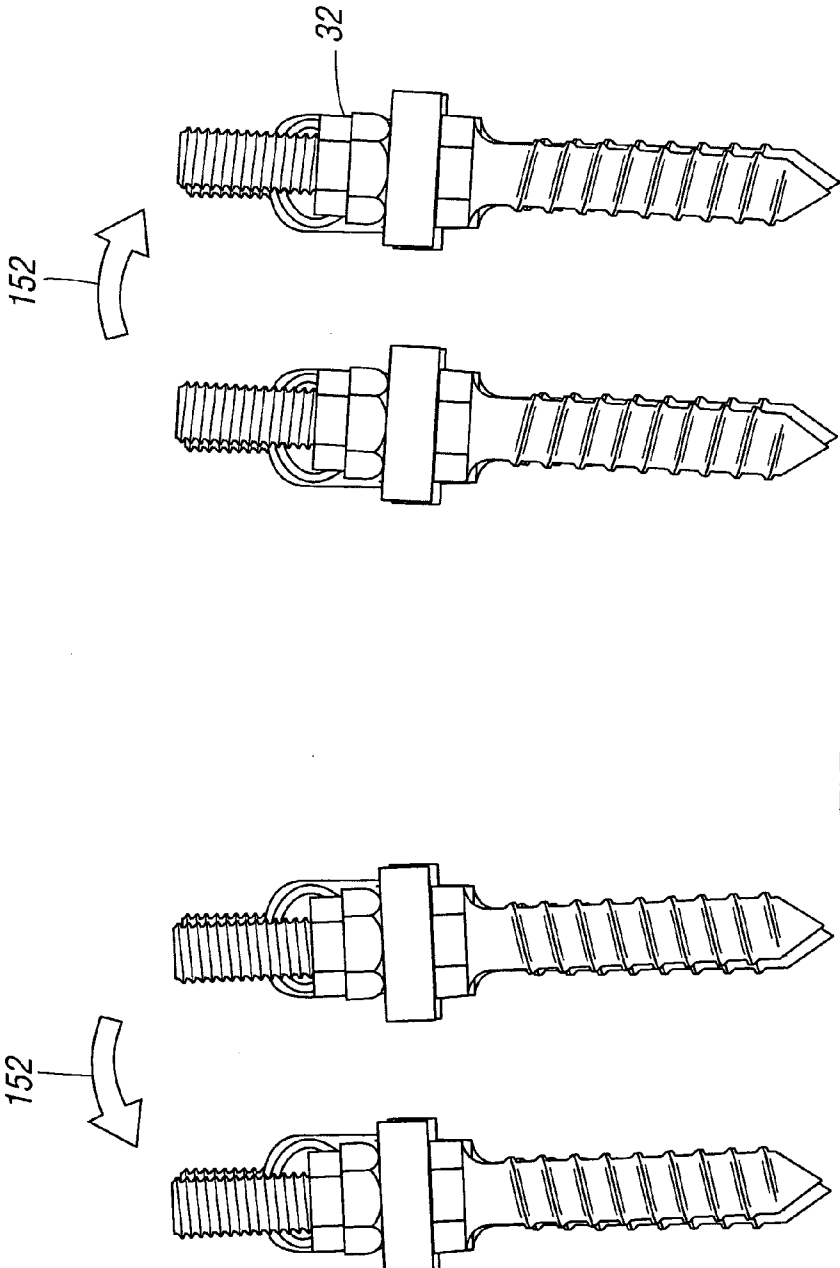

FIG. 46

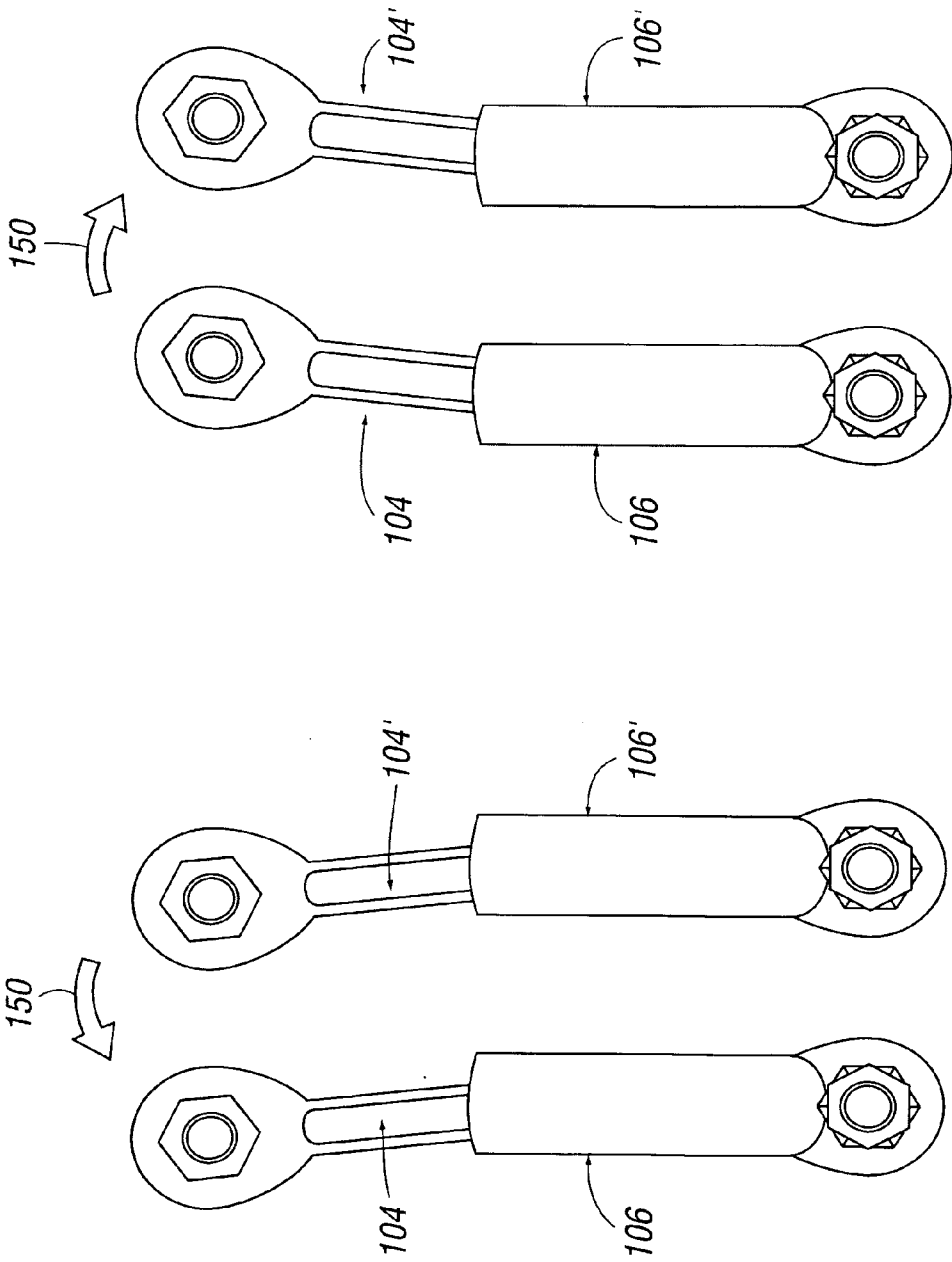

FIG. 47

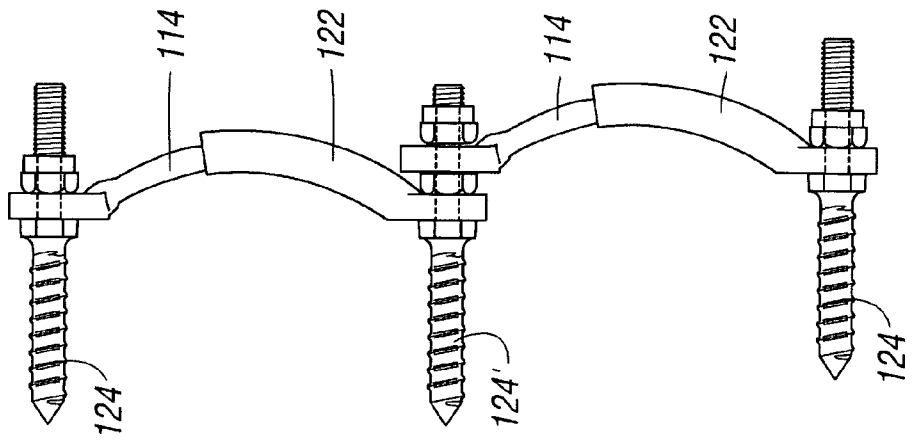
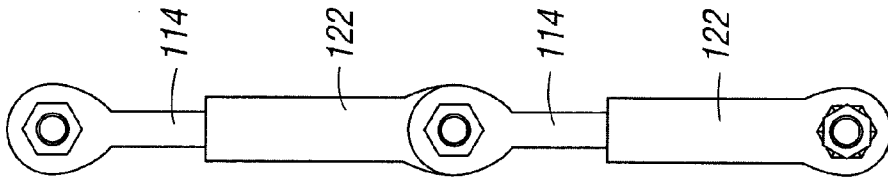
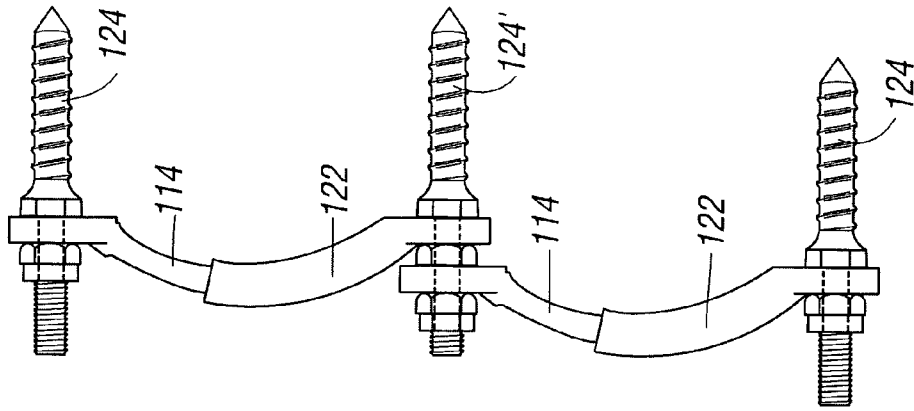

FIG. 48b

FIG. 48a



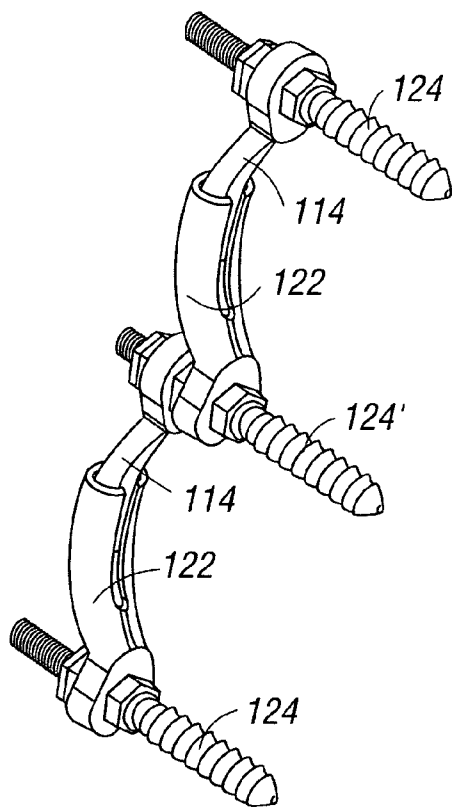

FIG. 48c

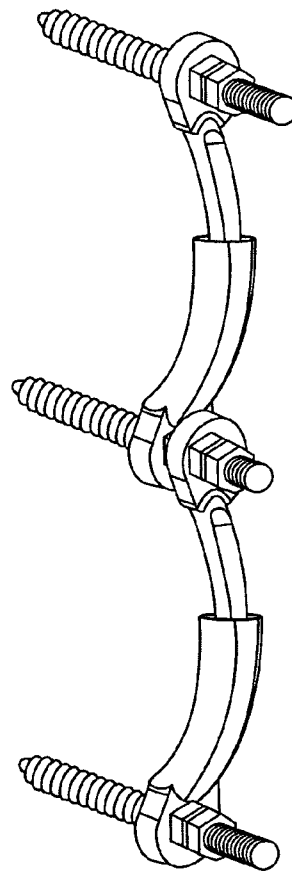

FIG. 48d

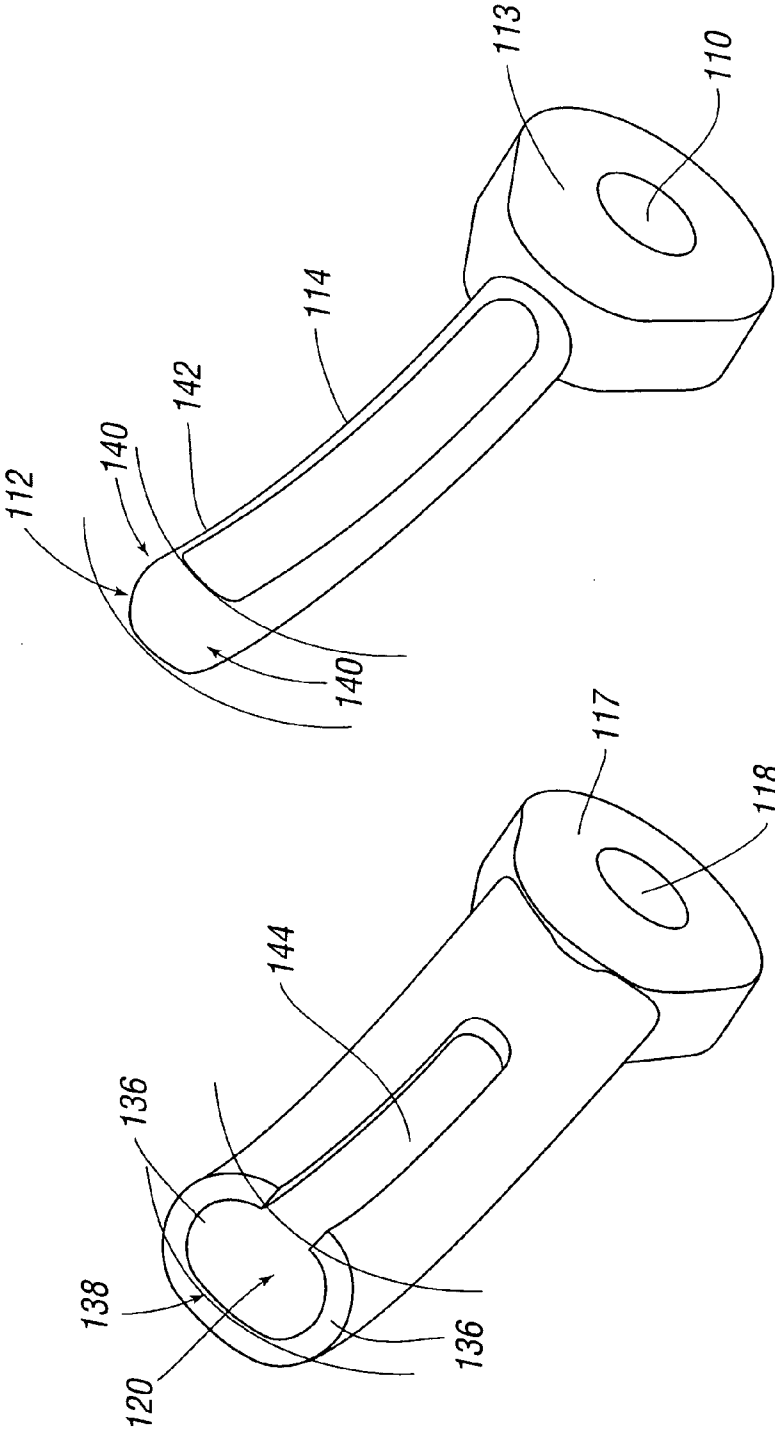

FIG. 49

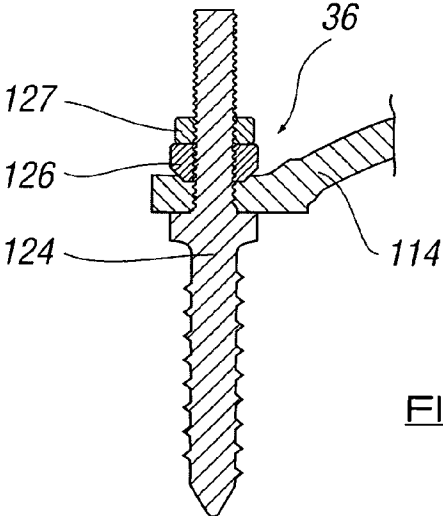

FIG. 50

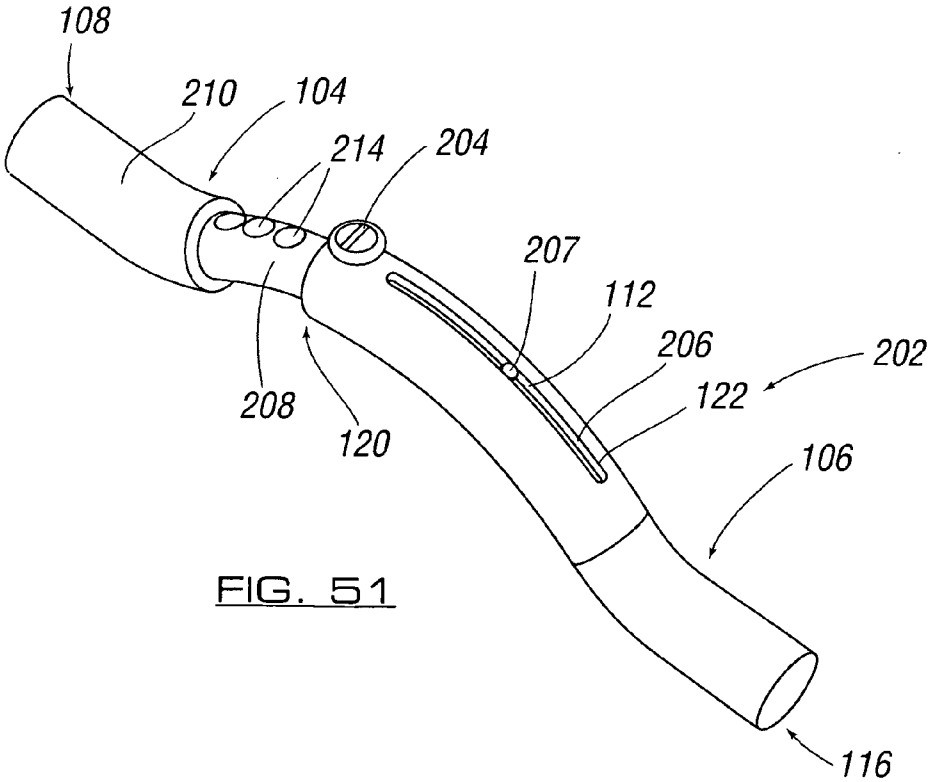
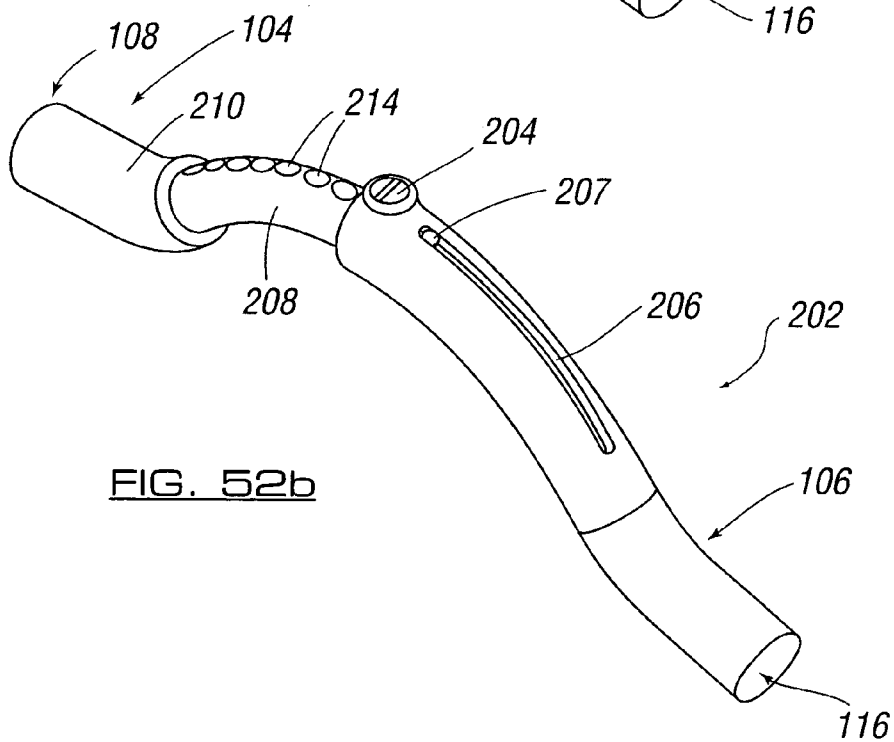
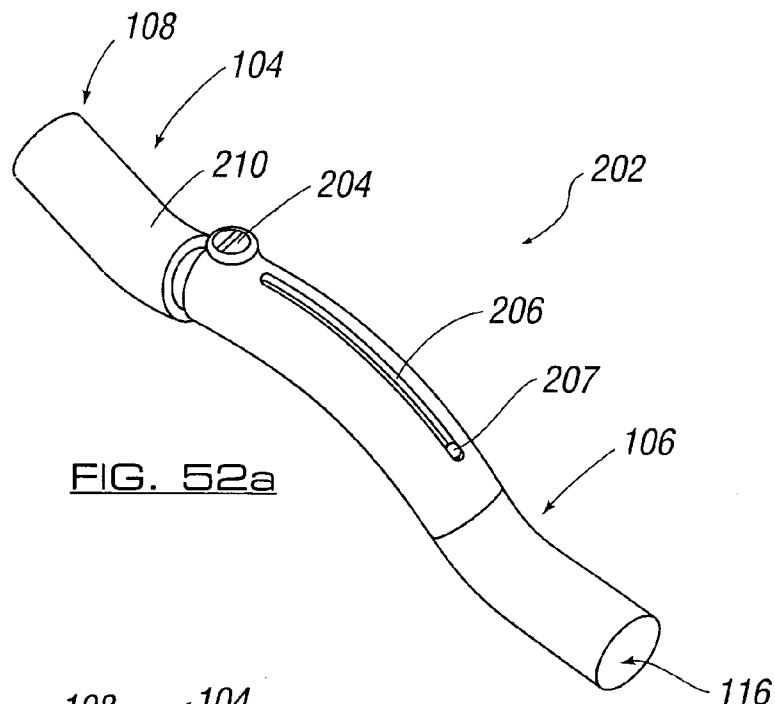

FIG. 51



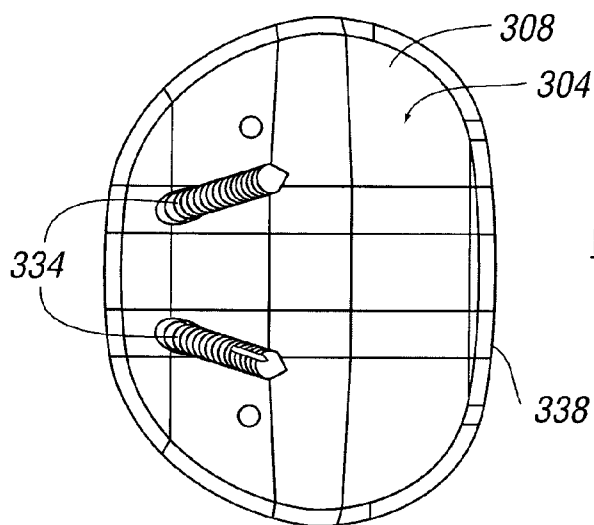

FIG. 53a

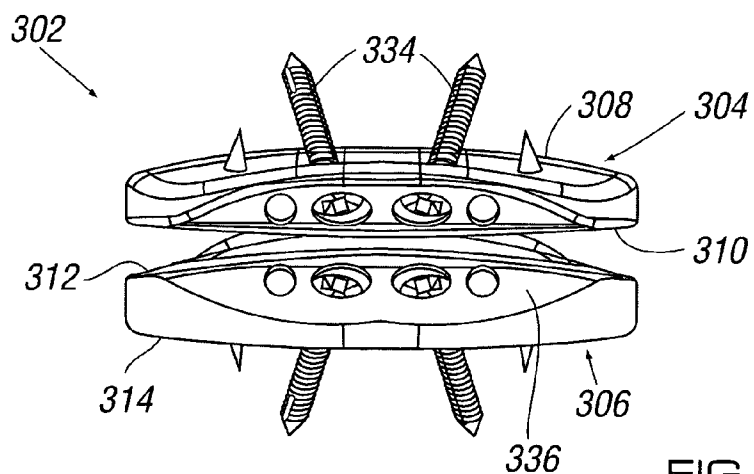

FIG. 53b

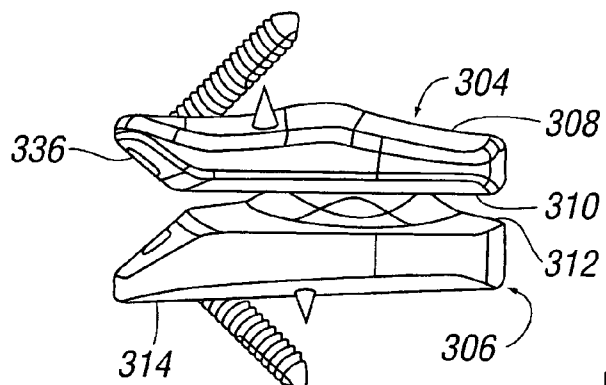

FIG. 53c

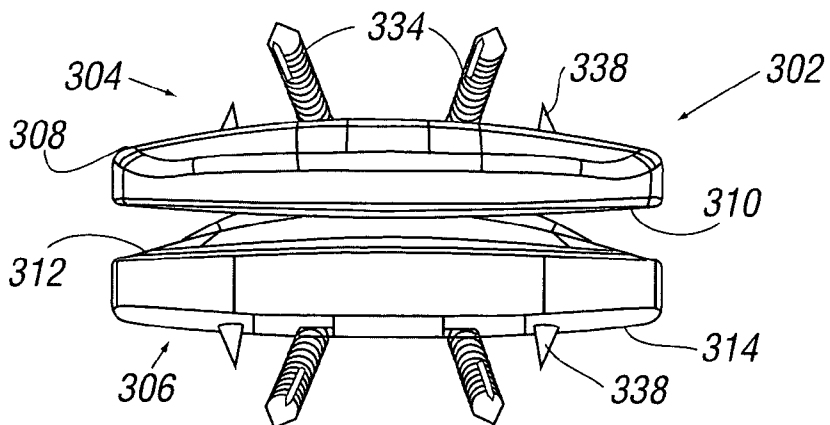

FIG. 53d

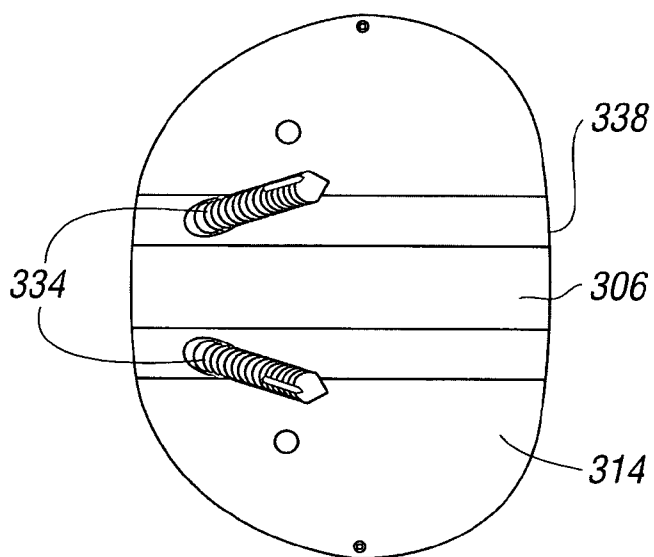

FIG. 53e

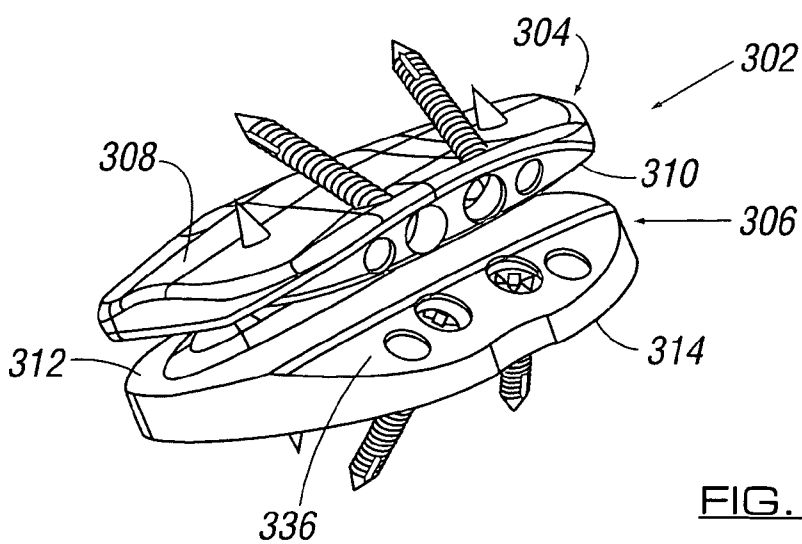
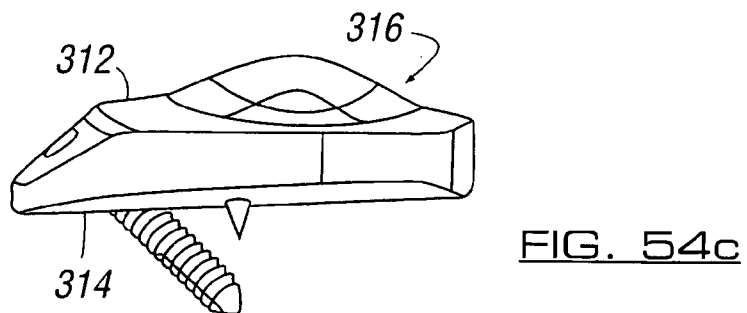
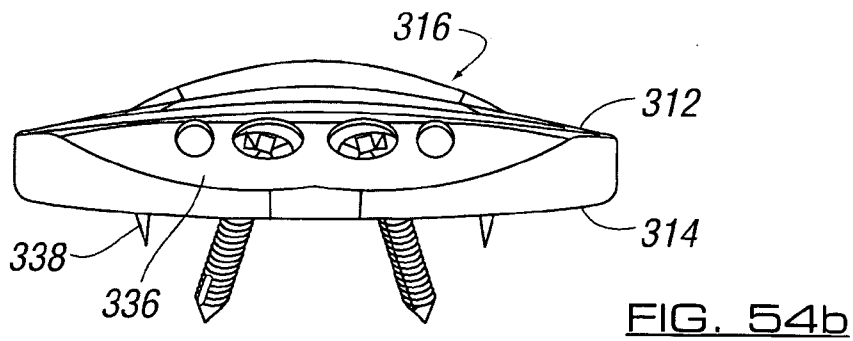
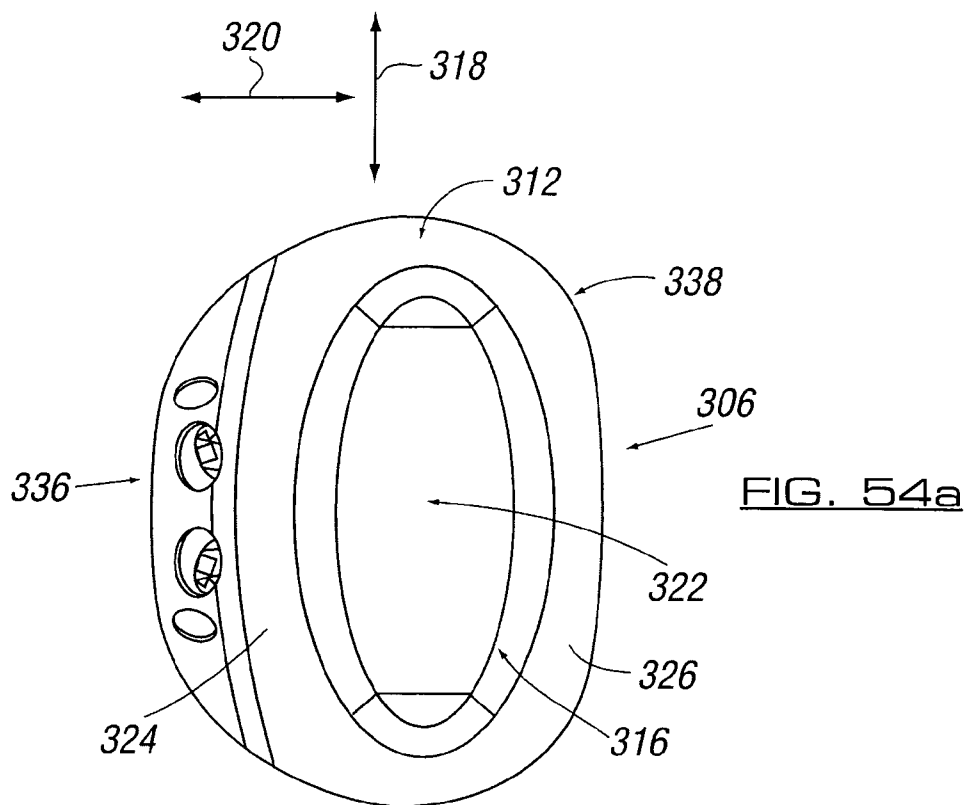

FIG. 53f



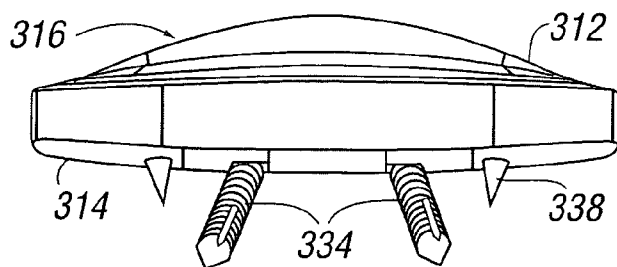

FIG. 54d

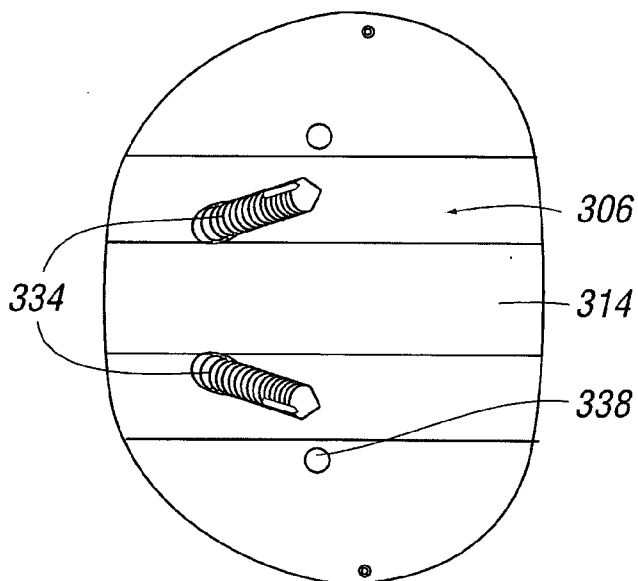

FIG. 54e

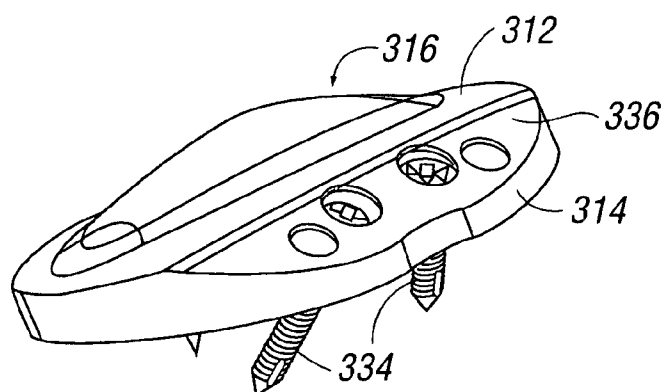

FIG. 54f



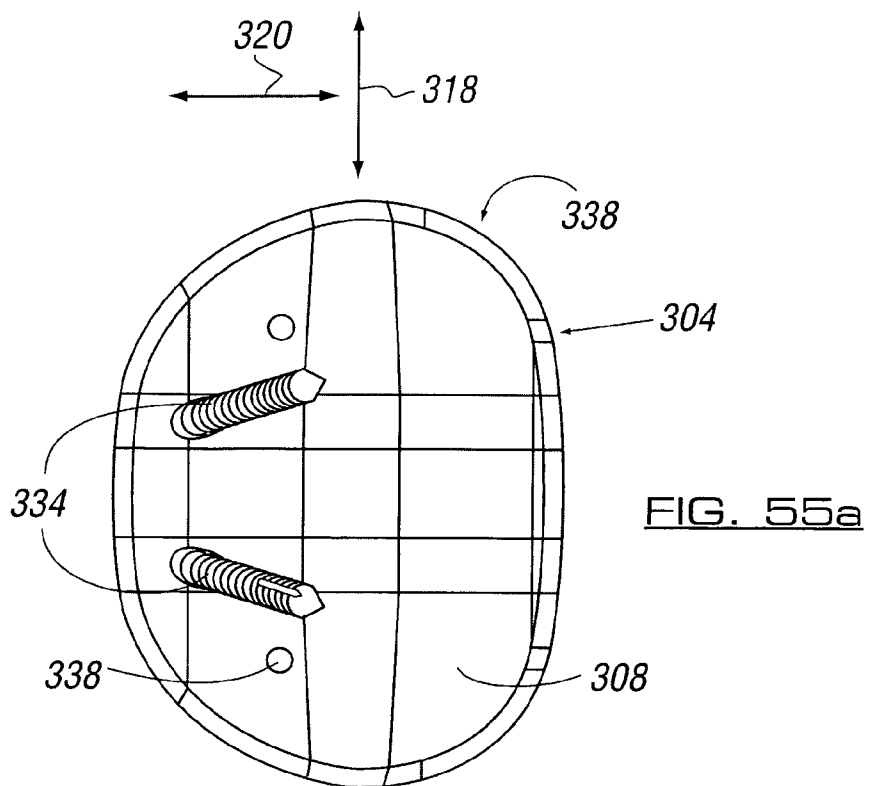

FIG. 55a

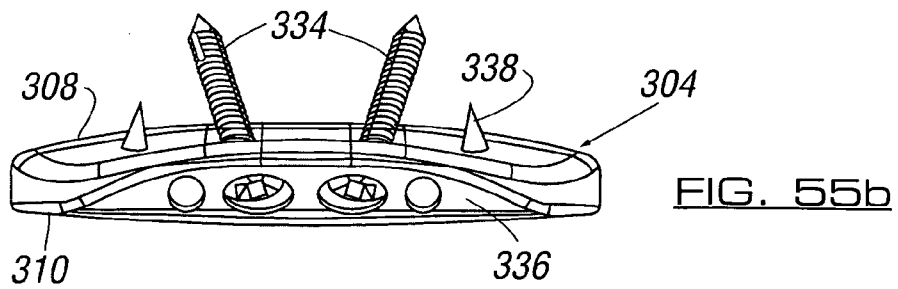

FIG. 55b

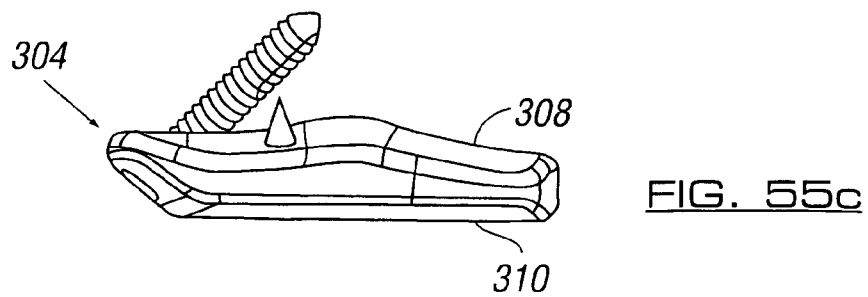

FIG. 55c

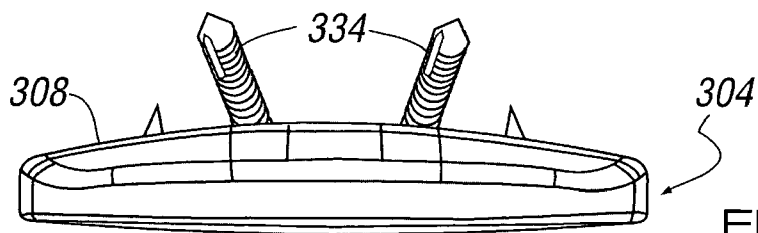

FIG. 55d

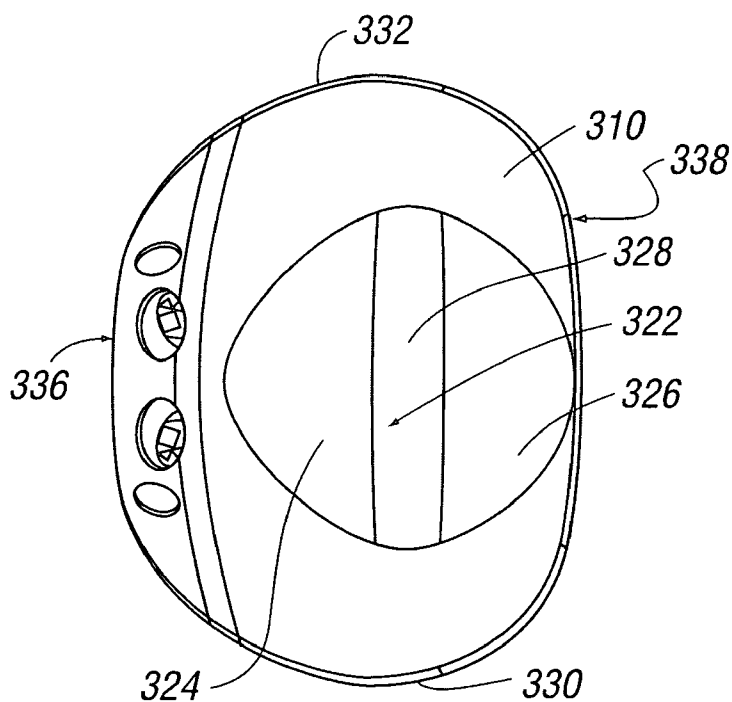

FIG. 55e

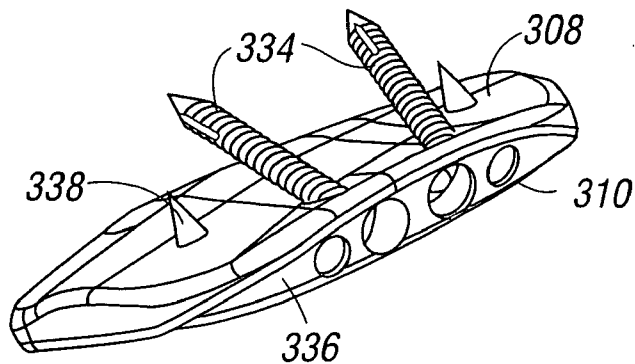
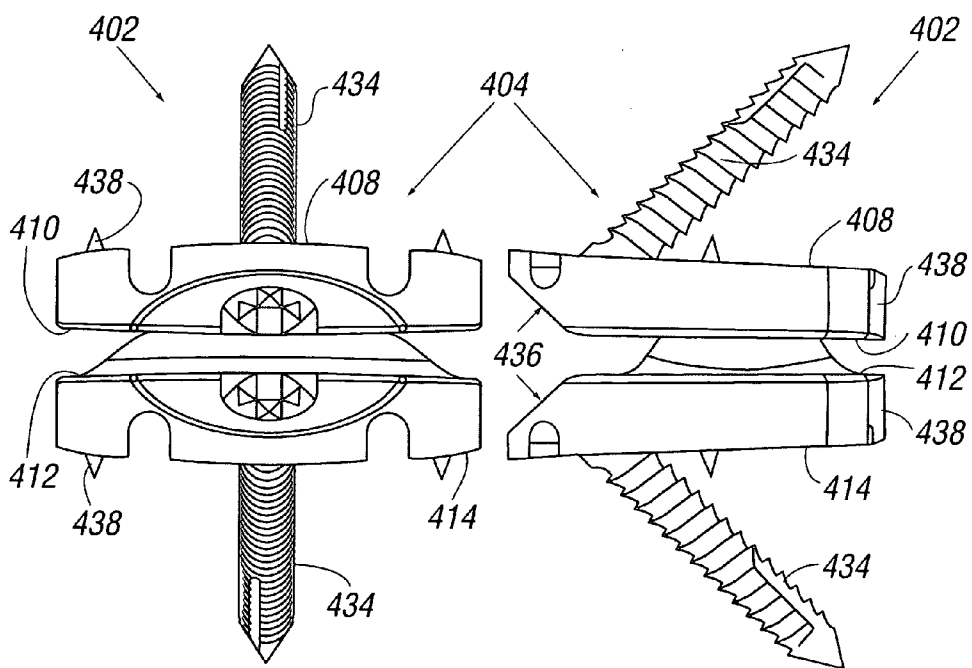
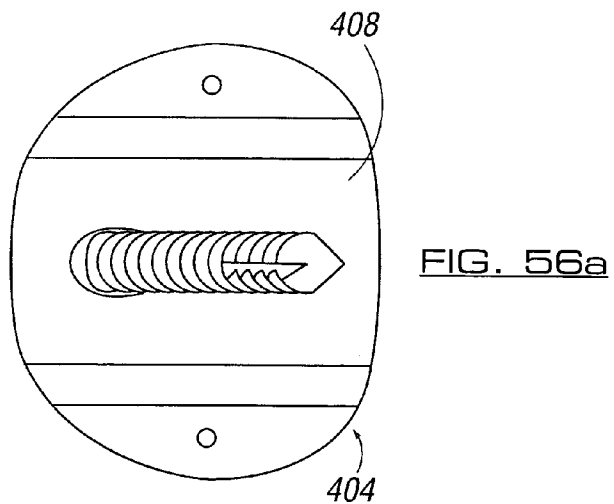

FIG. 55f



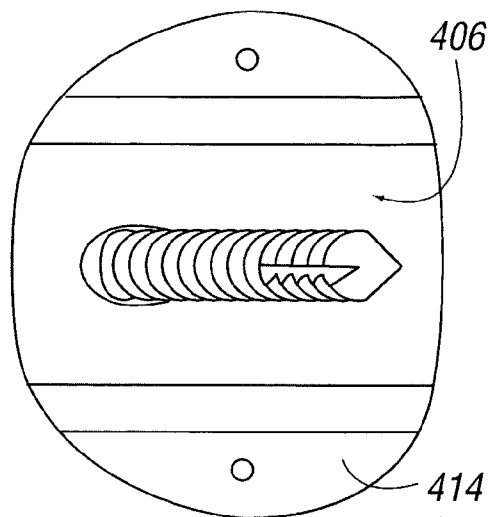

FIG. 56d

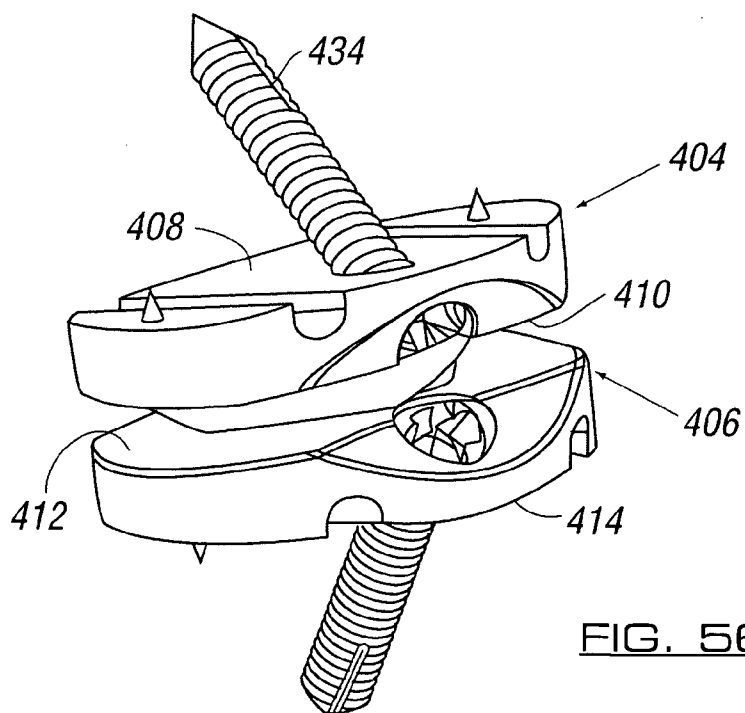

FIG. 56e

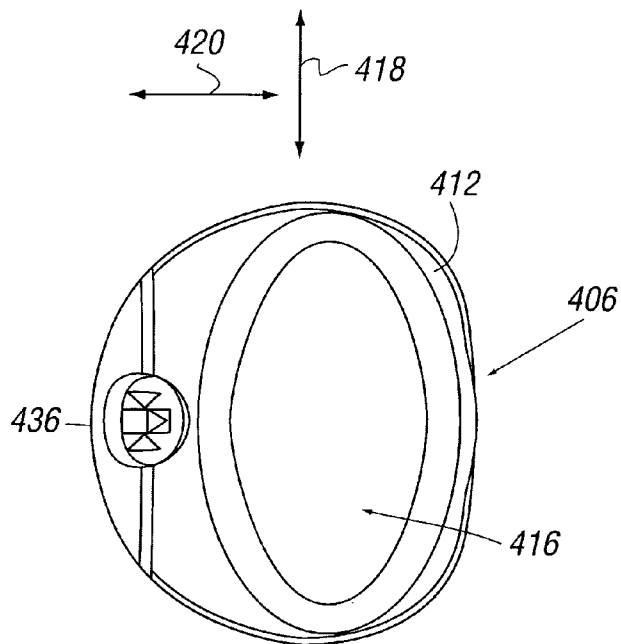

FIG. 57a

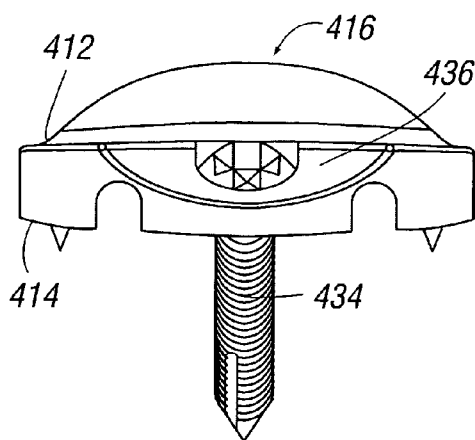

FIG. 57b

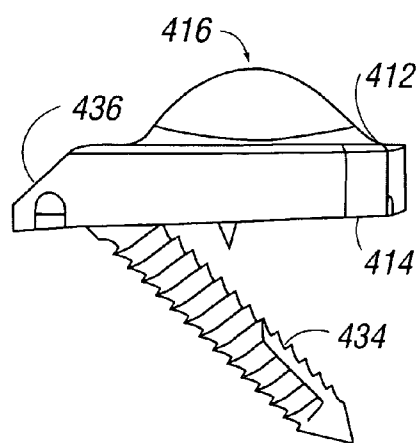

FIG. 57c

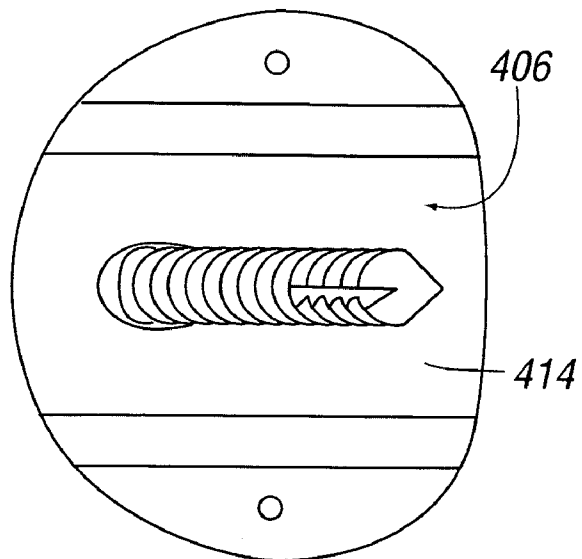

FIG. 57d

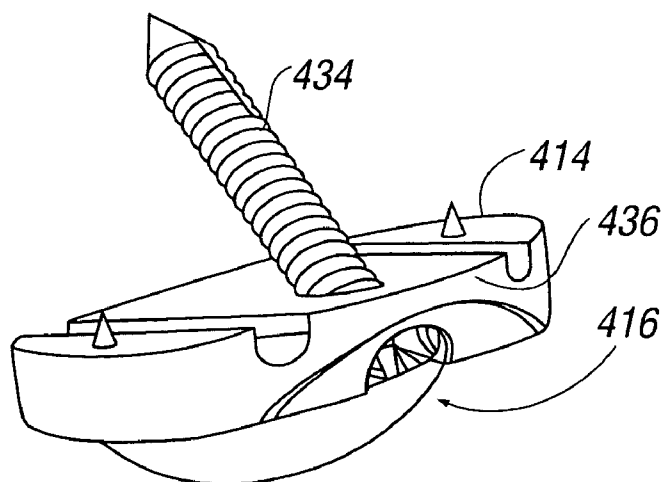

FIG. 57e

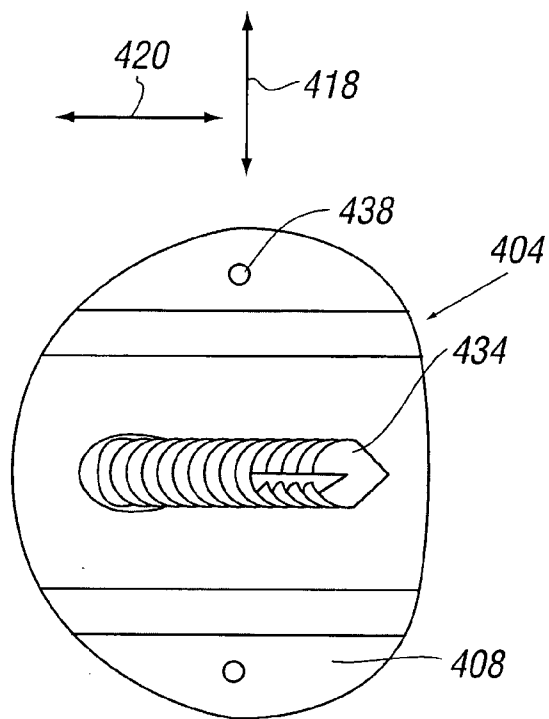

FIG. 58a

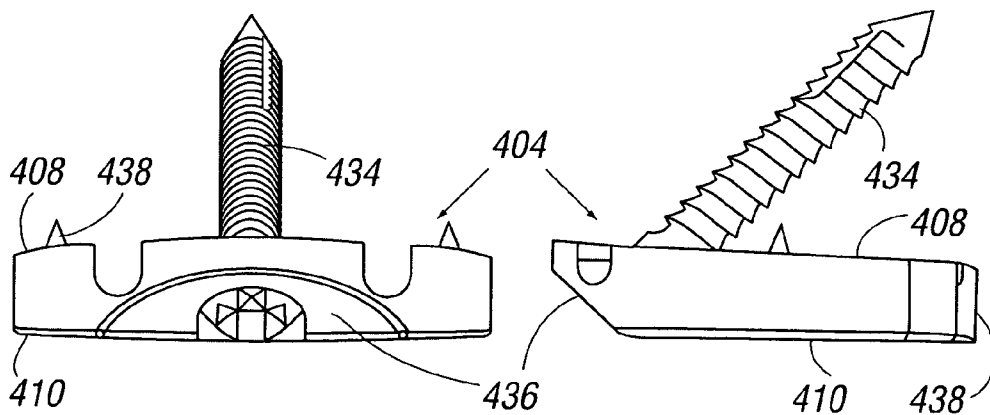

FIG. 58b

FIG. 58c

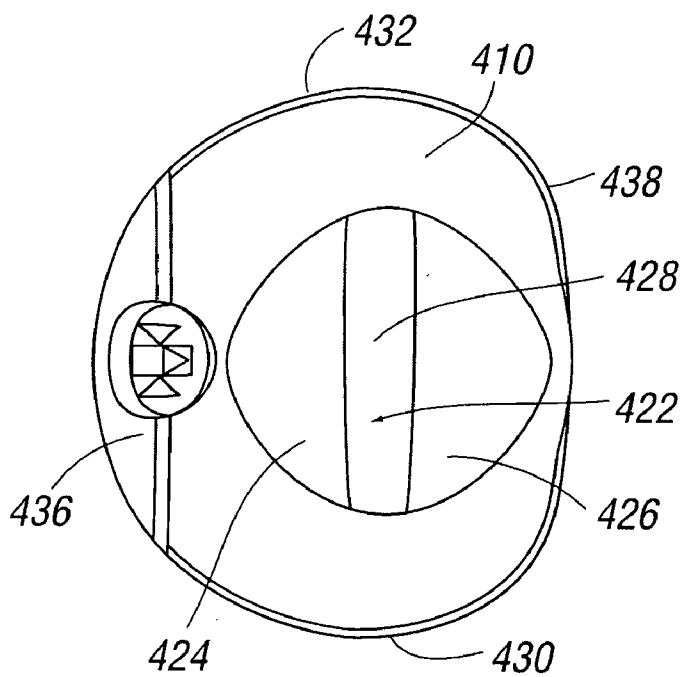

FIG. 58d

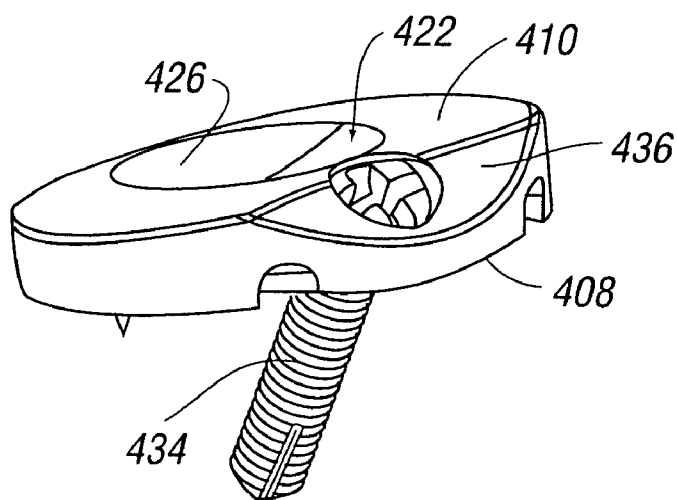

FIG. 58e



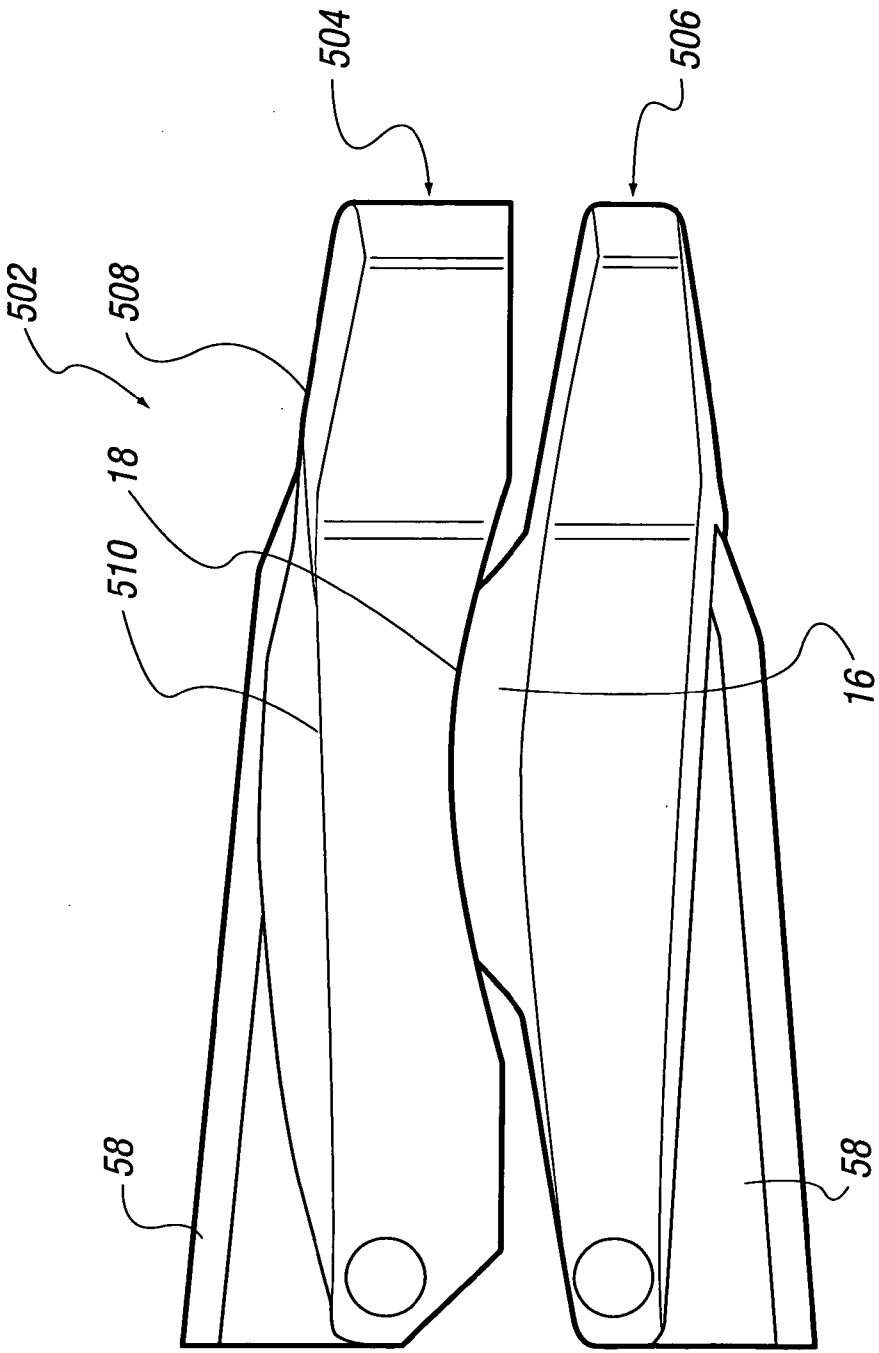

FIG. 59a

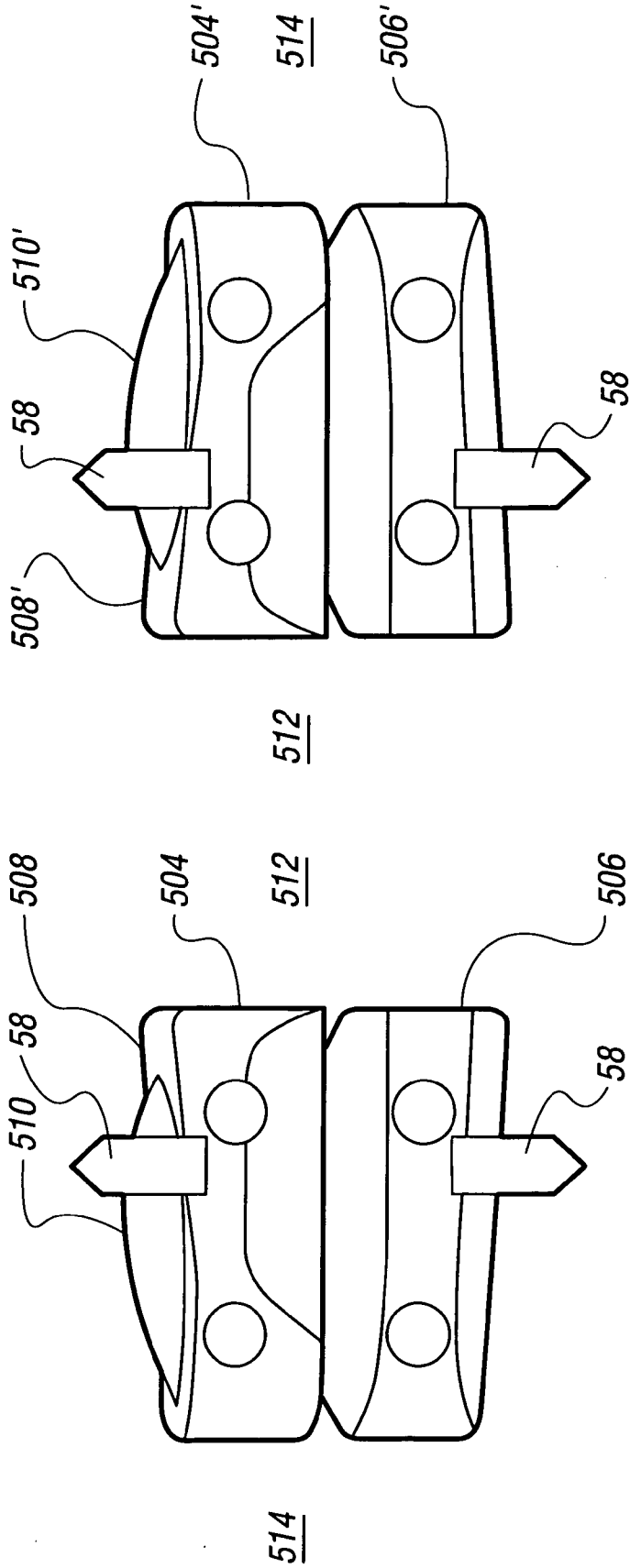

FIG. 59b

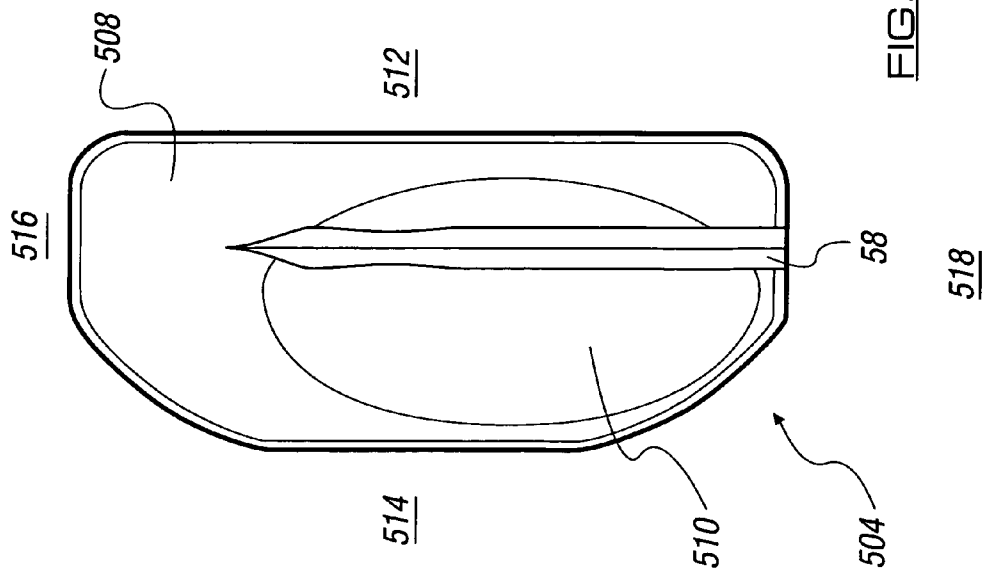
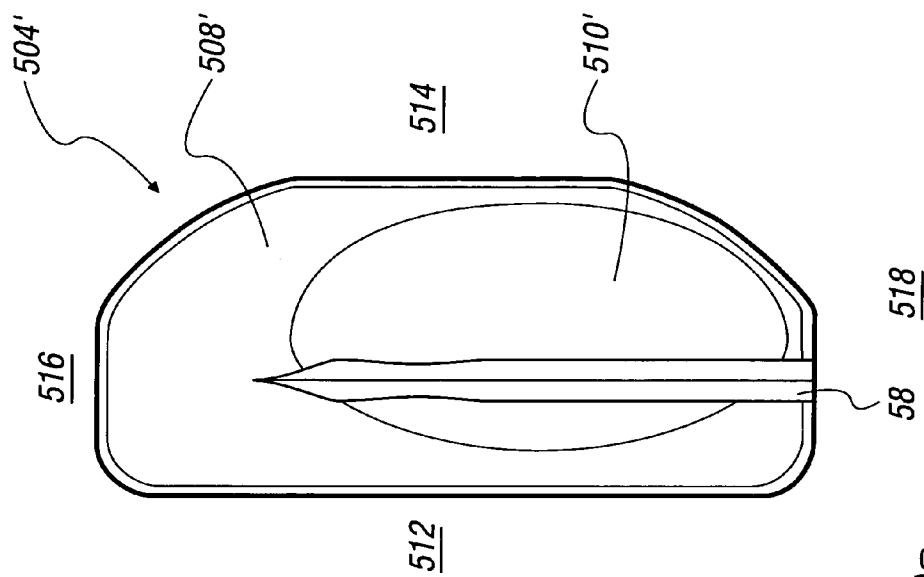
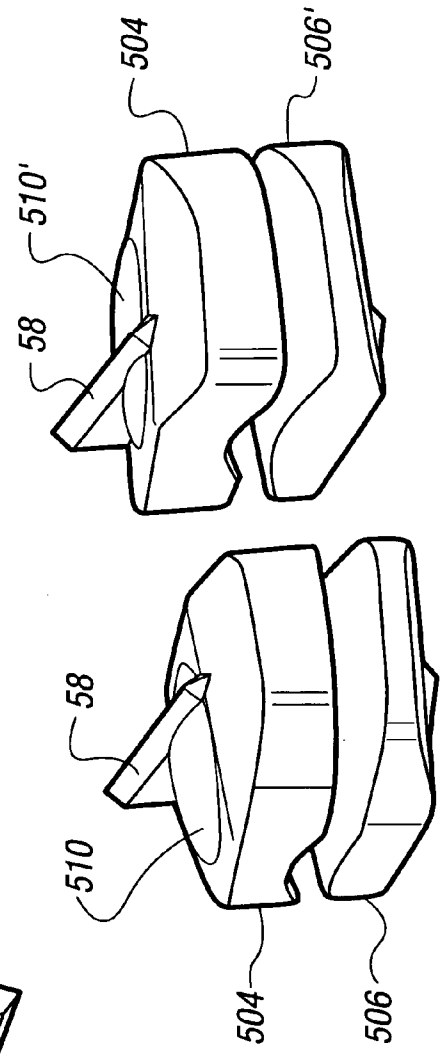
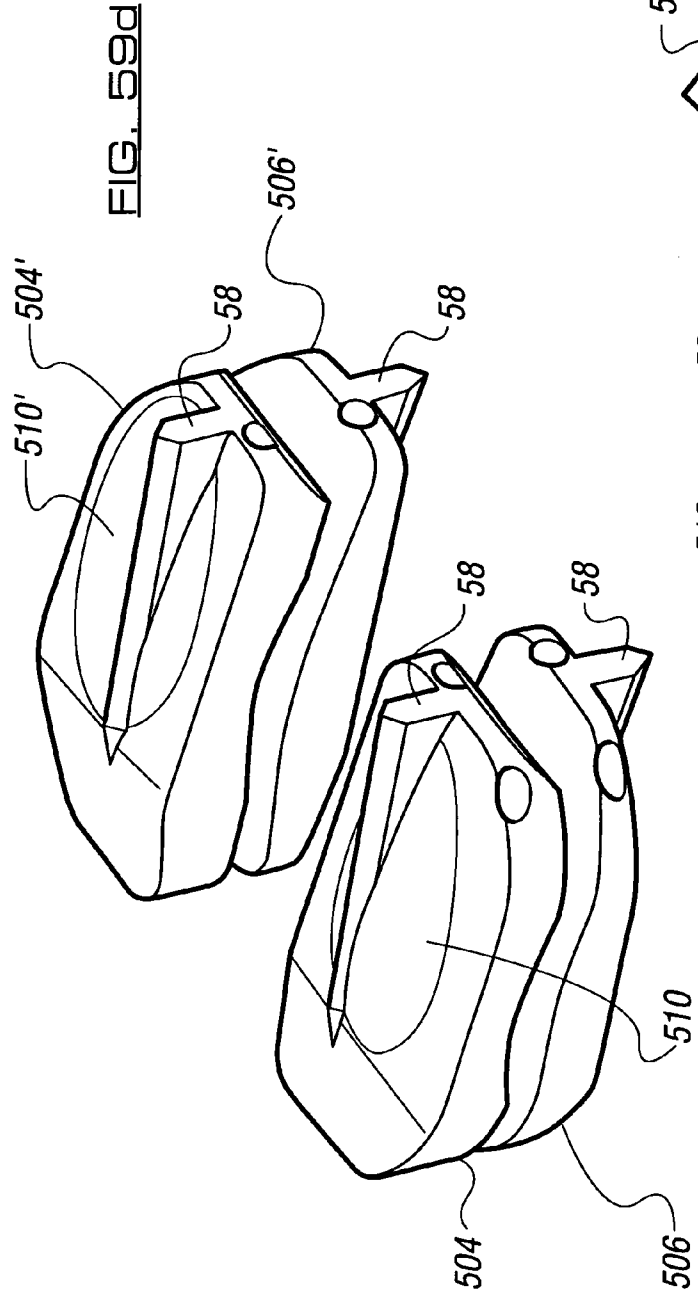

FIG. 518

FIG. 519



**FIG. 59e**

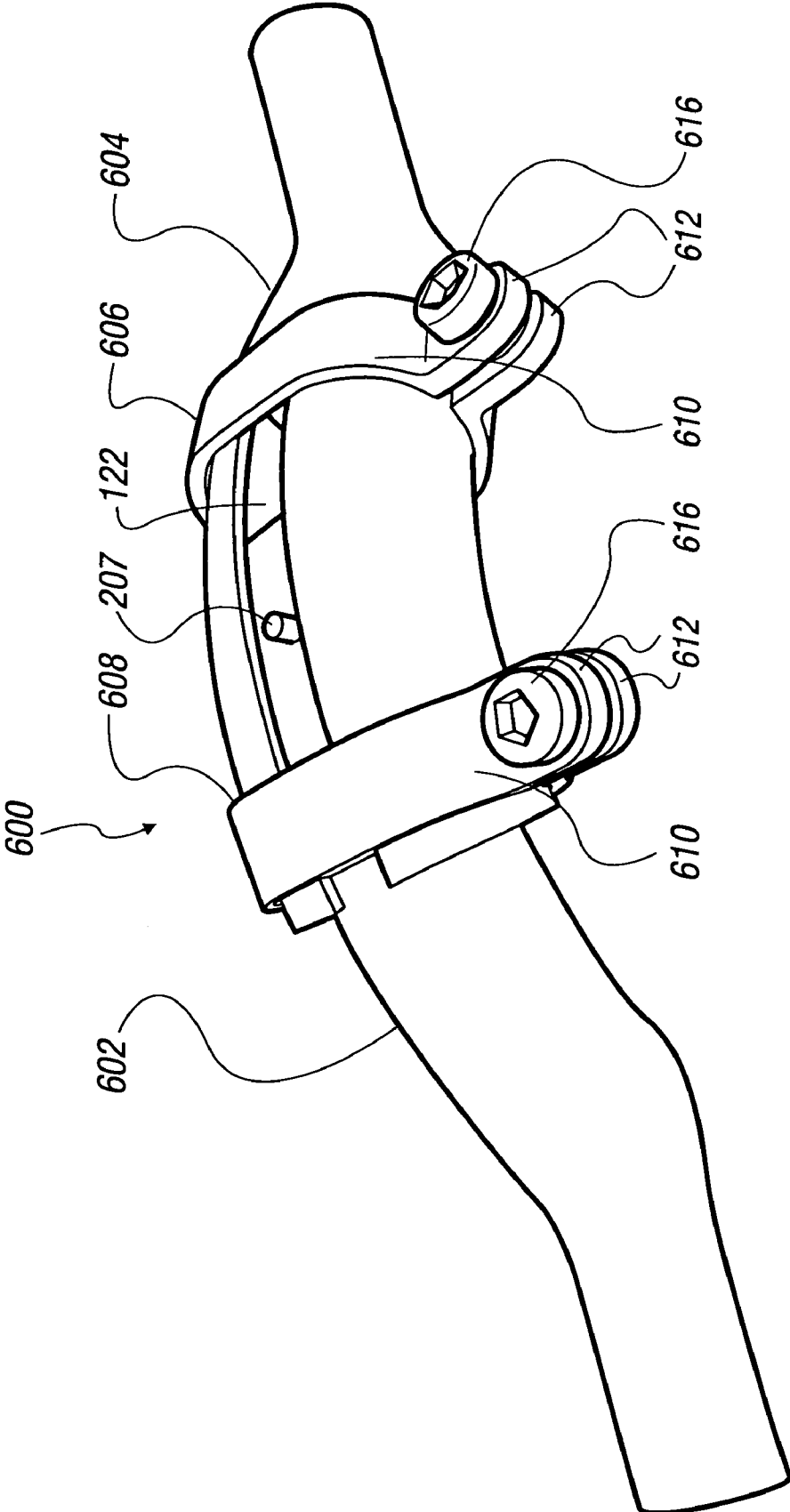

FIG. 60a

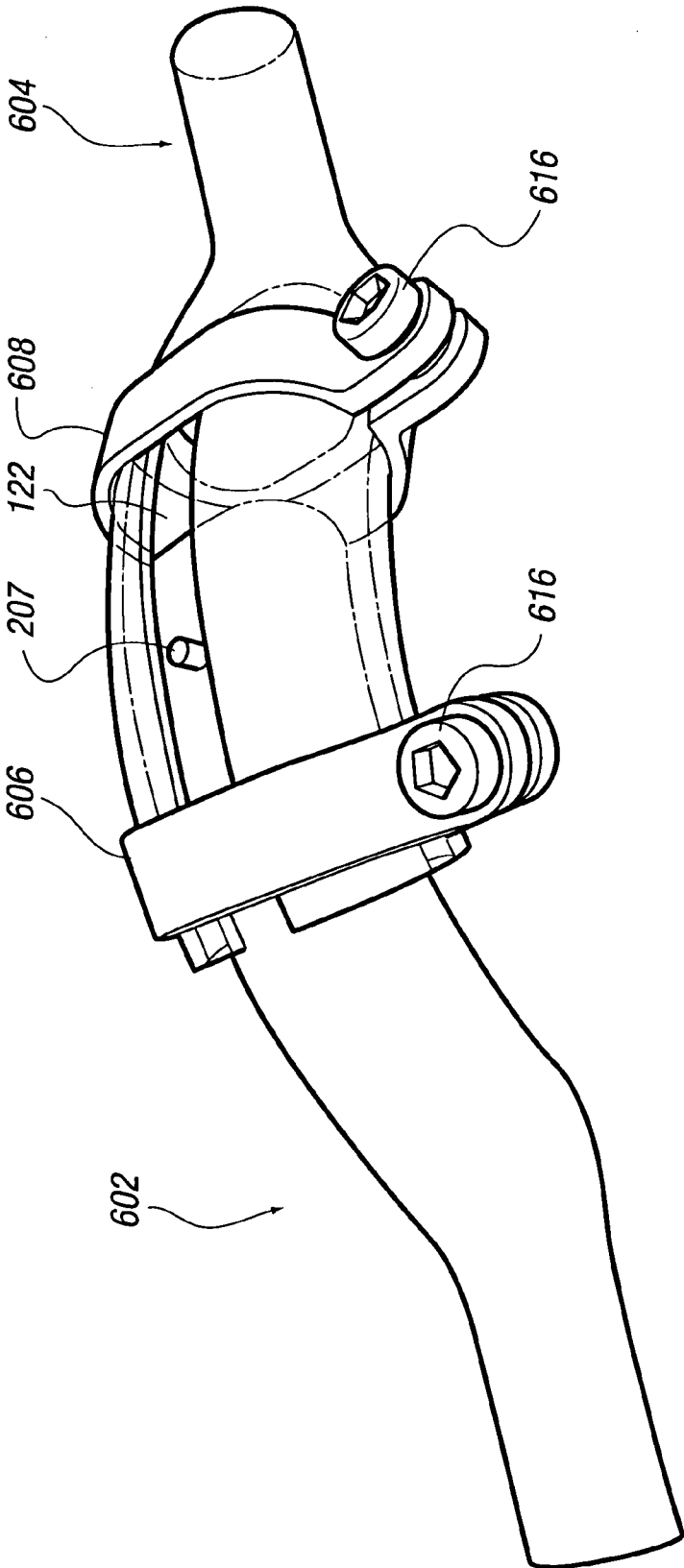

FIG. 600b

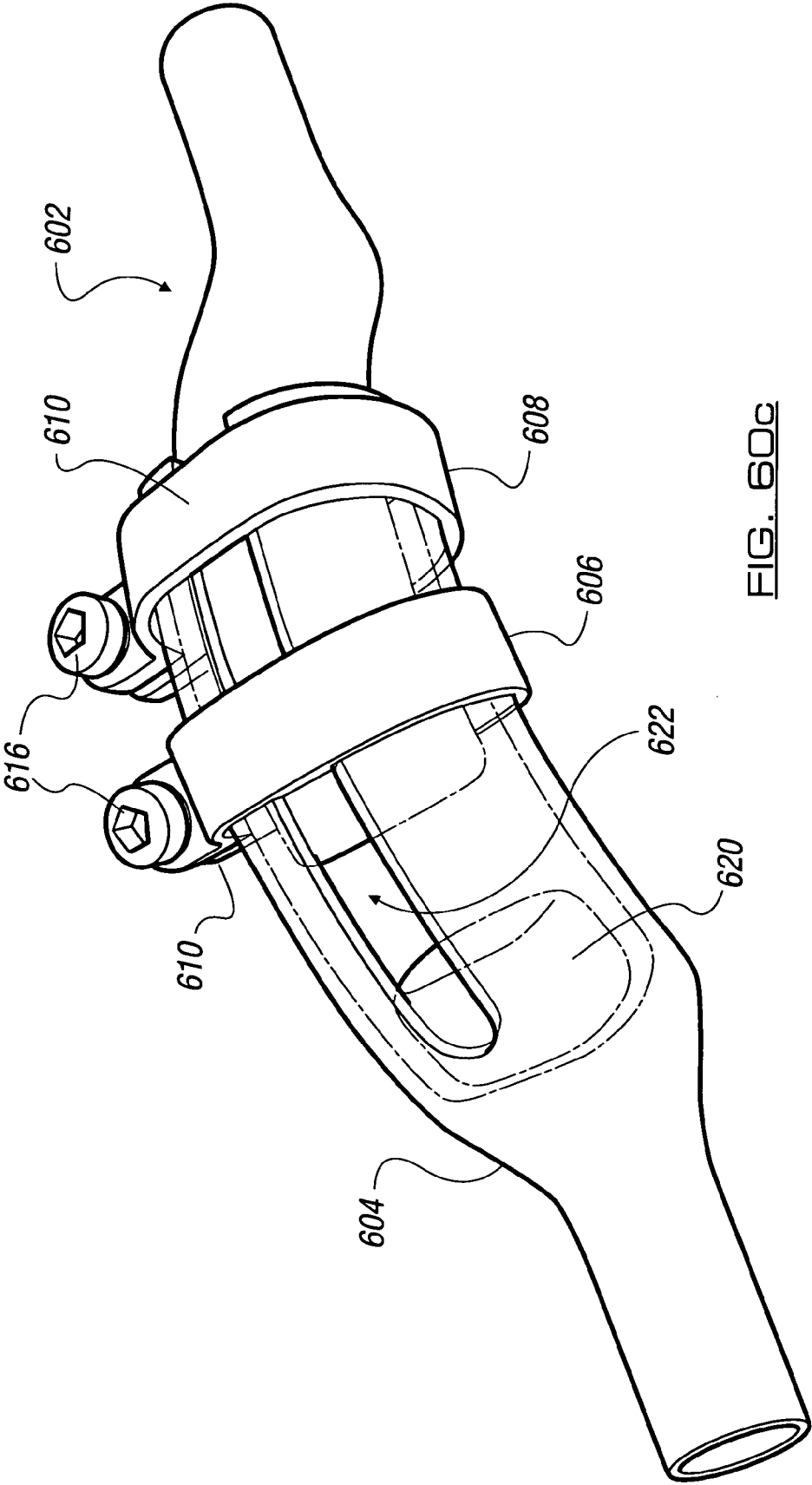

FIG. 600c

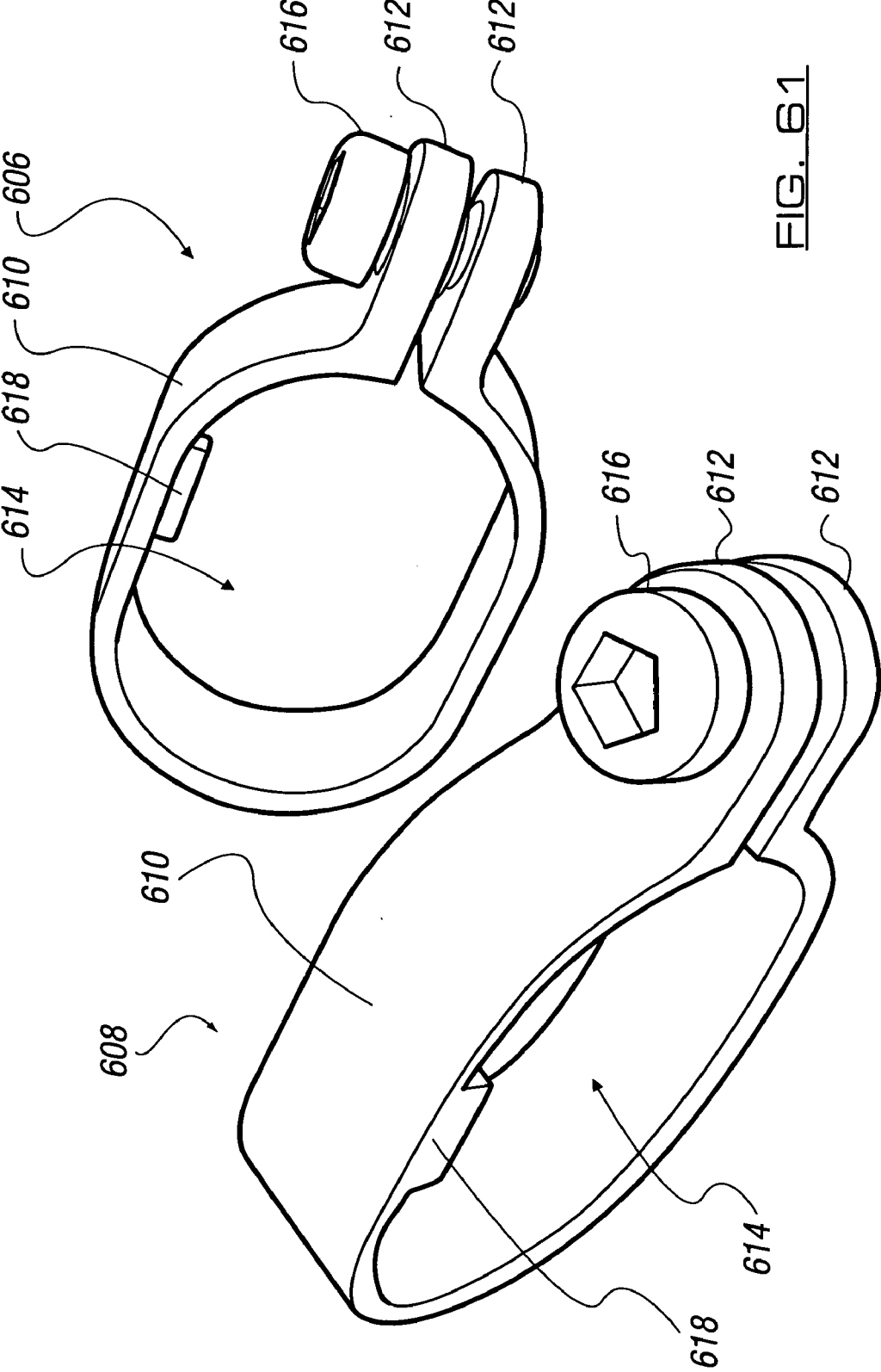

FIG. 61



**POSTERIOR SPINAL  
ARTHROPLASTY-DEVELOPMENT OF A NEW  
POSTERIORLY INSERTED ARTIFICIAL DISC, A  
NEW ANTERIORLY INSERTED ARTIFICIAL DISC  
AND AN ARTIFICIAL FACET JOINT**

REFERENCE TO PENDING APPLICATIONS

[0001] This application is a continuation-in-part of pending U.S. application Ser. No. 11/203,259 filed on Aug. 12, 2005, which is a continuation-in-part of pending U.S. Application No. 10/970,091 filed on Oct. 21, 2004.

FIELD OF THE INVENTION

[0002] This invention relates to devices and surgical methods for the treatment of various types of spine pathologies. It deals with the development of an artificial facet joint, and an artificial lumbar disc replacement that is specifically designed to be inserted from a posterior approach to the spine. It also deals with the development of an artificial disc replacement that can be inserted from an anterior approach to the spine.

BACKGROUND OF THE INVENTION

[0003] Back pain affects 40% of the population. Up to 20% of the population visit their family doctor requesting help with their back problem. Up to 30% of patients continue to complain of significant back pain at one year following the onset of their symptoms.

[0004] Although the majority of patients have minor sprains or strains which are self limiting, a significant number of patients go on to develop severe chronic mechanical lower back pain which is caused by inflammatory changes in the lumbar disc associated with degeneration.

[0005] Another group of patients with degenerative spine disease go on to develop degenerative spondylolisthesis and spinal stenosis. This is a narrowing of the spinal canal caused primarily by degenerative changes in the facet joint, combined with a loss of normal disc height and buckling of the ligamentum flavum.

[0006] Degeneration occurs in a spinal segment. The spinal segment consists of the lumbar disc anteriorly and two facet joints posteriorly. This is therefore called a three joint complex. Degenerative changes in the disc can lead to changes in the facet joint and vice versa. In patients with significant lumbar disc degeneration, the facet joints are also usually degenerate.

[0007] Pain occurs from all components of the three joint complex, including the facet joints and the disc. The facet joint is in fact a synovial joint and suffers from the problems that are known to affect other synovial joints in the body like the hip and the knee. The facet joint particularly contributes to degenerate spondylolisthesis and commonly occurs at levels where the facet joints are sagittally orientated, for example at the L4/5 level.

[0008] After failing all the conservative treatments available, a minority of patients with back pain or leg pain will go on to require surgical intervention. For patients with predominantly lower back pain who have a degenerative lumbar disc, some surgeon's consider the solution lies in

removing the pain generator which is the disc and restoring normal loading across the disc by doing an inter-body stabilisation procedure.

[0009] The two types of inter-body stabilisation procedure currently available are an artificial disc replacement performed anteriorly and inter-body fusions performed anteriorly and/or posteriorly. These inter-body stabilisation procedures are often combined with decompression of the spinal canal and the nerve roots if there is nerve root impingement.

[0010] As far as inter-body fusions are concerned, there are two basic strategies that surgeons adopt. The first is to perform an anterior inter-body fusion combined with posterior stabilisation externally of the spinal canal. Anterior inter-body fusion on its own is still questioned because it does not provide a posterior tension band. An alternative strategy is a posterior lumbar inter-body fusion, where the entire inter-body fusion procedure is performed from behind and it is combined with neural decompression as well as removal of the degenerative facet joints. Posterior lumbar inter-body fusion also provides a posterior tension band. This strategy therefore deals with all three joint components which can generate possible pain at the disc level, including the lumbar disc, the neural structures and the facet joints.

[0011] When it comes to lumbar disc arthroplasty procedures, these are performed via an anterior lumbar approach. The disc is removed and an artificial lumbar disc is inserted into the space. This removes the pain generator and allows normal loading across the disc, as well as allowing some movement at this level. The advantage of this is to reduce the strains on the disc above and therefore reduce the chances of adjacent segment degeneration. Several studies have shown that adjacent segment degeneration can occur above a fused segment because of the increased loads being transmitted to this level.

[0012] One of the disadvantages of anterior lumbar arthroplasty is that the facet joints at this level continue to move and also continue to act as a pain generator. In addition, if there is any neural impingement, these symptoms can continue. The other disadvantage of anterior lumbar arthroplasty is that the majority of spine surgeons are not familiar with the anterior approach, and although complications are uncommon, they can be life and limb threatening when they do occur.

[0013] There is therefore a concern among researchers and the surgical community, that long term results of anterior lumbar disc arthroplasty may be compromised by progressive degeneration of the facet joint at the same level. In addition, after lumbar disc arthroplasty, several patients continue to complain of facet joint pain because of increased loads being placed on the facet joint as a result of the surgical procedure.

[0014] At present there is no posterior lumbar arthroplasty procedure available. It is therefore an aim of the present invention to provide an artificial lumbar disc that can be inserted posteriorly, thereby delivering the advantages of approaching the spine posteriorly and removing the disadvantages associated with approaching the spine anteriorly.

[0015] It is a further aim of the present invention to provide a facet joint replacement prosthesis.

[0016] It is a yet further aim of the present invention to provide a lumbar prosthetic system that deals with the painful disc, the neural impingement and the painful facet joints by providing a combination of a lumbar disc prosthesis and a facet joint prosthesis as a single unit.

[0017] It is a further aim of the present invention to provide an artificial disc prosthesis that utilises one or more of the features and advantages provided by the posteriorly inserted disc but which can be inserted anteriorly.

[0018] It is a yet further aim of the present invention to provide a prosthetic system that deals with the painful disc, the neural impingement and the painful facet joints by providing a combination of a disc prosthesis and a facet joint prosthesis as a single system that works together.

#### SUMMARY OF THE INVENTION

[0019] According to a first aspect of the present invention there is provided a disc prosthesis, said disc prosthesis including a pair of disc members, the first member of said disc pair having a vertebral endplate contact surface and a recessed portion on an opposing surface thereof, the second member of said disc pair having a vertebral endplate contact surface and a protruding portion on an opposing surface thereof, the protruding portion of the second member engaging with the recessed portion of the first member in use, and wherein the inner or opposing surface of at least the first disc member is provided with at least three sections; a middle section and at least two end sections, the recessed portion being provided in the middle section and the thickness or depth of the middle section being less compared to the two end sections thereof.

[0020] In one embodiment the end sections, typically located adjacent the anterior and posterior edges of the prosthesis are substantially surfaces which are planar in form. Thus, the planar end sections are different in form to the curved middle recessed section.

[0021] The geometry of the middle and end sections of at least the first disc member allows contact to be made between the recessed and protrusion portions of the first and second disc members and for a gap to be formed adjacent the end sections of the disc members when the prosthesis is in a neutral position. When the prosthesis is in extension (i.e. the upper or first disc member moves posteriorly relative to the lower or second disc member), the gap between the end section at the anterior end increases, thereby causing the annulus anteriorly to tighten. Due to the geometry of the planar slopes within the prosthesis, the annulus will tighten not only anteriorly in flexion but laterally as well. This results in a physiological stop to further extension. Similarly in flexion the upper disc member moves anteriorly relative to the lower disc member, resulting in an increased gap posteriorly between the two disc members, and this causes the annulus posteriorly and laterally to tighten, resulting in a physiological stop to further flexion.

[0022] In one embodiment the middle section is located substantially centrally of the prosthesis. The end sections can be of substantially the same dimensions or substantially different dimensions.

[0023] Preferably the inner or opposing surface of the second disc member is provided with at least three sections;

a middle section and at least two end sections, the protruding portion being provided in the middle section of the disc member.

[0024] In one embodiment the boundaries of the middle and end sections of one or both disc members can be arranged transversally thereof (i.e. in medial to lateral plane).

[0025] In one embodiment the boundaries of the middle and end sections of one or both disc members are arranged in anterior/posterior plane.

[0026] The middle and end sections of one or both disc members can be arranged along substantially the entire length thereof, or the middle and end sections of one or both disc members can be arranged in a substantially central part of the disc members.

[0027] In the embodiment where the prosthesis is inserted anteriorly, the middle or recessed portion of the first member is substantially curved and the curvature of the medial part of said recessed portion is substantially symmetrical to the curvature of the lateral part of said recessed portion. Thus, the lateral part of the recessed or middle portion has curvature corresponding to an arc of a circle which has a radius substantially equal to that of an arc of a circle corresponding to the curvature of the medial part of the recessed portion or middle section.

[0028] Preferably an anterior part of the recessed portion or middle section is substantially symmetrical to a posterior part of the recessed portion. The symmetry of the parts of typically about the mid point of the middle section.

[0029] In the anteriorly inserted embodiment, the protrusion portion of the second member is typically of substantially the same shape and/or dimensions as the recessed portion of the first member.

[0030] In the anteriorly inserted embodiment, the protrusion portion is preferably a rugby ball type shape with the radius of the curve of the protrusion portion in the medial-lateral plane being larger than the radius of the curve of the protrusion portion in the anterior-posterior plane. Thus, the protrusion portion is typically asymmetrical in the anterior-posterior plane compared to the medial to lateral plane.

[0031] Preferably one or both end sections of the inner or opposing surfaces of said first and/or second members are provided at an acute angle to the horizontal. For example, the inner end section surface of said first member can slope downwardly towards one or both ends of said member. The inner end section surface of said second member can slope downwardly towards the one or both ends of said member.

[0032] In the anteriorly inserted embodiment, the disc members are formed so as to have lordosis provided therein, such that the overall posterior height of the disc pair when assembled together is less than the anterior height.

[0033] Further preferably the outer and/or inner surfaces of said second disc member form a narrowing taper towards one or both ends of said disc member.

[0034] Preferably one or both ends of the first and/or second disc members have a narrowing taper (i.e. the ends of the prosthesis as a whole has a narrowing taper). This narrowing taper is as a result of the outer or vertebral end plate contact surface of said first and/or second disc member

being provided at an acute angle with respect to the horizontal at one or both ends. These angled surfaces are preferably substantially planar in form. For example, the outer or vertebral end plate contact surface of the first disc member slopes downwardly towards the ends of the disc member and/or the outer or vertebral end plate contact surface of the second disc member slopes upwardly towards the ends of the disc member. The narrowing taper of the prosthesis is particularly advantageous as it allows easy insertion of the prosthesis in the disc space via a posterior route.

[0035] In one embodiment, such as for example in the posteriorly inserted prosthesis, the narrowing taper is provided at an anterior end of the prosthesis. Thus, the outer surfaces or vertebral endplate contact surfaces of the disc member(s) slope towards the opposing surfaces thereof at the anterior end of the disc member(s). This provides a "lead in" feature which increases the ease with which the front of the prosthesis can be inserted via a posterior route into the disc space. In this embodiment, where the disc is inserted through the posterior route, the overall height of the anterior part of the disc pair is greater than the posterior height, so as to place the two vertebral endplates in lordosis, when the discs are inserted.

[0036] In one embodiment, a narrowing taper is provided at the posterior end of the prosthesis. Thus, for example, the outer surfaces or vertebral endplate contact surfaces of the disc member(s) slope towards the opposing surfaces thereof at the posterior end of the disc member(s). The posterior angled surface allows the prosthesis in the neutral position to be placed such that the vertebral end plates are in lordosis

[0037] The posterior end of the prosthesis typically slopes or tapers in an opposite direction to the anterior end.

[0038] Preferably the anterior end slope is substantially smaller than the posterior end slope in the embodiment where the disc prosthesis is inserted posteriorly.

[0039] Further preferably the outer and inner surface of said first disc member form a narrowing taper adjacent an end of said disc member in which attachment screws are to be located there through. The screw insertion hole is located posteriorly in the embodiment where the discs are inserted from the posterior route, and anteriorly where the discs are inserted through the anterior route.

[0040] Preferably the vertebral endplate contact surface of the first and/or second members of each disc pair is provided with attachment means for allowing attachment of the disc member to an adjacent disc in use.

[0041] The attachment means can include any or any combination of one or more screws, one or more apertures for the location of screws and/or any other suitable attachment device therewith, one or more tapered members, spikes or fins and/or any other conventional attachment apparatus.

[0042] In one embodiment the vertebral endplate contact surface of the first member of each disc pair includes a curved or convex shaped portion thereon. Preferably the disc pair is a lumbar disc prosthesis which can be inserted anteriorly but preferably posteriorly.

[0043] Preferably the contours of the curved or convex shape portion corresponds substantially (i.e. is substantially complementary) to the concave or curved shape portion of

the end surface of the vertebral body which the vertebral endplate contact surface of the prosthesis engages with in use. This provides an improved fit of the prosthesis in the disc space.

[0044] Preferably the longitudinal axis of the curved or convex shaped portion is parallel to the anterior-posterior axis of the vertebral endplate contact surface.

[0045] Preferably the height of the curved or convex shaped portion is greater towards the medial side than the lateral side. Thus the vertebral endplate contact surface slopes upwardly from the lateral side to the medial side.

[0046] The angle between the vertebral endplate contact surface of the first and second members or upper and lower disc members is approximately 7 degrees on the lateral side, but can vary.

[0047] Preferably the curved or convex shape portion on the vertebral endplate contact surface is substantially symmetrical about the anterior-posterior axis and/or medial to lateral axis.

[0048] The first and second members of the disc pair typically correspond to upper and lower disc members. The superior surface of the lower disc member has a protrusion thereon and the inferior surface of the upper disc member has a captive recess or socket thereon.

[0049] Preferably the recessed portion has two sloped surfaces associated therewith, typically corresponding to the end sections thereof, one surface leading anteriorly to the edge of the inferior surface and one surface leading posteriorly to the edge of the inferior surface. These sloping surfaces can be planar or can be slightly concave in form, but generally do not form the arc of a radius.

[0050] Preferably the disc prosthesis can be used in the cervical and/or lumbar spine in the embodiment where the prosthesis is inserted anteriorly.

[0051] Preferably the disc prosthesis can be used in the lumbar and/or thoracic spine where the prosthesis is inserted posteriorly.

[0052] The disc prosthesis of the present invention can be used to replace lumbar discs either anteriorly or posteriorly, and cervical discs anteriorly.

[0053] In the embodiment where the disc prosthesis of the present invention is inserted posteriorly, two disc pairs are required.

[0054] Thus, according to a second aspect of the present invention there is provided a lumbar disc prosthesis, said lumbar disc prosthesis including a pair of disc members, the first member of said disc pair having a vertebral endplate contact surface and a recessed portion on an opposing surface thereof, the second member of said disc pair having a vertebral endplate contact surface and a protruding portion on an opposing surface thereof, the protruding portion of the second member engaging with the recessed portion of the first member in use, and wherein the spinal disc prosthesis includes a further pair of disc members, said further pair of disc members also including first and second members.

[0055] Preferably the disc pairs are mirror images of each other.

[0056] Thus, the second aspect of the present invention provides a lumbar disc prosthesis having two disc member pairs and thus two separate articulating portions, one articulating portion on each pair of disc members. The disc member pairs are each independently inserted into the disc space on either side of the dural sac in use through the trans-foraminal or posterior route bilaterally and are provided a spaced distance apart in use to allow accommodation in accordance with the anatomy of the lateral aspect of the disc space. Thus, the disc prosthesis can be inserted through the posterior route whilst taking into account the neural anatomy posteriorly.

[0057] The lumbar disc prosthesis of the present invention can be inserted at all levels between L2 and the sacrum, typically depending on the level of expertise of the operating surgeon.

[0058] Preferably the first members of each disc pair are provided in the left and right areas of the disc space respectively in use. The second members of each disc pair are also provided in the left and right areas of the disc space respectively in use. Thus, each pair of members constitutes a left and right lumbar disc prosthesis.

[0059] In the posteriorly inserted lumbar disc prosthesis, the recessed portion or middle section of the first member is substantially curved and the curvature of the medial part of said recessed portion is asymmetrical to the curvature of the lateral part of said recessed portion.

[0060] The purpose of this asymmetry in the medial-lateral plane is to allow "capture" of the protruding portion of the second member. such that when two pairs of disc prostheses are placed in the patient, the two vertebrae can move from side to side as well as anteriorly and posteriorly.

[0061] In the posteriorly inserted embodiment, preferably the lateral part of the recess has curvature corresponding to an arc of a circle which has a radius greater than that of an arc of a circle corresponding to the curvature of the medial part of the recessed portion. Further preferably the radius of the lateral part is at least twice as big as the radius of the medial part

[0062] Preferably an anterior part of the recessed portion is substantially symmetrical to a posterior part of the recessed portion.

[0063] In the posteriorly inserted embodiment, the protrusion portion of the second member is typically of different shape and/or dimensions to the recessed portion of the first member. Thus, in one embodiment the protrusion portion is asymmetrical or forms an asymmetrical fit with the recessed portion. In an alternative embodiment the protrusion portion is symmetrical or forms a symmetrical fit with the recessed portion.

[0064] In the posteriorly inserted embodiment, the protrusion portion is preferably substantially dome shaped and makes contact with only a part of the recessed portion when assembled. However, the protrusion portion could contact a substantial part of the recessed portion when assembled if required.

[0065] Preferably the recessed portion is substantially an inverted dome shape.

[0066] In the posteriorly inserted embodiment, the protrusion portion is typically symmetrical in the anterior-posterior plane and in the medial to lateral plane. The curvature in the medial to lateral plane can be the same or different to that in the anterior to posterior plane.

[0067] According to a further aspect of the present invention there is provided a lumbar disc prosthesis, said disc prosthesis including a pair of disc members, the first member of said disc pair having a vertebral endplate contact surface and a recessed portion on an opposing surface thereof, the second member of said disc pair having a vertebral endplate contact surface and a protruding portion on an opposing surface thereof, the protruding portion of the second member engaging with the recessed portion of the first member in use, and wherein the vertebral endplate contact surface of said first member includes a convex shaped portion thereon.

[0068] The lumbar disc prosthesis can be used in conjunction with a facet joint prosthesis also provided posteriorly to provide a system which can work together as a single unit to replace the painful disc, overcomes neural impingement and painful facet joints.

[0069] The facet joint prosthesis is formed such that the arc of rotation of the facet joint substantially matches the arc of rotation of the posterior disc prosthesis. As such, the "Instant Axis of Rotation" (IAR) of the two prostheses forming the unit is substantially the same. Furthermore, the facet joint prosthesis stabilises and can unload the posterior disc prosthesis by pre-loading the segment into kyphosis.

[0070] Preferably the facet joint prosthesis typically includes a first member for attachment to a first vertebra of a corresponding disc and a second member for attachment to a second vertebra of a corresponding disc in use, and wherein at least a part of said first member is telescopically or slidably mounted in at least a part of said second member in use.

[0071] Preferably the first and second members are elongate members and the provision of one telescopically mounted in the other allows the distance between parts of the first and second members to be increased and/or decreased as required.

[0072] The first vertebra is typically an upper vertebra and the second vertebra is typically a lower vertebra.

[0073] The facet joint prosthesis allows replacement of existing facet joints to be undertaken at all lumbar levels from T12 to the sacrum.

[0074] The interconnecting first and second members are formed such that they can articulate to allow flexion-extension, small degrees of rotation and side to side flexion.

[0075] Preferably securing means are provided for insertion of the first and second members into each of the vertebral bodies above and below the disc between which the facet joint prosthesis is to be located. The first and second members can then be secured to said securing means. A plurality of first and second members can be attached to the securing means if required to form a stack, thereby allowing facet joint replacement at multiple levels within the spine.

[0076] The securing means can include any suitable type of surgical securing device, such as a pedicle screw.

[0077] In one embodiment the ends of the first and/or second members which are to be attached to the vertebral bodies are provided with at least one aperture through which the securing means are located.

[0078] In one embodiment the ends of the first and/or second members which are to be attached to the vertebral bodies are provided with substantially rounded and/or continuous ends to allow a clamp and pedicle screw or other securing means to be associated with the same.

[0079] Preferably locking means are provided on the first and/or second members to allow locking of the members together. The locking means can include any or any combination of one or more interengaging portions, one or more locking screws and/or the like.

[0080] In one embodiment the locking means includes one or more clamping rings. The clamping rings are located around the first and second members and can clamp the members in a suitable position relative to each other by applying a suitable clamping force thereto. The clamping force can be provided using one or more screws and/or the like.

[0081] Preferably each clamping ring is of sufficient size and dimensions to substantially encompass the outermost member. The free ends of the clamping ring can be moved towards or apart from each other using said one or more screws and/or other suitable engagement means.

[0082] Preferably two clamping rings are used to clamp the first and second members together. Movement of the clamping rings relative to each other on the members determines the range of movement of the first member relative to the second member and thus the range of movement of the facet joint prosthesis. Use of the clamping rings allows the prosthesis to achieve micro-motion or full motion. It also allows the prosthesis to act as a fusion rod or a dynamic rod, thereby allowing the prosthesis to be multi-functional and more flexible in its application.

[0083] Preferably guide means are provided on the first and/or second members to allow relative movement therebetween to be controlled or guided. The guide means can include a slot or enclosed channel provided on one of said members in which a rod or protrusion provided on the other of said members is slidably mounted. This is to prevent the two members of the facet prosthesis from disassociating from each other.

[0084] The clamping rings can be used to limit movement of the protrusion in the slot or enclosed channel or male member.

[0085] Preferably an interior surface of the clamping ring is provided with a protrusion part thereon which locates in said channel or slot when fitted to the device.

[0086] In one embodiment the slot provided on one of said members can be open ended.

[0087] Preferably a stop member is located in the channel of said second member. The stop member can act as a shock absorber. The stop member is preferably removably located in said channel.

[0088] In one embodiment a sleeve, made of any suitable material, such as for example silicon, plastic and/or the like can be present to cover the facet articulation.

[0089] According to a further aspect of the present invention there is provided a lumbar disc prosthesis, said lumbar disc prosthesis including a pair of disc members, the first member of said disc pair having a vertebral endplate contact surface and a recessed portion on an opposing surface thereof, the second member of said disc pair having a vertebral endplate contact surface and a protruding portion on an opposing surface thereof, the protruding portion of the second member engaging with the recessed portion of the first member in use, and wherein the recessed portion of the first member is substantially curved and the curvature of the medial part of said recessed portion is asymmetrical to the curvature of the lateral part of said recessed portion.

[0090] According to a yet further aspect of the present invention there is provided a facet joint prosthesis, said prosthesis including a first member for attachment to a first disc in use and a second member for attachment to a second disc in use, and wherein at least a part of said first member is telescopically or slidably mounted in at least a part of said second member in use.

[0091] The facet joint prosthesis can be used alone or in combination with the disc prosthesis of the present invention. The facet joint replacement procedure of the present invention alone will have a role in the treatment of patients with spinal stenosis and adjacent level disc disease, where some stability is required at the disc level without fusing a particular disc segment. The facet prosthesis can partially constraining certain degrees of motion.

[0092] According to further independent aspects of the present invention there is provided a prosthesis system including a disc prosthesis and a facet joint prosthesis as hereinbefore described; a first or upper disc member; a second or lower disc member; a method of insertion of a lumbar disc prosthesis in a patient via a posterior route; a method of insertion of a facet joint replacement prosthesis in a patient via a posterior route and/or anterior route; and a method of insertion of a lumbar disc prosthesis in a patient via an anterior route;

[0093] According to an aspect of the present invention there is provided a prosthesis system, said system including a disc prosthesis and facet joint prosthesis, said disc prosthesis including a pair of disc members, the first member of said disc pair having a vertebral end plate contact surface and a recessed portion on an opposing surface thereof, the second member of said disc pair having a vertebral endplate contact surface and a protruding portion on an opposing surface thereof, the protruding portion of the second member engaging with the recessed portion of the first member in use, said facet joint prosthesis including a first member for attachment to a first posterior lumbar disc in use and a second member is provided for attachment to a second posterior lumbar disc in use, and wherein at least a part of said first member is telescopically mounted in at least a part of said second member in use.

[0094] It will be appreciated by persons skilled in the art that the upper or lower disc member in any of the embodiments can be used alone if required.

[0095] Any of the abovementioned features can be used alone or in combination with each other in a prosthesis according to the present invention.

[0096] Thus, the present invention overcomes the problems and disadvantages associated with current disc replacement strategies. It has all the benefits associated with posterior lumbar inter-body fusion surgery, but at the same time it allows movement at that level and reduces the strain on adjacent discs and the risks of adjacent segment disc failure. This invention also addresses all three pain generators at the lumbar disc level including the degenerative disc, the impingement of the neural structures, and the facet joint.

#### BRIEF DESCRIPTION OF THE DRAWINGS

[0097] Generally, **FIGS. 1-30** and **59a-59e** relate to a lumbar disc prosthesis according to embodiments of the present invention for insertion via a posterior route, **FIGS. 31-52b** and **60a-61** relate to a facet joint replacement prosthesis according to embodiments of the present invention; and **FIGS. 53a-58e** show lumbar and cervical disc prosthesis according to embodiments of the present invention for insertion via an anterior route. More particularly,

[0098] **FIG. 1** is a side view of a lumbar disc prosthesis according to one embodiment of the present invention;

[0099] **FIGS. 2-4** show the prosthesis in **FIG. 1** with the upper disc member in extension, flexion and in a neutral position respectively;

[0100] **FIGS. 5 and 6** show the superior surfaces of the upper members of the left and right lumbar prosthesis pairs respectively;

[0101] **FIGS. 7 and 8** show rear views of the left and right lumbar prosthesis pairs respectively;

[0102] **FIGS. 9 and 10** show front views of the left and right lumbar prosthesis pairs respectively;

[0103] **FIGS. 11 and 12** show oblique views of the left and right lumbar prosthesis pairs respectively;

[0104] **FIGS. 13 and 14** show the superior surfaces of the lower members of the left and right lumbar prosthesis pairs respectively;

[0105] **FIGS. 15 and 16** show rear views of the lower members of the left and right lumbar prosthesis pairs respectively;

[0106] **FIG. 17** is a side view of the lower member of a lumbar prosthesis;

[0107] **FIGS. 18 and 19** show front views of the lower members of the left and right lumbar prosthesis pairs respectively;

[0108] **FIGS. 20 and 21** show oblique views of the lower members of the left and right lumbar prosthesis pairs respectively;

[0109] **FIG. 22** is a side view of an upper member of a lumbar prosthesis pair to illustrate the angulations and geometry of the inferior surface thereof;

[0110] **FIG. 23** is a front view of the upper member of the lumbar prosthesis pair to illustrate the radius in the medial and lateral part of the curvature of the inferior surface;

[0111] **FIG. 24** is an oblique view of the upper member of the lumbar prosthesis pair to further illustrate the shape of the inferior articulating surface thereof;

[0112] **FIG. 25** shows a perspective view of the inferior surface of the upper members of the left and right lumbar prosthesis pairs respectively;

[0113] **FIGS. 26a-d** illustrates a) a solid inverse representation of the recess portion shape on the inferior surface of the upper member of the prosthesis b) an axial view of the prosthesis c) a side view and d) a front view showing the medial/lateral asymmetry of the prosthesis;

[0114] **FIG. 27** is a cross section through the upper member of a lumbar prosthesis pair showing the medial lateral curvature of the articulating surface;

[0115] **FIG. 28** show front views of the left and right lumbar prosthesis pairs respectively in an alternative embodiment with the screws replaced by fin members;

[0116] **FIGS. 29a and 29b** illustrate oblique views of the left and right lumbar prosthesis pairs in **FIG. 28** joined together and spaced apart respectively;

[0117] **FIGS. 30a-30f** show a) superior surfaces of the upper members of the left and right lumbar prosthesis pairs in **FIG. 28** b) a side view c) a front view d) a further side view e) inferior surfaces of the lower members of the left and right lumbar prosthesis pairs and f) oblique views of the pairs;

[0118] **FIG. 31** is a side view of a facet joint replacement prosthesis according to an embodiment of the present invention;

[0119] **FIGS. 32-36** show a front view, end view, side view, rear view and oblique view respectively of the second or female member of the facet replacement prosthesis;

[0120] **FIG. 37** is a cross sectional view of the second or female member of the facet replacement prosthesis taken along the line marked A-A in **FIG. 34**;

[0121] **FIGS. 38-42** show a front view, end view, side view, rear view and oblique view respectively of the first or male member of the facet replacement prosthesis;

[0122] **FIG. 43** is a cross sectional view of the first or male member of the facet replacement prosthesis taken along the line marked A-A in **FIG. 40**;

[0123] **FIGS. 44a-44d** illustrate a side view, front view, perspective view from the rear and perspective view from the front of the facet joint replacement prosthesis in **FIG. 31**;

[0124] **FIGS. 45a and 45b** illustrate the ability of the male member to move within the female member and produce a flexion and extension movement of the vertebral body respectively;

[0125] **FIG. 46** illustrates end views of the facet replacement prosthesis showing the ability of the male and female components to undergo limited relative rotational movement;

[0126] **FIG. 47** illustrates front views of the facet replacement prosthesis showing the ability of the male and/or female components to undergo side to side flexion;

[0127] FIGS. 48a-48d show a side view, front view, perspective view from the rear and perspective view from the front of facet joint prostheses when stacked respectively;

[0128] FIG. 49 is an enlarged view of the ends of the female and male members of the facet joint prosthesis;

[0129] FIG. 50 is a cross sectional view taken through a pedicle screw attached to a female member of a facet joint prosthesis;

[0130] FIG. 51 is a perspective view of a facet joint replacement prosthesis according to a further embodiment of the present invention;

[0131] FIGS. 52a and 52b show perspective views of the facet joint prosthesis in FIG. 51 in a retracted and extended position respectively;

[0132] FIGS. 53a-53f show a lumbar disc prosthesis for insertion via an anterior route, particularly a top view of an upper disc member, anterior view of a pair of disc members, side view of a pair of disc members, posterior view of a pair of disc members, base view of a lower disc member, and anterior perspective view of a pair of disc members respectively;

[0133] FIGS. 54a-54f show the lower disc member in FIGS. 53a-53f, particularly a top view, anterior view, side view, posterior view, base view and perspective view respectively;

[0134] FIGS. 55a-55f show the upper disc member in FIGS. 53a-53f, particularly a top view, anterior view, side view, posterior view, base view and perspective view respectively;

[0135] FIGS. 56a-56f show a cervical disc prosthesis for insertion via an anterior route, particularly a top view of an upper disc member, anterior view of a pair of disc members, side view of a pair of disc members, posterior view of a pair of disc members, base view of a lower disc member, and anterior perspective view of a pair of disc members respectively;

[0136] FIGS. 57a-57f show the lower disc member in FIGS. 56a-56f, particularly a top view, anterior view, side view, posterior view, base view and perspective view respectively;

[0137] FIGS. 58a-58f show the upper disc member in FIGS. 56a-56f, particularly a top view, anterior view, side view, posterior view, base view and perspective view respectively;

[0138] FIGS. 59a-59e illustrates a further embodiment of first and second member disc pairs with the upper vertebral endplate contact surface having a convex shaped portion provided thereon;

[0139] FIGS. 60a-60c illustrate a perspective view and partial cross sectional view with clamping rings separated and a partial cross sectional view with the clamping rings together respectively; and

[0140] FIG. 61 illustrates clamping rings according to an embodiment of the present invention.

#### DETAILED DESCRIPTION OF THE PREFERRED EMBODIMENTS

##### Lumbar Disc Prosthesis for Insertion Via a Posterior Route

[0141] Referring firstly to FIGS. 1-30, there is illustrated a lumbar disc prosthesis 2 which can be inserted into a lumbar disc space via a posterior route as a replacement for a diseased and/or damaged lumbar disc.

[0142] The disc prosthesis 2 includes two pairs of disc members, each pair including an upper disc member 4, 4' and a lower disc member 6, 6'. (Use of a reference numeral with ' thereafter refers to a second or further feature equivalent to the feature indicated by the reference numeral alone. Thus, disc member 4 refers to the first prosthesis pair upper member and disc member 4' refers to the second prosthesis pair upper member). The upper and lower disc members 4, 6; 4', 6' of each pair constitute a left and right disc prosthesis respectively. These disc members are shaped and dimensioned such that they can be inserted into a lumbar disc space either side of the dural sac whilst taking into account the posterior neural anatomy

[0143] Each upper disc member 4, 4' includes a vertebral endplate contacting surface or superior surface 8, 8' and an inferior surface 10, 10'. Each lower disc member 6, 6' includes a superior surface 12, 12' and a vertebral endplate contacting surface or inferior surface 14, 14'.

[0144] A dome shaped protrusion 16 is formed substantially centrally of superior surface 12 of lower disc member 6. Protrusion 16 is received in a substantially central recess 18 on inferior surface 10 of upper disc member 4 as will be described in more detail below.

[0145] Both the superior surface 20 of upper member 4 and the inferior surface 22 of lower member 6 are angled to provide the prosthesis with a "lead in" or narrowing tapered feature. This lead in feature allows the prosthesis to enter the posterior disc space which is narrower than the anterior disc space. In addition to the lead in feature which is provided at the anterior or front end 24 of the prosthesis members, each prosthesis pair has a lordosis or narrowing taper angle towards the posterior or rear end 26 of the prosthesis members between the inferior surface 14 of the lower disc member 6 and superior surface 8 of the upper member 4 of approximately 6 degrees (this angle or any other angle mentioned hereinafter is for exemplary purposes and does not limit the invention in any way), as shown in FIG. 1. This makes the outer surfaces of the disc prosthesis pairs at the posterior and anterior ends substantially wedge shaped or tapered to allow ease of insertion into the disc space. The taper or angle of the outer surfaces at the posterior end is in an opposite direction to the taper or angle of the outer surface at the anterior end.

[0146] With reference to FIGS. 1-27, the superior surface of upper disc member 4 and the inferior surface of lower disc member 6 have attachment means in the form of screws 28 to allow attachment of the disc prosthesis to adjacent vertebrae when positioned in a patient. Apertures 30 are provided on the inferior and superior surfaces 10, 12 of the upper and lower disc members 4, 6 respectively of the prosthesis pairs to allow the insertion of screws 28 through the prosthesis disc members. The screws are typically fitted from the posterior end 26 and the screws and interior walls defining apertures 30 are provided at an acute angle to the

vertical to allow ease of attachment. Apertures **30** and screws **28** within each pair diverge outwardly away from each other towards anterior end **24**. The inferior surface on which these apertures are provided on the upper disc member is angled such that it slopes upwardly towards the superior surface of the upper disc member. The superior surface on which these apertures are provided on the lower disc member is angled such that it slopes downwardly towards the inferior surface of the lower disc member, thereby forming a narrowing taper at the posterior end of the lower disc member. These angled surfaces typically form, at least in part, the posterior end segments of the inferior and superior surfaces **48, 38** of the upper and lower disc members **4, 6** respectively. This feature is to allow ease of insertion of screws or other attachment means to anchor the prosthesis into the vertebra.

[0147] With the protrusion **16** on lower member **6** located in recess **18** of upper member **4** when the prosthesis is assembled, relative movement between the upper and lower members **4, 6** allows the prosthesis to undergo extension and flexion. The substantially dome shaped protrusion **16** contacts only a part of the recess **18** due to differences in symmetry and geometry. In the example illustrated, the upper member **4** can move with respect to the lower member **6** through approximately 10 degrees in a posterior direction to allow extension of the prosthesis, as shown in **FIG. 2**. Due to the nature of the inferior surface **10** of upper disc member **4**, as the upper member **4** goes into extension there is an increased distance adjacent anterior end **24** between the upper and lower members **4, 6**. This results in a tightening of the annulus anteriorly, as is seen in physiological extension in the disc.

[0148] The upper member **4** can also move with respect to lower member **6** through approximately 10 degrees in an anterior direction to allow flexion of the prosthesis, as shown in **FIG. 3**. Again, due to the nature of inferior surface **10**, as upper member goes into flexion there is an increased distance adjacent posterior end **26** between the upper and lower members **4, 6**. This results in a tightening of the annulus posteriorly and serves as a natural block to further flexion.

[0149] Referring to **FIGS. 13-21**, there are shown more detailed views of lower disc prosthesis member **6, 6'**. The dome shaped protrusion **16** is located in a central or intermediate section of superior surface **12** in the anterior to posterior plane. The anterior and posterior end sections **36, 38** either side of the dome section **40**, as shown by dotted lines **42**, are provided at an acute angle to the horizontal sloping downwardly from intermediate section **40** towards ends **24, 26** respectively. The angled surfaces **36, 38** are typically substantially planar in form. This downwards incline is to accommodate the flexion and extension of the upper disc member **4** without impingement therewith. In the medial and lateral plane, protrusion **16** extends substantially the entire distance between the sides of the prosthesis member or from the medial to the lateral edges **32, 34** respectively.

[0150] Referring to **FIGS. 22-27**, there is illustrated more detailed views of upper disc member **4** showing in particular the curvature and complex geometry of the inferior surface **10**. The surface **10** is divided into three distinct regions as with the superior surface of lower disc member **6**; a sub-

stantially central or intermediate section **44** and anterior and posterior end sections **46, 48** respectively. Each section typically occupies approximately one third of the inferior surface.

[0151] The central section **44** is substantially curved and forms an asymmetrical inverse dome shaped recess **18**. The curvature of the recess in the medial half (i.e. portion adjacent medial edge **32**) of the central section differs to the curvature of the recess in the lateral half (i.e. portion adjacent the lateral edge **34**) of the central section. More specifically, the medial half of the dome has a curvature corresponding to the arc of a circle having a radius of approximately 15 mm as shown by arrow **50**, whereas the lateral half of the dome has a curvature corresponding to the arc of a circle having a radius of approximately 40 mm, as shown by arrow **52** in **FIG. 23**. Thus, the curvature of the lateral half of the central section corresponds to an arc of a circle having a radius at least double that of the arc of a circle corresponding to the curvature of the medial half of the central section. The purpose of this asymmetry in the medial/lateral plane is to allow capture of the "dome" shaped protrusion **16** of the lower disc member, but still allow some medial and lateral movement of the disc members. This contributes to stability and prevents dislocation of the upper and lower disc members during movement. The shorter curvature of the medial half of the central section relative to the lateral half helps in the medial and lateral movement of the two vertebral bodies on the right and left prosthesis.

[0152] The anterior and posterior end sections **46, 48** are provided at an acute angle to the horizontal, typically approximately 12-14 degrees as shown in **FIG. 22**, and provide an incline sloping downwardly from the central section **44** to the anterior and posterior ends **24, 26** of the inferior surface respectively. The surface of the anterior and posterior end sections that runs from the central section to the edge of the anterior and posterior sections, as seen in **FIG. 25**, is generally planar, although a mild curvature or concavity to the surface can be provided. It is to be noted that the slope of the anterior section **46, 46'** ends before the anterior end, thereby leaving a small planar surface **54** adjacent anterior end **46, 46'**. In the lateral view, the edge of the anterior and posterior surfaces is substantially planar, and does not include a radius, so that the distance between the vertebrae increases in flexion and extension.

[0153] The curvature of the central section recess on the anterior to posterior axis corresponds to an arc of a circle having a radius of approximately 17 mm, as shown by arrow **56** in **FIG. 22**. This is designed so that in combination with the other geometric features of the prosthesis, anterior and posterior movement of the upper disc member is allowed with respect to the lower disc member of approximately 10 degrees, as previously described in relation to **FIGS. 2 and 3**, even if the prosthesis pairs are not exactly parallel to each other. This geometry is also designed to allow limited sideways (medial/lateral plane) tilt of the upper disc member on the lower disc member, allowing sideways movement of the two disc members on each other, such that the right and the left prosthesis move in tandem.

[0154] The geometry of the inferior surface of the upper disc member is also designed to allow limited rotation of the right or left prosthesis pairs. This means that if the upper disc



member of the right prosthesis pair moves anteriorly, the upper disc member on the left prosthesis pair moves posteriorly allowing limited rotation of the two vertebral members to occur.

[0155] The aim of the surgical procedure for the disc replacement is to insert the left and right prosthesis pairs as parallel to each other as possible within the disc space. However, even if there is medial tilt of between 0-25 degrees between the prosthesis pairs, anterior and posterior movement of the pairs will still be possible and the upper and lower disc members will remain articulated during this movement. Thus, one disc pair is located at one side of the disc space and the other disc pair is located at the opposite side of the disc space (i.e. in the medial lateral plane).

[0156] According to a further embodiment of the present invention, alternative attachment means can be provided in the form of fin members 58 on the superior surface 8 of the upper disc member 4 and on the inferior surface 14 of the lower disc member 6, as shown in FIGS. 28-30f. Fin members 58 anchor the disc prosthesis to adjacent vertebrae.

[0157] Fins 58 are substantially triangular in shape and are provided longitudinally of the prosthesis (i.e. between the posterior and anterior ends) towards the medial edge 32 of the disc members, so as to avoid the exiting nerve root which goes across the disc laterally. More specifically, the fins are located adjacent posterior end 26 and end before the lead in feature 20, 22 at the anterior end to avoid the exiting lumbar nerve root above the disc on the lateral side (i.e. they extend for approximately two-thirds of the disc surface). The fin has a narrowing taper from posterior end 26 towards anterior end 24.

[0158] With the disc prosthesis pairs fitted, the upper disc members typically move substantially symmetrically on the lower disc members as the upper vertebral body moves forward on the lower vertebral body. The anterior and posterior translations of these upper disc members are limited by a tightening of the anterior and posterior annulus in flexion and extension. This is designed to reflect the physiological process by which the anterior and posterior annulus tightens in flexion and extension in a normal lumbar disc.

[0159] It is to be noted that the end parts of the lateral side 34 of the disc members are curved to accommodate the lateral aspect of the disc space which is similarly curved, thereby allowing better anatomical placement. Thus, the lateral side includes an intermediate substantially straight/linear/planar surface with the end portions either side thereof curving inwardly towards the posterior and anterior ends respectively. The medial side 32 of the disc members is substantially straight/linear/planar.

[0160] Apertures 60 are defined in the posterior end 26 of the upper and lower disc members of each prosthesis pair to allow engagement of an insertion tool therewith so that the prosthesis pairs can be inserted into the disc space. Apertures 60 are typically a spaced distance apart and the apertures on the upper disc member are substantially aligned with the apertures on the lower disc member.

[0161] According to a yet further embodiment of the present invention, a disc prosthesis 502 is provided including two pairs of disc members, each pair including an upper disc member 504, 504' and a lower disc member 506, 506',

as shown in FIGS. 59a-59e. The disc members can include any or any combination of the abovementioned features and some of these features are labelled using the same reference labels as above. In addition, the vertebral endplate contact surface or superior surface 508, 508' of disc members 504, 504' are provided with a convex shaped portion 510, 510' thereon. The shape of the convex shaped portion is substantially complementary to the recess or concave shaped portion to provide an improved fit when the disc prosthesis is located with the vertebral body of an adjacent disc in use.

[0162] The height of the convex portion 510, 510' is greater towards the medial side 512 than to the lateral side 514. The longitudinal axis or longest length of the convex portion is along the anterior 516-posterior 518 axis. In addition, the convex portion is closer to the posterior end 518 of the disc than to the anterior end of the disc.

#### Facet Joint Replacement Prosthesis

[0163] Referring to FIGS. 31-52b, there is illustrated facet joint replacement prostheses 102, 202 according to embodiments of the present invention. Facet joint prostheses 102, 202 can be used alone, or in combination with the lumbar disc prosthesis described above to form a single unit system if the prostheses are designed to replace the entire facet joint on both the right and the left side of the vertebrae.

[0164] Prosthesis 102 includes a first member or male member 104 and a second member or female member 106. Both male and female members 104, 106 are substantially elongate in form. Male member 104 has a first end 108 with securing means in the form of an aperture 110 defined therein and a second end 112. End 108 is in the form of a flat or planar plate portion 113 and a curved arm portion 114 is provided between this plate portion 113 and end 112. Female member 106 has a first end 116 with securing means in the form of an aperture 118 defined therein and a second end 120. End 116 is in the form of a flat or plate portion 117 and a curved channel portion 122 is provided between this plate portion 117 and end 120.

[0165] The facet prosthesis 102 is inserted by removing the entire existing facet joint and placing pedicle screws 124 into the vertebral body above and below the disc. End 112 of male member 104 is inserted into end 120 of channel 122 of female member 106 and the ends of the pedicle screws 123 are threaded through apertures 118 and 110 and secured with a nut 126. The edge of plate portions 113 and 117 which define apertures 118 and 110 are tapered inwardly so as to allow a good fit with a tapered or conical shaped locking nut 126, as shown in FIG. 50. A further spacing or locking nut 127 can also be provided.

[0166] Male member 104 has a rear or posterior 128 and a front or anterior surface 130. The anterior surface 130 of arm portion 114 is typically substantially concave in shape and the posterior surface 128 of arm portion 114 is typically substantially convex in shape. As such, when member 104 is fitted to pedicle screw 124 in use, anterior surface 130 typically faces the vertebrae to which it is to be attached.

[0167] Female member 106 has a rear or posterior surface 132 and a front or anterior surface 134. The anterior surface 134 of channel portion 122 is typically substantially concave in shape and the posterior surface of channel portion 122 is typically substantially convex in shape. As such, when

member 106 is fitted to pedicel screw 124 in use, anterior surface 134 typically faces the vertebrae to which it is to be attached.

[0168] Thus, with the female member interconnected to the male member, the prosthesis curves outwardly from the vertebrae and outwardly of the plate portions 117 and 113. Arm portion 114 of male member 104 is freely slidable or movable in channel portion 122 of female member 106. The curvature of the male and female members is substantially the same. The male member 104 is of slightly smaller dimensions than the interior dimensions of channel portion 122, such that there is a small gap therebetween to allow some sideways movement, as shown by arrows 150 in FIG. 47, and rotation of the male member in the female member, as shown by arrows 152 in FIG. 46. The male member can also move longitudinally in the female member to allow flexion and extension of the prosthesis and thus the vertebral body, as shown by arrows 154 in FIGS. 45a and 45b.

[0169] End 120 of channel portion 122 has curved ends 136 and straight side walls 138 or side walls of less curvature than said curved ends to form a flattened oval shape, as shown in FIG. 49. Preferably side walls 138 form part of an arc, the radius of which is larger than for the arc of the curved ends 136. End 112 of arm portion 114 is substantially complementary in shape to end 120 having curved ends 140 and straight sidewalls 142 or side walls of less curvature than said curved ends. Preferably side walls 142 form part of an arc, the radius of which is larger than for the arc of the curved ends 140. The provision of the shaped ends allows a small degree of rotation of the male component in the female component.

[0170] The anterior surface 134 of channel portion 122 has a slot 144 provided longitudinally thereof. Slot 144 is of such a width that the channel portion encloses approximately 70% of the male member 104 when interconnected therewith and is provided to allow some lateral flexion and/or extension and rotation between the male and female members.

[0171] A left and right pair of facet joint prostheses are located between the disc on each side thereof. It is irrelevant whether the female or the male member is uppermost and thus the position of the members is interchangeable. In addition, the facet prosthesis can be used at two adjacent levels, and anchor into pedicle screws, as seen in FIGS. 48a-48d. A middle pedicle screw 124' can be used to accommodate two plate portions of the male and/or female members to form a stack. Any number of members can be attached to a pedicle screw as required.

[0172] The prosthesis can be formed from any suitable material, such as for example, stainless steel, ceramics, titanium, carbide or other suitable metal alloys. The surface of the prosthesis can be provided slightly roughened so as to increase bonding of the same with bone and/or one or more surface coatings can be provided thereon, such as for example, hydroxyapatite or plasma spray.

[0173] Referring to FIGS. 51-52b, prosthesis 202 is similar in appearance to prosthesis 102 and the same components are referred to in the two prostheses using the same reference numerals. However, in this embodiment, sliding or telescopic movement of male member 104 in channel portion 122 of female member 106 is limited firstly by locking

means in the form of a locking screw 204, and secondly by guide means in the form of enclosed slot 206 and pin 207.

[0174] The portion 208 adjacent end 112 of male member 104 is of smaller dimensions than the remaining portion 210 of male member 104 adjacent end 108. A shoulder portion 212 is created between portions 208, 210 and, with male member 104 in a fully retracted position as shown in FIG. 52a, end 120 of female member 106 can be located in abutting relationship with shoulder portion 212 or a small spaced distance apart.

[0175] Portion 208 of male member 104 is provided with a plurality of recesses 214 at spaced apart locations along an anterior surface thereof. An end of locking screw 204 located through an aperture provided on the posterior surface of female member 106 is typically located in one of these recesses 214 if the position of the male member with respect to the female member is required to be locked.

[0176] Telescopic or sliding movement between female member 106 and male member 104 can be limited via enclosed slot 206 provided on an posterior surface of female member 106 adjacent end 120. A pin 207 provided on an anterior surface of male member 104 adjacent end 112 thereof is slidably mounted in slot 206, thereby guiding movement of the male member with respect to the female member and preventing complete dissociation of the two members from each other.

[0177] A further difference between prosthesis 202 and prosthesis 102 is that ends 108 and 116 of male member 104 and female member 106 are substantially rounded and continuous in form. These ends can be attached to a clamp and pedicle screw to allow attachment of the same to the required vertebral bodies above and below the disc.

[0178] Referring to FIGS. 60a-61, there is illustrated a further embodiment of a facet joint prosthesis 600 according to the present invention. The prosthesis includes a male member 602 and a female member 604 which are similar in form to that described above and similar reference numerals are used to described corresponding parts. The difference of prosthesis 600 compared to the previously described embodiments are that the movement of male member 602 relative to female member 604 is limited by two clamping rings 606, 608. Thus, the clamping rings provide a clamping or compressive force around the two members when joined together to limit movement of the members relative to each other.

[0179] Clamping rings 606, 608 each have a sleeve portion 610 which is located around member 604, adjacent open ended slot 122 defined in said member 604. Plate members 612 protrude outwardly from the aperture 614 defined within sleeve portion 610 to define free ends of said clamping ring. The plate members 612 are a spaced distance apart and substantially parallel to each other. An aperture defined in each plate member allows a clamping screw 616 to be located therethrough so that a clamping force can be exerted via the clamping ring by tightening or loosening the screw.

[0180] A projection 618 is provided on an interior surface of sleeve portion 610 and said projection 618 is located in slot 122 in use to restrict movement of the clamping ring to sliding movement along slot 122.

[0181] The distance between clamping rings 606, 608 when located around female member determine the range of

movement of male member 602 relative to female member 604 by limiting movement of pin 207 on male member 602. Thus, the clamping rings allow the facet joint prosthesis to undergo micromotion when the rings are close together or full/greater movement when the clamping rings are a greater distance apart from each other. This flexibility in movement ensures greater versatility of the prosthesis and allows the same to be multi-functional.

[0182] A stop member 620 can also be inserted in the channel 622 defined in female member 602 to limit movement of male member 602 in said channel. The free end of male member 602 is substantially rounded.

[0183] Thus, it can be seen that in one aspect of the present invention, the two pairs of lumbar disc prosthesis and the two pairs of facet joint prosthesis can be used to form a system designed to allow an arthroplasty to be performed through the posterior route, allowing movement between the vertebral bodies as well as restoring stability between the two vertebral bodies by allowing normal load transmission across the disc, freeing up the neural structures and replacing the facet joints as well.

#### Lumbar and Cervical Disc Prostheses for Insertion Via an Anterior Route

[0184] Referring to FIGS. 53a-58f, there is illustrated lumbar and cervical disc prostheses 302, 402 respectively for insertion via an anterior route as a replacement for a diseased and/or damaged lumbar or cervical disc.

[0185] The disc prostheses 302, 402 include a pair of disc member having an upper disc member 304, 404 and a lower disc member 306, 406. The upper disc members include a vertebral endplate contacting surface or superior surface 308, 408 and an inferior surface 310, 410. The lower disc members include a superior surface 312, 412 and a vertebral endplate contacting surface or inferior surface 314, 414.

[0186] The disc prostheses for insertion via an anterior route are the same as the lumbar disc prostheses for insertion via a posterior route apart from the following differences.

[0187] The protrusion 316, 416 provided on the superior surfaces 312, 412 of the lower disc members 306, 406 is rugby ball shaped rather than domed shaped. Thus, the radius of the curve of the protrusion in the medial lateral plane 318, 418 is larger than the radius of the curve in the anterior posterior plane 320, 420.

[0188] In the cervical prosthesis, the protrusion 416 extends for substantially the entire width in the medial-lateral plane and the anterior-posterior plane of the disc prosthesis.

[0189] The inferior surface 310, 410 of the upper disc members 304, 404 is divided into three sections a middle section 322, 422 and two end sections 324, 424 and 326, 426. The boundaries of the sections are provided in the medial-lateral plane 318, 418. The superior surface 312 of the lower disc member 306 can also be divided into similar three sections in the lumbar disc prosthesis.

[0190] The recess portion 328, 428 is provided in the middle section 322, 422 as with the earlier embodiments. The recess portion 328, 428 is substantially curved and the curvature of the medial part 330, 430 of the recessed portion is substantially symmetrical to the curvature of the lateral

part 332, 432 (i.e. symmetrical about the midline). Thus, the lateral part 332, 432 has curvature corresponding to an arc of a circle which has a radius substantially equal to that of an arc of a circle corresponding to the curvature of the medial part 330, 430.

[0191] The radius of the curve of the recess portion 328, 428 is substantially equal to the radius of the curve of the protrusion 316, 416 in the medial-lateral plane 318.

[0192] Attachment means in the form of screws 334, 434 are provided adjacent an anterior edge 336, 436 of both the upper and lower disc prostheses. One screw is provided in the cervical prosthesis and two screws are provided in the lumbar prosthesis. Further attachment means in the form of spikes 338, 438 can be provided on the vertebral endplate contact surfaces to allow increased engagement with an adjacent vertebral disc member in use.

[0193] Lordosis is built into the prosthesis so that the anterior edge 336, 436 is larger in height than the posterior edge 338, 438.

What is claimed is:

1. A disc prosthesis, said disc prosthesis including a pair of disc members, the first member of said disc pair having a vertebral end plate contact surface and a recessed portion on an opposing surface thereof, the second member of said disc pair having a vertebral endplate contact surface and a protruding portion on an opposing surface thereof, the protruding portion of the second member engaging with the recessed portion of the first member in use, and wherein the inner or opposing surface of at least the first disc member is provided with at least three sections; a middle section and at least two end sections, the recessed portion being provided in the middle section and the thickness or depth of the middle section being less compared to the at least two end sections.

2. A disc prosthesis according to claim 1 wherein the recessed portion is substantially curved in form.

3. A disc prosthesis according to claim 1 wherein the end sections are substantially planar in form.

4. A disc prosthesis according to claim 1 wherein the inner or opposing surface of the second disc member is provided with at least three sections; a middle section and at least two end sections, the protruding portion being provided in the middle section of the disc member.

5. A disc prosthesis according to claim 1 wherein the boundaries of the middle and end sections are provided in the medial-lateral plane.

6. A disc prosthesis according to claim 1 wherein the boundaries of the middle and end sections are provided in the anterior-posterior plane.

7. A disc prosthesis according to claim 1 wherein the middle and end sections are arranged along substantially the entire length of the disc member.

8. A disc prosthesis according to claim 1 wherein the middle and end sections are arranged in a substantially central part of the disc member.

9. A disc prosthesis according to claim 1 wherein the vertebral endplate contact surface of the first and/or second members is provided with attachment means.

10. A disc prosthesis according to claim 9 wherein the attachment means includes any or any combination of one or more screws, one or more apertures for the location of screws, one or more tapered members, spikes or fins.

11. A disc prosthesis according to claims 1 wherein one or both of the end sections of the inner or opposing surfaces of the first and/or second disc members are provided at an acute angle to the horizontal.

12. A disc prosthesis according to claim 1 wherein the outer and/or inner surfaces of the second disc member form a narrowing taper towards one or both ends of the disc member.

13. A disc prosthesis according to claim 1 wherein one or both ends of the prosthesis has a narrowing taper towards the outer edges thereof.

14. A disc prosthesis according to claim 13 wherein the slope of the taper at the posterior end is opposite to the slope of the taper at the anterior end.

15. A disc prosthesis according to claim 1 wherein the height of the prosthesis at an anterior end of the disc is greater than the height of the prosthesis at a posterior end of the disc.

16. A disc prosthesis according to claim 1 which is provided for anterior insertion.

17. A disc prosthesis according to claim 1 which is provided for posterior insertion.

18. A disc prosthesis according to claim 16 wherein the protrusion portion of the second member is substantially the same shape and/or dimensions as the recessed portion of the first member.

19. A disc prosthesis according to claim 16 wherein the radius of the curvature of the protrusion portion in the medial to lateral plane is greater than the radius of the curvature of the protrusion portion in the anterior to posterior plane.

20. A disc prosthesis according to claim 16 wherein the protrusion portion in the medial to lateral plane is asymmetrical to the protrusion portion in the anterior to posterior plane.

21. A disc prosthesis according to claim 16 wherein the curvature of the medial part of the recessed portion is symmetrical to the curvature of the lateral part of the recessed portion.

22. A disc prosthesis according to claim 16 wherein a radius of the arc of the curvature of the recessed portion in the medial part thereof is substantially equal to the radius of the arc of the curvature of the recessed portion in the lateral part thereof.

23. A disc prosthesis according to claim 16 wherein the anterior part of the recessed portion is symmetrical to the posterior part of the recessed portion.

24. A disc prosthesis according to claim 16 wherein attachment means are provided adjacent an anterior edge thereof.

25. A disc prosthesis according to claim 16 wherein the prosthesis is in the form of a cervical or lumbar prosthesis.

26. A disc prosthesis according to claim 17 wherein the prosthesis is in the form of a lumbar or thoracic prosthesis.

27. A disc prosthesis according to claim 17 wherein attachment means are provided adjacent a posterior edge thereof.

28. A disc prosthesis according to claim 17 wherein two disc pairs are required to form the prosthesis.

29. A prosthesis according to claim 28 wherein the two pairs of disc member are mirror images of each other.

30. A prosthesis according to claim 28 wherein each pair of disc members is independently inserted into the disc space in the patient and is located on either side of the dural sac.

31. A prosthesis according to claim 17 wherein the recessed portion of the first member is substantially curved and the curvature of a medial part of said recessed portion is asymmetrical to the curvature of a lateral part of said recessed portion.

32. A prosthesis according to claim 17 wherein a lateral part of said recessed portion corresponds to an arc of a circle which has a radius greater than that of an arc of a circle corresponding to the curvature of a medial part of the recessed portion.

33. A prosthesis according to claim 17 wherein an anterior part of the recessed portion is substantially symmetrical to a posterior part of the recessed portion.

34. A prosthesis according to claim 17 wherein the recessed and protrusion portions in each disc member pair are asymmetrical.

35. A prosthesis according to claim 17 wherein the protrusion portion in a disc member pair makes contact with only a part of the recessed portion of said disc member pair.

36. A prosthesis according to claim 17 wherein the protrusion portion is symmetrical in the medial-lateral plane and the anterior-posterior plane but the curvature in the medial to lateral plane may be different to that in the anterior to posterior plane.

37. A prosthesis according to claim 17 wherein the protrusion portion is substantially dome shaped.

38. A prosthesis according to claim 17 wherein the recessed portion is substantially inverse dome shaped.

39. A prosthesis according to claim 17 wherein the attachment means includes one or more tapered members protruding outwardly of the vertebral endplate contact surface, the taper of said member narrowing from a posterior end towards an anterior end of the disc member.

40. A prosthesis according to claim 17 wherein the attachment means are provided towards a medial side of the first and/or second disc members.

41. A prosthesis according to claim 17 wherein the end sections of the opposing surface of said first disc member are mildly concave in form.

42. A prosthesis according to claim 1 wherein the middle section is located substantially centrally of said first and/or second disc members.

43. A prosthesis according to claim 17 wherein the middle and end sections each comprise at least one third of a disc member surface.

44. A prosthesis according to claim 1 wherein when one of the disc members moves towards an end of the prosthesis in extension or flexion, a gap between the end sections of the disc members increases at an opposite end of the prosthesis.

45. A prosthesis according to claim 1 wherein the vertebral endplate contact surface of the first member of said disc pair is provided with a convex shaped portion thereon.

46. A prosthesis according to claim 45 wherein the height of the vertebral endplate contact surface is greater towards a medial side of the first member.

47. A prosthesis according to claim 45 wherein a longitudinal axis of the convex shaped portion is substantially parallel to an anterior-posterior axis of the first member.

48. A prosthesis according to claim 45 wherein the convex shaped portion is provided closer to a posterior end of the first member than to an anterior end thereof.

49. A prosthesis according to claim 1 wherein said prosthesis is used in conjunction with a facet joint prosthesis.

50. A facet joint prosthesis according to claim 49 wherein a first member is provided for attachment to a first posterior lumbar disc in use and a second member is provided for attachment to a second posterior lumbar disc in use, and wherein at least a part of said first member is telescopically mounted in at least a part of said second member in use.

51. A facet joint prosthesis according to claim 49 wherein the first and/or second members are provided with or are associated with securing means for securing the members to a disc in use.

52. A facet joint prosthesis according to claim 51 wherein the securing means includes one or more pedicle screws.

53. A facet joint prosthesis according to claim 49 wherein the first member includes an elongate arm portion which is movably located in an elongate channel portion on said second member.

54. A facet joint prosthesis according to claim 53 wherein the arm portion and said channel portion are curved in form.

55. A facet joint prosthesis according to claim 53 wherein each of said arm portion and said channel portion communicate with a plate portion.

56. A facet joint prosthesis according to claim 53 wherein a slot is provided longitudinally of said channel portion.

57. A facet joint prosthesis according to claim 56 wherein said slot is of such a width to allow approximately 30% of the arm portion to be visible therethrough.

58. A facet joint prosthesis according to claim 56 wherein the slot is open ended.

59. A facet joint prosthesis according to claim 56 wherein an enclosed slot is provided on said channel portion and a pin provided on the elongate arm portion is slidably located therein.

60. A facet joint prosthesis according to claim 53 wherein the arm portion is of slightly smaller dimensions than the interior dimensions of said channel portion, such that a small gap is provided therebetween to allow some movement between said arm portion and said channel portion.

61. A facet joint prosthesis according to claim 53 wherein with the arm portion located in the channel portion, the arm portion can undergo limited rotation, side ways movement and sliding movement to allow flexion and extension with respect to said channel portion.

62. A facet joint prosthesis according to claim 53 wherein the end of the arm portion engaging in said channel portion has curved end walls and curved side walls, the curvature of said side walls being less than the curvature of said end walls.

63. A facet joint prosthesis according to claim 53 wherein the open end of the channel portion in which the arm portion engages has curved end walls and curved side walls, the curvature of said side walls being less than the curvature of said end walls.

64. A facet joint prosthesis according to claim 49 wherein the first and/or second members are provided with guide means for guiding or limiting relative movement between said first and second members.

65. A facet joint prosthesis according to claim 49 wherein the first and/or second members are provided with locking means for preventing relative movement between said first and second members.

66. A facet joint prosthesis according to claim 65 wherein the locking means is in the form of a locking screw.

67. A facet joint prosthesis according to claim 66 wherein the locking screw is located through an aperture defined in the second member and engages in one or more recesses provided in the first member.

68. A facet joint prosthesis according to claim 65 wherein the locking means includes one or more clamping rings.

69. A facet joint prosthesis according to claim 68 wherein one or more screws are used to clamp the clamping rings in a required position on the prosthesis.

70. A facet joint prosthesis according to claim 68 wherein two clamping rings are provided and the range of movement of the first and/or second members is determined by the distance between the two clamping rings on the prosthesis.

71. A facet joint prosthesis according to claim 68 wherein at least one projection on the interior surface of the clamping ring locates in a slot in the first and/or second member.

72. A facet joint prosthesis according to claim 53 wherein a stop member is located in the channel of the second member to limit movement of the first member in said channel and/or to act as a shock absorber.

73. A facet joint prosthesis according to claim 49 wherein a sleeve is provided over said prosthesis.

74. A facet joint prosthesis according to claim 49 wherein a pair of facet joint prostheses are used for each disc.

75. A facet joint prosthesis according to claim 49 wherein a plurality of first members can be attached to a second member and vice versa to form stacking of said prosthesis.

76. A prosthesis system, said system including a disc prosthesis and facet joint prosthesis as defined in claim 1.

77. A first disc member according to claim 1.

78. A second disc member according to claim 1.

79. A facet joint prosthesis, said facet joint prosthesis including a first member for attachment to a first posterior disc in use and a second member for attachment to a second posterior disc in use, and wherein at least a part of said first member is telescopically mounted in at least a part of said second member in use.

80. A method of attachment of a lumbar disc prosthesis in a patient, said lumbar disc prosthesis including a pair of disc members, a first member of said disc pair having a vertebral endplate contact surface and a recessed portion on an opposing surface thereof, a second member of said disc pair having a vertebral endplate contact surface and a protruding portion on an opposing surface thereof, the protruding portion of the second member engaging in the recessed portion of the first member in use, the prosthesis including a further pair of disc members, said further pair of disc members also including first and second members, said method including the steps inserting each pair of disc members via a posterior route.

81. A method of attachment of a facet joint prosthesis in a patient, said facet joint prosthesis including a first member and a second member, at least a part of said first member is telescopically mounted in at least a part of said second member in use, said method including attaching a part of said first member to one of an upper or lower vertebrae in

use posteriorly and attaching a part of said second member to the other of said upper or lower vertebrae in use posteriorly.

**82.** A lumbar disc prosthesis, said lumbar disc prosthesis including a pair of disc members, a first member of said disc pair having a vertebral endplate contact surface and a recessed portion on an opposing surface thereof, a second member of said disc pair having a vertebral endplate contact surface and a protruding portion on an opposing surface thereof, the protruding portion of the second member engaging in the recessed portion of the first member in use, and wherein the prosthesis includes a further pair of disc members, said further pair of disc members also including first and second members.

**83.** A lumbar disc prosthesis, said disc prosthesis including a pair of disc members, the first member of said disc pair having a vertebral endplate contact surface and a recessed portion on an opposing surface thereof, the second member of said disc pair having a vertebral endplate contact surface and a protruding portion on an opposing surface thereof, the protruding portion of the second member engaging with the

recessed portion of the first member in use, and wherein the vertebral endplate contact surface of said first member includes a convex shaped portion thereon.

**84.** A prosthesis system, said system including a disc prosthesis and facet joint prosthesis, said disc prosthesis including a pair of disc members, the first member of said disc pair having a vertebral end plate contact surface and a recessed portion on an opposing surface thereof, the second member of said disc pair having a vertebral endplate contact surface and a protruding portion on an opposing surface thereof, the protruding portion of the second member engaging with the recessed portion of the first member in use, said facet joint prosthesis including a first member for attachment to a first posterior lumbar disc in use and a second member is provided for attachment to a second posterior lumbar disc in use, and wherein at least a part of said first member is telescopically mounted in at least a part of said second member in use.

\* \* \* \* \*