

(19)



(11)

EP 2 343 247 A1

(12)

EUROPEAN PATENT APPLICATION

(43) Date of publication:
13.07.2011 Bulletin 2011/28

(51) Int Cl.:
B65D 85/804 (2006.01)

(21) Application number: **11157215.2**

(22) Date of filing: **21.04.2008**

(84) Designated Contracting States:
**AT BE BG CH CY CZ DE DK EE ES FI FR GB GR
HR HU IE IS IT LI LT LU LV MC MT NL NO PL PT
RO SE SI SK TR**

(72) Inventor: **Pineschi, Massimiliano
41010, VILLANOVA (IT)**

(74) Representative: **Modiano, Micaela Nadia
Modiano & Partners
Via Meravigli, 16
20123 Milano (IT)**

(30) Priority: **27.04.2007 IT MO20070143**

(62) Document number(s) of the earlier application(s) in
accordance with Art. 76 EPC:
08737493.0 / 2 152 609

Remarks:

This application was filed on 07-03-2011 as a
divisional application to the application mentioned
under INID code 62.

(71) Applicant: **Illycaffè' S.P.A.
34147 Trieste (IT)**

(54) **Capsule for containing doses of soluble drinks**

(57) Capsule (1) for containing doses (502) of soluble drinks comprising a container body (503) that shapes an inner containment cavity (513) for containing at least one dose (502) and which defines: an introductory opening (504) into said inner cavity (513) for a solvent liquid under pressure, dispensable using dispenser means (505), and seal closable using perforable closing means (509) with axial movement of said dispenser means (505); a bottom (506) having openable exit means (507) for the exit of dissolved drinks, characterised by the fact that it com-

prises opening means (520) arranged for opening said openable exit means (507) and cooperating with said dispenser means (505), wherein said opening means (520) can be operated with pressures generated in said inner cavity (513) by dispensing said solvent liquid under pressure dispensed by said dispenser means (505), wherein said openable exit means comprise: an opening (507) obtained in said bottom (506); a segment of flexible hose (561) fitted on an outer surface of said bottom (506) having a mouth communicating with said opening (507); and an opposite exit communicating with the outside.

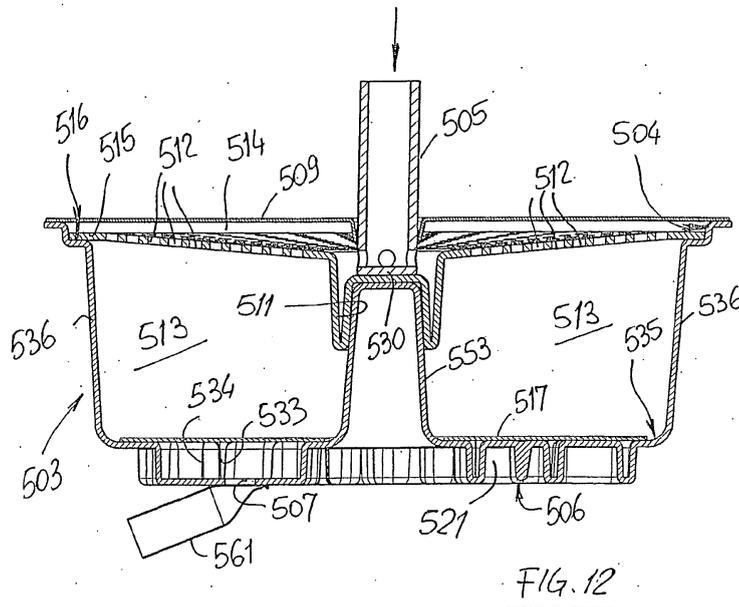

EP 2 343 247 A1

Description

TECHNOLOGICAL BACKGROUND

[0001] The invention refers to a capsule for containing doses of soluble drinks.

BACKGROUND ART

[0002] For some time now, the use has been known of automatic machines able to prepare and dispense soluble drinks.

[0003] These machines comprise a solvent-liquid tank, generally containing water, which is heated and which, at command, is sent, by means of a pump and through a conveyor pipe, towards an area in which a number of capsules are placed containing soluble substances in the form of powder which, mixed with the water, become drinks.

[0004] The capsules are permeable and the mixing with the soluble substances occurs inside them.

[0005] The machines are equipped with a dispensing device underneath which an area is contemplated where the containers for the dispensed drinks are placed, such as, e.g., disposable cups.

[0006] A capsule for containing soluble drinks is known by patent WO 2005/092160.

[0007] According to this patent, the capsule is composed of a lower cup portion forming a base with a dispensing mouth, and of an upper closing portion forming an inlet mouth for the solvent liquid. Between the lower portion and the upper portion a containment chamber is defined in which is placed a dose of a soluble substance in the form of powder.

[0008] The substance is contained between two transversal filtering elements placed in the containment chamber above and below the dose respectively and the lower filtering element forms a series of ribs in relief which are intended to penetrate in the dose of powder substance and which define a mandatory path for the substance when this is dissolved, so that the mix between the powdered component and the solvent liquid, meaning the water, is as complete as possible, before coming out of the dispensing mouth.

[0009] A further pod for containing soluble drinks is known by patent WO 2005/018395.

[0010] According to this patent, a pod is contemplated comprising a container body in which are defined two superimposed chambers.

[0011] The container body has an upper opening that is normally closed with a perforable diaphragm and an inner edge that delimits the two chambers and on which is fixed a second perforable diaphragm. Between the two diaphragms is contained a dose of soluble substance, while, below the second diaphragm, the second chamber is formed which is provided, at the lower extremity, with a dispensing mouth.

[0012] Between the lower face of the second dia-

phragm and the upper mouth of the second chamber connecting it to the first chamber, a filtering element is positioned having a series of tips turned towards the lower face of the second diaphragm.

[0013] Between the tips, transit holes are provided leading to a number of collection runs which, in turn, lead to a number of surrounding areas of the filtering element which have calibrated openings so as to only let the dissolved substance flow towards the lower chamber.

[0014] The water under pressure is introduced into the first upper chamber by means of an injector unit of a dispenser machine, which perforates the first diaphragm and dispenses water under pressure. Inside the first chamber, the pressure increases gradually and the second diaphragm is pushed onto the tips of the filtering element until this is perforated by these.

[0015] The soluble drink flows through the filtering element and is then collected inside the second lower chamber and, from this, is dispensed outside through the dispensing mouth, which is formed of a series of openings such as to control the speed of drink dispensing.

[0016] A further capsule for containing soluble substances is known by patent WO 2004/087529 A1 According to this patent, the capsule comprises a truncated-cone shaped body with an upper opening that is closed by means of a first sheet of plastic or aluminium material and which has a bottom wall with a section that re-enters the body.

[0017] Between the first sheet and the bottom wall, a first containment chamber is defined containing a dose of soluble substance.

[0018] This bottom wall forms a lower edge that delimits an opening with a width substantially the same as that of the body and which is also closed with a second sheet of plastic or aluminium material.

[0019] The bottom wall has a plurality of through holes and has a raised part at the centre which, underneath, has cylindrical ribs resting on the second sheet.

[0020] Between the bottom wall and the second sheet, a second chamber is defined underneath the first chamber.

[0021] The capsule is intended to be used in an automatic machine having an apparatus for injecting water under pressure.

[0022] This apparatus comprises an injector that perforates the first sheet, introduces water under pressure into the first chamber and then also perforates the second sheet.

[0023] The soluble substance dissolves inside the first chamber and collects in the second lower chamber, flowing through the holes obtained in the bottom wall and is therefore dispensed through the hole obtained in the second sheet.

[0024] Another capsule for containing soluble substances is known by the patent WO 2005/080223.

[0025] According to this patent, the capsule has a container body defining, inside, a containment chamber for containing a dose of soluble substance.

[0026] The container body has an upper opening that is sealed with a sheet of perforable material and a bottom defining a central area delimited by a predefined fracture line.

[0027] The capsule is used in drink dispenser machines having an injection unit that injects water under pressure into the containment chamber, after perforating the sheet of perforable material, and a presser unit designed to push on the central area so this fractures and returns inside the chamber, leaving the central area open so that, through this, the drink can flow out.

[0028] The presser unit has a part in contact with the central area and which has a predetermined section, so that, it too penetrating inside the, chamber to a small extent, a passage of desired and variable dimensions for the drink is defined between it and the edges of the opening defined by the removal of the central area.

[0029] A further capsule for containing soluble substances to make drinks is known by US patent 2006/0236871.

[0030] According to this patent, the capsule comprises a container body for containing a dose of soluble substance.

[0031] The container body is shaped like a glass and has the upper extremity opened which is sealed with a sheet of perforable material and the lower extremity that can be completely closed or open in the centre, but sealed with a lower diaphragm of perforable material; between the upper extremity and the lower extremity is defined a containment chamber for containing a dose of soluble substance.

[0032] Both in the upper extremity area and in the lower extremity area two respective selector elements are provided each of which consists of a flat body having through holes and which in the respective central area forms a recess towards the containment chamber: the two recesses obtained in the flat body of the selector elements are coaxial with each other.

[0033] On each flat body, filtering elements made of fabric are arranged intended to protect the through openings and which are sealed along the respective perimeters on the corresponding flat bodies so that, between these, the soluble substance does not filter.

[0034] The capsule is made to be fitted in a seat of an automatic dispenser machine, which has an upper injector of water under pressure which, after perforating the sheet of perforable material that closes the upper extremity, positions inside the upper recess without tearing it and introduces water inside the containment chamber to dissolve the soluble substance through the openings obtained in the upper selector element.

[0035] The dispenser machine also has a lower hollow tip which, when the pressure inside the containment chamber increases and the lower extremity of the glass-shaped body bends outwards, is designed to perforate this lower extremity or, in a further version of the capsule, to perforate the lower diaphragm, positioning in the corresponding recess, without tearing it.

[0036] The soluble drink flows through the openings obtained in the lower selector element and is dispensed outwards through an axial cavity on the lower tip.

[0037] A further embodiment of a pod for containing soluble substances is known by the patent WO 92/07775.

[0038] According to this patent, a pod is contemplated with a container body for containing a dose of a soluble substance.

[0039] The container body has a truncated-cone shape and is closed at the upper larger base by a convex wall outwards.

[0040] Similarly, the bottom of the container body is shaped like the upper convex wall and protrudes inside a containment chamber defined in the container body.

[0041] The latter has, substantially in a median area, a porous transversal diaphragm which is fixed around the perimeter of the inner wall of the container body.

[0042] The upper convex part has, centrally, a weakened area ready to be perforated by a perforating part fitted to a corresponding drink dispenser machine and which consists of an axially hollow needle which has ports for dispensing water under pressure which are positioned so as to direct water jets onto the inner face of the upper wall that then spring off this towards all the areas of the containment chamber, so that the water can be distributed in a substantially uniform way in all these areas.

[0043] The dispenser machine, besides the perforating part as previously mentioned, also has a receptacle inside which the capsule must be placed in order to be used.

[0044] This receptacle comprises a second container body that is open at the top and which has a substantially truncated-cone shape like that of the capsule, but slightly bigger so as to be able to contain it inside.

[0045] In turn, this second container body is housed in a collector device of the dispenser machine designed to collect the formed drink and convey this outside.

[0046] The bottom of this second container body has a series of perforators turned towards the bottom of the container body, which has a lower thickness than the walls, so that it can be easily perforated.

[0047] When the injector of the dispenser machine injects water under pressure inside the containment chamber, after perforating the upper wall, the pressure inside this chamber increases and the bottom wall bends outwards, entering into contact with the perforators of the second container body. These perforators are axially hollow and, when they penetrate inside the containment chamber where, after the injection of water the liquid mix has formed that produces a drink, they allow this mix to flow and this is dispensed outside after passing through a filter located in the collector device.

[0048] Another capsule for containing soluble substances to make ready drinks is known by the patent WO 2006/045536.

[0049] According to this patent, the capsule comprises a container body inside which is defined a containment chamber of a dose of soluble substance.

[0050] This container body has a perforable extremity and an opposite base extremity that is open, but which is sealed with a sheet of perforable material after the capsule has been filled with the soluble substance.

[0051] The dispenser machine that uses this capsule has a supporting element for supporting the base extremity of the capsule, or, more specifically, of the sheet of perforable material that is normally kept bent outwards, by injecting a small volume of suitable gas.

[0052] The supporting element has a plurality of perforator elements designed to perforate the sheet when the drink is required to be dispensed. The dispenser machine also comprises a bell-shaped body designed to couple up with the supporting element, superimposing itself on the capsule and which has, at the top of the inner wall, a perforator/injector linked with a dispensing channel of water under pressure and which is designed to inject water under pressure inside the containment chamber after perforating the perforable extremity.

[0053] The container body of the capsule also has a surrounding edge that can be seal locked between the supporting element and the bell-shaped body. When the dispensing is required of a drink inside the capsule, this is placed above the supporting element with the bell-shaped body in a position away from this to allow the positioning of the capsule.

[0054] Afterwards, a mechanism moves the bell-shaped body closer to the base element and the perforator/injector penetrates inside the containment chamber, injecting water under pressure into this.

[0055] Inside the containment chamber, the pressure gradually increases and the sheet of perforable material bends towards the perforator elements which perforate it.

[0056] Among the perforator elements drink collection channels are defined that convey the drink towards a dispensing mouth towards the outside.

[0057] This state of the art has a series of drawbacks.

[0058] A first drawback is that the known capsules have an extremely complicated structure and their fitting and filling is often difficult, as they are composed of several elements.

[0059] Another drawback is that, due to the structure of the known capsules, the distribution of water under pressure in the dose of soluble substance and, therefore mixing, lacks uniformity and, therefore, the quality of the dispensed drink is in some cases not acceptable due to the presence of undissolved residues of powdered substance.

[0060] A further drawback is that, due to this lack of uniform distribution of the water inside the dose of soluble substance, and of the consequent undissolved residues that have formed, the concentration of the substance in the drink is reduced and, therefore, the flavour is negatively altered.

[0061] A further drawback of the state of the art is that in many cases dispenser machines are needed that have a double device for perforating the capsules at both extremities, meaning to inject water under pressure and to

allow the exit and the dispensing of the formed drinks.

[0062] This requires the manufacture of machines with complicated and therefore very expensive structures, including with respect to the nature of the drinks to be dispensed which are generally very humble and which, therefore, require long manufacturing cost amortisation times.

OBJECTS OF THE INVENTION.

[0063] One object of the invention is to upgrade the state of the art.

[0064] Another object of the invention is to make a capsule for containing doses of soluble drinks that has a simplified structure, such as to allow the perfect distribution of solvent liquid, in this specific case, water, in the dose of soluble substance, so as to obtain a complete and uniform mix.

[0065] Another object of the invention is to make a capsule for containing doses of soluble drinks that is composed of the least possible number of component pieces, so as to be cheaper to manufacture compared to known capsules.

[0066] According to one aspect of the invention, a capsule is provided for containing doses of soluble drinks comprising a container body that shapes an inner containment cavity for containing at least one dose and which defines: an introductory opening into said inner cavity for a solvent liquid under pressure, dispensable using dispenser pipe means, and seal closable using perforable closing means with axial movement of said dispenser pipe means, a bottom having openable exit means for the exit of dissolved drinks, characterised by the fact that it comprises opening means arranged for opening said openable exit means and cooperating with said dispenser pipe means.

[0067] According to another aspect of the invention, a method is contemplated for the production of instant drinks comprising to prepare a containment capsule loaded with a dose of a powdered soluble drink; to introduce into said capsule a solvent liquid for dissolving said dose, to obtain a dispensing opening with perforator means in an area of said capsule so as to dispense a dissolved drink with said solvent liquid outside of said capsule, characterised by the fact that between said to introduce and said dissolving, to compress said dose inside said capsule is contemplated.

[0068] The capsule for containing doses of soluble drinks and the method for the production of soluble drinks therefore allow achieving a perfect and uniform mix of solvent liquid and the dose of soluble substance, by improving the concentration of the substance in the dispensed drink.

BRIEF DESCRIPTION OF THE DRAWINGS

[0069] Further characteristics and advantages of the invention will appear more evident from the detailed de-

scription of a capsule for containing doses of soluble drinks, illustrated indicatively by way of non limiting example in the accompanying drawings, wherein:

Figure 1 is a cross section view of a first embodiment of a capsule for containing doses of soluble drinks, in a closed configuration;

Figure 2 is a cross section view of the capsule of Figure 1 in an inlet configuration of a solvent liquid; Figure 3 is an exploded perspective view of the capsule of Figure 1 seen from above;

Figure 4 is an exploded perspective view of the capsule of Figure 1 seen from below;

Figure 5 is a cross section view of a second embodiment of a capsule for containing doses of soluble drinks, in a seal closed configuration;

Figure 6 is a cross section view of the capsule of Figure 5 in an inlet configuration of a solvent liquid; Figure 7 is an exploded and perspective view of the capsule of Figure 5;

Figure 8 is a cross interrupted section view of a third embodiment of a capsule for containing doses of soluble drinks, in a closed configuration;

Figure 9 is a cross section view of the capsule of Figure 8 in an inlet configuration of a solvent liquid; Figure 11 is an exploded and perspective view of the capsule of Figure 9,

Figure 111 is a cross section view of a fourth embodiment of a capsule for containing doses of soluble drinks, in a closed configuration;

Figure 12 is a cross interrupted section view of the capsule of Figure 11 in an inlet configuration of a solvent liquid;

Figure 13 is an exploded and perspective view of the capsule of Figure 11;

Figure 14 is a cross section view of a fifth embodiment of a capsule for containing doses of soluble drinks, in a closed configuration;

Figure 15 is a cross section view of the capsule of Figure 14 in an inlet configuration of a solvent liquid and dispensing configuration of a dissolved drink;

Figure 16 is an exploded view of the capsule of Figure 15.

EMBODIMENTS OF THE INVENTION.

[0070] With reference to the Figures from 1 to 4, it will be noticed that a capsule 1 for containing a dose 2 of soluble substance intended for the production of a soluble drink is composed of a container body 3, normally made of preformed plastic material and with a truncated-cone shape, which has, in what is considered an upper area, a larger base in which is obtained an opening 4 for introducing both the dose 2 into the container body 3, and a solvent liquid dispensed by dispenser means, normally made up of a rigid or substantially rigid pipe 5.

[0071] The container body 3 has a bottom 6, representing the smaller base of the container body 3, in which

can be obtained, as will be said later on, an exit port 7 through which is expelled, normally by gravity, a dissolved drink, obtained inside the capsule 1, by dissolving the dose 2 with a pre-determined volume of solvent liquid, in this specific case hot water under pressure, supplied by a pumping unit of an automatic dispenser machine and introduced into the container body 3 by means of a dispenser pipe 5.

[0072] Inside the container body 3, an inner cavity is defined, indicated by the reference 8, which is closed at the opening 4 by means of a sheet 9 of perforable material, normally Aluminium, but which could also be a sheet of polymer or paper material.

[0073] In this inner cavity 8, a first elastic diaphragm 10 is positioned which centrally forms a concave seat 11 that extends towards the inside of the inner cavity 8 and which has the closed extremity turned towards the bottom 6.

[0074] The first elastic diaphragm 10 has an annular surface surrounding the concave seat 11 which is crossed by a plurality of holes 12 that place in communication a solution chamber 13, defined between the first elastic diaphragm 10 and the bottom wall 6 and in which is placed the dose 2, with an adjacent chamber 14 for distributing the solvent liquid defined between the first elastic diaphragm 10 and the sheet 9 when this closes the opening 4.

[0075] The first elastic diaphragm 10 has its outer edge 15 resting on a supporting profile 16 obtained on the perimeter of the opening 4 and which keeps it in correct position, i.e., centred inside the solution chamber 13, and is designed to bend in axial direction towards the bottom 6.

[0076] In the solution chamber 13 is also arranged a second permeable diaphragm 17 between the first diaphragm 10 and the bottom 6 and which can also be flexible in axial direction: the central axes of the first diaphragm 10 and of the second diaphragm 17 are substantially common to both and coincide with each other.

[0077] As can again be seen in the Figures from 1 to 4, the second diaphragm 17 defines, between it and the bottom 6, a further chamber 21 for collecting the dissolved drinks, before these are expelled outside and also forms a neck 18 that is centred and extends towards the concave seat 11.

[0078] The neck 18 has a diameter slightly larger than the outer diameter of the seat 11 and is designed to receive the latter inside it when the first diaphragm 10 bends towards the bottom 6.

[0079] On its outer wall, the concave seat 11 forms a collar 19 in relief towards the outside that is meant to rest on the mouth of the neck 18, so as to transmit an axial flexion of the first diaphragm 10 to the second diaphragm 17.

[0080] The latter, in a first version of the capsule 1, forms, on the opposite side to the neck 18, a perforator 20 intended to perforate the bottom 6 when the second diaphragm 17 bends towards the bottom 6, pushed in

turn by the flexion of the first diaphragm 10.

[0081] This perforator 20, which in this version of the capsule 1 is obtained in a single piece with the second diaphragm 17, comprises, as can be seen in the Figures 1 and 2, and in the Figure 8 in enlarged scale, a substantially cylindrical body 23 which axially has a cavity 22 inside which is arranged, or obtained, a second pipe element 24 coaxial with the body 23 and which has a smaller diameter than this, so as to define between them an annular chamber 25.

[0082] The second pipe element 24 is connected by an inner extremity to the body 23 by means of an annular lip 26 so as to be, as said, a single piece with this and has an axial cavity 27 that has one open extremity turned outwards while the opposite extremity runs into a small chamber 28 obtained in a coupling area of the perforator 20 to the neck 18.

[0083] The small chamber 28 has a series of openings 29 that run into the further collection chamber 21 and which place the latter in communication with the outside when the second diaphragm 17 is bent towards the bottom 6 and the perforator element 20 has perforated it, as can be seen in the Figure 2. The edge 30 of the outward turned extremity of the perforator 20 is sharp and has an oblique pattern to create a sort of slanting tip that favours perforation of the bottom 6.

[0084] In the perimeter wall of the pipe element 24 a port 31 is also obtained that places in communication the axial cavity 27 of the pipe element 24 and the annular chamber 25.

[0085] The second diaphragm 17 also has a surface in which are obtained transit openings 32 to allow the dissolved drinks in the solution chamber 13 to flow into the collection chamber 21.

[0086] As can be seen in the Figure 2, the rigid pipe 5, which is part of a machine for dispensing soluble drinks and which has the dual function of perforating the sheet 9 and dispensing hot water under pressure, has expulsion holes 33 that are obtained in the side wall of the rigid pipe 5, at a pre-set distance from the perforating extremity, indicated by 134 and closed; by the expression pre-set distance is meant a distance that allows the water under pressure to be dispensed inside the solution chamber 13: consequently, when the rigid pipe 5 has fully penetrated inside the concave seat 11, the expulsion holes 33 are positioned beyond the perforated sheet 9, as can again be seen in the Figure 2.

[0087] When the second diaphragm 17 is fully bent, it rests on the bottom 6; it must be pointed out that the outer edge of the second diaphragm 17 is shaped according to a convex profile 34 that couples with a concave counter-profile 35 obtained in the container body where the side wall of this, indicated by 36, couples with the bottom 6. It must also be said that on the second diaphragm element 17 a filter 37 can be fitted to filter the dissolved drinks that flow towards the collection chamber 21, in such a way that no undissolved drink particles reach this.

[0088] In a second version of the capsule 1, shown in

the Figures 5, 6, 7, it will be noticed that the first diaphragm 10 still has the collar in relief 19 obtained outside the concave seat 11 that is in contact with the neck 18, while the second diaphragm, indicated by 117, forms a central seat 38, that can be cylindrical or slightly conical, in which is located, in an axially sliding way, the perforator, indicated in this case by 120, which, in the case of the central seat 38 being slightly conical, engages with this during sliding.

[0089] In other words, the concave seat 11 still rests directly on the neck 18, but in this case, the first diaphragm 10 does not bend towards the bottom 6. The dispenser pipe 5, in crossing the concave seat 11 directly pushes the perforator 120 towards the bottom 6 so as to perforate it, as can be seen in Figure 6.

[0090] In this second version of the capsule 1, the second diaphragm 117 may also not be flexible; nevertheless, as in the previous version, it has a multiplicity of openings 132 which cross it to allow the dissolved drinks to flow from the solution chamber 13 to the collection chamber 21, before being expelled towards the outside through a series of openings 129, that are obtained transversally in the perforator 120, and an axial cavity 127 of this, which, therefore, has a structure substantially the same as that of the perforator 20 described previously, but which is not made in a single piece with the second diaphragm 117, but is guided sliding inside the neck 18.

[0091] In this second version of the capsule 1, the use is also contemplated of a filter 37 resting on the surface of the second diaphragm 117, to prevent the transit of undissolved drink particles into the collection chamber 21.

[0092] With reference to the Figures 8, 9, 10, a third version of the capsule 1 can be seen.

[0093] This third version also has a container body 403 comprising a side wall 436 and a bottom 406 to which this is coupled.

[0094] The side wall 436 defines, on the opposite side to the bottom 406, an opening 404 for the introduction of a dose 402 of a powdered drink contained in a mixing chamber 413 defined inside the container body 403.

[0095] In this fourth version of the capsule 1, the opening 404 is also closable with a sheet 409 perforable by an extremity of a dispenser pipe 405 fitted on a soluble drink dispenser machine of known type and able to move between an idle position distant from the capsule 1 to a dispensing position of hot water under pressure in which after perforating the sheet 409, it penetrates the capsule 1 and dispenses the hot water under pressure required to dissolve the dose 402 of the powdered drink.

[0096] In this third version of the capsule 1, the container body 403 forms a concave seat 411 obtained eccentrically with respect to the mixing chamber 413 and which is intended, as in the previously described versions, to receive inside it the perforating extremity of the dispenser pipe 405, after this has perforated the sheet 409.

[0097] Between this and the concave seat 411 a pas-

sage 414 remains defined through which the dispensed water reaches the inside of the mixing chamber 413 which has an annular pattern.

[0098] The sheet 409 which, in this case is preformed, has a portion 410 that is folded to form a bend that extends inside the mixing chamber 413, so as to form inside this with the wall 436 a mandatory path for the dispensed water, which develops by penetrating inside the dose 402.

[0099] The wall 436 of the container body 403, in turn forms a portion 453 which is raised off the bottom 406 and which shapes, as said, the annular pattern of the mixing chamber 413.

[0100] This portion 453 extends towards the sheet 409 for a pre-determined section so as to form, with this, a further passage 432 for the dissolved drink which is conveyed into a collection chamber 421 defined centrally concentric to the mixing chamber 413.

[0101] Inside the collection chamber 421 is arranged, in a sliding and guided way, a perforator 420 which axially features a duct 427 which is open at both extremities.

[0102] This perforator 420 is intended to perforate the bottom 406 by means of an extremity 430 turned towards this dispensing a dissolved drink through the duct 427.

[0103] In this third version of the capsule 1, the bottom 406 can contemplate, as can be seen in the Figures 8 and 9, an opening 407 already defined and kept normally closed with a further perforable sheet 460 fitted in an adherent way on the outer face of the bottom 406.

[0104] It should be noticed that between the mixing chamber 413 and the collection chamber 421 an annular concave area 463 remains defined intended to receive inside it a supporting collar indicated by 464 in the Figure 14 and equipping the housing seat of the capsule 1 of a soluble drink dispensing machine.

[0105] On the extremity 431 of the perforator 420 opposite the extremity 430, is located a filter 437 for filtering the dissolved drinks and preventing undissolved particles of a dose 402 from flowing into the duct 427.

[0106] With reference to the Figures 11, 12, 13, a fourth version of the capsule 1 will be seen.

[0107] According to this fourth version, the capsule 1 has a container body 503 that comprises an outer wall 536, a bottom 506 and an opening 504, defined on the opposite side of the bottom 506, for the introduction of a dose 502 of a powdered drink, which is contained in a solution chamber 513 in turn defined inside the container body 503.

[0108] The opening 504 is seal closable by means of a perforable sheet 509, made, e.g., of Aluminium, which is fastened in an adherent way to a surround of the opening 504, e.g., by means of an adhesive material.

[0109] Furthermore, the opening 504 forms an inner supporting profile 516 on which rests an outer edge 515 of a first diaphragm 510, kept in position centred inside the solution chamber 513. Between the sheet 509 and the first diaphragm 510 is defined a distribution chamber 514 adjacent to the solution chamber 513 and placed in

communication with this by means of a plurality of holes 512 obtained in the diaphragm 510. Centrally, the latter form a concave seat 511 in which is meant to be received an extremity 530 of a dispenser pipe 505 equipping a soluble drink dispenser machine and designed to dispense hot water under pressure after perforating the sheet 509 and having penetrated inside the concave seat 511.

[0110] As can be seen in the Figures 11 and 12, the solution chamber is annular and centrally the bottom 506 has a raised portion 553 that develops inside the solution chamber 513, acting as a central support for the concave seat 512 of the first diaphragm 510.

[0111] The bottom 506 of the container body 503 is shaped so as to form a supporting edge 535 for a second annular diaphragm 517 which, with the bottom 506, forms a collection chamber 521, inside which a dissolved drink is collected before being dispensed.

[0112] The second diaphragm 517 is crossed by a plurality of holes (not visible) which place the solution chamber 513 in communication with the collection chamber 521.

[0113] Inside the latter some walls 533 and 534 are arranged, as shown in the Figure 20, designed to create a labyrinth in which a dissolved drink is forced to flow before being dispensed outside, so as, by means of this flowing through the labyrinth, to improve the dissolved drink mix.

[0114] The shape and dimensions of the walls 533 and 534 can be any and defined by specific requirement.

[0115] The bottom 506 has an opening 507 already defined and protectable by fitting to an outer face of the bottom 506 a further adhesive sheet 560 that forms a flexible hose 561 axially hollow and normally bent towards the outer face of the bottom 506 so as to seal-close the opening 507 when no dissolved drink has to be dispensed.

[0116] According to a fifth version of the capsule 1 shown in the Figures 14, 15, 16, it will be noticed that this again comprises a container body 703 which is composed of a bottom 706 and a side wall 736 which defines, within, an inner cavity 708 in which a solution chamber 713 is obtained. The inner cavity 708 defines an opening 704 opposite the bottom 706 that allows introducing a dose of powdered soluble drink into the solution chamber 713.

[0117] The container body 703 also shapes an inlet 737 shaped like a tray 714, arranged eccentrically with respect to the solution chamber 713, but connected to this through a passage 732.

[0118] The inlet 737 is meant to receive inside it the extremity of a dispenser pipe 705 normally fitted on a soluble drink dispenser machine and which, as already previously said, is moving between an idle position and a dispenser position in which introduction is made into the inlet 737.

[0119] The opening 704 and the inlet 737 are both closable by means of a shaped and thin lid 709, which is

made of perforable material, in such a way as to allow the dispenser pipe 705 to cross it to reach the tray-shaped inlet 714.

[0120] The lid 709, in detail, centrally shapes a hollow seat 711 and a folded annular portion 710 that extends inside the solution chamber 713, penetrating the dose of soluble powdered drink and forming with the wall 736 a forced path for the hot water under pressure dispensed from the dispenser pipe 705, so that this reaches all the dose areas, making the solution of this substantially complete.

[0121] As can be seen in the Figures 22 and 23, the bottom 706 has a portion 753 that extends centred towards the inside of the solution chamber 713, at the hollow seat 711.

[0122] The latter is ready to receive inside it a pusher member 770 that is connected to the dispenser pipe 705 which is mobile with this, as schematically shown with the connection bar 771.

[0123] This pusher member 770 is meant to press on the blind bottom of the hollow seat 711, indicated by 772, causing the lid 709 to bend in the direction of the bottom 706 when the dispenser pipe 705 penetrates the tray 714.

[0124] Again with reference to the Figures 15 and 16, it will be noticed that the portion 753 defines inside it a substantially cylindrical seat 754 that is centred in the solution chamber 713 and which has a mouth 755 and an opposite bottom base 756 in which is defined an opening 757, normally closed by a sheet 758 of perforable material.

[0125] On the mouth 755 is arranged a filter 759 with predetermined porosity to prevent undissolved particles of a drink dose from being dispensed outside.

[0126] In the seat 754 is arranged sliding a perforator 720 having an extremity turned towards the filter 759 and an opposite extremity turned towards the opening 757 and designed to perforate the sheet 758 when, in a dissolved-drink dispensing condition, the perforator 720 is pushed by the blind bottom 772 of the hollow seat 711, in turn pushed by the pusher member 770.

[0127] The perforator 720 axially has a transit channel 721 which, when the sheet 758 is perforated, places the solution chamber 713 in communication with the outside, through the filter 759 that protects the inlet of the hollow seat 711.

[0128] The operation of the capsule 1 is described below, making reference from time to time to all the previously described embodiment versions. According to the first version of the capsule 1 for containing doses of soluble drinks, the capsule 1 is positioned inside a specifically provided seat in a conventional soluble drink dispenser machine, which has a rigid pipe 5 for dispensing hot water under pressure that can be moved between an idle position away from the seat and a dispensing position close to the seat, as will be indicated below.

[0129] The capsule 1 is prepared by inserting inside it, precisely inside the inner cavity 8 through the opening 4, a dose of a soluble powdered drink, in this specific case,

by way of example, coffee, but which could be any other soluble substance, such as, e.g., tea, camomile, herbal teas.

[0130] The opening 4 is then sealed by means of a sheet 9, preferably made of aluminium and perforable by means of the rigid pipe 5.

[0131] When the capsule 1 is placed by a consumer into the seat of the dispenser machine and this is started to dispense coffee, the rigid pipe 5, which normally lies in the distanced position, moves in the direction of the capsule 1 perforating the sheet 9 and the dispensing of hot water under pressure begins which, in this case is the solvent liquid.

[0132] The dispensed water spreads over the first elastic diaphragm 10, between this and the residual part of the sheet 9, meaning in the distribution chamber 14, and penetrates into the solution chamber 13 through the holes 12 which are distributed in such a way that the water is able to reach all the areas of the solution chamber 13 and therefore dissolve, in a complete way, all the dose of powdered drink contained in this.

[0133] While the dispensing of hot water under pressure continues, the rigid pipe 5 continues to move towards the bottom 6 of the capsule 1, guided in the concave seat 11 and resting on the bottom of this.

[0134] The dissolved coffee gradually collects in the collection chamber 21, passing through the transit openings 32.

[0135] The rigid pipe 5 continues to move, causing the first diaphragm 10 to deform elastically in the direction of the bottom 6: this way, the first diaphragm 10 gradually compresses the dose of coffee contained in the solution chamber 13. Because the first diaphragm 10 is placed in contact with the second diaphragm 17 by means of the collar 19 which is resting on the neck 18 obtained in this, the second diaphragm also bends in the direction of the bottom 6 of the capsule 1. The movement of the second diaphragm 17 causes the perforation of the bottom 6, as can be seen in the Figure 2, by means of the perforator 20 which, in this first version of the capsule 1, is obtained in just one piece with the second diaphragm 17. The movement of the perforator 20 towards outside of the capsule 1 results in the series of openings 29 obtained in this moving towards the bottom 6, allowing the flow of the dissolved coffee towards the outside, placing the collection chamber 21 in communication with the outside through the axial cavity 27 obtained in the perforator 20 and, therefore, allowing the dispensing towards the consumer.

[0136] During the flow of the dissolved coffee in the axial cavity 27, a quantity of air is sucked from outside through the cavity 22 that surrounds the axial cavity 27 and the port 31 and is mixed with the dissolved coffee during dispensing.

[0137] This way, the dissolved coffee is enriched with air during dispensing and forms a pleasant cream on the surface of the dispensed coffee that deposits in a container underneath the edge 30 of the dispenser 20.

[0138] The filter 37 arranged in the surface of the first diaphragm 10 protects the holes 12 from the transit of undissolved particles of coffee, and prevents these first of all depositing in the collection chamber 21 and then being dispensed towards the outside, falling into the container from which the consumer drinks.

[0139] The outer edge of the second diaphragm 17 has a profile 34 shaped so as to seal-couple with the counter-profile 35 of the container body 3 of the capsule 1, the side wall 36 of which connects with the bottom 6, so as to prevent the infiltration in this area too of undissolved particles between the solution chamber 13 and the collection chamber 21. The exit port 7 can be shaped like an opening obtained in the bottom 6 and subsequently closed with a further perforable sheet, or it can be obtained in the bottom 6 as a pre-fracturing contour obtained in the latter.

[0140] According to the second version of the capsule 1 for containing doses of soluble drinks illustrated in the Figures 5, 6, 7, it will be noticed that the perforator 120 is no longer obtained in just one piece with the second diaphragm 117, but is separate from this and arranged in a sliding way, guided in a central seat 38, cylindrical or slightly conical, that tightens towards the bottom 6, obtained in the latter and pushed by the bottom of the hollow seat 11 when the dispenser pipe 5 penetrates in this, pushing it towards the bottom 106 while dispensing hot water under pressure.

[0141] In this second version of the capsule 1 as well, the dispensed hot water is first of all collected in the distribution chamber 14, from where it passes into the solution chamber 13 through the holes 12 obtained in the first diaphragm 10, the outer perimeter edge 15 of which rests on the supporting profile 16 of the container body 3. Nevertheless, in actual fact, the operation of this second version of the capsule 1 is substantially similar to that of the previous first version.

[0142] The hot water dispensed from the dispenser pipe 5, after this has perforated the sheet 9, dissolves the dose 2 of coffee contained inside the solution chamber 13.

[0143] The dissolved coffee gradually flows into the collection chamber 21 through the multiplicity of openings 132 obtained in the second diaphragm 117 and protected by a filter 37 that prevents any undissolved coffee particles from transiting through the collection chamber 21.

[0144] In this second version of the capsule 1, the dispenser pipe 5 presses directly on the perforator 120 which, pushed in the direction of the bottom 6, perforates it slipping towards the outside.

[0145] At the same time, the movement of the perforator 120 places the collection chamber 21 in communication with the outside, permitting the dispensing of the dissolved coffee through the series of openings 129 and the axial cavity 127.

[0146] In this second version, the flexion is not contemplated of the first diaphragm 10 and of the second diaphragm 117, which in this case too rests with the con-

vey profile 34 of the outer edge on the concave counter-profile 35 obtained in the container body 3 in the connection point between the bottom 6 and the side wall 36.

[0147] In the third version of the capsule 1, the perforator pipe 5 perforates the sheet 409 which in this case is shaped and not completely flat, which closes the container body 403 and which can be shaped like a thin perforable lid made by pressing a laminar sheet of food-safe plastic material.

[0148] The dispenser pipe 5 penetrates inside the concave seat 411 which, in this version of the capsule 1, is eccentrically obtained with respect to the solution chamber 413 and dispenses water under pressure that follows the path indicated by the arrows "F", forced by the bent portion 410 which penetrates inside the dose 2 of coffee contained in the solution chamber 413.

[0149] The path is deliberately winding and is also formed of the portion 453 raised with respect to the bottom 406; this way, the hot water under pressure is distributed in a substantially uniform way inside the solution chamber 413 which, in this fourth version of the capsule 1, has a generally annular shape.

[0150] Centrally, the raised portion 453 defines the collection chamber 421 in which flows the perforator 420 which is axially covered by the duct 427 the inlet of which, as can be seen in the Figure 11 or 12, is protected by a filter 437 which has predetermined porosity so as to create a difference in pressure between the solution chamber 413 and the collection chamber 421 which increases along with the increase in the water dispensed inside the solution chamber 413.

[0151] When this pressure difference reaches a preset value, the force that pushes on the filter 437 causes the perforator 420 to move in the direction of the bottom 406 until this is perforated, placing the collection chamber 421 in communication with the outside and allowing the dispensing of the dissolved coffee.

[0152] The possibility exists that in the concave area 463 defined by the raised portion 453, a supporting collar 464 be accommodated specially provided in the automatic dispenser machine to support the capsule 1 in the correct position during the perforation of the sheet 409 and the dispensing of the coffee.

[0153] With reference to the fourth version of the capsule 1 shown in the Figures 11, 12, 13, it will be seen that the dispenser pipe 505 perforates the sheet 509, penetrating into the concave seat 511 defined in the first diaphragm 510 and dispensing hot water under pressure.

[0154] This dispensed hot water is collected in the distribution chamber 514 and from here it is distributed into the solution chamber 513 through the plurality of holes 512 obtained in the first diaphragm 510.

[0155] The solution chamber 513 is of annular shape and the bottom 506 has, centrally, a raised portion 553 that also acts as a stop element for the dispenser pipe 520.

[0156] The dissolved coffee is collected in the collection chamber 521 after passing through the plurality of

holes obtained in the second diaphragm 517 and is forced to complete a winding path between the interstices defined between the walls 533 and 534: this path improves the mixing of the water and the dose of coffee.

[0157] When the pressure inside the container body 503 reaches a pre-set value, the flexible hose 561 of the sheet 560 detaches from this and bends towards the outside, opening the opening 507 and placing the collection chamber 521 in communication with the outside and allowing the dispensing of dissolved coffee through the flexible hose 561 which, for this reason, is axially hollow.

[0158] In the fifth version of the capsule 1, the lid 709 is perforated by a dispenser pipe 705 which penetrates into the inlet 736 arranged eccentrically and which is moving together with a pusher member 770 to which it is mechanically linked, e.g., in a schematic way, by means of the connection bar 771.

[0159] The latter is introduced at the same time into the hollow seat 711 causing the lid 709 to bend towards the bottom 706 and the perforator 720 to slide inside the seat 754 until it perforates the bottom 796, placing the transit channel 721 in communication with the outside.

[0160] The hot water under pressure dispensed by the dispenser pipe 705 follows the path defined in the solution chamber 713 by the folded portion 710 and by the portion 753 which lifts off the bottom 706, dissolving all the dose of coffee contained in the solution chamber 713.

[0161] The dissolved coffee flows through the filter 759 protecting the inlet of the seat 754 and is dispensed outside through the transit channel 721. When pushed towards the bottom 706, the perforator 720 perforates the sheet 758 which hermetically seals the opening 757 in the bottom 706.

[0162] The present disclosure concerns:

- 1) Capsule (1) for containing doses (2; 402; 502) of soluble drinks comprising a container body (3; 403; 503; 736) that shapes an inner containment cavity (8; 708) for containing at least one dose (2; 402; 502) and which defines: an introductory opening (4; 404; 504; 704) into said inner cavity (8; 708) for a solvent liquid under pressure, dispensable using dispenser means (5; 405; 505; 705), and seal closable using perforable closing means (9; 409; 509; 709) with axial movement of said dispenser means (5; 405; 505; 705); a bottom (6; 406; 506; 706) having openable exit means (7; 407; 507; 758) for the exit of dissolved drinks, characterised by the fact that it comprises opening means (20; 420; 520; 720) arranged for opening said openable exit means (7; 407; 507; 758) and cooperating with said dispenser means (5; 405; 505; 705).
- 2) Capsule according to point 1, wherein said dispenser means comprise a substantially rigid dispenser pipe (5; 405; 505; 705), associated in a mobile way to a dispenser machine between an idle position and a perforation and dispensing position.
- 3) Capsule according to point 1, wherein said open-

ing means (20; 420; 520; 720) can be operated with pushes of said dispenser pipe means (5; 405; 505; 705).

4) Capsule according to point 1, wherein said opening means (20; 420; 520; 720) can be operated with pressures generated in said inner cavity (8; 708) by dispensing said solvent liquid under pressure dispensed by said dispenser means (5; 405; 505; 705).

5) Capsule according to point 2, wherein said opening means (20; 420; 520; 720) are arranged in said inner cavity (8; 708) substantially aligned with said dispenser pipe (5; 405; 505; 705) and in a sliding way between a withheld position inside said inner cavity (8; 708) and an exit position of dissolved drinks, protruded outside said inner cavity beyond said bottom (6; 406; 506; 706).

6) Capsule according to point 1, wherein in said inner cavity (8; 708) are arranged separator means (10; 410; 510) defining an inlet chamber (14; 411; 514; 714) for said fluid under pressure and an adjacent solution chamber (13; 413; 513; 713) for said at least one dose with said solvent liquid under pressure.

7) Capsule according to point 6, wherein said inlet chamber (14; 411; 514; 714) is defined in an eccentric position with respect to said solution chamber (13; 413; 513; 713).

8) Capsule according to point 6, wherein said inlet chamber (14; 411; 514; 714) is defined in a substantially aligned position extending from said solution chamber (13; 313; 413; 513; 613; 713).

9) Capsule according to point 6, wherein said separator means (10; 410; 510) comprise passage means (12; 414 ; 512; 732) of said liquid under pressure dispensed between said inlet chamber (14; 411; 514; 714) and said solution chamber (13; 413; 513; 713).

10) Capsule according to point 6, wherein said separator means comprise a first diaphragm (10; 410; 510) which can be arranged in said inner cavity (8; 708) substantially parallel with said introduction opening (4; 404; 504; 704).

11) Capsule according to point 2 or 10, wherein said first diaphragm (10; 410; 510) shapes a concave seat (11; 411; 511; 711) that extends towards said bottom (6; 406; 506; 706) and arranged for receiving fitted inside said dispenser pipe (5; 405; 505; 705) in a perforated position of said closing means (9; 409; 509; 709) and in a dispensing position of said solvent liquid under pressure.

12) Capsule according to point 1 or 11, wherein said concave seat (11; 411; 511; 711) protrudes resting onto said opening means (20; 420; 520; 720).

13) Capsule according to point 1, or 11 or 12, wherein said first diaphragm (10; 410; 510) is flexible towards said opening means (20; 420; 520; 720) in such a way that in a bent configuration, said concave seat (11; 411; 511; 711) pushes said opening means (20; 420; 520; 720) to open said openable means (7; 407; 507; 758).

14) Capsule according to point 11 or 13, wherein said bent configuration occurs when said dispenser pipe (5; 405; 505; 705) penetrates said concave seat (11; 411; 511; 711) fitting inside it with a perforation movement of said closing means (9; 409; 509; 709) and a dispensing movement of said solvent liquid under pressure.

15) Capsule according to point 9 or 10, wherein said passage means comprise a plurality of through holes (12; 414; 512; 732) obtained in said first diaphragm (10; 410; 510) and distributed in such a way that said solvent liquid under pressure is distributed in all said at least one dose.

16) Capsule according to point 1, wherein said inner cavity (8; 708) has a shape chosen between cylindrical and truncated-cone with the smaller base defining said bottom (6; 406; 506; 706).

17) Capsule according to any of the points from 1 to 16, wherein said first diaphragm (10; 410; 510) is circular and said hollow seat (8; 708) is obtained in a substantially centred position.

18) Capsule according to point 1 or 12, wherein said opening means comprise a perforator element (20; 420; 520; 720) that defines a perforation extremity turned towards said bottom (6; 406; 506; 706) and an opposite extremity in contact with said concave seat (11; 411; 511; 711).

19) capsule according to point 5 or 18, wherein said perforator element (20; 420; 520; 720) can be axially moved between said withholding position and said exit position, guided with guide means (38; 453; 737).

20) Capsule according to point 19, wherein said guide means comprise a second permeable diaphragm (17; 517) arranged in said inner cavity (8; 708) and defining a centred opening having guide edges (18; 38; 754) of said perforator element (20; 420; 520; 720).

21) Capsule according to point 19 or 20, wherein said perforator element (20; 420; 520; 720) and said second permeable diaphragm (17; 517) are made in a single piece.

22) Capsule according to point 21, wherein said second permeable diaphragm (17; 517) is flexible towards said bottom (6; 406; 506; 706).

23) Capsule according to point 20, wherein said second permeable diaphragm (17; 517) defines in said solution chamber a third collection chamber (21; 421; 521; 754) of dissolved drinks comprised between said second diaphragm and said bottom (6; 406; 506; 706).

24) Capsule according to point 20 or 23, wherein said second permeable diaphragm (17; 517) comprises a plurality of transit holes (32) for said dissolved drinks from said solution chamber (13; 413; 513; 713) to said collection chamber (21; 421; 521; 754).

25) Capsule according to point 18, wherein in said

5

perforator element (20; 420; 520; 720) are obtained: an exit channel (27; 127; 427; 721); connection channels (29; 129) between said exit channel (27; 127; 427; 721) and said collection chamber (21; 421; 521; 754).

26) Capsule according to point 25, wherein said exit channel (27; 127; 427; 721) comprises air suction means from the outside (31), so to mix suctioned air and said dissolved drinks.

10

27) Capsule according to point 26, wherein said suction means comprise at least one channel (25; 125) obtained parallel with said exit channel (27; 127; 427; 721) and connected to this with at least one connection port (31).

15

28) Capsule according to point 20, wherein between said second permeable diaphragm (17; 517) and said solution chamber (13; 413; 513; 713) filtering means (37; 437) are placed in, arranged for filtering said dissolved drinks during a transit towards said collection chamber (21; 421; 521; 754).

20

29) Capsule according to point 1, wherein said openable exit means (7; 407; 507; 758) comprise a portion of said bottom (6; 406; 506; 706) breakable according to pre-set braking lines.

25

30) Capsule according to point 1, wherein said perforable closing means comprise a sheet membrane (9; 409; 509; 709) which is perforable and seal-fixable onto a perimeter edge (16; 516) of said inlet opening (4; 404; 504; 704).

30

31) Capsule according to point 4, wherein in said inner cavity (8; 708) are arranged deviator means (410; 453; 533; 534; 710; 753) of said solvent liquid under pressure defining a solution path.

35

32) Capsule according to point 4, wherein said openable exit means comprise: an opening (507) obtained in said bottom (506); a segment of flexible hose (561) fitted on an outer surface of said bottom (506), having a mouth communicating with said opening (507) and an opposite exit communicating with the outside.

40

33) Capsule according to point 32, wherein said segment of flexible hose (561) is flexible between a closing configuration of said opening (507) where it is kept folded and adherent to said outer surface and an opening configuration where it is bent with said opposite extremity turned towards the outside.

45

34) Capsule according to point 33, wherein said segment of flexible hose (561) shapes, at said communicating extremity, a collar adhering to the contour of said opening (507) obtained in said bottom (506).

50

35) Capsule according to point 1, wherein said dispenser means comprise: a dispenser pipe (705) fitted mobile in a soluble drink dispenser machine between an idle position and a dispensing position introduced in said introduction opening: a pusher member (771) integrally mobile with said dispenser pipe (705) and cooperating with said opening means (20; 420; 520; 720) to open said openable exit means

55

(7; 407; 507; 758).

36) Method for the production of instant drinks comprising to prepare a containment capsule (1) loaded with a dose (2; 402; 502) of a powdered soluble drink; to introduce into said capsule (1) a solvent liquid for dissolving said dose, to obtain a dispensing opening (7; 407; 507; 758) with perforator means (20; 420; 520; 720) in an area of said capsule so as to dispense a dissolved drink with said solvent liquid outside of said capsule (1), characterised by the fact that between said to introduce and said dissolving, to compress said dose inside said capsule (1) is contemplated.

37) Method according to point 36, wherein said to compress comprises to compress with flexible diaphragm means (10; 410; 510) arranged transversally inside said capsule (1) and bent towards said dose (2; 402; 502).

38) Method according to point 37, wherein said flexible diaphragm means (10; 410; 510) are flexible by means of said perforator means (20; 420; 520; 720).

39) Method according to point 37, wherein said flexible diaphragm means (10; 410; 510) are flexible by means of pushes generated by pressures of said solvent liquid in said capsule (1).

Claims

1. Capsule (1) for containing doses (502) of soluble drinks comprising a container body (503) that shapes an inner containment cavity (513) for containing at least one dose (502) and which defines: an introductory opening (504) into said inner cavity (513) for a solvent liquid under pressure, dispensable using dispenser means (505), and seal closable using perforable closing means (509) with axial movement of said dispenser means (505); a bottom (506) having openable exit means (507) for the exit of dissolved drinks, **characterised by** the fact that it comprises opening means (520) arranged for opening said openable exit means (507) and cooperating with said dispenser means (505), wherein said opening means (520) can be operated with pressures generated in said inner cavity (513) by dispensing said solvent liquid under pressure dispensed by said dispenser means (505), wherein said openable exit means comprise: an opening (507) obtained in said bottom (506); a segment of flexible hose (561) fitted on an outer surface of said bottom (506) having a mouth communicating with said opening (507); and an opposite exit communicating with the outside.
2. Capsule according to claim 1, wherein said dispenser means comprise a substantially rigid dispenser pipe (505), associated in a mobile way to a dispenser machine between an idle position and a perforation and dispensing position.

3. Capsule according to claim 1, wherein in said inner cavity (513) are arranged separator means (510) defining an inlet chamber (514) for said fluid under pressure and an adjacent solution chamber (513) for said at least one dose with said solvent liquid under pressure.
4. Capsule according to claim 3, wherein said separator means comprise a first diaphragm (510) which can be arranged in said inner cavity (513) substantially parallel with said introduction opening (504).
5. Capsule according to claim 4, wherein said first diaphragm (510) shapes a concave seat (511) that extends towards said bottom (506) and arranged for receiving fitted inside said dispenser pipe (505) in a perforated position of said closing means (509) and in a dispensing position of said solvent liquid under pressure.
6. Capsule according to claim 1 or 5, wherein said first diaphragm (510) is flexible towards said opening means (520) in such a way that in a bent configuration, said concave seat (511) pushes said opening means (520) to open said openable means (507).
7. Capsule according to claim 5 or 6, wherein said bent configuration occurs when said dispenser pipe (505) penetrates said concave seat (511) fitting inside it with a perforation movement of said closing means (509) and a dispensing movement of said solvent liquid under pressure.
8. Capsule according to claim 4, wherein said first diaphragm (510) comprises a plurality of through holes (512) distributed in such a way that said solvent liquid under pressure is distributed in all said at least one dose.
9. Capsule according to any of the preceding claims 4-8, wherein said first diaphragm (510) is circular and said hollow seat (513) is obtained in a substantially centred position.
10. Capsule according to claim 1, wherein said perforable closing means comprise a sheet membrane (509) which is perforable and seal-fixable onto a perimeter edge (516) of said inlet opening (504).
11. Capsule according to claim 1, wherein in said inner cavity (513) are arranged deviator means (533; 534) of said solvent liquid under pressure defining a solution path.
12. Capsule according to claim 1 or 11, wherein said segment of flexible hose (561) is flexible between a closing configuration of said opening (507) where it is kept folded and adherent to said outer surface and

an opening configuration where it is bent with said opposite extremity turned towards the outside.

- 13. Capsule according to claim 12, wherein said segment of flexible hose (561) shapes, at said communicating extremity, a collar adhering to the contour of said opening (507) obtained in said bottom (506).

5

10

15

20

25

30

35

40

45

50

55

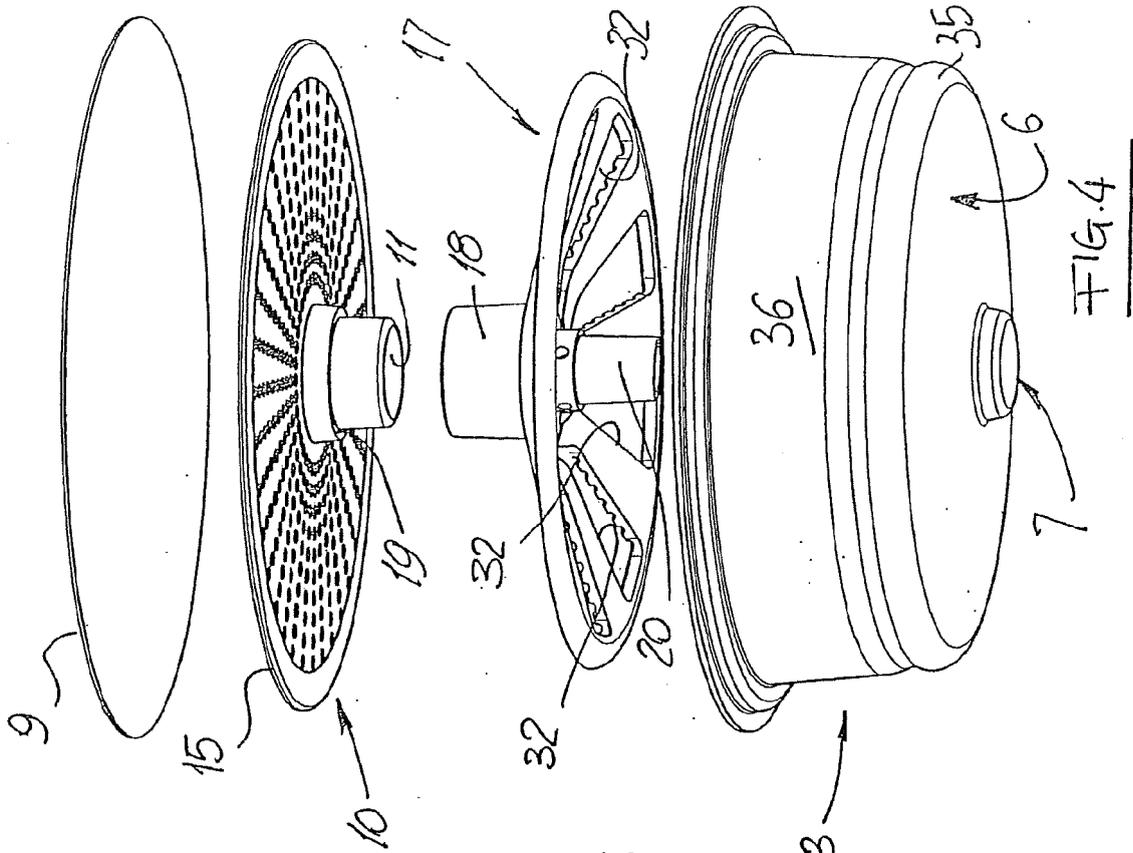

FIG. 4

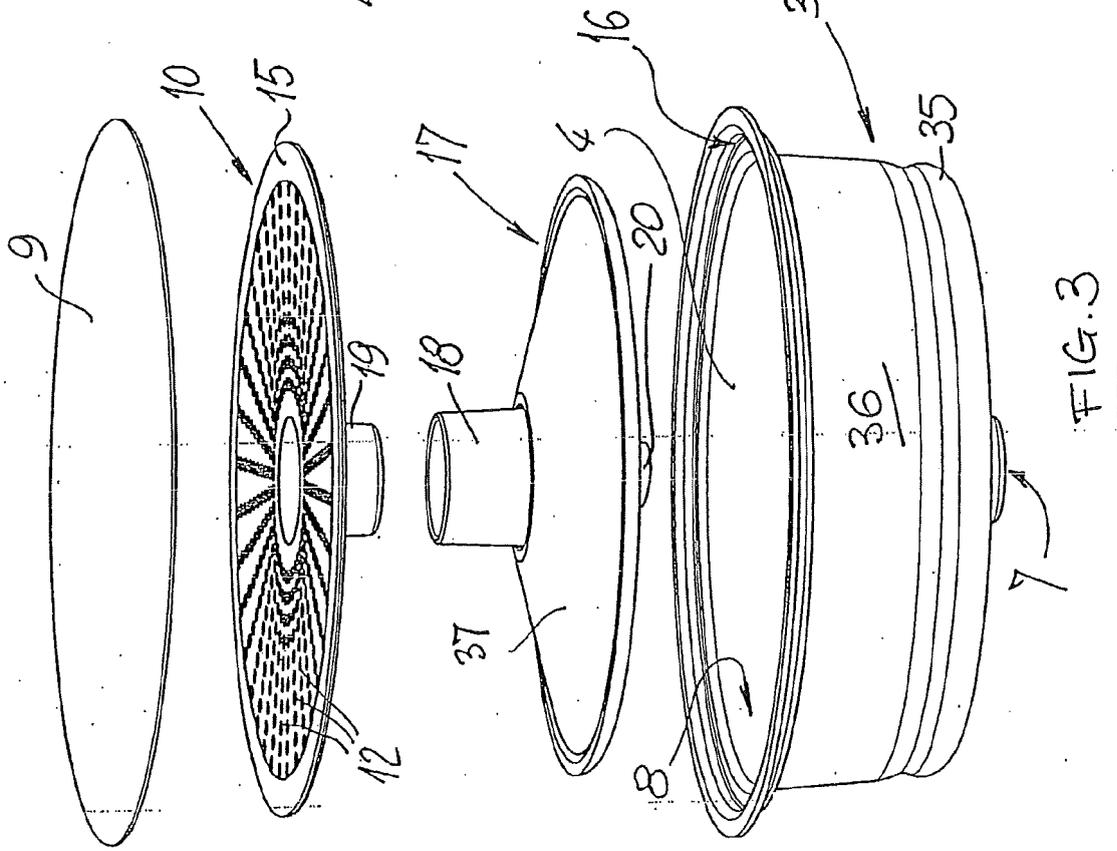
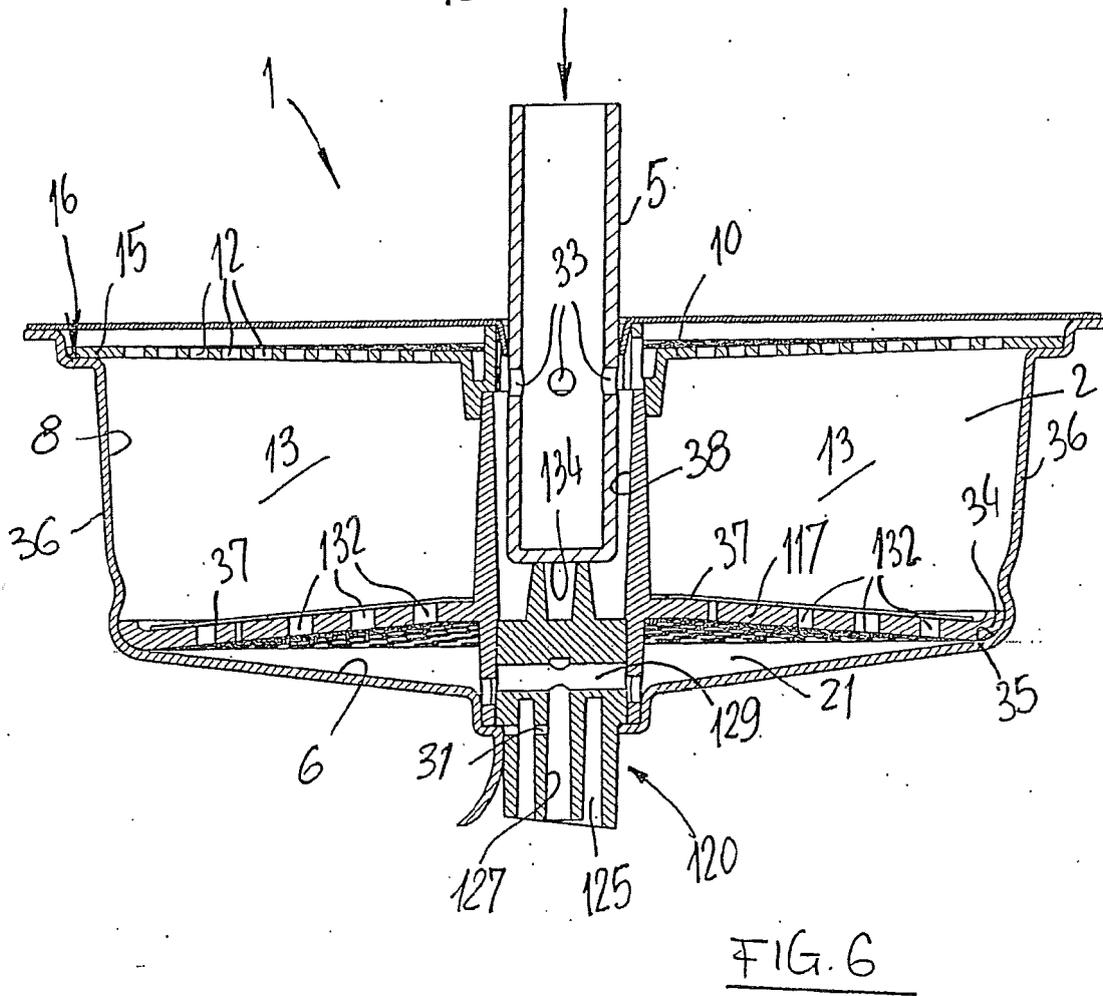
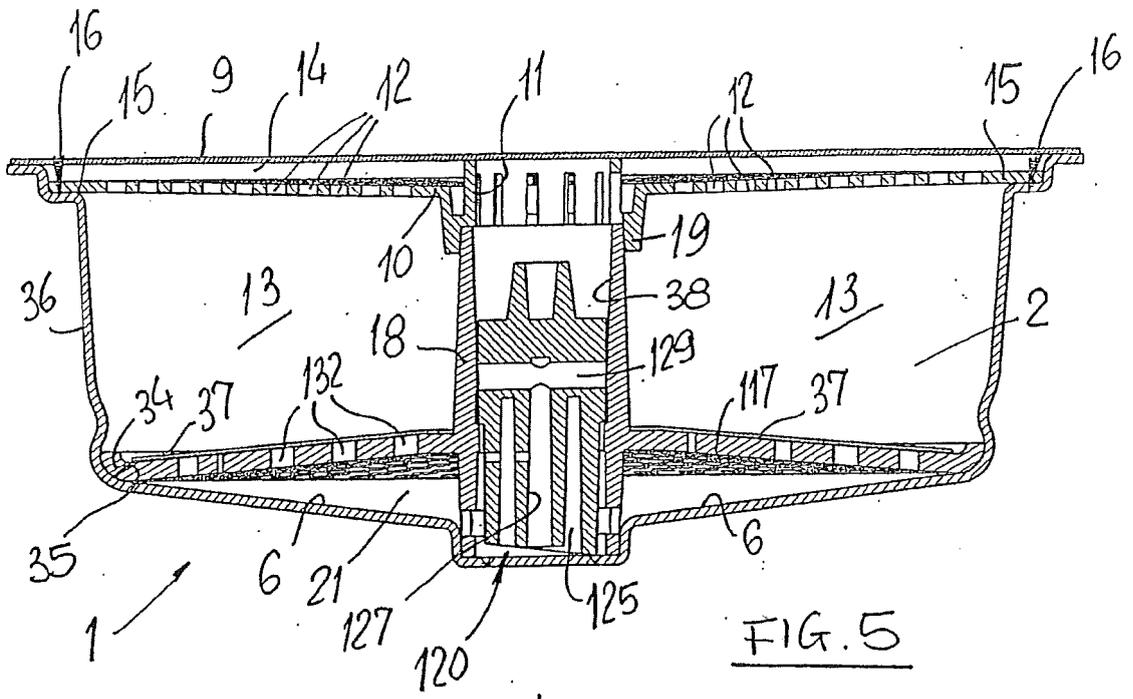

FIG. 3



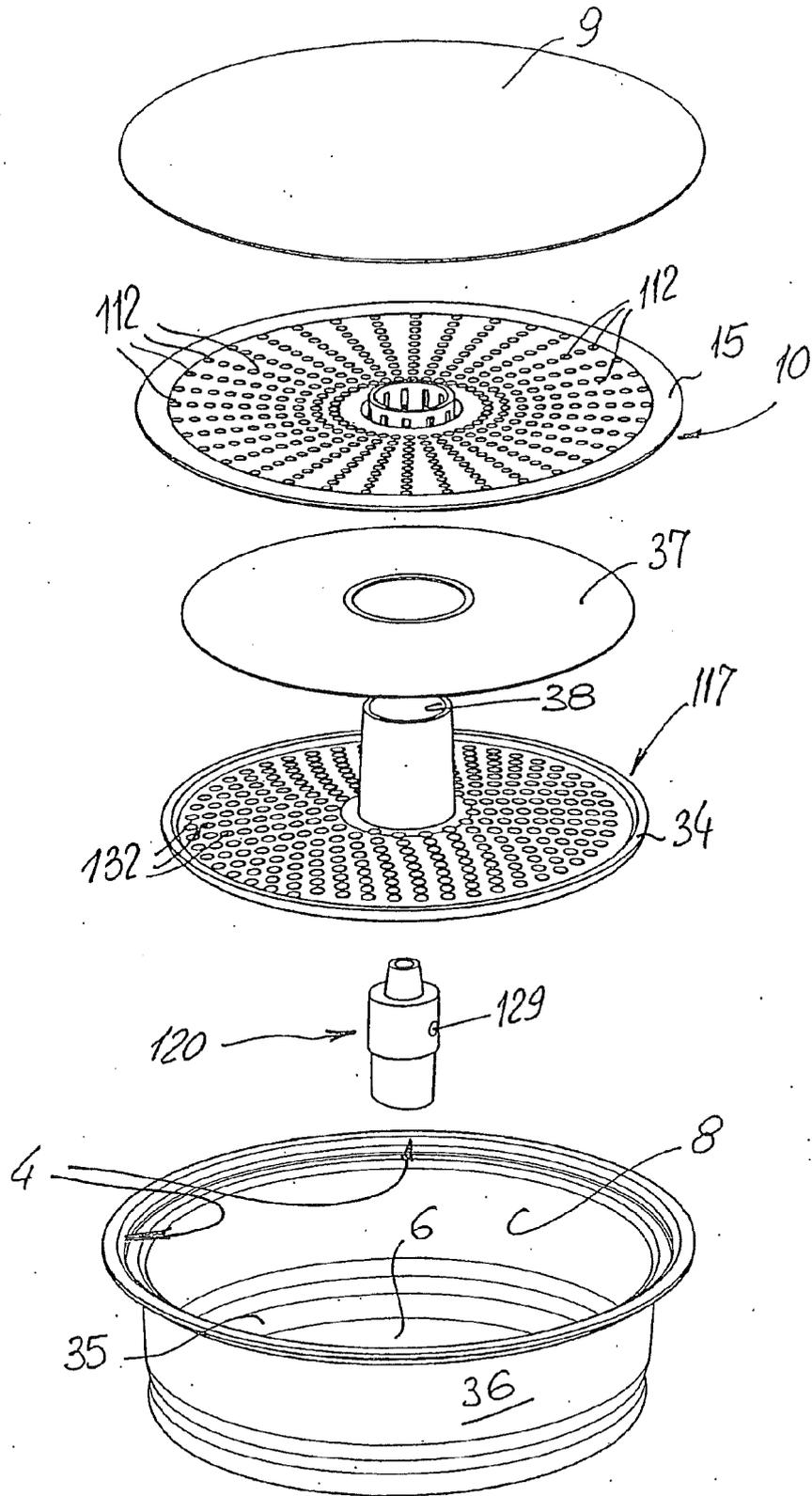
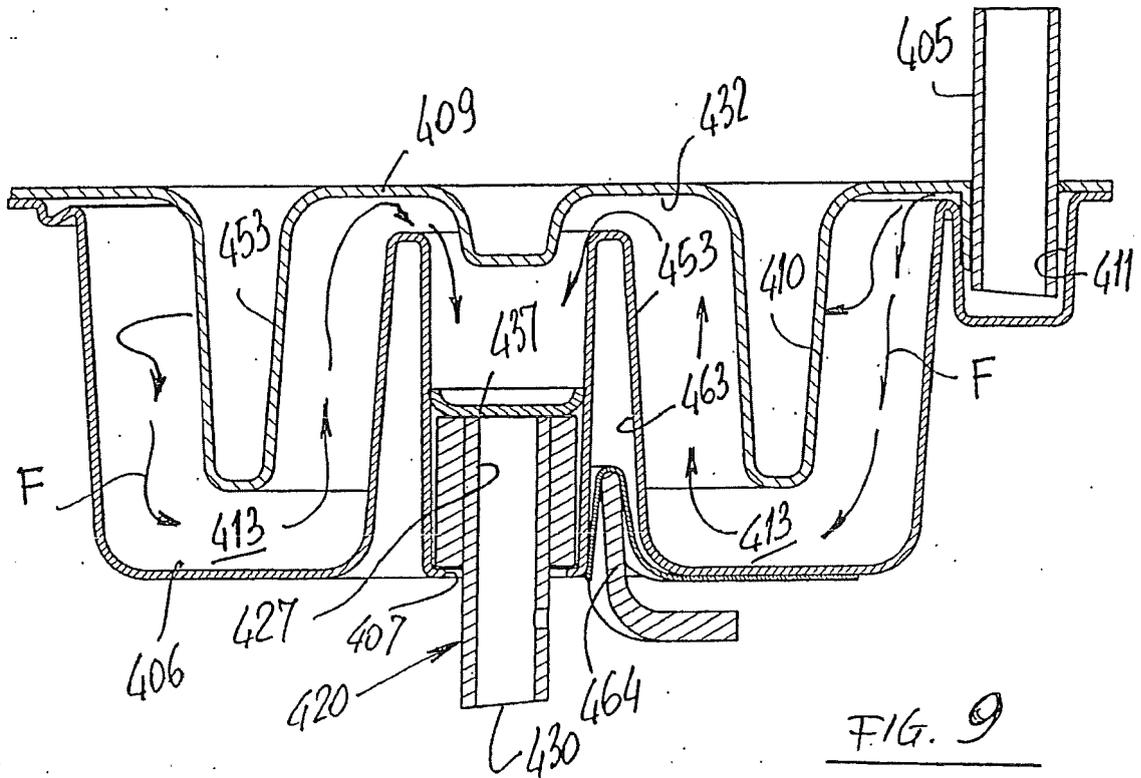
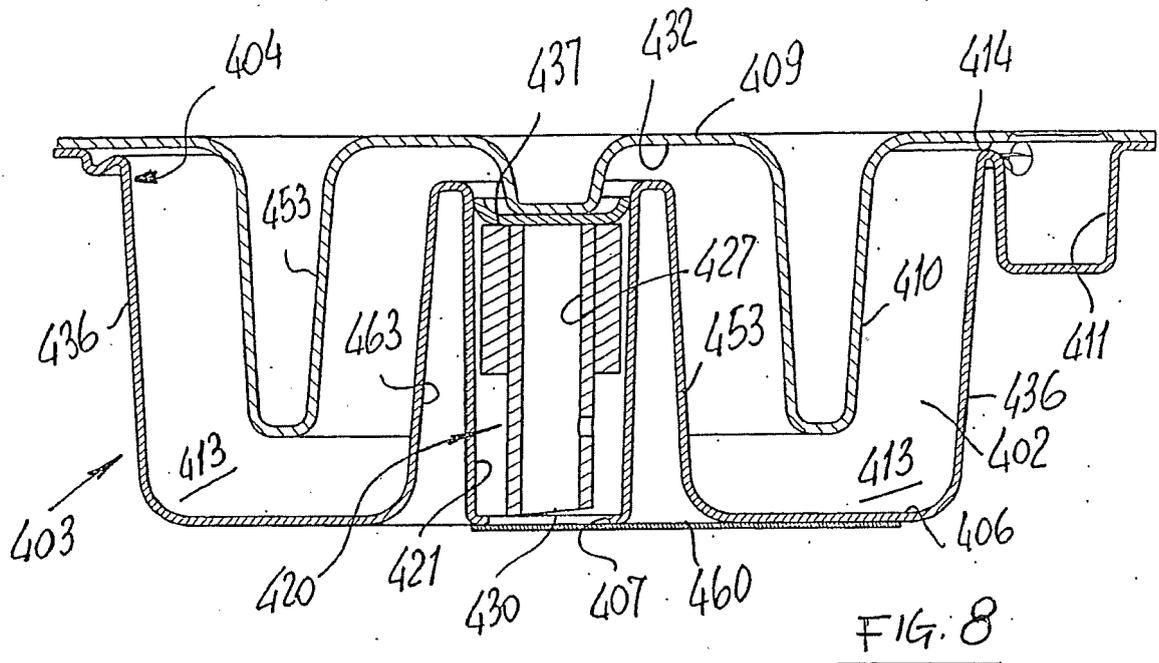
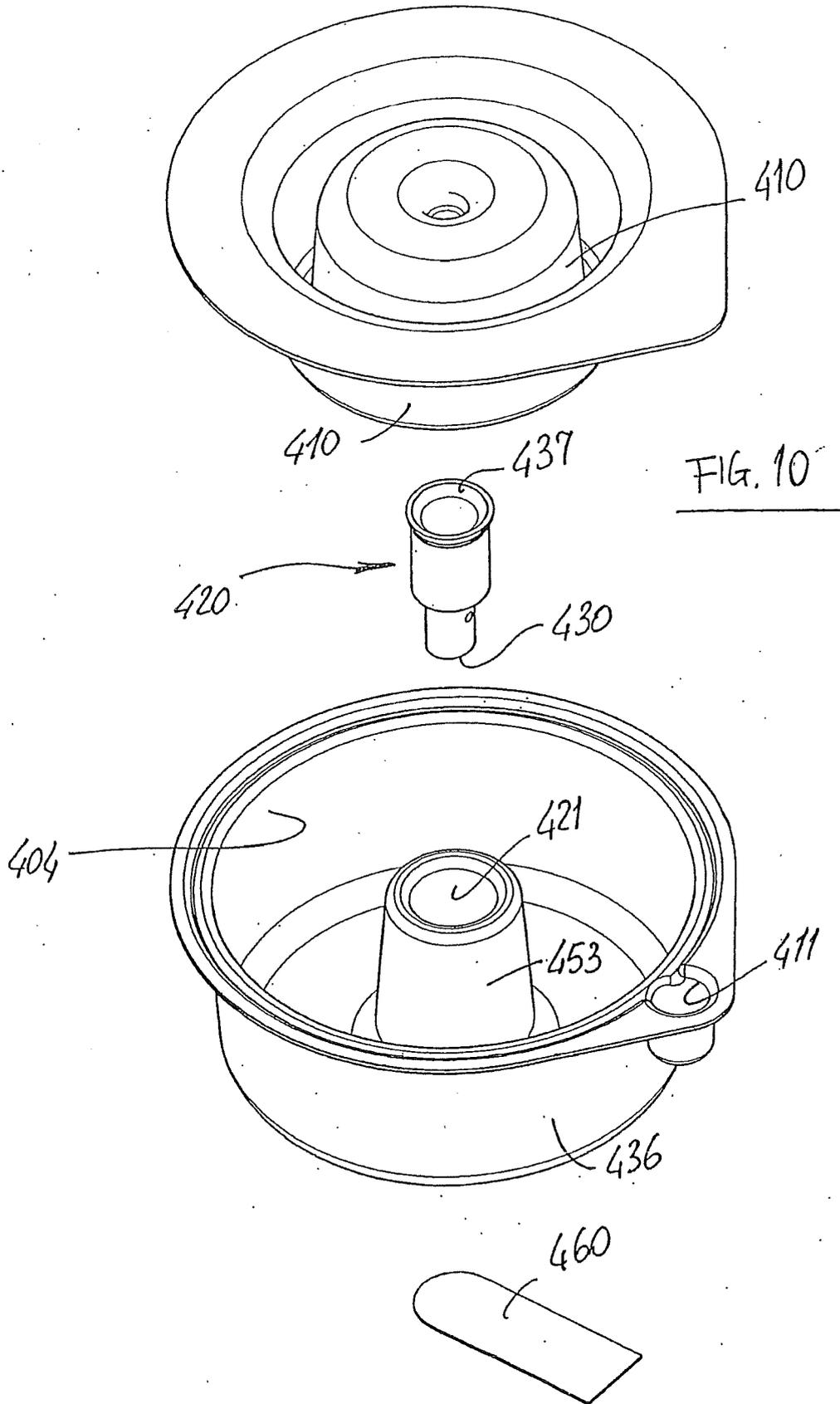

FIG. 7





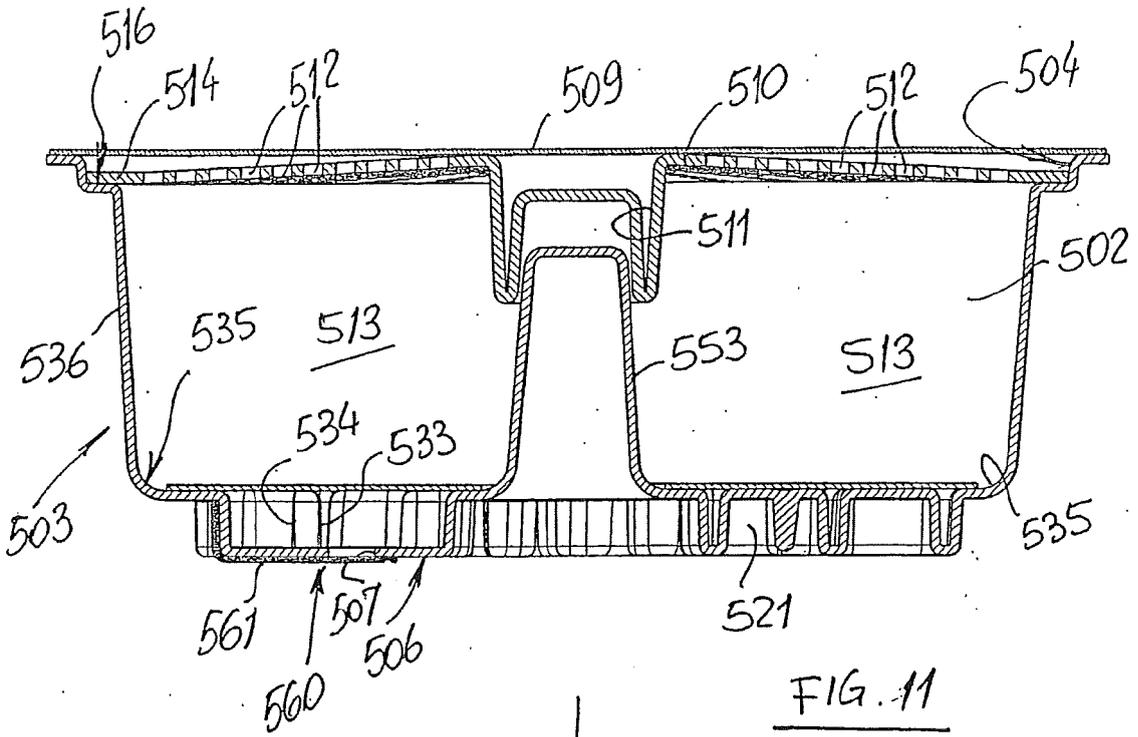

FIG. 11

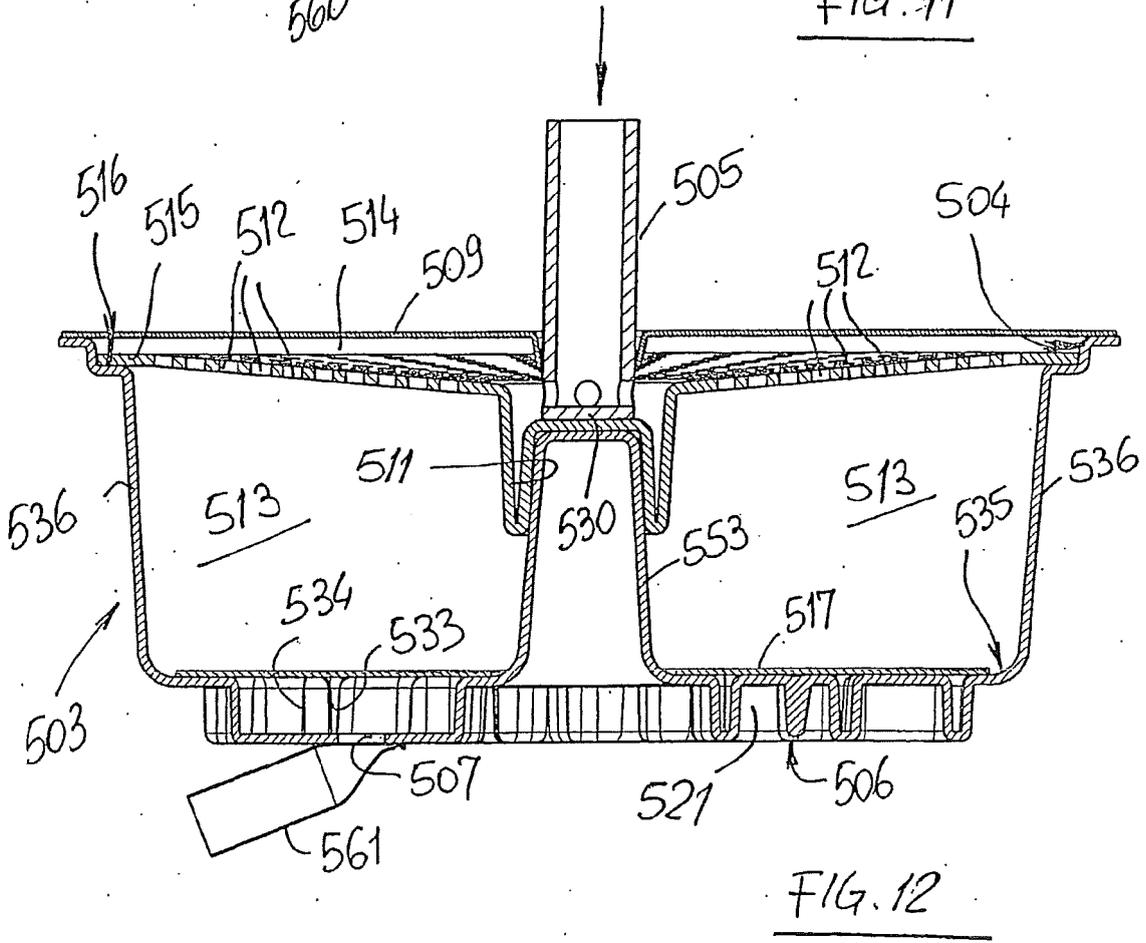

FIG. 12

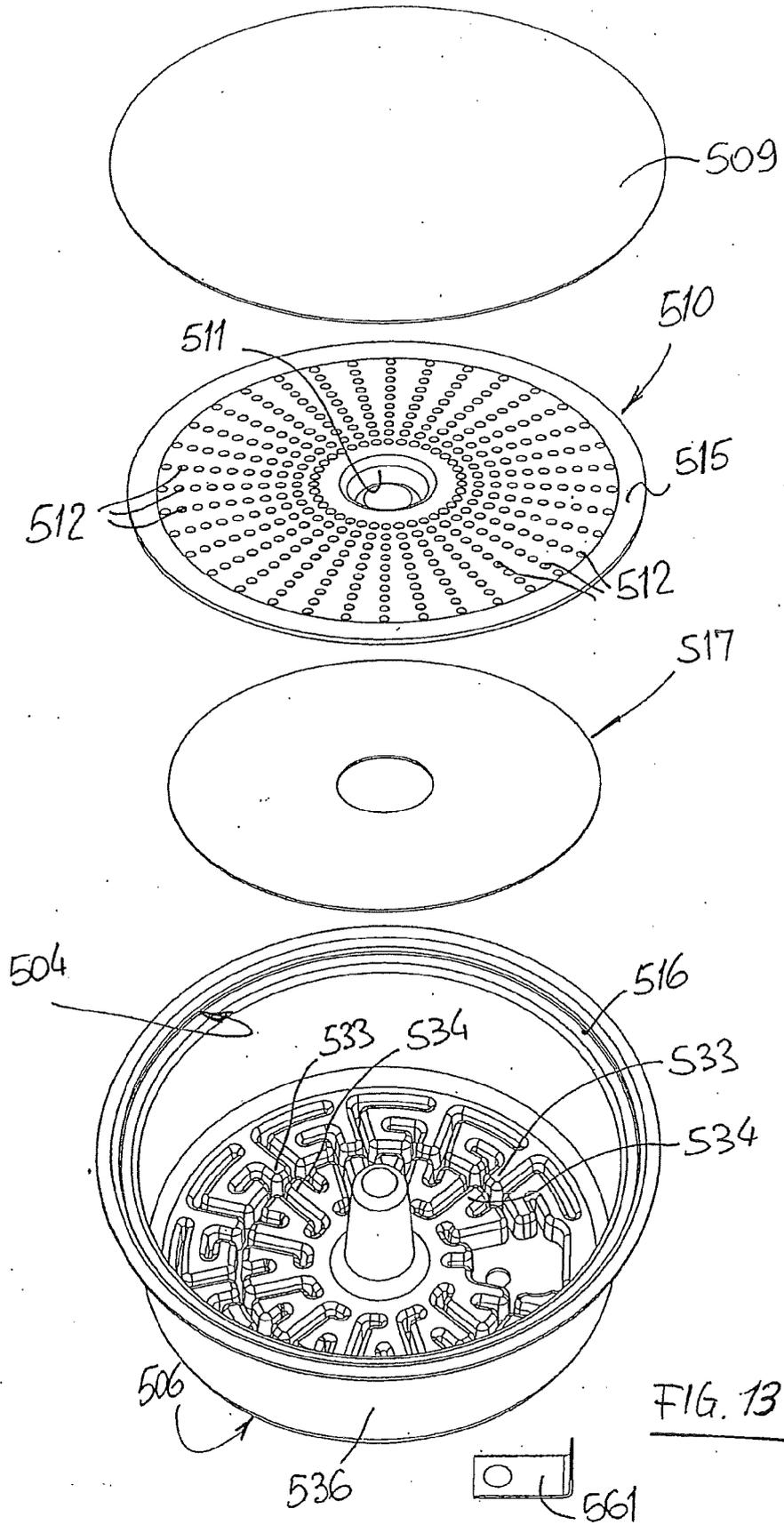
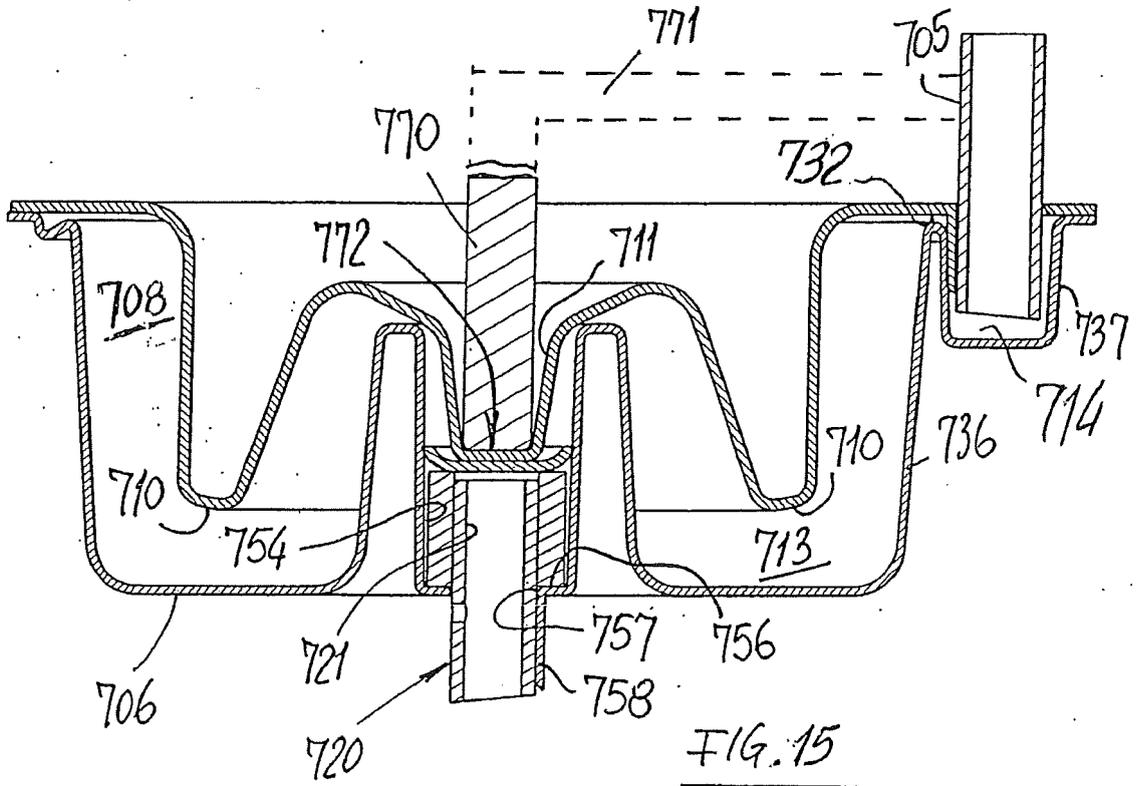
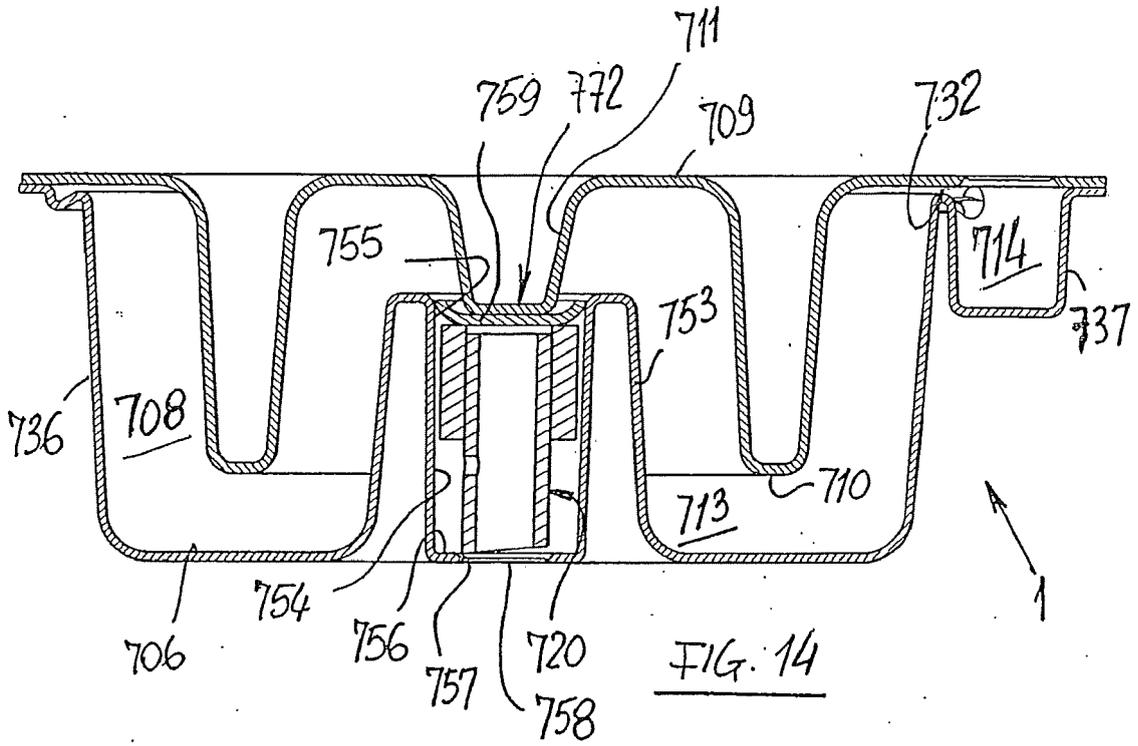

FIG. 13



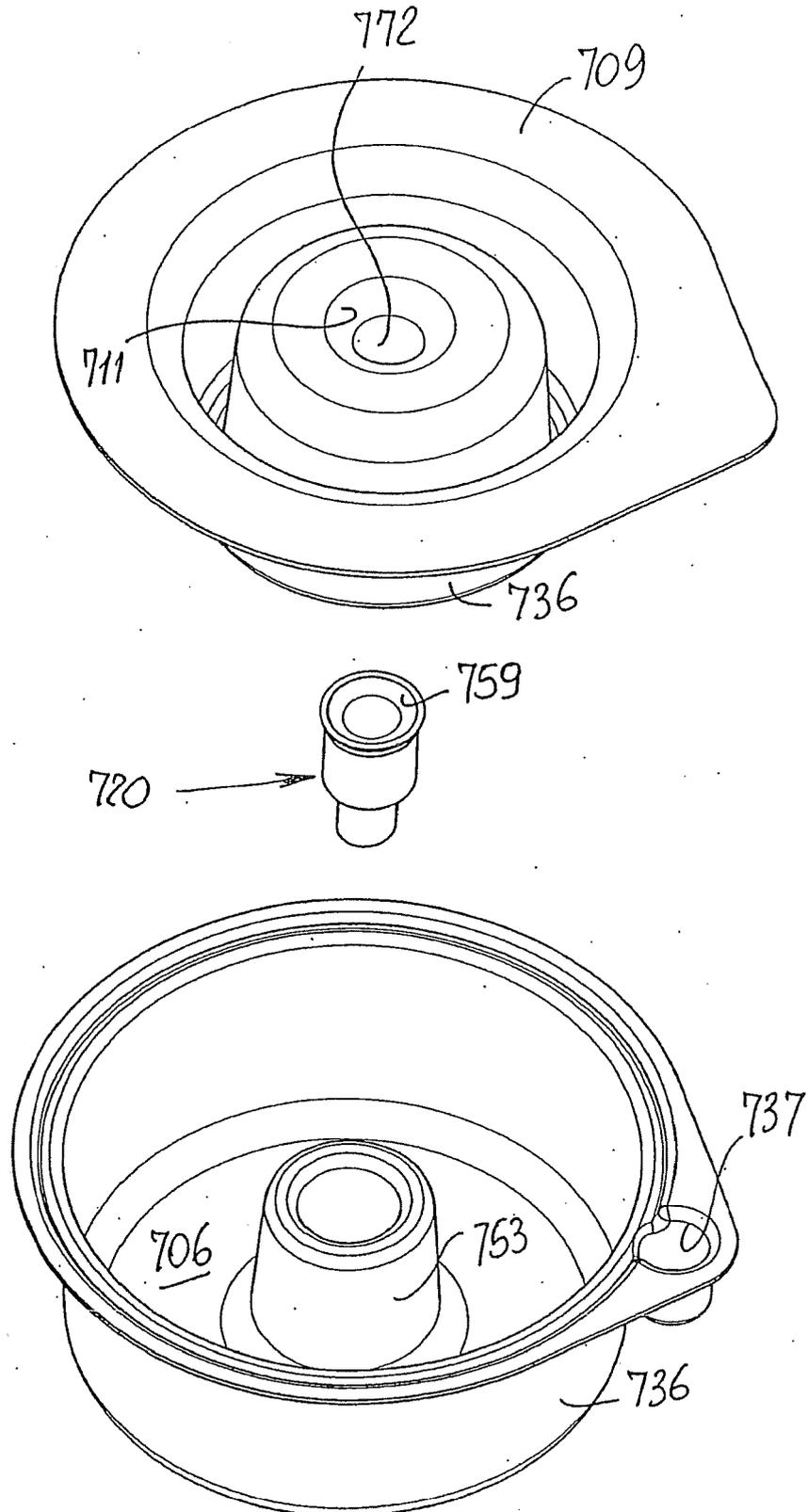

FIG. 16



EUROPEAN SEARCH REPORT

 Application Number
 EP 11 15 7215

DOCUMENTS CONSIDERED TO BE RELEVANT			
Category	Citation of document with indication, where appropriate, of relevant passages	Relevant to claim	CLASSIFICATION OF THE APPLICATION (IPC)
A,D	WO 2005/092160 A (ILLYCAFFE SPA [IT]; SUGGI LIVERANI FURIO [IT]; MASTROPASQUA LUCA [IT];) 6 October 2005 (2005-10-06) * abstract; figures 1,2 * * page 29, last paragraph - page 31, line 23; figures 12-15,24,25 * -----	1-13	INV. B65D85/804 TECHNICAL FIELDS SEARCHED (IPC) B65D
A	EP 1 440 913 A (KRAFT FOODS R & D INC [DE]) 28 July 2004 (2004-07-28) * abstract; figures 1,5,7,11,35,36,40,42 * * paragraph [0026] - paragraph [0053] * -----	1-13	
A,D	US 2006/236871 A1 (TERNITE RUDIGER [DE] ET AL) 26 October 2006 (2006-10-26) * paragraph [0032] - paragraph [0039]; figures 1-3 * * paragraph [0043] * -----	1-13	
A,D	WO 2005/018395 A (NESTEC SA [CH]; MANDRALIS ZENON IOANNIS [CH]; KOCH PETER [CH]; CAMPICH) 3 March 2005 (2005-03-03) * abstract; figures 2,3 * -----	1-13	
A,D	WO 2004/087529 A (HAUSBRANDT TRIESTE 1892 SPA [IT]; ZANETTI MARTINO [IT]) 14 October 2004 (2004-10-14) * abstract; figure 4 * * page 2, line 11 - page 3, paragraph 1 * -----	1-13	
A,D	WO 2005/080223 A (TUTTOESPRESSO S P A [IT]; DOGLIONI MAJER LUCA [IT]) 1 September 2005 (2005-09-01) * abstract; figures 1,5 * * page 7, line 7 - page 8, line 13 * -----	1-13	
A,D	WO 92/07775 A (COFFEA SA [CH]) 14 May 1992 (1992-05-14) * abstract; figures 2,3 * -----	1-13	
-/--			
The present search report has been drawn up for all claims			
2	Place of search Munich	Date of completion of the search 29 April 2011	Examiner Segerer, Heiko
CATEGORY OF CITED DOCUMENTS X : particularly relevant if taken alone Y : particularly relevant if combined with another document of the same category A : technological background O : non-written disclosure P : intermediate document		T : theory or principle underlying the invention E : earlier patent document, but published on, or after the filing date D : document cited in the application L : document cited for other reasons & : member of the same patent family, corresponding document	

EPO FORM 1503 03.02 (P04C01)



EUROPEAN SEARCH REPORT

Application Number
EP 11 15 7215

DOCUMENTS CONSIDERED TO BE RELEVANT			
Category	Citation of document with indication, where appropriate, of relevant passages	Relevant to claim	CLASSIFICATION OF THE APPLICATION (IPC)
A,D	WO 2006/045536 A (NESTEC SA [CH]; YOAKIM ALFRED [CH]; GAVILLET GILLES [CH]; DENISART JEA) 4 May 2006 (2006-05-04) * abstract; figure 6 * -----	1-13	
			TECHNICAL FIELDS SEARCHED (IPC)
The present search report has been drawn up for all claims			
Place of search Munich		Date of completion of the search 29 April 2011	Examiner Segerer, Heiko
CATEGORY OF CITED DOCUMENTS X : particularly relevant if taken alone Y : particularly relevant if combined with another document of the same category A : technological background O : non-written disclosure P : intermediate document		T : theory or principle underlying the invention E : earlier patent document, but published on, or after the filing date D : document cited in the application L : document cited for other reasons & : member of the same patent family, corresponding document	

2
EPO FORM 1503 03.02 (P04C01)

ANNEX TO THE EUROPEAN SEARCH REPORT
ON EUROPEAN PATENT APPLICATION NO.

EP 11 15 7215

This annex lists the patent family members relating to the patent documents cited in the above-mentioned European search report.
The members are as contained in the European Patent Office EDP file on
The European Patent Office is in no way liable for these particulars which are merely given for the purpose of information.

29-04-2011

Patent document cited in search report		Publication date	Patent family member(s)	Publication date
WO 2005092160	A	06-10-2005	AU 2005226884	A1 06-10-2005
			BR PI0509166	A 11-09-2007
			CA 2560841	A1 06-10-2005
			JP 2007530108	T 01-11-2007
			US 2007186784	A1 16-08-2007
			US 2010043644	A1 25-02-2010
			US 2010043645	A1 25-02-2010
			US 2010043646	A1 25-02-2010
EP 1440913	A	28-07-2004	AR 042912	A1 06-07-2005
			AT 328811	T 15-06-2006
			AU 2004205386	A1 05-08-2004
			BR PI0406877	A 03-01-2006
			CA 2514072	A1 05-08-2004
			CN 1761604	A 19-04-2006
			DE 602004001053	T2 12-04-2007
			DK 1440913	T3 25-09-2006
			ES 2267000	T3 01-03-2007
			GB 2397500	A 28-07-2004
			WO 2004065257	A1 05-08-2004
			HK 1065756	A1 12-01-2007
			JP 4227169	B2 18-02-2009
			JP 2006516419	T 06-07-2006
			JP 2009006179	A 15-01-2009
			KR 20050107747	A 15-11-2005
			MX PA05007863	A 18-10-2005
			PE 08712004	A1 25-11-2004
PL 204651	B1 29-01-2010			
RU 2337046	C2 27-10-2008			
TW I278298	B 11-04-2007			
US 2006236871	A1	26-10-2006	DE 102005016297	A1 12-10-2006
			EP 1710173	A1 11-10-2006
WO 2005018395	A	03-03-2005	AR 045078	A1 12-10-2005
			AT 373438	T 15-10-2007
			AU 2004266432	A1 03-03-2005
			BR PI0412242	A 12-09-2006
			CA 2529364	A1 03-03-2005
			CL 18622004	A1 03-06-2005
			CN 1826071	A 30-08-2006
			DE 60316426	T2 19-06-2008
			DK 1500358	T3 29-10-2007
			EP 1500358	A1 26-01-2005
			ES 2292885	T3 16-03-2008
			HK 1093303	A1 03-09-2010

EPO FORM P0459

For more details about this annex : see Official Journal of the European Patent Office, No. 12/82

ANNEX TO THE EUROPEAN SEARCH REPORT
ON EUROPEAN PATENT APPLICATION NO.

EP 11 15 7215

This annex lists the patent family members relating to the patent documents cited in the above-mentioned European search report.
The members are as contained in the European Patent Office EDP file on
The European Patent Office is in no way liable for these particulars which are merely given for the purpose of information.

29-04-2011

Patent document cited in search report	Publication date	Patent family member(s)	Publication date
WO 2005018395 A		JP 4604031 B2	22-12-2010
		JP 2006528497 T	21-12-2006
		MX PA06000870 A	04-05-2006
		PT 1500358 E	19-10-2007
		US 2006219098 A1	05-10-2006
-----	-----	-----	-----
WO 2004087529 A	14-10-2004	AT 350300 T	15-01-2007
		AU 2003293658 A1	25-10-2004
		BR 0318217 A	21-03-2006
		CA 2521063 A1	14-10-2004
		CN 1759049 A	12-04-2006
		DE 60311014 T2	16-08-2007
		DK 1608569 T3	30-04-2007
		EG 24373 A	16-03-2009
		EP 1608569 A1	28-12-2005
		ES 2279212 T3	16-08-2007
		HK 1086803 A1	03-08-2007
		HR 20050869 A2	31-12-2005
		IL 170957 A	18-11-2009
		IS 8020 A	12-09-2005
		JP 4339800 B2	07-10-2009
		JP 2006513790 T	27-04-2006
		KR 20050121684 A	27-12-2005
		MX PA05010348 A	27-01-2006
		NZ 542470 A	29-02-2008
		PL 203078 B1	31-08-2009
		PT 1608569 E	30-04-2007
RS P20050721 A	15-11-2007		
RU 2311109 C2	27-11-2007		
UA 78925 C2	25-04-2007		
US 2006019000 A1	26-01-2006		
ZA 200507320 A	27-12-2006		
-----	-----	-----	-----
WO 2005080223 A	01-09-2005	AT 470633 T	15-06-2010
		AU 2005214158 A1	01-09-2005
		EP 1708934 A1	11-10-2006
		ES 2347158 T3	26-10-2010
		IL 176532 A	30-12-2010
		PE 07342005 A1	04-11-2005
-----	-----	-----	-----
WO 9207775 A	14-05-1992	AT 400291 B	27-11-1995
		AU 650064 B2	09-06-1994
		BE 1006165 A5	31-05-1994
		CA 2072367 A1	01-05-1992
		CH 682909 A5	15-12-1993

EPO FORM P0459

For more details about this annex : see Official Journal of the European Patent Office, No. 12/82

ANNEX TO THE EUROPEAN SEARCH REPORT
ON EUROPEAN PATENT APPLICATION NO.

EP 11 15 7215

This annex lists the patent family members relating to the patent documents cited in the above-mentioned European search report.
The members are as contained in the European Patent Office EDP file on
The European Patent Office is in no way liable for these particulars which are merely given for the purpose of information.

29-04-2011

Patent document cited in search report	Publication date	Patent family member(s)	Publication date
		CH 688686 A5	15-01-1998
WO 9207775 A		DE 4192762 C2	19-09-2002
		DE 4192762 T	28-01-1993
		DK 85792 A	30-06-1992
		EP 1783066 A2	09-05-2007
		EP 0507905 A1	14-10-1992
		ES 2085823 A1	01-06-1996
		FR 2668451 A1	30-04-1992
		GB 2255494 A	11-11-1992
		IT 1250066 B	30-03-1995
		JP 8032249 B	29-03-1996
		JP 5502817 T	20-05-1993
		LU 88131 A1	15-02-1993
		NL 9120010 A	01-10-1992
		PT 99373 A	31-01-1994
		SE 513548 C2	02-10-2000
		US 5472719 A	05-12-1995
-----	-----	-----	-----
WO 2006045536 A	04-05-2006	AR 055279 A1	15-08-2007
		AT 347837 T	15-01-2007
		AT 419769 T	15-01-2009
		AT 399495 T	15-07-2008
		AT 369062 T	15-08-2007
		AU 2005298933 A1	04-05-2006
		AU 2005298954 A1	04-05-2006
		AU 2010201295 A1	22-04-2010
		BR PI0517030 A	30-09-2008
		BR PI0517296 A	07-10-2008
		CA 2581293 A1	04-05-2006
		CA 2584884 A1	04-05-2006
		CA 2728461 A1	04-05-2006
		CN 101043835 A	26-09-2007
		CN 101048094 A	03-10-2007
		CN 101803870 A	18-08-2010
		CN 102001496 A	06-04-2011
		CR 11312 A	21-04-2010
		DE 602004003713 T2	18-10-2007
		DE 602004008113 T2	15-05-2008
		DE 602004010435 T2	16-10-2008
		DK 1654966 T3	19-02-2007
		DK 1816935 T3	11-05-2009
		DK 1816936 T3	08-09-2008
		DK 1700548 T3	17-09-2007
		DK 1702543 T3	07-01-2008
		EC SP077350 A	26-04-2007

EPO FORM P0459

For more details about this annex : see Official Journal of the European Patent Office, No. 12/82

ANNEX TO THE EUROPEAN SEARCH REPORT
ON EUROPEAN PATENT APPLICATION NO.

EP 11 15 7215

This annex lists the patent family members relating to the patent documents cited in the above-mentioned European search report. The members are as contained in the European Patent Office EDP file on
The European Patent Office is in no way liable for these particulars which are merely given for the purpose of information.

29-04-2011

Patent document cited in search report	Publication date	Patent family member(s)	Publication date
WO 2006045536 A		EP 1654966 A1	10-05-2006
		EP 1816935 A2	15-08-2007
		EP 1816936 A1	15-08-2007
		EP 1700548 A1	13-09-2006
		EP 1702543 A2	20-09-2006
		EP 2098144 A1	09-09-2009
		EP 2210540 A1	28-07-2010
		WO 2006045515 A2	04-05-2006
		ES 2277184 T3	01-07-2007
		ES 2317314 T3	16-04-2009
		ES 2309804 T3	16-12-2008
		ES 2292154 T3	01-03-2008
		ES 2297791 T3	01-05-2008
		HK 1091703 A1	30-05-2008
		HK 1112166 A1	20-02-2009
		HK 1112569 A1	27-11-2009
		JP 2008517639 T	29-05-2008
		JP 2008517838 T	29-05-2008
		JP 2010155118 A	15-07-2010
		KR 20070085287 A	27-08-2007
	KR 20100049650 A	12-05-2010	
	NZ 553635 A	29-10-2010	

REFERENCES CITED IN THE DESCRIPTION

This list of references cited by the applicant is for the reader's convenience only. It does not form part of the European patent document. Even though great care has been taken in compiling the references, errors or omissions cannot be excluded and the EPO disclaims all liability in this regard.

Patent documents cited in the description

- WO 2005092160 A **[0006]**
- WO 2005018395 A **[0009]**
- WO 2004087529 A1 **[0016]**
- WO 2005080223 A **[0024]**
- US 20060236871 A **[0029]**
- WO 9207775 A **[0037]**
- WO 2006045536 A **[0048]**