



US 20050036718A1

(19) **United States**

(12) **Patent Application Publication**

Wu et al.

(10) **Pub. No.: US 2005/0036718 A1**

(43) **Pub. Date: Feb. 17, 2005**

(54) **SEALABLE BAG HAVING AN INTEGRATED VALVE STRUCTURE FOR USE IN VACUUM PACKAGING**

(75) Inventors: **Hongyu Wu**, San Jose, CA (US);
Charles Wade Albritton, Hercules, CA (US); **David Brakes**, Hong Kong (CN)

Correspondence Address:
FLIESLER MEYER, LLP
FOUR EMBARCADERO CENTER
SUITE 400
SAN FRANCISCO, CA 94111 (US)

(73) Assignee: **Tilia International, Inc.**, San Francisco, CA

(21) Appl. No.: **10/794,354**

(22) Filed: **Mar. 4, 2004**

Related U.S. Application Data

(60) Provisional application No. 60/451,955, filed on Mar. 5, 2003. Provisional application No. 60/452,168, filed on Mar. 5, 2003. Provisional application No. 60/452,138, filed on Mar. 5, 2003. Provisional application No. 60/452,172, filed on Mar. 5, 2003. Provisional application No. 60/452,171, filed on Mar. 5, 2003. Provisional application No. 60/451,954, filed on Mar.

5, 2003. Provisional application No. 60/451,948, filed on Mar. 5, 2003. Provisional application No. 60/452,142, filed on Mar. 5, 2003. Provisional application No. 60/452,021, filed on Mar. 5, 2003. Provisional application No. 60/451,956, filed on Mar. 5, 2003. Provisional application No. 60/452,157, filed on Mar. 5, 2003. Provisional application No. 60/452,139, filed on Mar. 5, 2003.

Publication Classification

(51) **Int. Cl.⁷** **B65D 30/22**
(52) **U.S. Cl.** **383/103; 383/109; 383/105; 383/116**

(57) **ABSTRACT**

A bag for use in vacuum packaging comprises a first panel and a second panel overlapping each other. A valve structure is formed on the first panel for evacuating air and/or other gases from inside the bag when a suction source is placed over the valve, and for sealing the bag when the suction source is removed. The first panel and second panel can each include integrated features for forming a zipper or clasp for sealing the bag. This description is not intended to be a complete description of, or limit the scope of, the invention. Other features, aspects, and objects of the invention can be obtained from a review of the specification, the figures, and the claims.

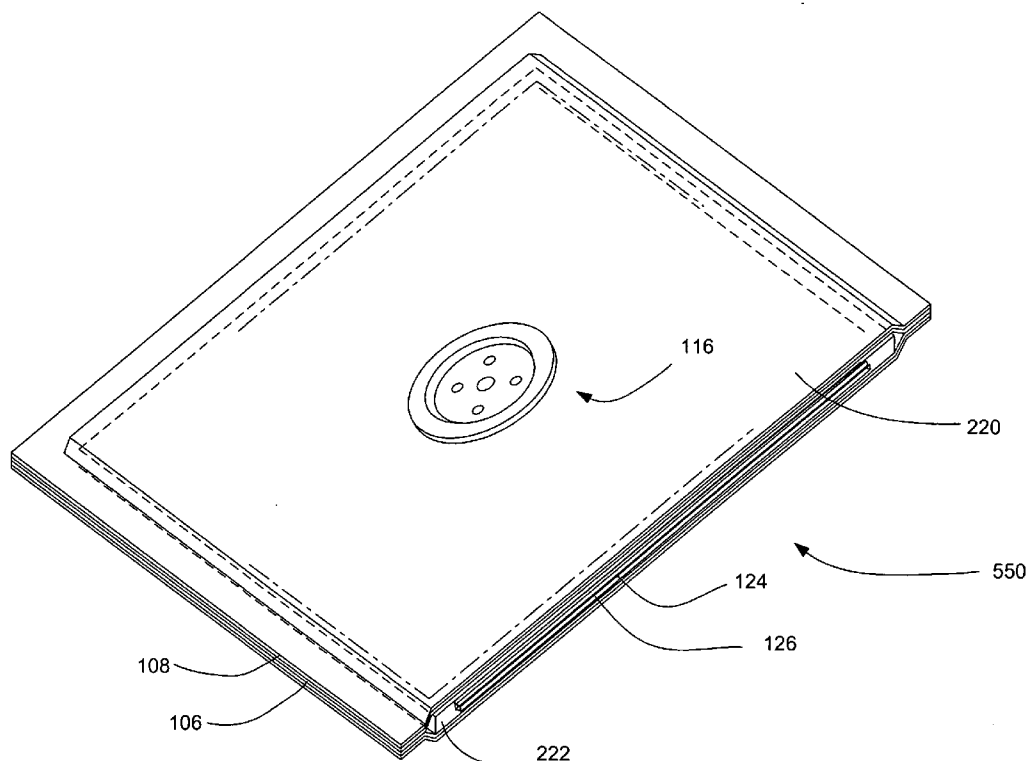

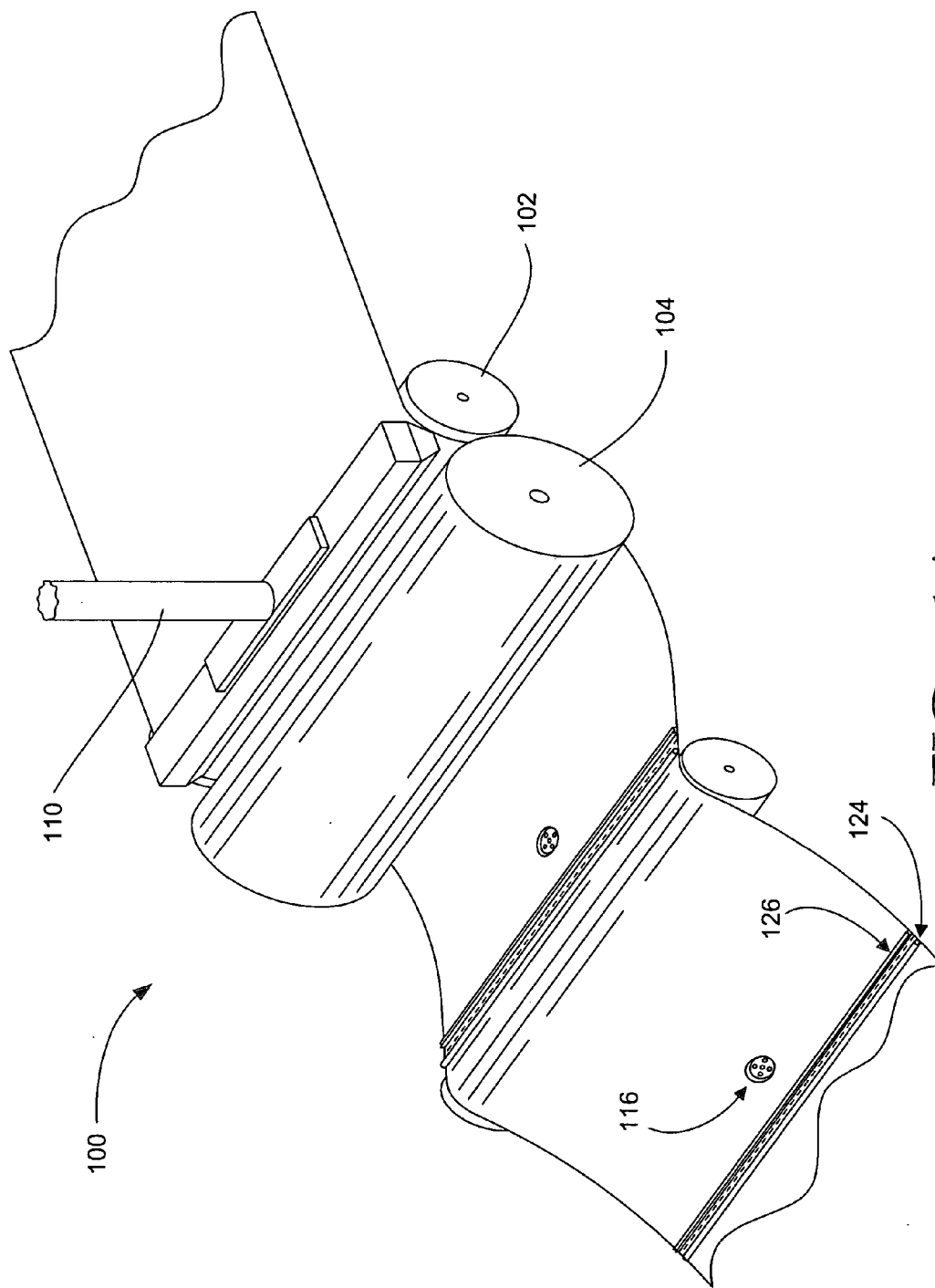

FIG. - 1A

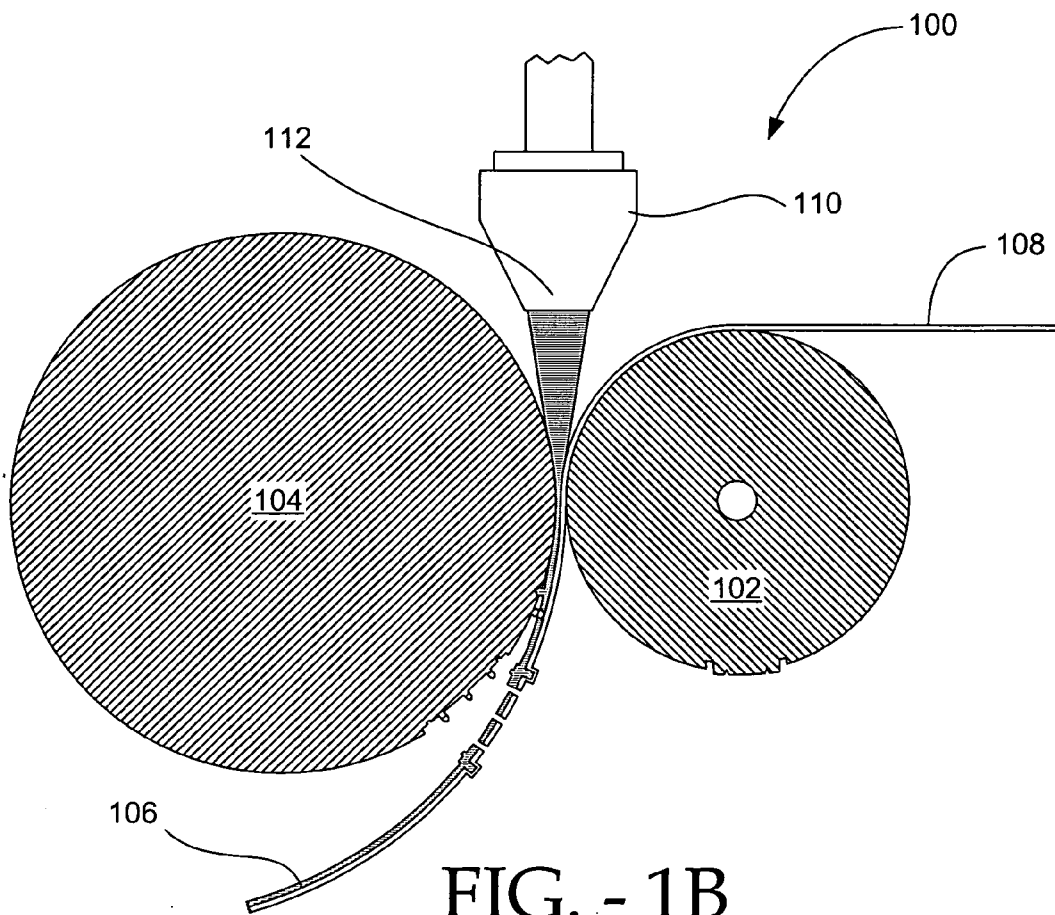

FIG. - 1B

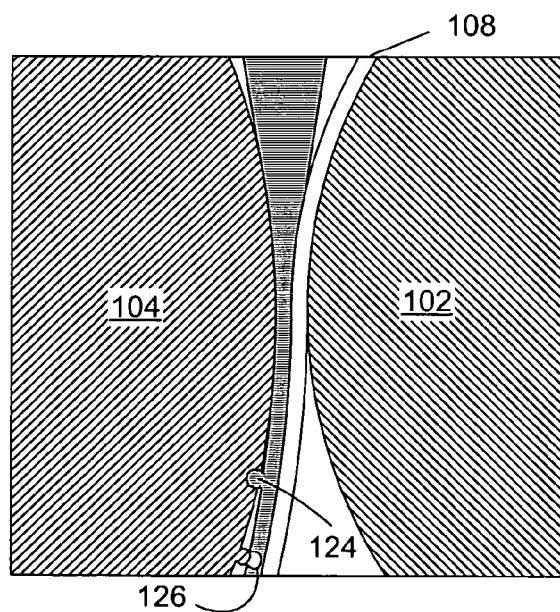

FIG. - 1C

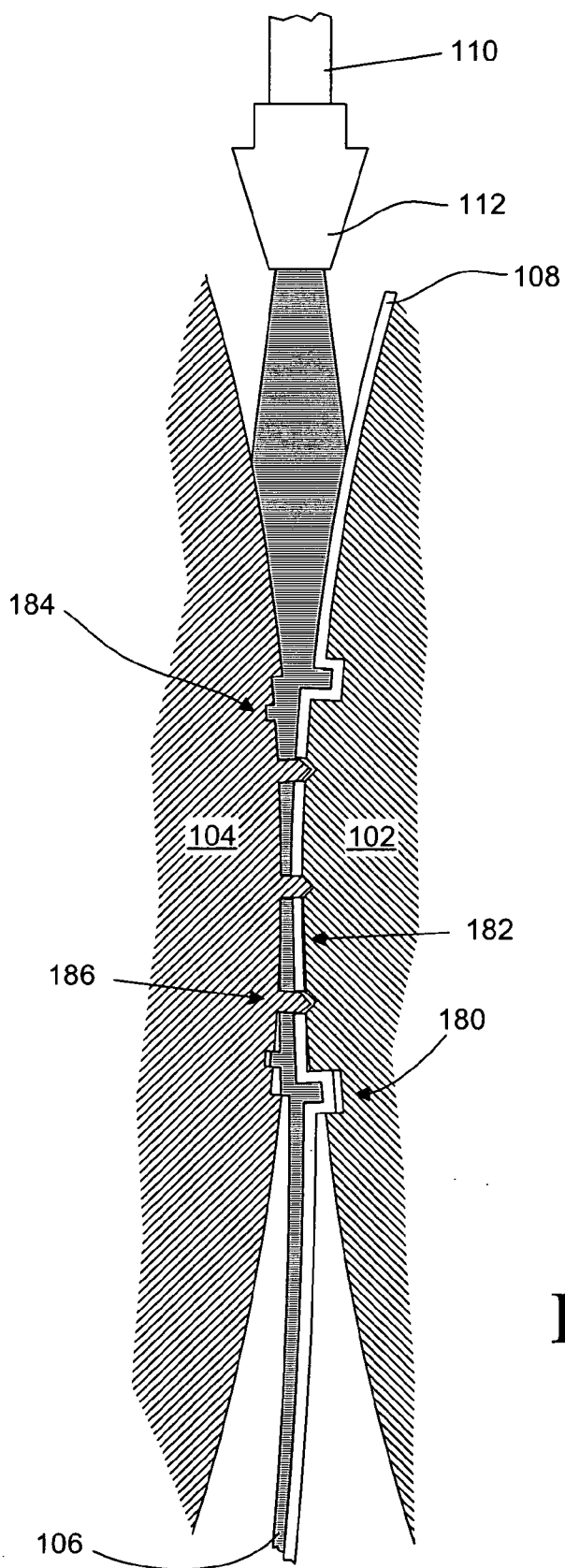

FIG. - 1D

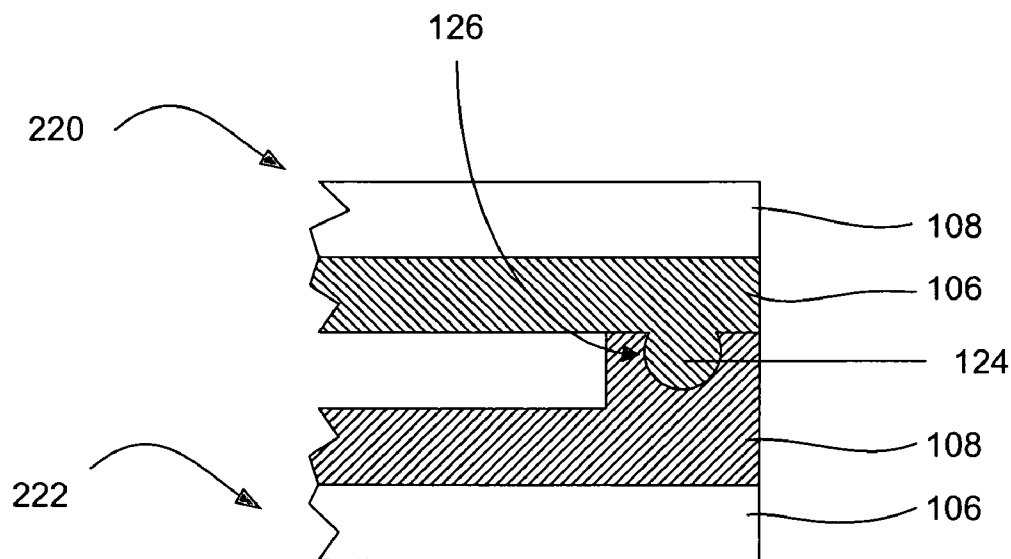

FIG. - 2A

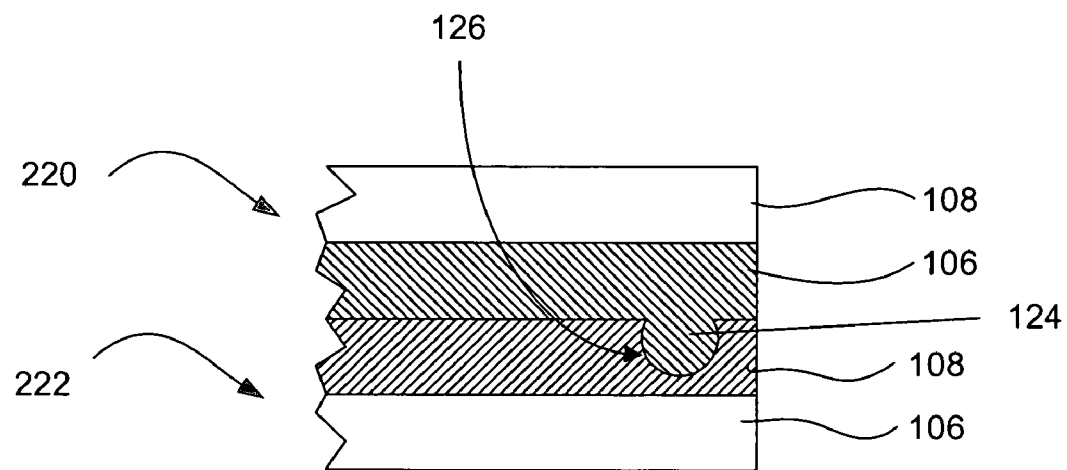

FIG. - 2B

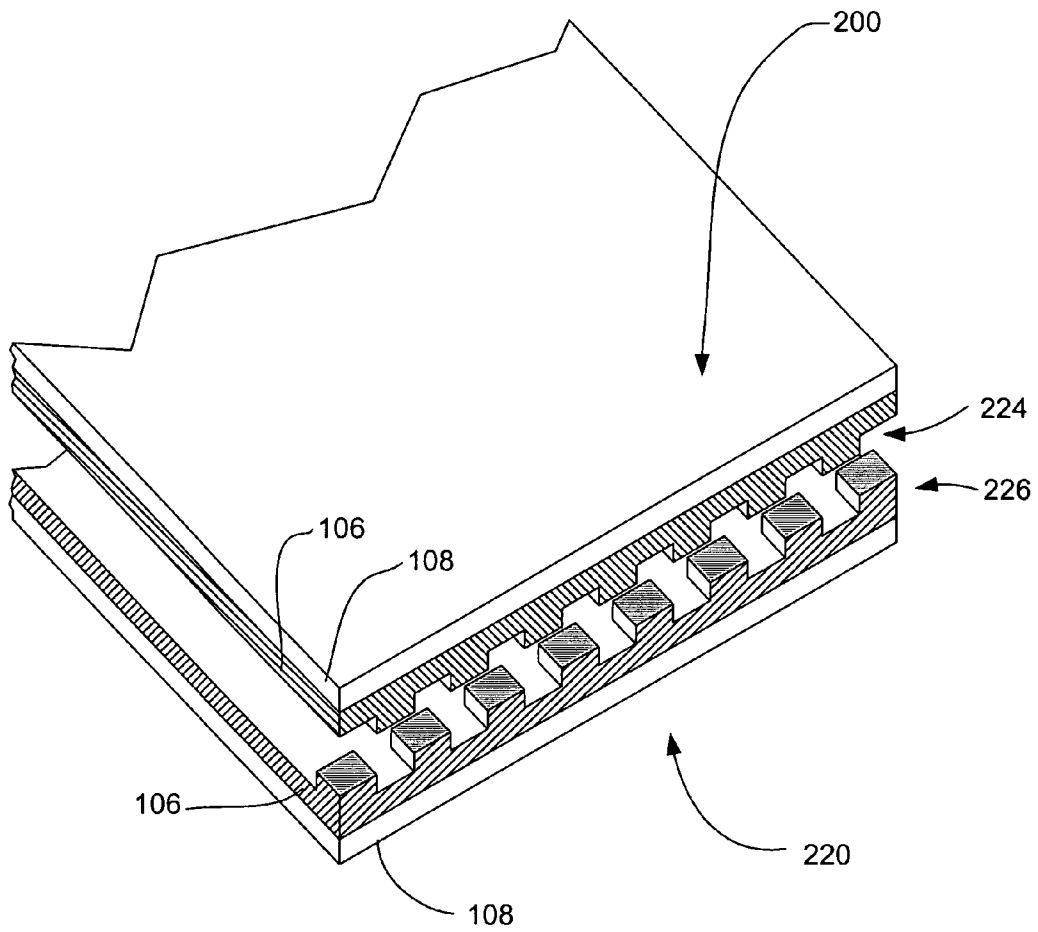

FIG. - 2C

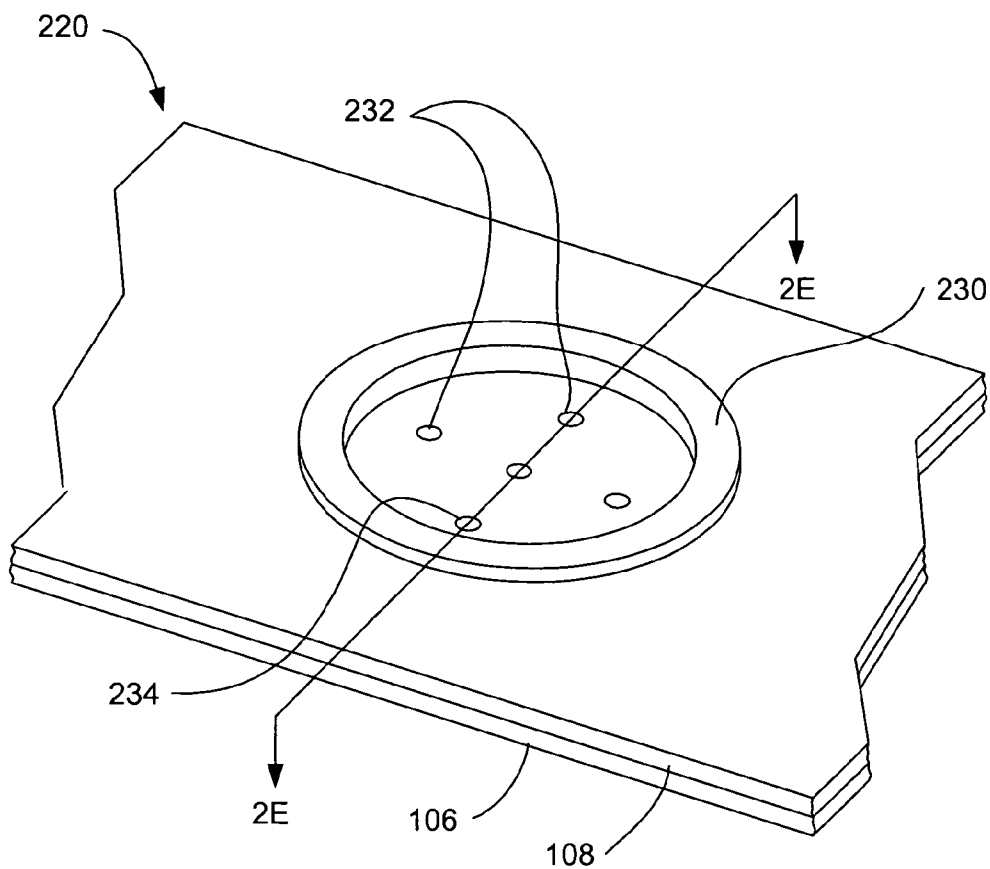

FIG. - 2D

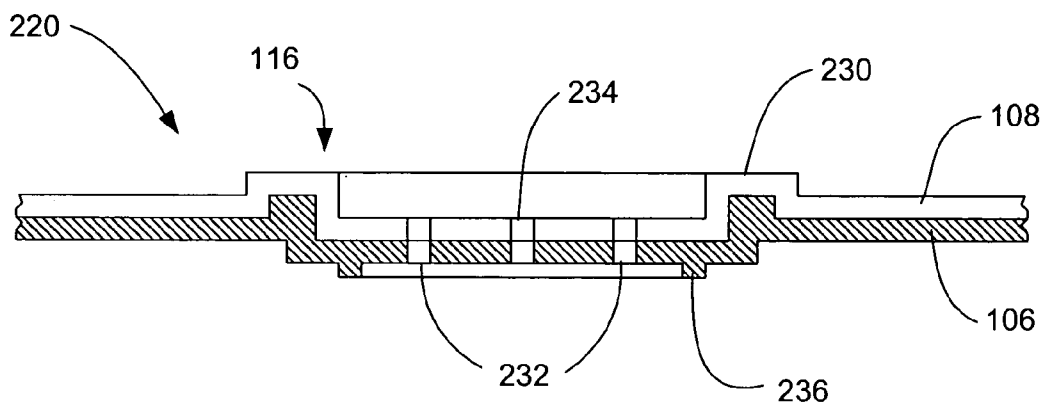

FIG. - 2E

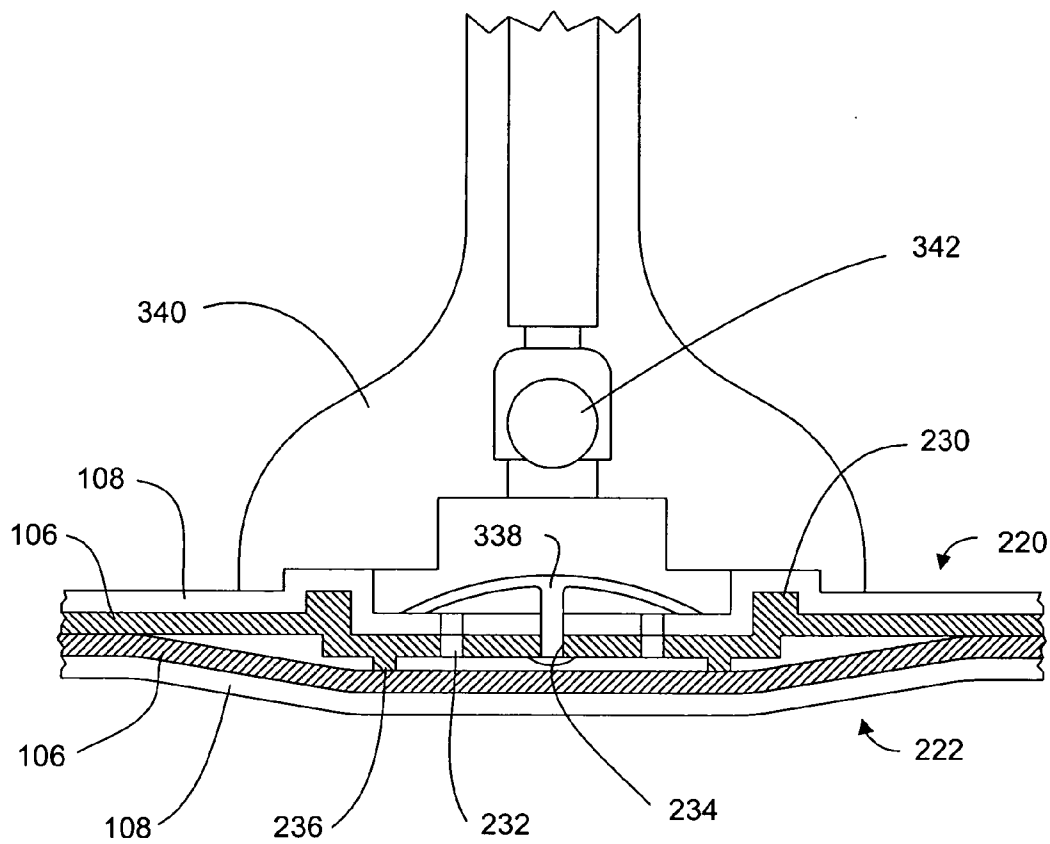

FIG. - 3

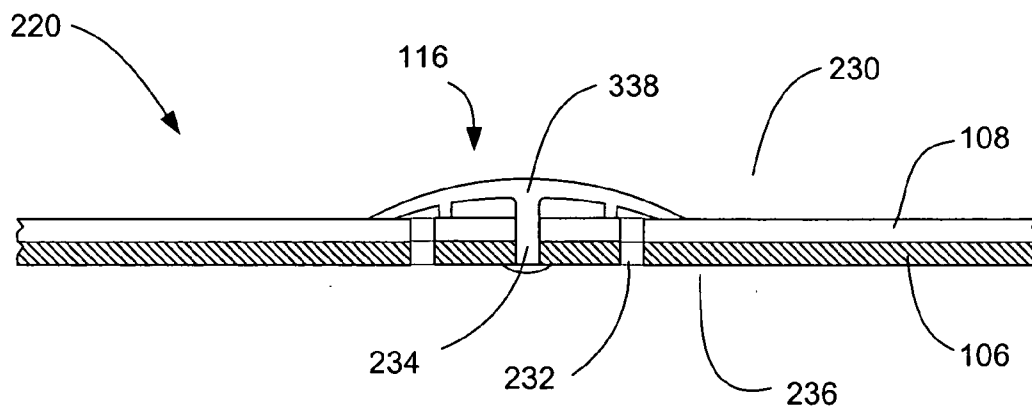

FIG. - 4A

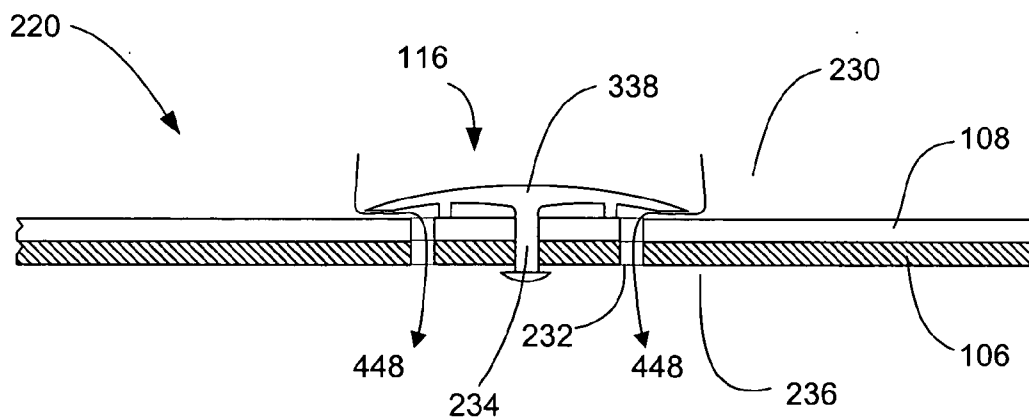

FIG. - 4B

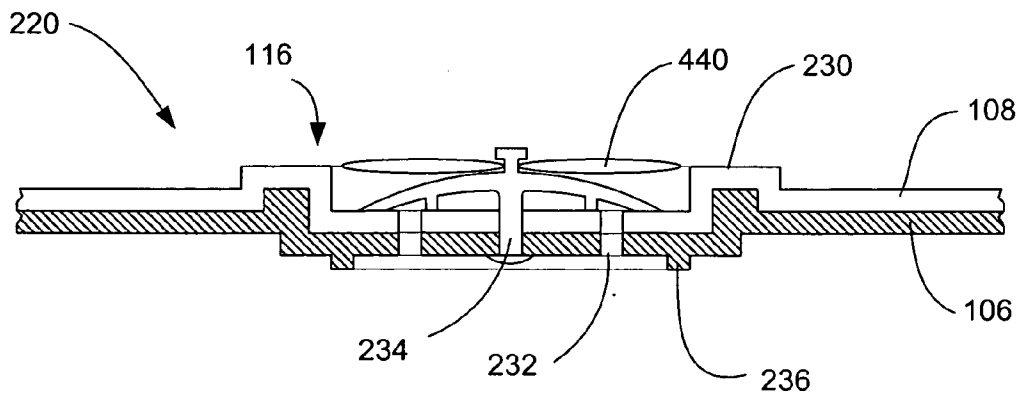

FIG. - 4C

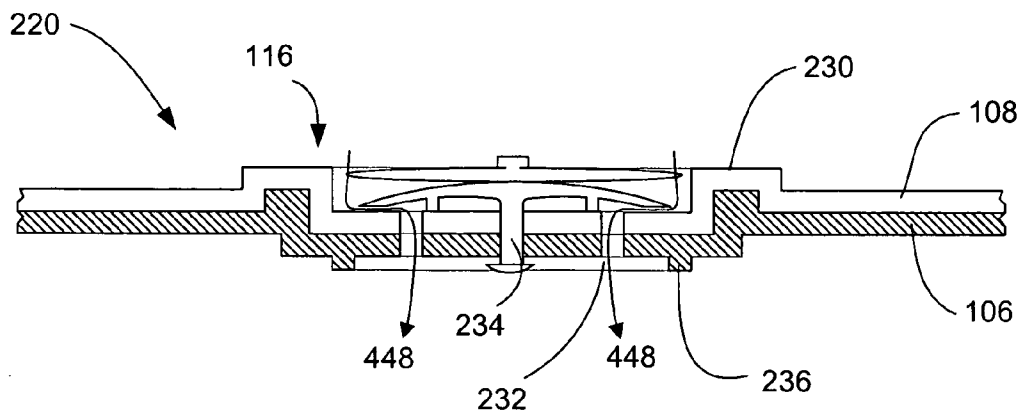

FIG. - 4D

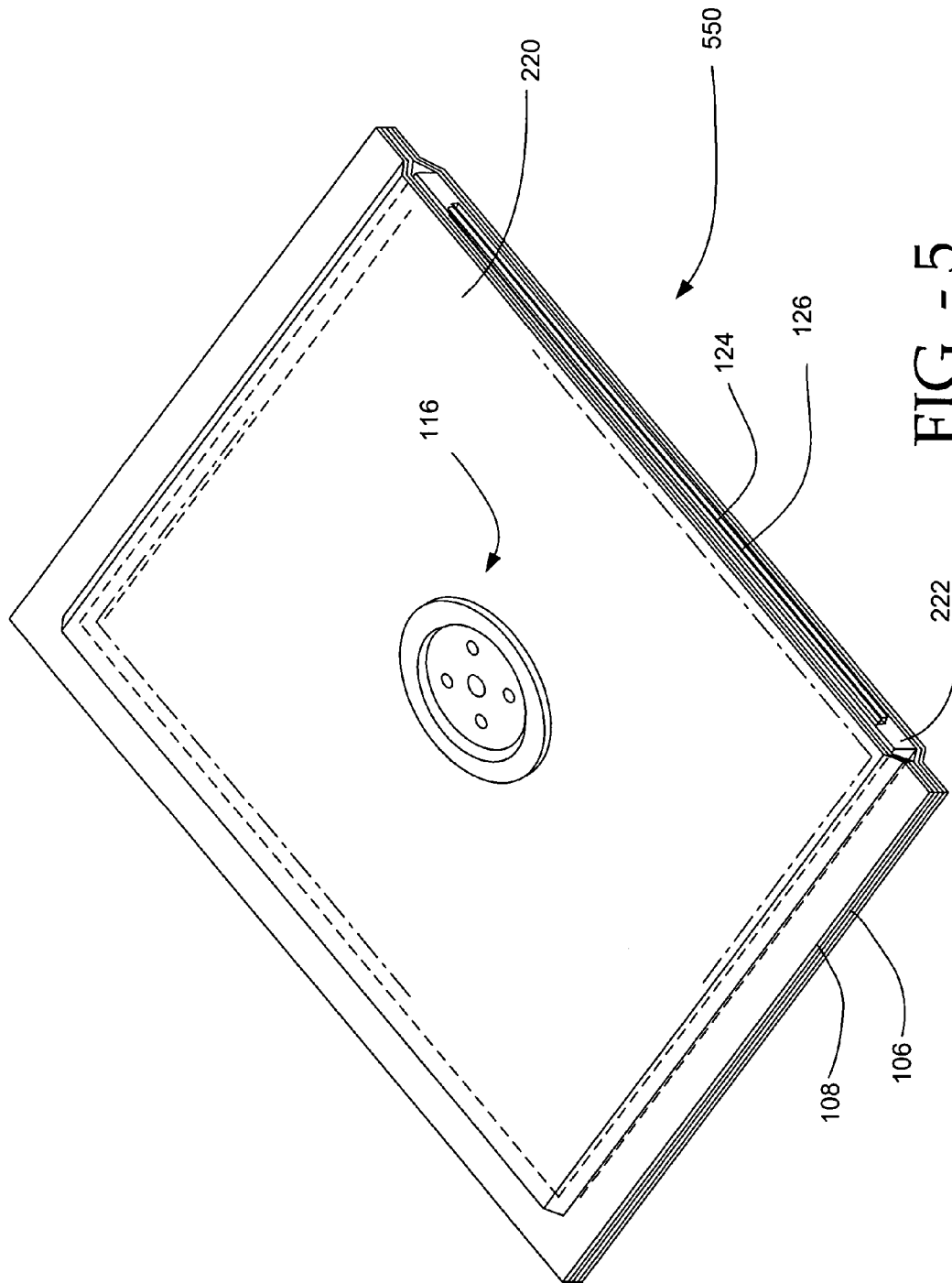

FIG. - 5

SEALABLE BAG HAVING AN INTEGRATED VALVE STRUCTURE FOR USE IN VACUUM PACKAGING

PRIORITY CLAIM

[0001] This application claims priority to the following U.S. Provisional Patent Application:

[0002] U.S. Provisional Patent Application No. 60/451,955, entitled "SEALABLE BAG HAVING AN INTEGRATED VALVE STRUCTURE FOR USE IN VACUUM PACKAGING," by Henry Wu, et al., filed Mar. 5, 2003 (Attorney Docket No. TILA-01181US0).

CROSS-REFERENCE TO RELATED PATENT APPLICATIONS

[0003] This U.S. patent application incorporates by reference all of the following co-pending applications:

[0004] U.S. Provisional Patent Application No. 60/452,168, entitled "LIQUID-TRAPPING BAG FOR USE IN VACUUM PACKAGING," by Henry Wu, et al., filed Mar. 5, 2003 (Attorney Docket No. TILA-01177US0);

[0005] U.S. Provisional Patent Application No. 60/452,138, entitled "METHOD FOR MANUFACTURING LIQUID-TRAPPING BAG FOR USE IN VACUUM PACKAGING," by Henry Wu, et al., filed Mar. 5, 2003 (Attorney Docket No. TILA-01177US1);

[0006] U.S. Provisional Patent Application No. 60/452,172, entitled "SEALABLE BAG HAVING AN INTEGRATED TRAY FOR USE IN VACUUM PACKAGING," by Henry Wu, et al., filed Mar. 5, 2003 (Attorney Docket No. TILA-01178US0);

[0007] U.S. Provisional Patent Application No. 60/452,171, entitled "METHOD FOR MANUFACTURING A SEALABLE BAG HAVING AN INTEGRATED TRAY FOR USE IN VACUUM PACKAGING," by Henry Wu, et al., filed Mar. 5, 2003 (Attorney Docket No. TILA-01178US1);

[0008] U.S. Provisional Patent Application No. 60/451,954, entitled "SEALABLE BAG HAVING AN INDICIA FOR USE IN VACUUM PACKAGING," by Henry Wu, et al., filed Mar. 5, 2003 (Attorney Docket No. TILA-01179US0);

[0009] U.S. Provisional Patent Application No. 60/451,948, entitled "METHOD FOR MANUFACTURING A SEALABLE BAG HAVING AN INDICIA FOR USE IN VACUUM PACKAGING," by Henry Wu, et al., filed Mar. 5, 2003 (Attorney Docket No. TILA-01179US1);

[0010] U.S. Provisional Patent Application No. 60/452,142, entitled "SEALABLE BAG HAVING AN INTEGRATED ZIPPER FOR USE IN VACUUM PACKAGING," by Henry Wu, et al., filed Mar. 5, 2003 (Attorney Docket No. TILA-01180US0);

[0011] U.S. Provisional Patent Application No. 60/452,021, entitled "METHOD FOR MANUFACTURING A SEALABLE BAG HAVING AN INTE-

GRATED ZIPPER FOR USE IN VACUUM PACKAGING," by Henry Wu, et al., filed Mar. 5, 2003 (Attorney Docket No. TILA-0180US1);

[0012] U.S. Provisional Patent Application No. 60/451,956, entitled "METHOD FOR MANUFACTURING A SEALABLE BAG HAVING AN INTEGRATED VALVE STRUCTURE FOR USE IN VACUUM PACKAGING," by Henry Wu, et al., filed Mar. 5, 2003 (Attorney Docket No. TILA-01181US1);

[0013] U.S. Provisional Patent Application No. 60/452,157, entitled "SEALABLE BAG HAVING AN INTEGRATED TIMER/SENSOR FOR USE IN VACUUM PACKAGING," by Henry Wu, et al., filed Mar. 5, 2003 (Attorney Docket No. TILA-01182US0);

[0014] U.S. Provisional Patent Application No. 60/452,139, entitled "METHOD FOR MANUFACTURING A SEALABLE BAG HAVING AN INTEGRATED TIMER/SENSOR FOR USE IN VACUUM PACKAGING," by Henry Wu, et al., filed Mar. 5, 2003 (Attorney Docket No. TILA-01182US1);

[0015] U.S. patent application Ser. No. 10/169,485, entitled "METHOD FOR PREPARING AIR CHANNEL EQUIPPED FILM FOR USE IN VACUUM PACKAGE," filed Jun. 26, 2002;

[0016] U.S. patent application Ser. No. _____, entitled "LIQUID-TRAPPING BAG FOR USE IN VACUUM PACKAGING," Attorney Docket No. TILA-01177US2, filed concurrently;

[0017] U.S. patent application Ser. No. _____, entitled "METHOD FOR MANUFACTURING LIQUID-TRAPPING BAG FOR USE IN VACUUM PACKAGING," Attorney Docket No. TILA-01177US3, filed concurrently;

[0018] U.S. patent application Ser. No. _____, entitled "SEALABLE BAG HAVING AN INTEGRATED TRAY FOR USE IN VACUUM PACKAGING," Attorney Docket No. TILA-01178US2, filed concurrently;

[0019] U.S. patent application Ser. No. _____, entitled "METHOD FOR MANUFACTURING A SEALABLE BAG HAVING AN INTEGRATED TRAY FOR USE IN VACUUM PACKAGING," Attorney Docket No. TILA-01178US3, filed concurrently;

[0020] U.S. patent application Ser. No. _____, entitled "SEALABLE BAG HAVING AN INDICIA FOR USE IN VACUUM PACKAGING," Attorney Docket No. TILA-01179US2, filed concurrently;

[0021] U.S. patent application Ser. No. _____, entitled "METHOD FOR MANUFACTURING A SEALABLE BAG HAVING AN INDICIA FOR USE IN VACUUM PACKAGING," Attorney Docket No. TILA-01179US3, filed concurrently;

[0022] U.S. patent application Ser. No. _____, entitled "SEALABLE BAG HAVING AN INTE-

GRATED ZIPPER FOR USE IN VACUUM PACKAGING,” Attorney Docket No. TILA-01180US2, filed concurrently;

[0023] U.S. patent application Ser. No. _____, entitled “METHOD FOR MANUFACTURING A SEALABLE BAG HAVING AN INTEGRATED ZIPPER FOR USE IN VACUUM PACKAGING,” Attorney Docket No. TILA-0180US3, filed concurrently;

[0024] U.S. patent application Ser. No. _____, entitled “METHOD FOR MANUFACTURING A SEALABLE BAG HAVING AN INTEGRATED VALVE STRUCTURE FOR USE IN VACUUM PACKAGING,” Attorney Docket No. TILA-01181US3, filed concurrently;

[0025] U.S. patent application No. _____, entitled “SEALABLE BAG HAVING AN INTEGRATED TIMER/SENSOR FOR USE IN VACUUM PACKAGING,” Attorney Docket No. TILA-01182US2, filed concurrently; and

[0026] U.S. patent application No. _____, entitled “METHOD FOR MANUFACTURING A SEALABLE BAG HAVING AN INTEGRATED TIMER/SENSOR FOR USE IN VACUUM PACKAGING,” Attorney Docket No. TILA-01182US3, filed concurrently.

FIELD OF THE INVENTION

[0027] The present invention relates to bags for use in vacuum packaging and methods and devices for manufacturing bags for use in vacuum packaging.

BACKGROUND

[0028] Methods and devices for preserving perishable foods such as fish and meats, processed foods, prepared meals, and left-overs, and non-perishable items are widely known, and widely varied. Foods are perishable because organisms such as bacteria, fungus and mold grow over time after a food container is opened and the food is left exposed to the atmosphere. Most methods and devices preserve food by protecting food from organism-filled air. A common method and device includes placing food into a gas-impermeable plastic bag, evacuating the air from the bag using suction from a vacuum pump or other suction source, and tightly sealing the bag.

[0029] A bag for use in vacuum packaging can consist of a first panel and second panel, each panel consisting of a single layer of heat-sealable, plastic-based film (for example, polyethylene). The panels are sealed together along a substantial portion of the periphery of the panels by heat-sealing techniques so as to form an envelope. Perishable products, such as spoilable food, or other products are packed into the envelope via the unsealed portion through which air is subsequently evacuated. After perishable products are packed into the bag and air is evacuated from the inside of the bag, the unsealed portion is heated and pressed such that the panels adhere to each other, sealing the bag.

[0030] U.S. Pat. No. 2,778,173, incorporated herein by reference, discloses a method for improving the evacuation of air from the bag by forming channels in at least one of the panels with the aid of embossing techniques. Air escapes

from the bag along the channels during evacuation. The embossing forms a pattern of protuberances on at least one of the panels. The protuberances can be discrete pyramids, hemispheres, etc., and are formed by pressing a panel using heated female and male dies. The first panel is overlaid on the second panel such that the protuberances from one panel face the opposite panel. The contacting peripheral edges of the panels are sealed to each other to form an envelope having an inlet at an unsealed portion of the periphery. The perishable or other products are packed into the envelope through the inlet, and the inlet is sealed. Thereafter, an opening is pierced in a part of the panel material that communicates with the channels, air is removed from the interior of the envelope through the channels and opening, and the opening is sealed. This type of bag requires two additional sealing steps after the perishable or other product is packed into the envelope. One further problem is that embossing creates impressions on the plastic such that indentations are formed on the opposite side of the panel

[0031] To avoid additional sealing steps, a vacuum bag is formed having a first panel and a second panel consisting of laminated films. Each panel comprises a heat-sealable inner layer, a gas-impermeable outer layer, and optionally, one or more intermediate layers. Such a bag is described in U.S. Pat. No. Re. 34,929, incorporated herein by reference. At least one film from at least one panel is embossed using an embossing mold to form protuberances and channels defined by the space between protuberances, so that air is readily evacuated from the vacuum bag.

[0032] U.S. Pat. No. 5,554,423, incorporated herein by reference, discloses still another bag usable in vacuum packaging. The bag consists of a first and second panel, each panel consisting of a gas-impermeable outer layer and a heat-sealable inner layer. A plurality of heat-sealable strand elements are heat bonded at regular intervals to the inner layer of either the first panel or the second panel. The spaces between strand elements act as channels for the evacuation of air. The strand elements are extruded from an extrusion head and heat bonded to the heat-sealable layer by use of pressure rolls. Separate equipment is required for producing strand elements, and a procedure of heat bonding a plurality of strand elements at regular intervals to the heat-sealable inner layer is complicated. Also, various shapes of pattern are hard to form using this process.

BRIEF DESCRIPTION OF THE FIGURES

[0033] Further details of embodiments of the present invention are explained with the help of the attached drawings in which:

[0034] FIG. 1A is a perspective view of a method for manufacturing a vacuum bag in accordance with one embodiment of the present invention;

[0035] FIG. 1B is a side view of the method shown in FIG. 1A illustrating the embossing method used in an embodiment of the present invention;

[0036] FIG. 1C is a close-up view of a portion of FIG. 1B for forming a receiving feature and an insertion feature;

[0037] FIG. 1D is a close-up view of a portion of FIG. 1B for forming a valve structure;

[0038] FIGS. 2A and 2B are cross-sections of portions of exemplary first panels overlapping exemplary second panels

in accordance with embodiments of the present invention, manufactured by the process shown in FIGS. 1A-C;

[0039] FIG. 2C is a perspective cross-section of a portion of an exemplary first panel overlapping a portion of exemplary second panel in accordance with an alternative embodiment of the present invention;

[0040] FIG. 2D is a perspective view of a portion of a first panel having a valve structure in accordance with one embodiment of the present invention, manufactured by the process shown in FIGS. 1A, 1B, and 1D;

[0041] FIG. 2E is a cross-section of the portion of a first panel shown in FIG. 2D;

[0042] FIG. 3 is a cross-section of a vacuum attachment connected with a portion of a vacuum bag and a diaphragm connected with the valve structure of FIGS. 2D and 2E;

[0043] FIGS. 4A and 4B are cross-sections of a portion of a first panel having a relief valve structure in accordance with one embodiment of the present invention;

[0044] FIGS. 4C and 4D are cross-sections of a portion of a first panel having a whimsical structure in accordance with one embodiment of the present invention; and

[0045] FIG. 5 is a perspective view of a vacuum bag in accordance with one embodiment of the present invention.

DETAILED DESCRIPTION

[0046] FIGS. 1A-D illustrate one embodiment of a method for manufacturing a vacuum bag in accordance with the present invention. The vacuum bag comprises a first panel and a second panel, wherein each panel comprises a gas-impermeable base layer 108 and a heat-sealable inner layer 106 with one panel having a receiving feature 126 and one panel having an insertion feature 124, the receiving feature and insertion feature together forming a zipper or clasp for sealing the vacuum bag. At least one of the panels can also include a valve structure 116 for evacuating the vacuum bag. A laminating roll 102 and a cooling roll 104 are arranged so that the heat-sealable inner layer 106 can be laminated to the gas-impermeable base layer 108 as the melt-extruded resin is cooled. As illustrated in FIG. 1B, the gap between the laminating roll 102 and the cooling roll 104 can be controlled according to specifications (for example, thickness) of a panel for use in vacuum packaging. The temperature of the cooling roll 104 is maintained in a range such that the melt-extruded resin is sufficiently cooled to form the desired pattern. For example, a temperature range of about -15° C. to about -10° C. can be sufficient to properly form the desired pattern. The temperature range of the cooling roll 104 can vary according to the composition of the resin, the composition of the gas-impermeable base layer 108, environmental conditions, etc. and can require calibration. Also, the cooling roll 104 can be sized to have a larger diameter than the laminating roll 102, thereby bringing the melt-extruded resin into contact with more cooled surface area. For example, the diameter of the cooling roll 104 can be about one-and-a-half to about three times as large (or more) as that of the laminating roll 102.

[0047] The heat-sealable inner layer 106 typically comprises a thermoplastic resin. For example, the heat-sealable inner layer can be comprised of polyethylene (PE) suitable for preserving foods and harmless to a human body. A

vacuum bag can be manufactured by overlapping a first panel with a second panel such that the heat-sealable inner layers 106 of the two panels are brought into contact, and by thereafter heating a portion of the periphery of the panels to form an envelope. The thermoplastic resin can be chosen so that the two panels strongly bond to each other when sufficient heat is applied.

[0048] The gas-impermeable base layer 108 is fed to the gap between the cooling roll 104 and the laminating roll 102 by a feeding means (not shown). The gas-impermeable base layer can be comprised of polyester, polyamide, ethylene vinyl alcohol (EVOH), nylon, or other material having similar properties and capable of being used in this manufacturing process, and also capable of being heated. The gas-impermeable base layer 108 can consist of one layer, or two or more layers. When employing a multilayer-structured base layer, it should be understood that a total thickness thereof is also adjusted within the allowable range for the total gas-impermeable base layer 108.

[0049] An extruder 110 is positioned in such a way that the melt-extruded resin is layered on the gas-impermeable base layer 108 by feeding the melt-extruded resin to the nip between the cooling roll 104 and the gas-impermeable layer 108. The resin is fed through a nozzle 112 of the extruder 110. The temperature of the melt-extruded resin is dependent on the type of resin used, and can typically range from about 200° C. to about 250° C. The amount of resin to be extruded into the laminating unit 100 is dependent on the desired thickness of the heat-sealable inner layer 106.

[0050] As shown partially in FIG. 1C, portions of a circumferential surface of the cooling roll 104 in accordance with one embodiment of the present invention can include cavities 184 corresponding to insertion features and/or protuberances corresponding to receiving features. The resin extruded from the nozzle 112 is pressed between the cooling roll 104 and the gas-impermeable base layer 108 and flows into the cavities 184 corresponding to insertion features, while being forced out of spaces corresponding to receiving features. In other embodiments, both the insertion features and receiving features can correspond to cavities 184. The resin quickly cools and solidifies in the desired pattern while adhering to the gas-impermeable base layer 108, thereby forming the heat sealable inner layer 106 of the panel as shown in FIG. 2A-C. The heat-sealable inner layer 106 can be formed while the resin is sufficiently heated to allow the resin to flow, thereby molding the resin, unlike other methods adopting a post-embossing treatment where the heat-sealable inner layer is drawn by a die or embossed between male and female components.

[0051] As shown partially in FIG. 1D, portions of the circumferential surface of the cooling roll 104 can additionally include, or can alternatively include, protuberances 186 and/or cavities 184 for forming a complicated structure, such as a valve structure 116. The resin extruded from the nozzle 112 is pressed between the cooling roll 104 and the gas-impermeable base layer 108. The resin flows into the cavities of the cooling roll 104 and is squeezed out where protuberances of the cooling roll 104 press into the resin. A circumferential surface of the laminating roll 102 can also, if desired, have cavities 180 and/or protuberances 182 for further defining features of the valve structure 116. As the melt-extruded resin is pressed between the cooling roll 104

and laminating roll **102**, the resin forces the gas-impermeable layer **108** to conform to the textured contour of the laminating roll **102**. The resin quickly cools and solidifies in the desired pattern while adhering to the gas-impermeable base layer **108**, thereby forming the heat-sealable inner layer **106** of the panel **220** as shown in **FIGS. 2D and 2E**. The circumferential surfaces of the cooling rolls **104** described above can optionally include protuberances for forming perforations (not shown), such that a bag can be separated from a roll of bags by a customer.

[**0052**] A laminating roll **102** having cavities **180** and/or protuberances **182** can have a circumference that is an integer multiple of the circumference of the cooling roll **104**, thereby defining a minimum number of panels produced in one rotation of the cooling roll **104**. For example, where a cooling roll **104** having a 36 inch circumference is used, the laminating roll **102** can have a circumference of 36 inches, 24 inches, 12 inches, etc., such that the circumference of the laminating roll **102** limits the maximum size of the bag.

[**0053**] The thickness (or depth) of each receiving or insertion feature formed on the heat-sealable inner layer of a panel **220** can be determined by the depth of the cavities or the height of the protuberances of the cooling roll **104**. The dimensions of the valve structure formed on the heat-sealable resin layer of a panel **220** can be determined by the depth of the cavities and the height of the protuberances of the cooling roll **104** and the laminating roll **102**. Thus, the shape, width, and thickness of the panels can be controlled by changing the specifications for the protuberances and cavities on one or both of the two rolls.

[**0054**] **FIG. 2A** illustrates a cross-section of two panels **220,222** in accordance with one embodiment of the present invention wherein the cavities of the cooling roll **104** correspond to an insertion feature **124** on the heat-sealable inner layer **106**, and wherein protuberances on other portions of the cooling roll **104**, or on a second cooling roll **104** correspond to a receiving feature **126** on the heat-sealable inner layer **106**. The receiving feature **126** is shaped to receive the insertion feature **124**, such that the features can be removably joined. Where the insertion feature **124** and receiving feature **126** are molded from the same cooling roll **104**, a single panel is folded over itself to form two panels **220,222**. Alternatively, each panel **220,222** can be formed separately using separate cooling rolls **104**. The features **124,126** form a zipper or clasp adapted for sealing the bag.

[**0055**] In an alternative embodiment shown in **FIG. 2B**, cavities of the cooling roll **104** correspond to both an insertion feature **124** and a receiving feature **126**. The receiving feature **126** is a protruding jaw shaped for receiving the insertion feature **124**, such that the features can be removably joined. The features **124,126** form a zipper or clasp adapted for sealing the bag. As described above, the features **124,126** can be molded by a single cooling roll **104**, or by two different cooling rolls **104**.

[**0056**] **FIG. 2C** is a perspective view of a cross-section of two panels **220,222** in accordance with still another embodiment of the present invention wherein cavities in the cooling roll **104** form protuberances corresponding to "teeth" **124** on the heat-sealable inner layer **106** for each panel, such that the teeth on a first panel **220** are offset from the teeth of a second panel **222**, so that the teeth mate. The teeth **124** form a zipper adapted for sealing the bag. One of ordinary skill in the art

can appreciate the different methods for forming mating components on two panels **220,222** such that a seal can be created and can appreciate the myriad of different feature geometries and arrangements for zipping or clasping a vacuum bag in accordance with the present invention.

[**0057**] The heat-sealable inner layer **106** can range from 0.5-6.0 mils in thickness and each insertion or receiving feature **124,126** can range from 0.5-8.0 mils in thickness, while the gas-impermeable base layer **108** can range from about 0.5-8.0 mils in thickness. The dimensions of the resin layer **106** and the base layer **108** are set forth to illustrate, but are not to be construed to limit the dimensions. In other embodiments, each panel **220,222** can include one or more receiving features **126** and/or one or more insertion features **124** such that the respective features of a first panel **220** mate with the respective features of a second panel **222**.

[**0058**] **FIG. 2D** is a perspective view of a portion of the panel **220** formed by the cooling roll **104** in which the heat-sealable inner layer **106** is molded in such a way that a valve structure **116** is formed in accordance with one embodiment of the present invention. The panel **220** can include a valve collar **230** for connecting a vacuum attachment with the valve structure **116** such that the vacuum attachment does not slide across the surface of the panel **220**. The panel **220** can also include at least one aperture **232** for drawing air and/or other gases from the bag during evacuation of the bag, and at least one attachment point **234** for connecting a diaphragm with the valve structure **116**. The cooling roll **104** can include pointed protuberances that extend as shown in **FIG. 1D** such that the protuberances pierce the gas-impermeable layer and are received in indentations of the laminating roll **102** when forming the at least one aperture **232**. The apertures **232** are shown in **FIGS. 2D and 2E** to be circular in shape and positioned equidistant from the center of the valve structure **116**, but in other embodiments can have different shapes and can be arranged in different patterns. **FIG. 2E** is a cross-section of the valve structure **116** shown in **FIG. 2D**, showing stiffeners **236** adapted for preventing portions of the bag from being sucked into any of the apertures **232** during evacuation and for providing additional rigidity to the valve structure. In the embodiment shown in **FIG. 2E**, the stiffeners **236** extend from the valve structure **116** on the underside of the valve and are positioned as a ring located about the apertures **232**. However, in other embodiments the stiffeners **236** can have various other geometries or can be absent.

[**0059**] **FIG. 3** is a cross-section of a portion of a vacuum bag **350** including a valve structure in accordance with one embodiment of the present invention. A diaphragm **338** can be connected with the bag **350** via the attachment point **234**. The diaphragm **338** can comprise a deformable material, for example rubber, such that a seal can be formed when a pressure differential between the inside and outside of the bag **350** creates suction on the diaphragm **338**, drawing the diaphragm **338** toward the one or more apertures **232**, but wherein the seal can be broken when a user places his finger between the diaphragm **338** and the valve structure **116**, or when a pressure differential creates suction on the diaphragm **338** drawing the diaphragm **338** away from the one or more apertures **232**. The diaphragm **338** can be dome-shaped, as shown in **FIG. 3**, or can be flat. A vacuum attachment **340** can be positioned around the valve collar **230** and air and/or other gases can be evacuated from the bag

350 by suction created by a vacuum source (not shown) connected with the vacuum attachment **340**. The vacuum attachment **340** can optionally include a check valve **342** for preventing liquids from being drawn into the vacuum source. Once the bag **350** has been sufficiently evacuated to suit the user's needs, the vacuum source is removed and the diaphragm **338** is drawn toward the one or more apertures **232** such that a seal is formed and the bag **350** remains partially or fully evacuated. The vacuum attachment **340** can be removed and the bag **350** stored for later use.

[0060] The heat-sealable inner layer **106** can range from 0.5-6.0 mils in thickness and the valve structure **116** can range from 0.5-80.0 mils or more in thickness, while the gas-impermeable base layer **108** can range from about 0.5-8.0 mils in thickness. The dimensions of the resin layer **106** and the base layer **108** are set forth to illustrate, but are not to be construed to limit the dimensions.

[0061] In other embodiments, the valve structure **116** can be a simple flat structure having one or more apertures **232** and one or more attachment points **234**, thereby eliminating the need for a laminating roll **102** having surface topography, simplifying the manufacturing process. One of ordinary skill in the art can appreciate the myriad of different shapes and features a valve structure can have.

[0062] In still other embodiments, a different valve structure can be formed or a structure other than a valve structure can be formed. For example, as shown in **FIGS. 4A and 4B**, the structure can be a release valve wherein applying pressure to a dome-shaped diaphragm **338** connected with the bag at an attachment point **234** causes a seal to be broken, allowing air **448** (shown schematically) to enter or be evacuated from the bag through apertures **232**. In still other embodiments, a recessed area similar to that of the valve structure can include an emblem, or a whimsical feature such as a propeller **444** connected with an attachment point **234** and adapted to rotate when a seal is broken and air rushes into a partially evacuated bag (as shown in **FIGS. 4C and 4D**).

[0063] **FIG. 5** illustrates a bag for use in vacuum packaging in accordance with one embodiment of the present invention. The bag **550** comprises a first panel **220** overlapping a second panel **222**, each panel comprising a heat-sealable inner layer **106** and an outer, gas-impermeable base layer **108**. At least one receiving feature **126** is formed on the first panel **220** in accordance with an embodiment described above. At least one insertion feature **124** is formed on the second panel **222** in accordance with an embodiment described above, such that the insertion feature **124** can be mated with the receiving feature **126** to form a seal. In other embodiments, each panel can have a plurality of insertion features and receiving features, such that a more secure seal can be obtained. A valve structure **116** is formed on at least one panel **220,222**. As described above, in other embodiments, a single panel **220** can be formed having an insertion feature **124**, a receiving feature **126**, and a valve structure **116** such that the panel **220** can be folded over itself to form the bag **550**, thereby reducing tooling costs through the use of a single cooling roll **104**.

[0064] The lower, left, and right edges of the overlapped first and the second panel **220,222** are bonded to each other by heating, so as to form an envelope for receiving a perishable or other product to be vacuum packaged. A

perishable or other product can be packed in the bag through an inlet. The inlet can be sealed by the zipper or clasp, and the air and/or gases can then be evacuated through the valve structure. The seal can be broken by unfastening the zipper or clasp. In this way, the vacuum bag **550** can be repeatedly used. In other embodiments, a zipper or clasp is not included and the inlet is heat sealed. In still other embodiments, the bag **550** can include insertion and receiving features **124,126** but no valve structure **116**.

[0065] The features and structures described above can be combined with other manufacturing techniques to form indicia or integrated temperature sensors, as described in the cross-referenced provisional applications, incorporated herein by reference.

[0066] The foregoing description of preferred embodiments of the present invention has been provided for the purposes of illustration and description. It is not intended to be exhaustive or to limit the invention to the precise forms disclosed. It is to be understood that many modifications and variations will be apparent to the practitioner skilled in the art. The embodiments were chosen and described in order to best explain the principles of the invention and its practical application, thereby enabling others skilled in the art to understand the invention for various embodiments and with various modifications that are suited to the particular use contemplated. It is intended that the scope of the invention be defined by the following claims and their equivalence.

1. A bag adapted to receive an article, comprising:
 - a first panel defining at least one molded portion;
 - a second panel; and
 - the first panel and the second panel secured together to form the bag;
 - wherein the at least one molded portion is a valve structure.
2. A bag adapted to receive an article, comprising:
 - a first panel having:
 - a first outer layer; and
 - a first inner layer connected with the first outer layer, the first inner layer including at least one molded portion integrally formed with the first inner layer;
 - wherein the at least one molded portion comprises a valve structure; and
 - a second panel connected with the first panel such that the first panel and the second panel form an envelope having an inlet, the second panel having:
 - a second outer layer; and
 - a second inner layer connected with the second outer layer.
3. The bag of claim 2, wherein the valve structure includes:
 - a collar adapted for receiving a vacuum attachment;
 - at least one aperture within the collar, adapted for communicating air between an inside of the bag and an outside of the bag; and
 - at least one attachment point adapted for receiving a diaphragm for sealing the at least one aperture.

- 4. The bag of claim 3, further comprising:
a diaphragm connected with the at least one attachment point.
- 5. The bag of claim 3, wherein the first panel further comprises at least one receiving feature and wherein the second panel further comprises at least one insertion feature removably connectable with the at least one receiving feature.
- 6. The bag of claim 2, wherein the first outer layer and the second outer layer comprise a gas-impermeable material.
- 7. The bag of claim 6, wherein the gas-impermeable material is one of polyester, polyamide, ethylene vinyl alcohol, and nylon.
- 8. The bag of claim 2, wherein the first inner layer and the second inner layer comprise a thermoplastic resin.
- 9. The bag of claim 8, wherein the thermoplastic resin is polyethylene.
- 10. A bag adapted to receive an article, comprising:
a first panel including:
a first gas-impermeable layer; and
a first inner layer laminated to the first gas-impermeable layer, the first inner layer having a textured exposed surface;
wherein the textured exposed surface is a valve structure; and
a second panel including:
a second gas-impermeable layer; and
a second inner layer laminated to the second gas-impermeable layer;
wherein the first panel is connected with the second panel to form an envelope such that the first inner layer opposes the second inner layer, the envelope including a heat-sealable opening for evacuating gas.
- 11. The bag of claim 10, wherein the valve structure includes:
a collar adapted for receiving a vacuum attachment;
at least one aperture within the collar, adapted for communicating air between an inside of the bag and an outside of the bag; and
at least one attachment point adapted for receiving a diaphragm for sealing the at least one aperture.
- 12. The bag of claim 11, further comprising:
a diaphragm connected with the at least one attachment point.
- 13. The bag of claim 10, wherein the first gas-impermeable layer and the second gas-impermeable layer comprise one of polyester, polyamide, ethylene vinyl alcohol, and nylon.
- 14. The bag of claim 10, wherein the first inner layer and the second inner layer comprise a thermoplastic resin.
- 15. The bag of claim 14, wherein the thermoplastic resin is polyethylene.

- 16. A heat-sealable bag adapted to receive an article, comprising:
a first panel including:
a first gas-impermeable layer;
at least one first intermediate layer connected with the first gas-impermeable layer; and
a first inner layer laminated to the at least one first intermediate layer, the first inner layer having a textured exposed surface;
wherein the textured exposed surface is a valve structure; and
a second panel including:
a second gas-impermeable layer;
at least one second intermediate layer connected with the second gas-impermeable layer; and
a second inner layer laminated to the at least one second intermediate layer;
wherein the first panel is connected with the second panel to form an envelope such that the first inner layer opposes the second inner layer, the envelope including a heat-sealable opening for evacuating gas.
- 17. The bag of claim 16 wherein the valve structure includes:
a collar adapted for receiving a vacuum attachment;
at least one aperture within the collar, adapted for communicating air between an inside of the bag and an outside of the bag; and
at least one attachment point adapted for receiving a diaphragm for sealing the at least one aperture.
- 18. The bag of claim 17, further comprising:
a diaphragm connected with the at least one attachment point.
- 19. The bag of claim 16, wherein the first gas-impermeable layer and the second gas-impermeable layer comprise one of polyester, polyamide, ethylene vinyl alcohol, and nylon.
- 20. The bag of claim 16, wherein the first inner layer and the second inner layer comprise a thermoplastic resin.
- 21. The bag of claim 20, wherein the thermoplastic resin is polyethylene.
- 22. A system for forming a bag including a three-dimensional structure formed on at least one panel, comprising:
a cooling roll having one or more structures for forming one or more indicia;
a laminating roll;
a backing material; and
a flowable material that can be flowed into the one or more structures to form the one or more indicia, the one or more indicia adhering to the backing material.

* * * * *