

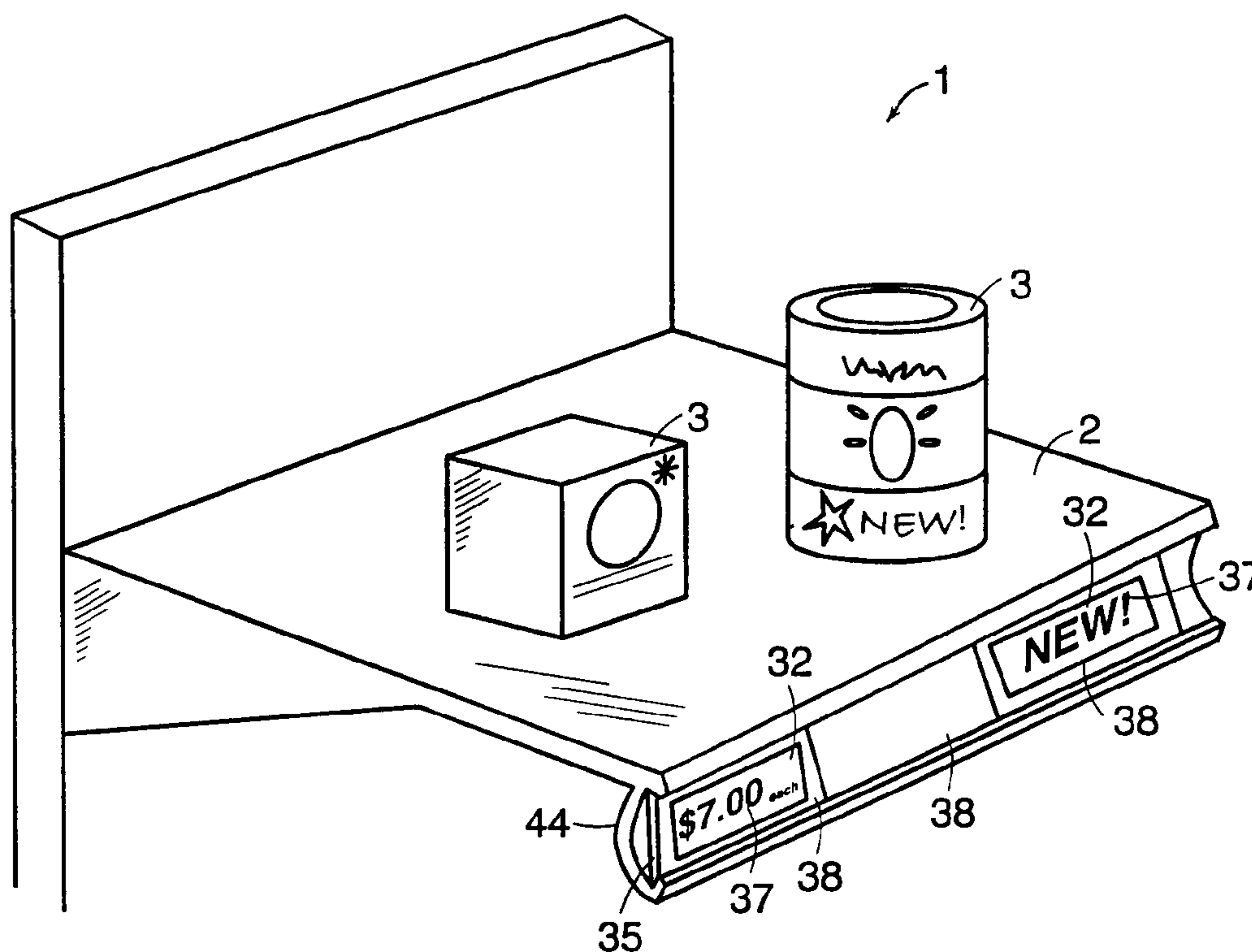

(86) Date de dépôt PCT/PCT Filing Date: 2000/05/03
 (87) Date publication PCT/PCT Publication Date: 2000/11/09
 (85) Entrée phase nationale/National Entry: 2001/10/30
 (86) N° demande PCT/PCT Application No.: US 2000/012003
 (87) N° publication PCT/PCT Publication No.: 2000/067110
 (30) Priorité/Priority: 1999/05/03 (60/132,178) US

(51) Cl.Int.⁷/Int.Cl.⁷ G06F 3/147
 (71) Demandeur/Applicant:
E INK CORPORATION, US
 (72) Inventeurs/Inventors:
WILCOX, RUSSELL J., US;
COMISKEY, BARRETT, US
 (74) Agent: SMART & BIGGAR

(54) Titre : UNITE D'AFFICHAGE POUR SYSTEME ELECTRONIQUE D'ETIQUETTES DE PRIX SUR PRESENTOIR
 (54) Title: DISPLAY UNIT FOR ELECTRONIC SHELF PRICE LABEL SYSTEM



(57) Abrégé/Abstract:

An electronic display unit for an electronic shelf price label ("ESPL") system is disclosed that draws substantially no power to maintain the display. The electronic display unit comprises an updateable bistable electrophoretic display medium for displaying information and at least one electrode. In addition, the electronic display unit may be in electrical communication with an information updating unit. The information updating unit updates the information displayed by the display unit in response to a control signal or an environmental condition. The electronic display unit is capable of: (1) being manufactured by printing techniques; (2) being made in a lightweight and flexible form; and (3) holding an image power draw.



PCT

WORLD INTELLECTUAL PROPERTY ORGANIZATION
International Bureau

INTERNATIONAL APPLICATION PUBLISHED UNDER THE PATENT COOPERATION TREATY (PCT)

(51) International Patent Classification ⁷ : G06F 3/147	A1	(11) International Publication Number: WO 00/67110 (43) International Publication Date: 9 November 2000 (09.11.00)
<p>(21) International Application Number: PCT/US00/12003</p> <p>(22) International Filing Date: 3 May 2000 (03.05.00)</p> <p>(30) Priority Data: 60/132,178 3 May 1999 (03.05.99) US</p> <p>(71) Applicant: E INK CORPORATION [US/US]; 733 Concord Avenue, Cambridge, MA 02138 (US).</p> <p>(72) Inventors: COMISKEY, Barrett; 346 Putnam Avenue, Cambridge, MA 02139 (US). WILCOX, Russell, J.; 17 Winemay Street, Natick, MA 01760 (US).</p> <p>(74) Agent: LANZA, John, D.; Testa, Hurwitz & Thibault, LLP, High Street Tower, 125 High Street, Boston, MA 02110 (US).</p>	<p>(81) Designated States: AE, AG, AL, AM, AT, AU, AZ, BA, BB, BG, BR, BY, CA, CH, CN, CR, CU, CZ, DE, DK, DM, DZ, EE, ES, FI, GB, GD, GE, GH, GM, HR, HU, ID, IL, IN, IS, JP, KE, KG, KP, KR, KZ, LC, LK, LR, LS, LT, LU, LV, MA, MD, MG, MK, MN, MW, MX, NO, NZ, PL, PT, RO, RU, SD, SE, SG, SI, SK, SL, TJ, TM, TR, TT, TZ, UA, UG, UZ, VN, YU, ZA, ZW, ARIPO patent (GH, GM, KE, LS, MW, SD, SL, SZ, TZ, UG, ZW), Eurasian patent (AM, AZ, BY, KG, KZ, MD, RU, TJ, TM), European patent (AT, BE, CH, CY, DE, DK, ES, FI, FR, GB, GR, IE, IT, LU, MC, NL, PT, SE), OAPI patent (BF, BJ, CF, CG, CI, CM, GA, GN, GW, ML, MR, NE, SN, TD, TG).</p> <p>Published <i>With international search report. Before the expiration of the time limit for amending the claims and to be republished in the event of the receipt of amendments.</i></p>	

(54) Title: DISPLAY UNIT FOR ELECTRONIC SHELF PRICE LABEL SYSTEM

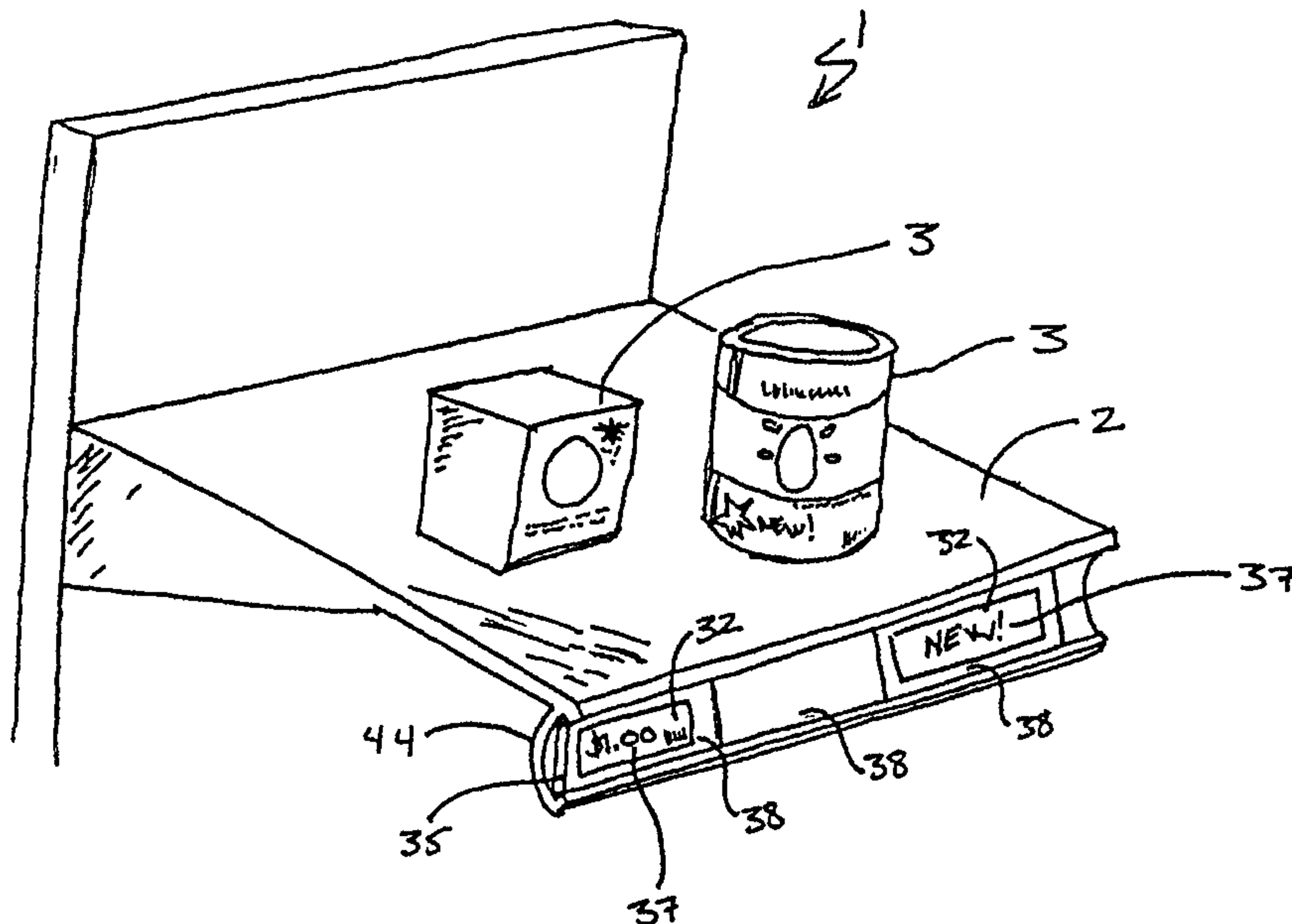

(57) Abstract

An electronic display unit for an electronic shelf price label ("ESPL") system is disclosed that draws substantially no power to maintain the display. The electronic display unit comprises an updateable bistable electrophoretic display medium for displaying information and at least one electrode. In addition, the electronic display unit may be in electrical communication with an information updating unit. The information updating unit updates the information displayed by the display unit in response to a control signal or an environmental condition. The electronic display unit is capable of: (1) being manufactured by printing techniques; (2) being made in a lightweight and flexible form; and (3) holding an image power draw.

DISPLAY UNIT FOR ELECTRONIC SHELF PRICE LABEL SYSTEM

Field of the Invention

The present invention relates to information display applications, and in particular, to the display of information concerning goods in a retail environment.

Cross Reference to Related Applications

5 The present application claims priority to and the benefit of United States provisional patent application serial number 60/132,178 filed May 3, 1999, the entire disclosure of which is incorporated herein by reference.

Background of the Invention

10 Modern retailing is under rising pressure to increase both the speed and accuracy with which it displays product information and price. The almost universal use of bar codes to identify both product type and price has enabled retailers to update the price of products from a central location and have that price automatically register when the bar code is scanned at the point-of-sale (POS). However, the speed with which retailers can update product information and price at the actual location where a product is displayed has not kept pace. The delay in
15 updating product information and pricing at the point-of-display (POD) can lead to a mismatch between the price a consumer has been lead to believe a product costs and the price registered at the POS. A consumer confronted with a different price at the POS is understandably annoyed, and adverse business or regulatory consequences may follow for the retailer.

20 The delay in updating product information and price at the POD most frequently arises from the need to manually update this information. Today, retail establishments typically display product information and price on labels in the form of adhesive tags, preprinted cards or plastic numbers. The label is usually affixed to the edge of the shelf or surface on which the product is located. These labels must necessarily be changed manually; a time consuming and labor intensive process subject to a variety of human errors. The cost and chance for error associated
25 with such manual change is compounded by the rapid change of product information and price, as well as location, in the modern retail establishment. The increasing use of such dynamic

- 2 -

pricing schemes such as yield management pricing can only increase the probability of POD and POS price mismatch.

A need therefore exists in the retail environment to replace a large majority of the manual activity in the change cycle of POD product information and price with an electronic method that is inexpensive and flexible enough to be economically viable.

Electronic shelf price label (ESPL) systems have been proposed for displaying at the POD continuously updateable prices. Electronic display units for an ESPL system have been developed which can be affixed to the edge of the shelf, and which optically indicate the price of the merchandise and perhaps additional information. The electronic display units are connected to a store computer which can easily update the price on the electronic display unit as well as at the POS. As a result, it can generally be guaranteed that the price at the POD is the same as the price which will be charged at the POS.

Several important technical problems have prevented the cost effective development of ESPL display systems. Invariably, these systems required a near continuous supply of power, either by line transmission, battery, capacitor, RF transmission, or other form of indirect power transmission. Many systems, to date, involve a hard-wired connection from the individual electronic display units to the power supply. The expense associated with installing and maintaining such hard-wire systems has hindered their economic viability. In addition, the goods on the shelves in most retail establishments are constantly being rearranged. Consequently any direct hard-wired system becomes an expensive impracticality. Wireless power transmission systems have been proposed where the electronic display units inductively receive the energy emitted by a transmitter to recharge an integrated or hardwired power source, e.g., a battery. Nevertheless, these systems also invariably require a near constant supply of power to maintain the display of the electronic display units.

To date, a major cost driver of ESPL systems has been the electronic display unit and associated communication electronics. In a traditional ESPL system, there is one wired emissive electronic display unit affixed to the shelf for each SKU. Due to the expense of a high-contrast, high-resolution emissive electronic display, only the price portion of the label is variable; the rest of the label, such as the bar code and SKU information, is printed and permanent. As a result, manual labor is required to move the electronic display units whenever the corresponding product is moved.

- 3 -

The benefits flowing from installation of a viable, workable ESPL system would be many. Prices could be displayed at the POD for each of the many products for sale, and the price, electronically displayed, could be made to match with high reliability the price registered when the product is scanned at the POS. Sales and “specials” could be posted, and later cleared, with a minimal labor cost as compared to the common manual method of updating POD information. Further, a viable, workable ESPL system that provides an electronic display with the mechanical compatibility of a printed display could truly satisfy the needs of the retail environment. Such a system, could almost instantaneously, and store wide, update each and every POD display unit, and quite possibly enable in-store marketing methods never before thought possible.

Summary of the Invention

An object of the present invention is to provide an electronic display unit for an ESPL system that is flexible and which requires substantially no power to maintain the display of the electronic display unit. In addition, the electronic display unit of the present invention features a printable electronic display comprising an encapsulated electrophoretic display medium. The resulting electronic display is flexible and has in large measure the applications of a printed display. Further, since the encapsulated electrophoretic display medium used in the present invention can be printed, the display itself can be made inexpensively.

The encapsulated electrophoretic display medium used in the present invention is an optoelectronically active material which comprises at least two phases: an electrophoretic contrast media phase and a coating/binding phase. The electrophoretic display medium can form, for example, a full color, multi-color, or two color (e.g. black and white) display. The electrophoretic phase comprises, in the present invention, at least one species of encapsulated electrophoretic particles, having distinct physical and electrical characteristics, dispersed in a clear or dyed suspending fluid. The coating/binding phase includes, in one embodiment, a polymer matrix that surrounds the electrophoretic phase. In this embodiment, the polymer in the polymeric binder is capable of being dried, crosslinked, or otherwise cured as in traditional inks, and therefore a printing process can be used to deposit the encapsulated electrophoretic display medium onto a substrate. Accordingly, hereinafter the term “electronic ink” is meant to refer to the encapsulated electrophoretic display medium used in the present invention.

- 4 -

The optical quality of an electronic ink is quite distinct from other electronic display materials. The most notable difference is that electronic ink provides a high degree of both reflectance and contrast because it is pigment based (as are ordinary printing inks). The light scattered from the electronic ink comes from a very thin layer close to the top of the viewing surface. In this respect it resembles a common printed image. Thus, electronic ink is easily viewed from a wide range of viewing angles in the same manner as a printed page. Such ink approximates a Lambertian contrast curve more closely than any other electronic display material. Since electronic ink can be printed, it can be included on the same surface with any other printed material. Electronic ink can be made optically stable in all optical states, that is, the ink can be set to a persistent optical state. An electronic ink display is particularly useful in low power applications because of this stability.

An electronic display that comprises electronic ink can be created so that the optical state of the electronic ink is stable for some length of time. When the electronic ink has two states which are stable in this manner, the electronic ink is said to be bistable. If more than two states of the electronic ink are stable, then the electronic ink can be said to be multistable. For the purpose of this invention, the term "bistable" will be used to indicate an electronic ink or electronic ink display in which any optical display state remains fixed once an electrical field applied across the electronic ink is removed. The definition of a bistable state depends on the application for the electronic ink. A slowly-decaying optical display state can be effectively bistable if the optical display state is substantially unchanged over the required viewing time. For example, in an electronic ink display which is updated every few minutes, a display image which is stable for hours or days is effectively bistable for that application. In this invention, the term "bistable" also indicates an electronic ink or electronic ink display with an optical display state sufficiently long-lived as to be effectively bistable for the application in mind. Whether or not an electronic ink is bistable, and its degree of bistability, can be controlled through appropriate chemical modification of the electrophoretic particles, the suspending fluid, the capsule, and coating/binding phase. Another advantage of an electronic ink display is that relatively poor conductors, for example, materials with resistivities on the order of $10^3 - 10^{12}$ ohms square, can be used as electrodes to apply an electric field to select portions of the electronic ink display, i.e., address a display element.

Electronic ink may be coated onto practically any surface using appropriate binders such as PVCs, urethanes and silicone binders, allowing electronic ink displays to be: (1) made in large

- 5 -

sizes (such as poster and billboard sizes) using coating techniques; (2) lightweight enough to install without an overhead crane; (3) flexible enough to bend with wind; and (4) capable of holding an image without further power draw, thereby operating economically from solar cells, batteries, or inductive power transmission.

5 There are many places in a retail environment where electronic ink provides a superior display. For example, an electronic ink can switches between various optical display states in order to communicate a condition of or information about a product. The condition or information could include, for example, whether an item is on sale or whether an item has been deactivated from an internal security system.

10 Electronic ink is ideal for application in an electronic display unit of an ESPL system. An electronic display unit comprised of an electronic ink display possess several advantages for use as a POD label: (1) the display is reflective, and as a result, has a wide field of view and high contrast; (2) the display can be made thin, and as a result, it be made both light weight and flexible; (3) the display can be printed, and as a result, can potentially be made for a low cost;
15 and (4) the display can be bistable, and as a result, it draws substantially no energy during display. For example, such an electronic display unit could be so thin as to fit within the standard channel groove provided on supermarket gondola shelving. Further, the display could be curved, either concave or convex, to provide a smooth yet attention-grabbing display. Additionally, such a display could be tilted at an angled from the vertical to provide for glare
20 reduction, and yet still maintain a shallow enough profile to avoid interfering with removal of product from the shelves.

 More importantly, the present invention provides a bistable electronic display unit, which requires substantially no power to maintain the display state, by taking advantage of the electrophoretic nature of the constituent electronic ink. As a result, the elaborate power
25 transmission systems of prior ESPL systems are not required for the electronic display units of the present invention. Accordingly, hereinafter the term “electrophoretic display unit” is meant to refer to the electronic display unit comprised of an electronic ink display of the present invention.

 Further, the terms “display state” and “optical display state” are meant to refer to the
30 visual appearance of the electronic ink display of an electrophoretic display unit. Accordingly, it is to be realized that the display state may present a visual appearance that includes, but is not limited to, such optical properties as color, reflectivity, or luminescence. Further, this visual

- 6 -

appearance may form a “message.” As used throughout the specification, the term “message” is intended to include any type of indicia such as a number, text, or an image, alone or in combination, that conveys information. The term message includes, but is not limited to, prices, letters, words, graphics, photos, logos, bar codes, and 2D bar codes. Consequently, it is to be understood that changing the message of an electrophoretic display unit entails changing the display state of the associated electronic ink of the unit.

In one aspect, the invention features a device for storing goods for sale (or rent). The device comprises a storage surface having a portion for supporting the goods and an extension for displaying information about the goods, and an electronic shelf label disposed adjacent the extension. The electronic shelf label comprises an electrophoretic display unit providing updateable information about the goods.

In one embodiment, the device for storing goods further comprises a substrate disposed adjacent the storage surface extension. The substrate comprises a strip having a plurality of segments in electrical communication with each other. At least one segment has an electrophoretic display unit displaying information about the goods. This strip may be used, for example, to highlight the shelf and draw attention to the goods thereon.

In one embodiment, the electronic ink of the electrophoretic display unit is electrostatically writable. In one embodiment, the storage surface is a shelf that further comprises a track along the extension and an electrostatic print head that moves along the track and automatically updates information about the goods.

In another embodiment, the device for storing goods further comprises a sensor in communication with an information updating unit, for receiving update signals, in electrical communication with an electrophoretic display unit. The sensor can comprise a microphone. Alternatively, the sensor can comprise an optical sensor. In one embodiment, the sensor comprises a photodiode. In another embodiment, the device further comprises a logic circuit updating the information displayed by the electrophoretic display media based on data received by the sensor. In another embodiment, the device further comprises a short-range radio antenna in electrical communication with the information updating unit. In various embodiments, the short-range radio antenna is capable of receiving data from a distance of no more than about 12 inches, 10 feet, or 100 feet. It is to be realized that the desired of the radio antenna will vary with the nature of the retail environment. For example, a lumber yard could benefit from an antenna

- 7 -

capable of receiving data from about 100 feet, whereas a corner grocery store might require an antenna capable of receiving data from only about 12 inches.

In another aspect, the invention features a method of updating information on an electronic shelf label. The method comprises the steps of: (a) providing an electrophoretic display unit comprising an electronic ink disposed on a first electrode; and (b) applying an electric field across the electronic ink to change the display state thereof. In one embodiment, step (a) comprises providing an electrophoretic display unit disposed on an extension of a shelf, where the shelf has a portion for supporting goods for sale and an extension for displaying information about the goods. In one detailed embodiment, step (a) further comprises providing a strip having a plurality of segments in electrical communication with each other, where at least one segment has an electrophoretic display unit disposed adjacent one surface of a segment that displays information about the goods. In one embodiment, step (b) comprises: (b1) receiving data for updating the information displayed on the electrophoretic display unit; and (b2) applying an electric field across the electronic ink based on the received data.

In another embodiment, step (a) comprises providing a first electrophoretic display unit in electrical communication with a second electrophoretic display unit; and step (b) comprises: (b1) transmitting data through short range radio signals from the first electrophoretic display unit to the second electrophoretic display unit; and (b2) applying an electric field across the electronic ink of the second electrophoretic display unit based on the transmitted data. In one embodiment, the method further comprises the step of receiving data from a central control station at the first electrophoretic display unit and subsequently re-transmitting the data from the first electrophoretic display unit to the second electrophoretic display unit.

In another embodiment, the method further comprises the step of using a portable activation device to update the information displayed on the electrophoretic display unit. In still another embodiment, the method further comprises the step of using an electrostatic printing device to update the information displayed on a electrophoretic display unit by moving the electrostatic device along a track disposed on a shelf extension on which the electrophoretic display unit is disposed and automatically updating information displayed on the electrophoretic display.

In addition, another object of the invention is to provide a store wide product information and price display system. In one embodiment, this system comprises electronic ink signage and an ESPL system of electrophoretic display units. The resulting store wide display system permits

- 8 -

a fully integrated system in which both electronic signage and electrophoretic display units are updateable from a single location. This system permits enhanced flexibility and adaptability in store signage while also ensuring store wide price consistency at the POD. In another embodiment, the store wide product information and price display system is further integrated with the store POS price data system. The resulting store wide display system permits a retailer to update product information and price from a single location while ensuring that the price a consumer has been lead to believe a product costs at the POD will match the price registered at the POS.

The invention herein focuses on the use of electronic ink to achieve beneficial effects in a retail environment. However, it is to be understood that such inventions could also be applied to analogous environments, including restaurants, banks, airports, health clubs, stadiums, and so forth; in short any space open to a number of people in which transactions are conducted, without departing from the spirit and scope of the present invention.

Brief Description of the Drawings

The invention is pointed out with particularity in the appended claims. The advantages of the invention described above, together with further advantages, may be better understood by referring to the following description taken in conjunction with the accompanying drawings. In the drawings, like reference characters generally refer to the same parts throughout the different views. Also, the drawings are not necessarily to scale, emphasis instead generally being placed upon illustrating the principles of the invention.

Figures 1A-1D illustrate various embodiments of a device for the electronic display of information on a storage surface that employ an electrophoretic display unit.

Figure 2A illustrates one embodiment of an electrophoretic display unit.

Figure 2B and 2C illustrate various embodiments of the electronic ink of an electrophoretic display unit.

Figures 2D-2G illustrate various embodiments of an electrophoretic display unit.

Figures 3A-3B illustrate one embodiment of a display state change of an electrophoretic display unit.

Figures 4A-4B illustrate various embodiments of a device for the electronic display of information on a storage surface comprising an electronic ink display strip.

- 9 -

Figures 5A-5C illustrate various embodiments of a device for the electronic display of information on a storage surface further comprising an information updating unit.

Figure 6 illustrates an embodiment of a store wide product information and price display system.

5 Detailed Description

According to the present invention, a goods storage surface with a portion for supporting goods and an extension for displaying information is provided and an electrophoretic display unit is disposed on the extension. Referring to FIGS. 1A-1D, various embodiments of a device for the electronic display of information on a storage surface are illustrated. Referring to FIGS. 1A and 1B, in one embodiment, a device for the electronic display of information on a storage surface 1 comprises a shelf 2 for supporting goods 3 and an extension 4 with an electrophoretic display unit 5 disposed thereon. As illustrated, in a preferred embodiment the extension 4 comprises the standard channel groove provided on a standard gondola-type shelf 2. In this embodiment, the electrophoretic display unit 5 is disposed on the extension by flexing the display unit so that the upper and lower edges 6 and 7 of the display unit fit into the recesses 8 and 9 of the extension channel. In FIG. 1A, the display unit 5 is flexed to form a convex display. Alternatively, as illustrated in FIG. 1B, the display unit 5 is flexed to form a concave display. Referring to FIG. 1C, in another embodiment, a device for the electronic display of information on a storage surface 11 comprises pegs 12 for supporting goods 13 and various extensions 14, 15 on which are disposed an electrophoretic display unit 16. As illustrated, the rack 12 is a standard pegboard type. Referring to FIG. 1D, in another embodiment, a device for the electronic display of information on a storage surface comprises a rack 22 for supporting goods 23 and various extensions 24, 25 on which are disposed an electrophoretic display unit 26. As illustrated, the rack 22 is a standard circular clothing rack. Accordingly, it is to be understood that the present invention provides a device for the electronic display of information that can be used on any standard retail display fixture.

According to the present invention, an electrophoretic display unit for an ESPL system, that can be both flexible and bistable, is provided. In a preferred embodiment, the display unit comprises an electronic ink printed on a substrate that forms a first electrode. An electronic ink is capable of being printed by several different processes, depending on the mechanical properties of the specific ink employed. For example, the fragility or viscosity of a particular ink

- 10 -

may result in a different process selection. A very viscous ink would not be well-suited to deposition by an inkjet printing process, while a fragile ink might not be used in a knife over roll coating process. Accordingly, it is to be understood that as used throughout the specification, printing is intended to include all forms of printing and coating, including: premetered coatings
5 such as patch die coating, slot or extrusion coating, slide or cascade coating, and curtain coating; roll coating such as knife over roll coating, forward and reverse roll coating; gravure coating; dip coating; spray coating; meniscus coating; spin coating; brush coating; air knife coating; silk screen printing processes; electrostatic printing processes; thermal printing processes; ink jet printing processes; and other similar techniques. Consequently, a "printed element" refers to an
10 element formed using any one of the above techniques.

There are multiple embodiments of electrophoretic display units that provide the advantages of the present invention. In one class of embodiments, electronic ink is disposed between a first electrode and a second electrode. Referring to FIG. 2A, one embodiment of a flexible, bistable electrophoretic display unit is illustrated. The electrophoretic display unit **100**
15 comprises electronic ink **102** disposed between a first electrode **103** and a transparent second electrode **104**. FIG. 2A depicts an embodiment of the electrode structure described above in which the second electrode **104** is on "top" of the electronic ink **102**, that is, electrode **104** is between the viewpoint **101** and the electronic ink **102**. The first electrode, the second electrode, or both, may form a pattern suitable for displaying product prices and/or information depending
20 on how the electrodes are addressed. The first electrode **103** may be fabricated from any flexible material capable of conducting electricity such that electrodes **103**, **104** may apply an electric field to the electronic ink **102**. The first electrode **103**, may be fabricated from either opaque and/or transparent materials. Suitable opaque electrode materials include, but are not limited to, solder paste, copper, copper-clad polyimide, graphite inks, silver inks and other metal-containing
25 conductive inks. Since the first electrode need not be transparent, the first electrode **103** can be constructed to display a selected color or an optical property complementary to that of the electronic ink **102**. The second electrode **104** may be fabricated from any transparent flexible material capable of conducting electricity such that electrodes **103**, **104** may apply an electric field to the electronic ink **102**. Suitable transparent electrode materials include, but are not
30 limited to, conductive polymers such as polyanilines or polythiopenes. The electrode materials may be made soluble so that electrodes **103**, **104** can be fabricated using coating techniques such as spin coating, spray coating, meniscus coating, printing techniques, forward and reverse roll

- 11 -

coating and the like. Alternatively, electrode materials may be applied from a vapor phase, by electrolytic reaction, or deposition from a dispersed state such as spray droplets or dispersions in liquids.

Referring again to FIG. 2A, the electronic ink **102** comprises an optoelectrically active component **120**, the “electrophoretic contrast media phase,” and a binder **130**, the “coating/binding phase,” which holds the optoelectrically active component **120** together. The optoelectronically active component **120** is an encapsulated electrophoretic material. Referring to FIG. 2B, the optoelectronically active component **120**, comprises one or more particles **122** in a suspending fluid **124**, both contained in capsules **125**. The particles **122** exhibit surface charges and may be either positively or negatively charged. The particles **122** may, for example, be colored, reflective, luminescent, light-absorbing or transparent. The particles **122** may be colored any one of a number of colors. The particles **122** in a given capsule may be of a single type, or two or more different types. The particles may, for example, include neat pigments, dyed (laked) pigments or pigment/polymer composites. The capsules **125** may be of any shape and of one or more shapes. The capsules may, for example, be spherical, ellipsoidal, cubic, rectangular parallelepipedal, pyramidal, or irregularly shaped. The capsules **125** may be formed by any suitable encapsulation technique. In one embodiment, a capsule **125** comprises a membrane that encapsulates the particles **122** and fluid **124**. In another embodiment, a capsule **125** comprises a void created in the binder **130** which encapsulates the particles **122** and fluid **124**. Such voids are also referred to as capsules herein even though no encapsulating membrane is present. The capsules **125** may have an average diameter in the range 5 to 500 microns. In a preferred embodiment, the average diameter of the capsules **125** is in the range 50 to 300 microns. In another preferred embodiment, the capsules’ average diameter is in the range of 75 to 300 microns. In a particularly preferred embodiment, the capsules **125** have an average diameter on the order of about 100 microns. Capsules this small allow significant bending of the display unit **100** without permanent deformation or rupture of the capsules themselves. The optical appearance of the electronic ink **102** itself is more or less unaffected by the curvature of the display unit **100**.

To provide a bistable display, the suspending fluid **124** has a specific gravity substantially matched to the density of the particles **122**. This provides a bistable display because the particles **122** do not tend to move within the capsule **125** absent an electric field applied via the electrodes **103**, **104**. As defined herein, a suspending fluid has a density that is “substantially matched” to

- 12 -

the density of the particle if the difference in their respective densities is between about zero and about two g/ml. This difference is preferably between about zero and about 0.5 g/ml. In a preferred embodiment, the suspending fluid **124** is dyed. In other embodiments, the fluid **124** is clear, or substantially clear, so that the fluid **124** does not inhibit viewing the particles **122** or the electrodes **103, 104** from viewpoint **101**. The suspending fluid **124** should have a low dielectric constant. A low dielectric constant allows an electric field to be established by electrodes **103, 104** across a capsule **125** with a minimum draw of power. In one embodiment, suspending fluid **124** comprises a single fluid. In other embodiments, the suspending fluid **124** comprises a blend of more than one fluid. Reactants or solvents for the microencapsulation process (oil soluble monomers, for example) can also be contained in the suspending fluid. Charge control agents can also be added to the suspending fluid. In one embodiment, the suspending fluid **124** contains surface modifiers to modify the surface energy or charge of the particles **122** or bounding capsule **125**. A preferred suspending fluid has a low dielectric constant (about 2), high volume resistivity (about 10^{15} ohm-cm), low viscosity (less than 5 cst), low toxicity and environmental impact, low water solubility (less than 10 ppm), high specific gravity (greater than 1.5), a high boiling point (greater than 90°C), and a low refractive index (less than 1.2).

The binder **130** can be selected from any suitable material. Binders are available in many forms and chemical types. Among these are water-soluble polymers, water-borne polymers, oil-soluble polymers, thermoset and thermoplastic polymers, and radiation-cured polymers. Suitable binder materials include, but are not limited to, polyurethanes, polyvinylalcohols, gelatins, polyacrylates, polystyrenes, polyvinylbutyrals, polyesters, epoxies, silicones, polycarbonates, their derivatives, and pressure-sensitive urethanes and adhesives.

Referring to FIG. 2C, in another embodiment, the capsules **125** contain two separate species of particles **128, 129** suspended in a clear suspending fluid, in which one species of particle absorbs light (black) **128**, while the other species of particle scatters light (white) **129**. In other embodiments, the capsules contain more than two species of particles, within either a clear or a dyed suspending fluid to produce multiple color or full color electrophoretic displays.

Referring to FIGS. 2D and 2E, the electrophoretic display unit **100** may further comprise a flexible substrate **127** onto which the first electrode **103** is disposed or into which it is incorporated. The electrophoretic display unit may further comprise a flexible transparent substrate **121** disposed on or incorporated with the second electrode **104**. Suitable substrate materials include, but are not limited to, plastics, fabrics, paper, or synthetic paper. In another

- 13 -

class of embodiments, an electrophoretic display unit is provided that comprises electronic ink disposed on a first electrode and an externally provided second electrode. Referring to FIGS. 2F – 2G, the electrophoretic display unit **100** comprises electronic ink **102** disposed on a first electrode **103**. In this class of embodiments, an externally provided second electrode **106**, such as, for example, an electrostatic print head or a charged stylus, applies voltage to the unit to change the display state of the display unit **100**. The electrophoretic display unit **100** may further comprise a flexible substrate **127** onto which the first electrode **103** is disposed or into which it is incorporated. Suitable substrate materials include, but are not limited to, plastics, fabrics, paper, or synthetic paper.

Referring to FIGS. 3A and 3B, the electronic ink **102** changes its display state, and as a result that of the display unit **100**, by electrophoresis. Specifically, application of different electric potentials to electrodes **103**, **104** establishes an electric field across capsule **125**. The electric field causes particles **122** to migrate towards the electrode of opposite charge, either **103** or **104**. There may be exactly one pair of electrodes **103**, **104** per capsule **125**, multiple pairs of electrodes **103**, **104** per capsule **125**, or a single pair of electrodes **103**, **104** may span multiple capsules **125**. Referring to FIG. 3A, if the particles **122** migrate towards the “top” electrode **104**, the display unit displays the optical property of the particles **122** to the viewpoint **101**. Conversely, referring to FIG. 3B, if the particles **122** migrate towards the “bottom” electrode **103**, the display unit displays the optical property of the fluid **124** to the viewpoint **101**.

There are many ways in which the display state change may be accomplished. In one embodiment, the suspending fluid **124** is dyed to provide a color contrast with the particles **122**. In one embodiment the suspending fluid **124** is white and the particles **122** black. In another embodiment, the suspending fluid **124** is black and the particles **122** white. Referring again to FIG. 3A, application of an electric field across the capsules **125** causes the particles **122** to move to the “top” of the capsule, FIG. 3A, thereby displaying the color of the particle **122** to the viewpoint **101**. According to the present invention, the particles **122** have a density matched to the specific gravity of the fluid **124** to produce a bistable display; and as a result, the particles **122** remain at the “top” of the capsule **125** after the electric field is withdrawn. Consequently, no power is required to maintain the display state. Thus, the only real current draw of the electronic ink display of the present invention is in changing the charge of the electrodes on either side of the electronic ink. Accordingly, the display state is changed by application of a different electric field across the capsules **125** that causes the particles **122** to move to the “bottom” of the capsule,

- 14 -

FIG. 3B, thereby displaying the color of the fluid 124 to viewpoint 101. In a preferred embodiment, at least one of the electrodes 103, 104 is configured to permit application of an electric field to select portions of the electronic ink 102, that is, the electrode configuration permits the electronic ink to be “addressed.” Suitable electrode configurations include, but are not limited to, matrix grid patterns, interleaved grid patterns, and mosaic font patterns. Alternatively, in another embodiment, the electrodes may be configured so that the particles migrate to the “side” of the capsule, i.e., a “shutter mode” configuration, and thereby display an optical property of the first electrode 103 to viewpoint 101 if the suspending fluid 124 is clear. The amount of time for which the electric field must be applied to move the particles to the “top,” “bottom,” or “side” of the capsule can be determined from the electrophoretic mobility of the particles, the strength of the applied electric field, and the size of the capsule.

In one embodiment, instead of using one electrophoretic display unit as an ESPL for each SKU, the present invention uses an electrophoretic display unit that comprises a single long strip comprising an electronic ink display that is capable of displaying messages at many points across its width. This permits the display to be hardwired to the shelf, yet the location of the information can be shown beneath the relevant product even when the product is physically moved. In a preferred embodiment, such a strip display would be able to show bar code, SKU and price data. Referring to FIG. 4A, one embodiment of a device for the electronic display of information on a storage surface comprising a strip display is illustrated. In a preferred embodiment, the storage surface 1 comprises a shelf 2 for supporting goods 3 and an extension 4 with a strip display 35 disposed thereon. As illustrated, in a preferred embodiment the extension 4 comprises the standard channel groove provided on a standard gondola-type shelf 2. In one embodiment, the strip display 35 is disposed on the extension 4 by flexing the display unit so that the upper and lower edges 6 and 7 of the display unit fit into the recesses 8 and 9 of the extension channel. In another embodiment, the strip display 35 is disposed on the extension 4 by sliding the strip display into the channel groove from the end of the groove. In a preferred embodiment, the strip display comprises an electrophoretic display unit capable of displaying more than one message 37 along its length and comprising at least two segments 38 in electrical communication with each other and with independently updateable electronic ink display segments 32.

In another embodiment, the strip display further comprises a permanent label capable of transmitting its location to a control mechanism that in turn updates the product information or price on the portion of the strip display directly adjacent to the permanent label. In this

- 15 -

embodiment, the store employee can move a product and, simply by moving the permanent label, cause the price to be updated to the correct shelf. In one embodiment, the permanent label is embedded with a unique serial code.

In another embodiment, an alternate or adjunct to an ESPL system of electrophoretic display units that offers yet another retail application of electronic ink is a storage surface
5 “highlighting” display strip. According to the present invention, and referring to FIG. 4B, a “highlighting” display strip **45** is capable of displaying only a small number of “pixels,” i.e., display elements **48**. For example, on one embodiment, the “highlighting” display strip **45** is 3 feet wide and ¼” tall, the strip is split into display elements **48** that are each 3 inches wide; and
10 thus, the strip in this embodiment contains just 12 display elements. This greatly reduces cost. Each display element **48** of the “highlighting” display strip comprises an electronic ink display with an “on” display state and an “off” display state. Such display states include, for example, effects such as solid colors **49** or color patterns **50**. In addition, a “highlighting” display strip display element may be cyclically switched “on” and “off” and create a blinking effect.
15 Referring again to FIG. 4B, in one embodiment, a “highlighting” display strip **45** runs along the edge **44** of product-holding display **1**, and may be proportioned to fit easily into a gondola-type or other retail fixture. In one embodiment, the “highlighting” display strip **45** comprises a multiple display elements **48**. By activating display elements beneath certain shelf portions, the retailer may communicate product information. For example, all sale items may be highlighted
20 by display elements displaying a red color underneath them. This information may be driven from a data source so that, for example, the overall length of the activated display elements corresponds to the correct width of the product facing according to “plan-o-gram” data of the store. In this manner, during shopping hours the retailer may highlight sales and specials. During restocking hours the owner may highlight products that must be restocked or
25 repositioned.

In another embodiment, the device for the electronic display of information on a storage surface comprising an electrophoretic display unit of the present invention further comprises an information updating unit that communicates an electrical signal to an electrophoretic display unit, or group of electrophoretic display units, to change the message displayed. Referring to
30 FIGS. 5A to 5C, in a preferred embodiment, the storage surface **201** comprises a shelf **202** for supporting goods **203** and an extension **204** with at least one electrophoretic display unit **205** disposed thereon and an information updating unit **207, 217, 227, 237, 247** in electrical

- 16 -

communication **221, 222** with at least one electrophoretic display unit. In some embodiments, as illustrated in FIGS. 5A and 5C, the information updating unit **207, 217, 227, 247** is disposed adjacent the storage surface **201**. In another embodiment, the information updating unit and electrophoretic display unit are integrated on a common substrate. In other embodiments, as
5 illustrated in FIG. 5B, the information updating unit **237** is external to and detached from the storage surface **201**. The information updating unit may be in electrical communication **221, 222** with a single electrophoretic display unit **205** or a plurality of electrophoretic display units. The information updating unit may be in electrical communication with an electrophoretic display unit **205** via hardwires **221**, inductive transmission **222**, piezoelectric transmission, photovoltaic
10 transmission, or any other suitable means of electrical communication. The primary function of the information updating unit is to change the display state, or message, of the electrophoretic display unit **205** or units in response to an update signal. In response to the update signal, the information updating unit communicates an electrical signal to either, a first electrode, a second electrode, or both, of the electrophoretic display unit **205** or units to change the display state.

15 The term “update signal” is meant to include any information that can be utilized by the information updating unit including, but not limited to, analog signals and digital signals. The update signal can comprise codes describing how the electrophoretic display unit should display or transition between messages, or any other suitable information that will cause the electrophoretic display unit **205** or units to operate as desired by the retailer. Accordingly, the
20 update signal can also include a header, error-checking, checksum, routing or other information that facilitates the function of the information updating unit and/or electrophoretic display unit. In one embodiment, the update signal is an RF signal that provides electric energy via induction to power the display state change of the electrophoretic display unit. The update signal can comprise, for example, an electrical signal, a RF or radio-wave signal, an infrared signal, or even
25 an audio signal. Accordingly, the update signal can be communicated by wire or wireless communication.

The update signal is usually transmitted together with the specific address code for the respective electrophoretic display unit **205** or the respective group of display units, as well as price and/or product information for the goods in question. In this manner, it is possible to
30 modify the indicated prices, such as for a special sale with reduced prices, with little expense or effort. The information updating unit may receive an update signal by any suitable means including, but not limited to, wire transmission, wireless transmission, surface contact pad on the

- 17 -

surface, IR port, optical sensor, audio sensor, or induction loop. In one embodiment, the update signal may be provided by a central control mechanism, such as, for example, a local store computer, a regional computer, or a national computer. In other embodiments, as illustrated in FIG. 5A, the information updating unit comprises a sensor **207, 217, 227** and the update signal is a response to an environmental condition detected by the information updating unit (as sensor) **207, 217, 227** disposed adjacent the storage surface **201**. In one embodiment, the sensor is an audio sensor **207**. In another embodiment, the sensor is an optical or IR sensor **227**. In another embodiment, the sensor is a pressure sensor **217**. However it is to be understood that the information updating unit may comprise any sensor suitable to the retail environment. Suitable sensors include, but are not limited to, audio, optical, pressure, motion and IR sensors. In preferred embodiments, the power for the generation of a sensor signal generated in response to an environmental condition comes from the environmental condition itself. For example, for a pressure sensor, power could be generated by the piezoelectric effect or triboelectric effect, while for an optical sensor, power could be generated by the photovoltaic effect. In another embodiment, the information updating unit comprising a sensor further comprises a logic circuit that updates the information displayed by the electrophoretic display unit based on and in response to the environmental condition. In this embodiment, it is preferred that the logic circuit contain suitable embedded software. Examples of suitable embedded software are discussed below.

In one embodiment, the information updating unit comprises a logic circuit that updates the information displayed by the electrophoretic display unit based on and in response to the update signal. In one preferred embodiment, the information updating unit comprising a logic circuit is integrated with the electrophoretic display unit on a common substrate. In a preferred embodiment, the logic circuit contains embedded software which facilitates updating the electrophoretic display unit. In one embodiment, the embedded software includes an event scheduler. In a preferred embodiment, the event scheduler is tied in to a system clock that is used to determine when to activate the information updating unit and update the associated electrophoretic display unit or units. In another embodiment, the embedded software comprises a communications module which activates the information updating unit, receives the update signal data, determines whether the update signal received is relevant to the electrophoretic display unit, and if so, updates the display state of the electrophoretic display unit. In another embodiment, the embedded software further monitors the update signal data received and

- 18 -

attempts to handle any errors that may be detected in download. In another embodiment, the embedded software includes a script interpreter. The script interpreter accesses specific data stored in embedded software memory and analyzes the update signal data content to cause changes and updates to the associated electrophoretic display unit or units. The script interpreter therefore, in one embodiment, controls the display of prices, text, images and graphics, as well as effects such as fades, wipes, wiggling, blinking, flashing, and so forth. In still another embodiment, if a script contains a reference to time then the interpreter will fill in the appropriate value from a system clock.

Referring to FIG. 5B, in one embodiment the information updating unit **237** comprises a second electrode **236**. In one embodiment, the second electrode **236** of the information updating unit comprises an electrostatic print head; in another, it comprises a charged stylus. The electrostatic print head permits very high resolution addressing of the electronic ink of the electrophoretic display unit. In one embodiment of the present invention, the electronic ink of the electrophoretic display unit is electrostatically writable. This electrostatically writable electrophoretic display unit may be incorporated with a non-electrostatically writable electrophoretic display unit, such as in a display strip, such that portions of the overall display can be updated by the electrostatic print head whereas other portions will be unaffected. In one embodiment, the display of the electrostatically writable electrophoretic display unit may be updated, i.e., rewritten, by a handheld information updating unit comprising an electrostatic print head. In another embodiment, electrical charge is built up on the surface of the electronic ink for changing the display state thereof through frictional or triboelectric charging; in another embodiment, by using a sheet of piezoelectric material.

Referring to FIG. 5C, in another embodiment, the device for the electronic display of information on a storage surface comprising an electrostatically writable electrophoretic display unit **205** of the present invention further comprises a track **241** disposed along the extension **204** and an information updating unit **247** comprising an electrostatic print head is slidably disposed on the track **241** such that the information updating unit **247** can come into electrical communication with an electrophoretic display unit **205** and update the display thereof. In this embodiment, the information updating unit **247**, in response to an update signal, moves along the track **241** until it comes into electrical communication with the appropriate electrophoretic display unit. The information updating unit **235** then electrostatically changes the display state of, i.e., rewrites, the electrophoretic display unit and thereby updates the display.

- 19 -

Another object of the invention is to provide a store wide product information and price display system. The primary function of the store wide product information and price display system (hereinafter “store wide product system”) is to ensure that updates in product information and price are both consistent throughout the store and are rapidly posted with a minimum of manual labor. Referring to FIG. 6, in one embodiment, the store wide product system **2000** comprises electrophoretic display units **2050**, information updating units **2070**, and a control system **2100** which enables a retailer to create and transmit update signals to the information updating units **2070** and thereby change the display state of select electrophoretic display units **2050** throughout the store. An information updating unit may be in electrical communication with a single electrophoretic display unit **2050** or a group of electrophoretic display units **2055**. As discussed above, the information updating unit may comprise, for example, an IR sensor, an audio sensor, a radio-frequency antenna, or any device that is able to receive the update signal **2999**. In one preferred embodiment, the information updating unit comprises an RF antenna and receives the update signal via induction. The information updating unit may further comprise a suitable transmitter that is able to communicate with the control system. In one embodiment, this transmitter enables the information updating unit to communicate information obtained from information updating units that comprise a sensor **2072**. In one embodiment, for example, an information updating unit comprising a shelf pressure sensor may communicate **2900** to the control system **2100** when a shelf is empty, or almost empty, of particular goods and thereby “flag” such goods for restocking or reorder. The information updating units may act as members of a wired or wireless daisy chain of update signal transceivers. The information updating units **2070** and electrophoretic display units **2050** may be powered by any suitable means including AC outlet, DC converter, induction loop, capacitive coupling, battery, or solar cell. In preferred embodiments, the information updating units and electrophoretic display units are powered by induction, battery, and/or solar cell.

In another embodiment, the store wide product system **2000** further comprises electronic signage **2080** which may comprise electronic ink signage or other electronic signage updateable by control system **2100**. In certain embodiments, an information updating unit and at least one electrophoretic display unit together comprise an integrated display unit **2060**. In still another embodiment, an integrated display unit, an electrophoretic display unit or electronic ink signage may be incorporated into employee clothing **2090**, such as a jacket, and thereby provide a mobile display that nevertheless can be almost instantly updated with information that is consistent

- 20 -

throughout the store. In a preferred embodiment, the control system **2100** of the store wide product system **2000** is integrated into the POS data system **2200**, or comprises the POS data system. In this embodiment the retailer can, from a centrally located control center **2105**, update product information and price while ensuring that the price the consumer has been lead to believe
5 a product cost from the labels and signage at the POD **2001**, will match the price registered at the POS **2201**.

In one embodiment, wireless radio-wave communication devices and methods are used to communicate the update signal **2999** to the information updating units **2070**. In one embodiment, each information updating unit **2070** is outfitted with a short range wireless
10 transceiver and update signals are transmitted from information updating unit to information updating unit in a daisy chain manner. In another embodiment, each information updating unit has a short-range radio antenna capable of receiving only nearby update signals, for example, signals from a distance of no more than 6-12 inches. Referring again to FIG. 6, small, inexpensive transmitters **2155** are installed near the storage surface **2300**. In this embodiment, a
15 control system **2100** communicates a signal to the transmitters **2155** which in turn transmit an update signal **2999** to the nearby information updating unit **2070**. The short receiving ranges permit only a few information updating units to receive a given signal from a given transmitter and thereby reduce the addressing complexity that must be handled by an information updating unit itself. Further, the transmission of RF data over short distances is sufficient not only to
20 power simple logic circuitry by induction but is also sufficient to power by induction the change of the display state of an electrophoretic display unit **2050**. After the RF signal fades, the electrophoretic display unit **2050** of the present invention has been set to a new message and holds this message without power consumption until updated again.

In another embodiment, update signals are communicated by audio transmission. In this
25 embodiment, the information updating unit **2070** comprises a sound wave-sensing device, such as a microphone, and a logic circuit. Appropriate embedded software of the logic circuit analyzes the sound using, for example, techniques used in acoustic coupling modems, noise cancellation, automatic gain control, speech verification, speaker identification, and/or speech recognition, to determine whether an instruction to update the display of an electrophoretic
30 display unit or units has been received. This embodiment offers several advantages: (1) extreme low cost and low power draw; (2) it is unaffected by direct sunlight levels unlike infrared signal transmission; and (3) it is immune to and does not create RF interference. In one embodiment, a

- 21 -

loudspeaker **2140** transmits update signals as sound waves **2144**, preferably at a frequency outside of the range of human hearing, across the store or a region of the store. Loudspeakers could be located either in fixed locations and/or on mobile locations such as a special cart that is rolled up and down the aisles periodically. In another embodiment, a customer or store employee

5 **2145** simply speaks a command phrase and the logic circuit analyzes the sound and the information updating unit changes the display state of the electrophoretic display unit accordingly. For example, command phrases such as, "COST," "PEANUTS," and "CALORIES," could be used to cause the electrophoretic display unit to display, respectively, information about product cost, whether a food product contains peanuts or peanut oil, and the

10 number of calories of a food product.

In another embodiment, a store employee and/or customer employs a handheld information updating unit **2075**, such as a smartcard with transceiver or a store-supplied handheld shopping device that may be customized to the shopper, to update the display state of an electrophoretic display unit. For example, when a customer brings the handheld information

15 updating unit **2075** into electrical communication with an electrophoretic display unit **2050**, perhaps by touching the handheld information updating unit to the electrophoretic display unit or by induction, alternative information is posted for the customer. For example, the customer may wish to know whether a food product meets vegetarian requirements or contains substances, such as peanut oil, that can cause fatal allergic reactions in many individuals or specific customer. Or

20 the customer may enter an order for a product associated with the electrophoretic display unit and wish to see visual confirmation by a change in the electrophoretic display unit display state. Or, the shopper may offer to buy the product at an alternate price and a logic circuit integrated with the electrophoretic display unit or the handheld information updating unit decides to "accept" or "reject" the offer. In addition, the logic circuit may use information from sensors associated with

25 the ESPL system, such as shelf mounted pressure sensors that indicate the amount of product on display, to decide whether to "accept" or "reject" an alternate price offer.

In one embodiment, the control system **2100** features a user interface that permits the retailer to transmit update signals to update product information and price at the POD **2001**. In another embodiment, the control system **2100** functions as a inventory tracking and accounting

30 system that monitors product supply, places and/or verifies product orders, keeps account of product sales, and/or creates reports correlating changes in POD **2001** information and price with POS sells. The control system **2100** may also utilize multiple authority levels allowing different

- 22 -

parties to variously update product price and product information for select products or for all products store wide; all from the same control system **2100**.

The flexible, electronic ink display described above is useful in numerous retail applications where paper is currently the display medium of choice. The displays can be rolled
5 or bent. In other embodiments, the displays can be placed onto or incorporated into highly flexible plastic substrates, fabric, paper, or synthetic paper. Since the displays can be rolled and bent without sustaining damage, they form large-area displays which are highly portable. Since these displays can be printed on plastics they can be lightweight. In addition, the printable,
10 electronic ink display of the present invention can maintain the other desirable features of electrophoretic displays, including high reflectance, bistability, and low power consumption. Electrophoretic display media are described in more detail in co-pending United States Patent Applications Serial Nos. 08/819,320, 08/935,800, 09/140,792, 09/140,862 and 09/289,507, the contents of which are incorporated herein by reference.

In combining the embodiments above, it can be seen that electronic ink offers a way for
15 retailers to dramatically change the store environment so that the store may become more interactive and individualized, yet at the same time, achieve higher standards of compliance with less labor cost and faster turnaround times.

While the invention has been particularly shown and described with reference to specific
20 embodiments, it should be understood by those skilled in the art that various changes in form and detail may be made therein without departing from the spirit and scope of the invention as defined by the appended claims

- 23 -

CLAIMS

- 1 1. A device for the electronic display of information on a storage surface comprising:
2 (a) a goods storage surface, wherein said goods storage surface comprises:
3 (i) a portion for supporting goods; and
4 (ii) an extension for displaying information;
5 and
6 (b) an updatable electrophoretic display unit proximately disposed on said extension,
7 wherein said electrophoretic display unit comprises:
8 (i) a bistable encapsulated electrophoretic display medium, and
9 (ii) a first electrode disposed adjacent said electrophoretic display medium,
10 wherein said display state changes in response to an electrical signal communicated to
11 said first electrode.
- 1 2. The device of claim 1 wherein said goods storage surface comprises a shelf.
- 1 3. The device of claim 1 wherein said extension comprises a shelf edge molding.
- 1 4. The device of claim 1 wherein said updatable electrophoretic display unit comprises a
2 flexible bistable encapsulated electrophoretic display medium.
- 1 5. The device of claim 1 wherein said updatable electrophoretic display unit comprises a
2 strip having a plurality of bistable encapsulated electrophoretic display media in electrical
3 communication with each other.
- 1 6. The device of claim 1 wherein said bistable encapsulated electrophoretic display medium
2 is a bistable encapsulated color electrophoretic display medium.
- 1 7. The device of claim 1 wherein said bistable encapsulated electrophoretic display medium
2 forms a multiple seven-segment display.
- 1 8. The device of claim 1 further comprising an information updating unit for communicating
2 the electrical signal to said first electrode.
- 1 9. The device of claim 8 wherein said information updating unit comprises a sensor in
2 communication with the first electrode.
- 1 10. The device of claim 9 wherein said sensor comprises an optical sensor.
- 1 11. The device of claim 9 wherein said sensor comprises a microphone.
- 1 12. The device of claim 9 wherein said information updating unit further comprises a logic
2 circuit in communication with said sensor wherein said logic circuit communicates an electrical
3 signal to the first electrode in response to data received from said sensor.

- 24 -

1 13. The device of claim 8 wherein said information updating unit comprises a short-range
2 radio antenna in communication with the first electrode.

1 14. The device of claim 8 wherein said information updating unit comprises an electrostatic
2 printing device.

1 15. The device of claim 14 wherein the extension further comprises a track disposed along
2 the extension and said electrostatic printing device is movable along said track.

1 16. The device of claim 8 further comprising an information transmittal unit for
2 communicating an update signal to the information updating unit, wherein said information
3 updating unit in response to the update signal communicates the electrical signal to said first
4 electrode to update said electrophoretic display unit.

1 17. The device of claim 16 wherein the update signal provides the power necessary to
2 generate the electrical signal communicated to the first electrode to update the electrophoretic
3 display unit.

1 18. A device for the electronic display of information on a storage surface comprising:

- 2 (a) a shelf for supporting goods;
3 (b) an extension for displaying information disposed adjacent said shelf; and
4 (c) at least one updatable electronic shelf label having an updatable display state
5 disposed adjacent said extension, wherein each said electronic shelf label comprises a
6 bistable encapsulated electrophoretic display medium.

1 19. The device of claim 18 wherein said bistable electrophoretic display medium comprises a
2 flexible bistable encapsulated electrophoretic display medium.

1 20. The device of claim 18 further comprising a substrate disposed adjacent the extension;
2 wherein said substrate comprises a plurality of segments in electrical communication with each
3 other and wherein at least one said updatable electronic shelf label is proximately disposed on at
4 least one of said segments.

1 21. The device of claim 20 further comprising:

- 2 (a) a label feedback unit in communication with said at least one updatable electronic
3 shelf label, wherein said label feedback unit generates a signal in response to a environmental
4 condition proximate to a storage surface; and
5 (b) a control mechanism in communication with said label feedback unit and said
6 substrate, wherein said control mechanism in response to said signal from said label feedback

- 25 -

7 unit generates a control signal that changes the display state of said updatable electronic shelf
8 label.

1 22. The device of claim 21 wherein the environmental condition comprises the location of a
2 good disposed on said shelf for supporting goods.

1 23. The device of claim 21 wherein the environmental condition comprises the occurrence of
2 a soundwave.

Attorney's Docket No. INK-075PC

CA 02373142 2001-10-30

- 25a -

24. A device for the electronic display of information on a storage surface comprising:
- (a) a goods storage surface, wherein said goods storage surface comprises:
 - (i) a portion for supporting goods; and
 - (ii) an extension for displaying information;
 - (b) an updatable electrophoretic display unit proximately disposed on said extension, wherein said electrophoretic display unit comprises:
 - (i) a bistable encapsulated electrophoretic display medium, and
 - (ii) a first electrode disposed adjacent said electrophoretic display medium, wherein said display state changes in response to an electrical signal communicated to said first electrode; and
 - (c) an information updating unit comprising an electrostatic print head for communicating the electrical signal to said first electrode.
25. The device of claim 24 wherein said goods storage surface comprises a shelf.
28. The device of claim 24 wherein said extension comprises a shelf edge molding.
29. The device of claim 24 wherein the extension further comprises a track disposed along the extension and said electrostatic printing device is movable along said track.
28. The device of claim 24 wherein said updatable electrophoretic display unit comprises a flexible bistable encapsulated electrophoretic display medium.
29. The device of claim 24 wherein said updatable electrophoretic display unit comprises a strip having a plurality of bistable encapsulated electrophoretic display media in electrical communication with each other.
30. The device of claim 24 wherein said bistable encapsulated electrophoretic display medium is a bistable encapsulated color electrophoretic display medium.
31. The device of claim 24 wherein said bistable encapsulated electrophoretic display medium forms a multiple seven-segment display.
32. The device of claim 24 wherein said information updating unit further comprises a sensor in communication with the first electrode.
35. The device of claim 32 wherein said sensor comprises an optical sensor.
36. The device of claim 32 wherein said sensor comprises a microphone.

AMENDED SHEET

35. The device of claim 32 wherein said sensor comprises an optical sensor.
36. The device of claim 32 wherein said sensor comprises a microphone.
35. The device of claim 32 wherein said information updating unit further comprises a logic circuit in communication with said sensor wherein said logic circuit communicates an electrical signal to the first electrode in response to data received from said sensor.
36. The device of claim 24 wherein said information updating unit further comprises a short-range radio antenna in communication with the first electrode.
37. The device of claim 24 further comprising an information transmittal unit for communicating an update signal to the information updating unit, wherein said information updating unit in response to the update signal communicates the electrical signal to said first electrode to update said electrophoretic display unit.
39. The device of claim 37 wherein the update signal provides the power necessary to generate the electrical signal communicated to the first electrode to update the electrophoretic display unit.
39. A device for the electronic display of information on a storage surface comprising:
- (a) a shelf for supporting goods;
 - (b) an extension for displaying information disposed adjacent said shelf;
 - (d) at least one updatable electronic shelf label having an updatable display state disposed adjacent said extension, wherein each said electronic shelf label comprises a bistable encapsulated electrophoretic display medium; and
 - (d) a substrate disposed adjacent the extension; wherein said substrate comprises a plurality of segments in electrical communication with each other and wherein at least one said updatable electronic shelf label is proximately disposed on at least one of said segments.
40. The device of claim 39 wherein said bistable electrophoretic display medium comprises a flexible bistable encapsulated electrophoretic display medium.
42. The device of claim 39 further comprising:
- (a) a label feedback unit in communication with said at least one updatable electronic shelf label, wherein said label feedback unit generates a signal in response to a environmental condition proximate to a storage surface; and

(b) a control mechanism in communication with said label feedback unit and said substrate, wherein said control mechanism in response to said signal from said label feedback unit generates a control signal that changes the display state of said updatable electronic shelf label.

42. The device of claim 39 wherein the environmental condition comprises the location of a good disposed on said shelf for supporting goods.

43. The device of claim 39 wherein the environmental condition comprises the occurrence of a soundwave.

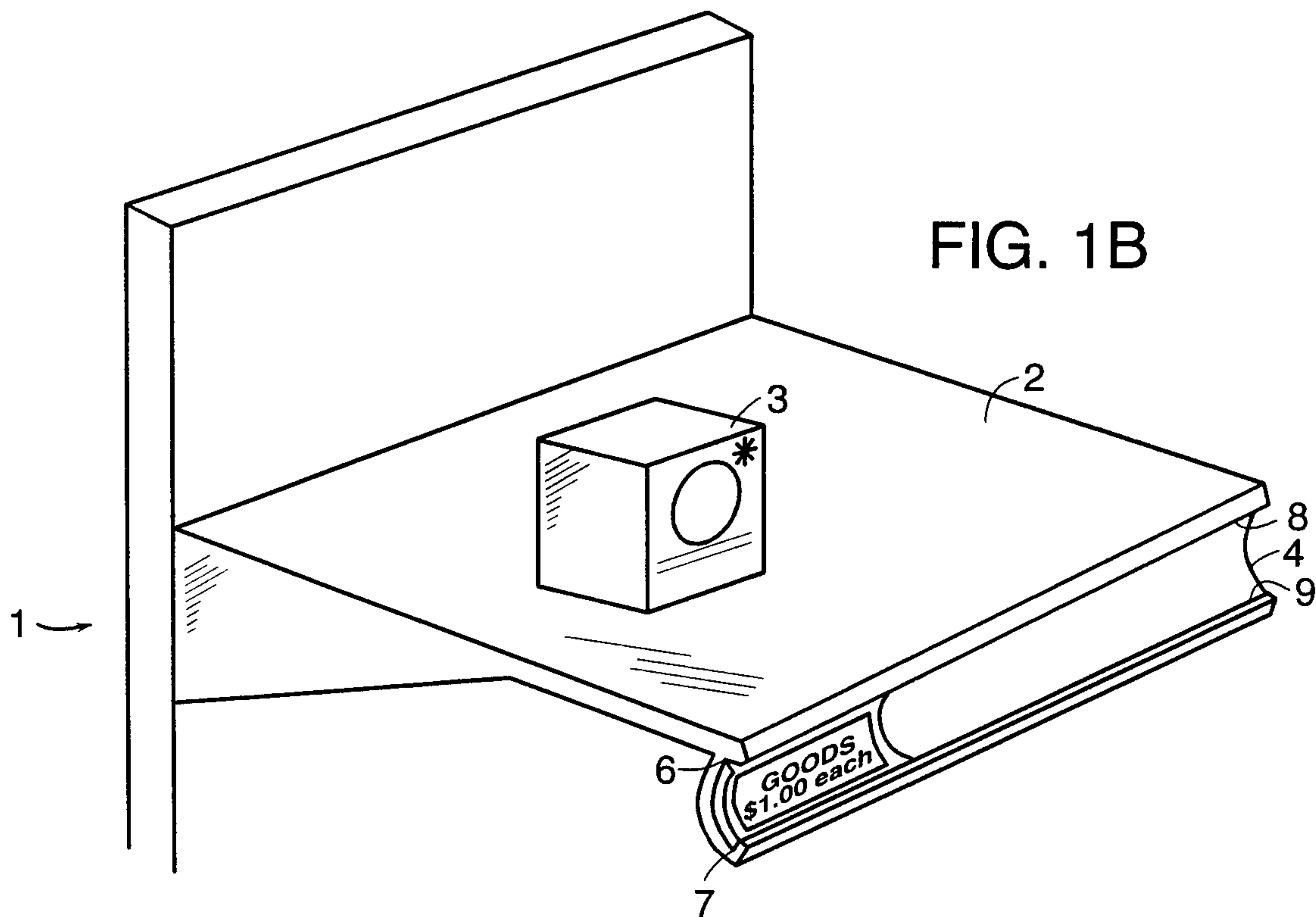
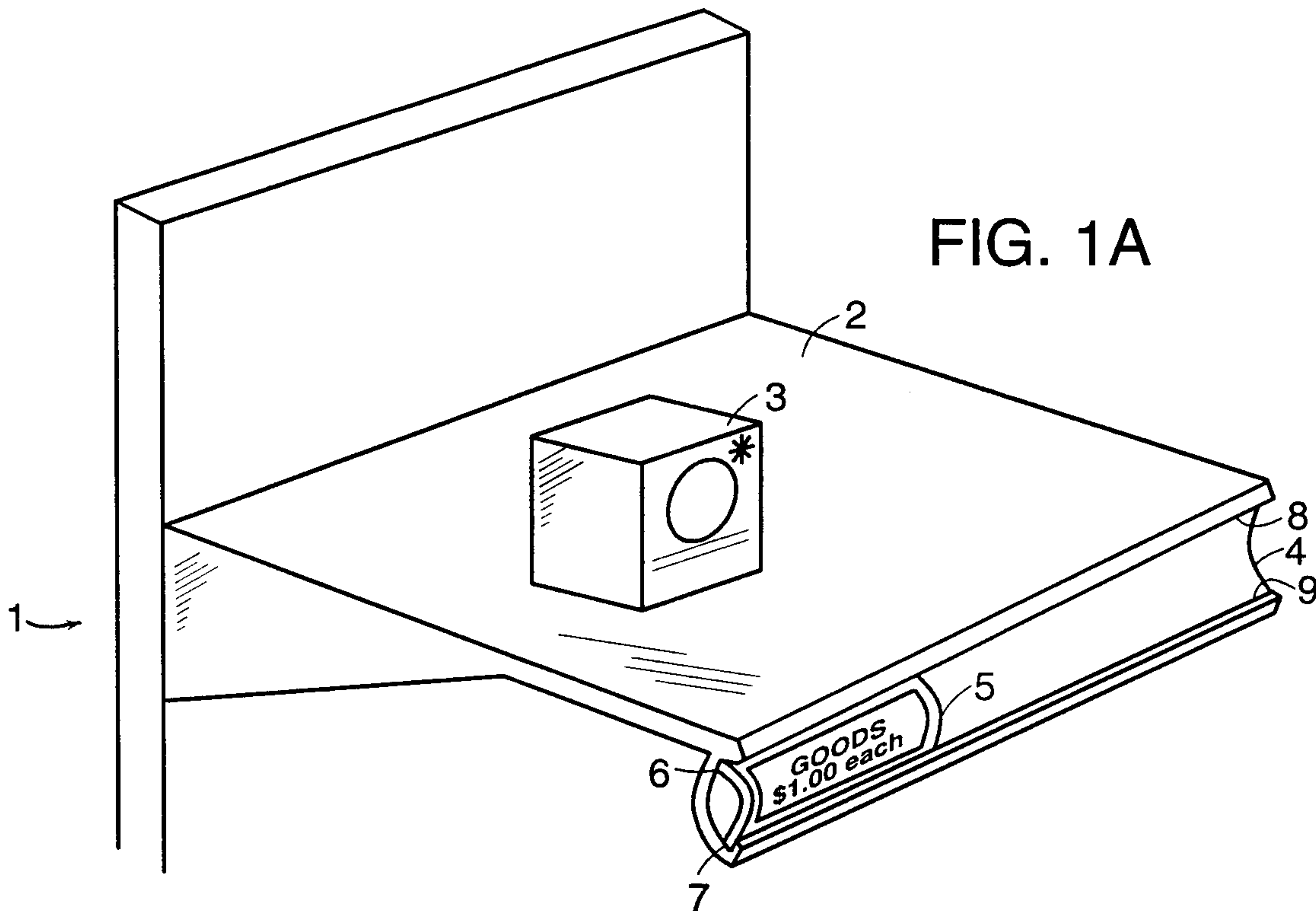

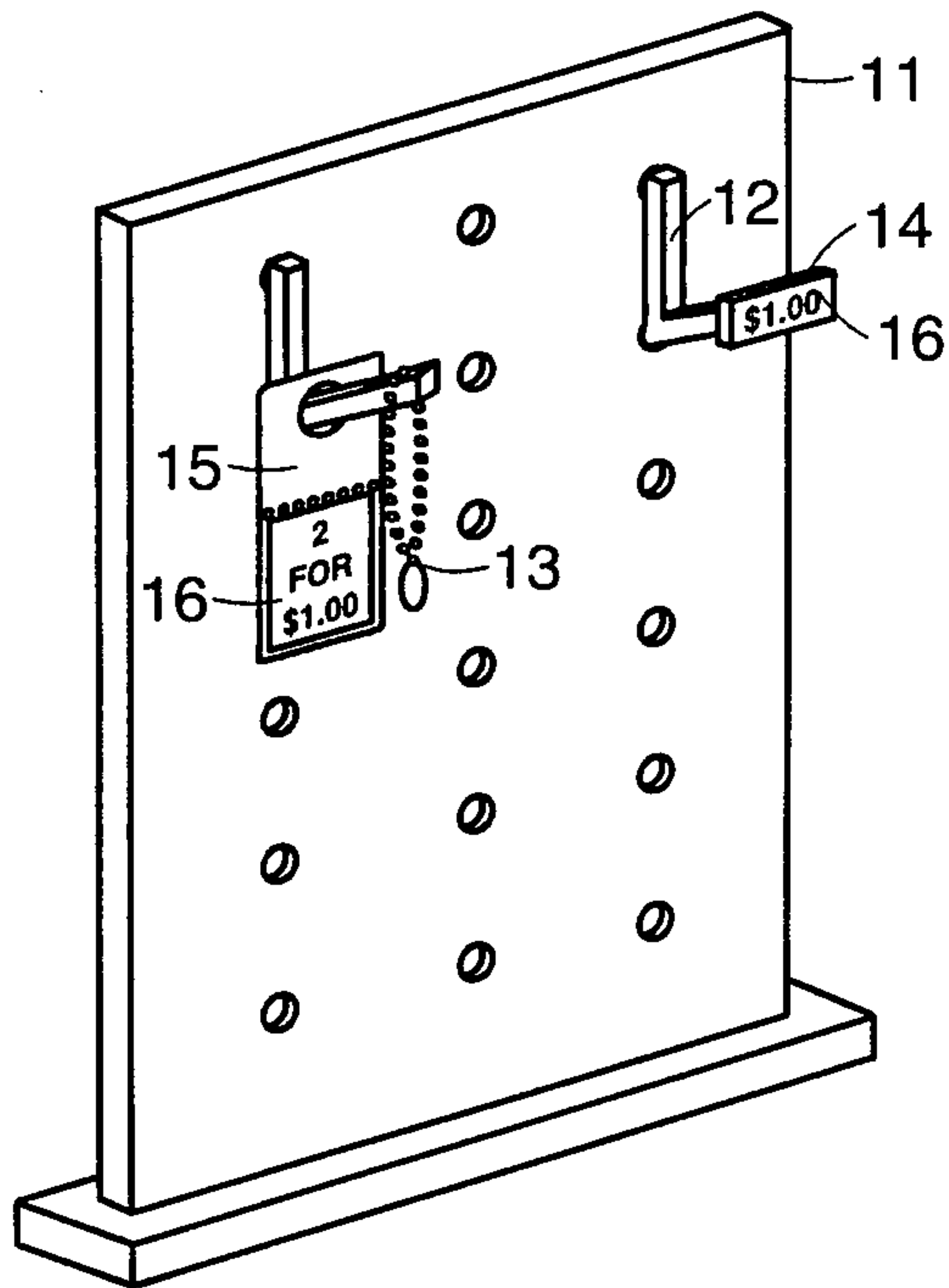

FIG. 1C

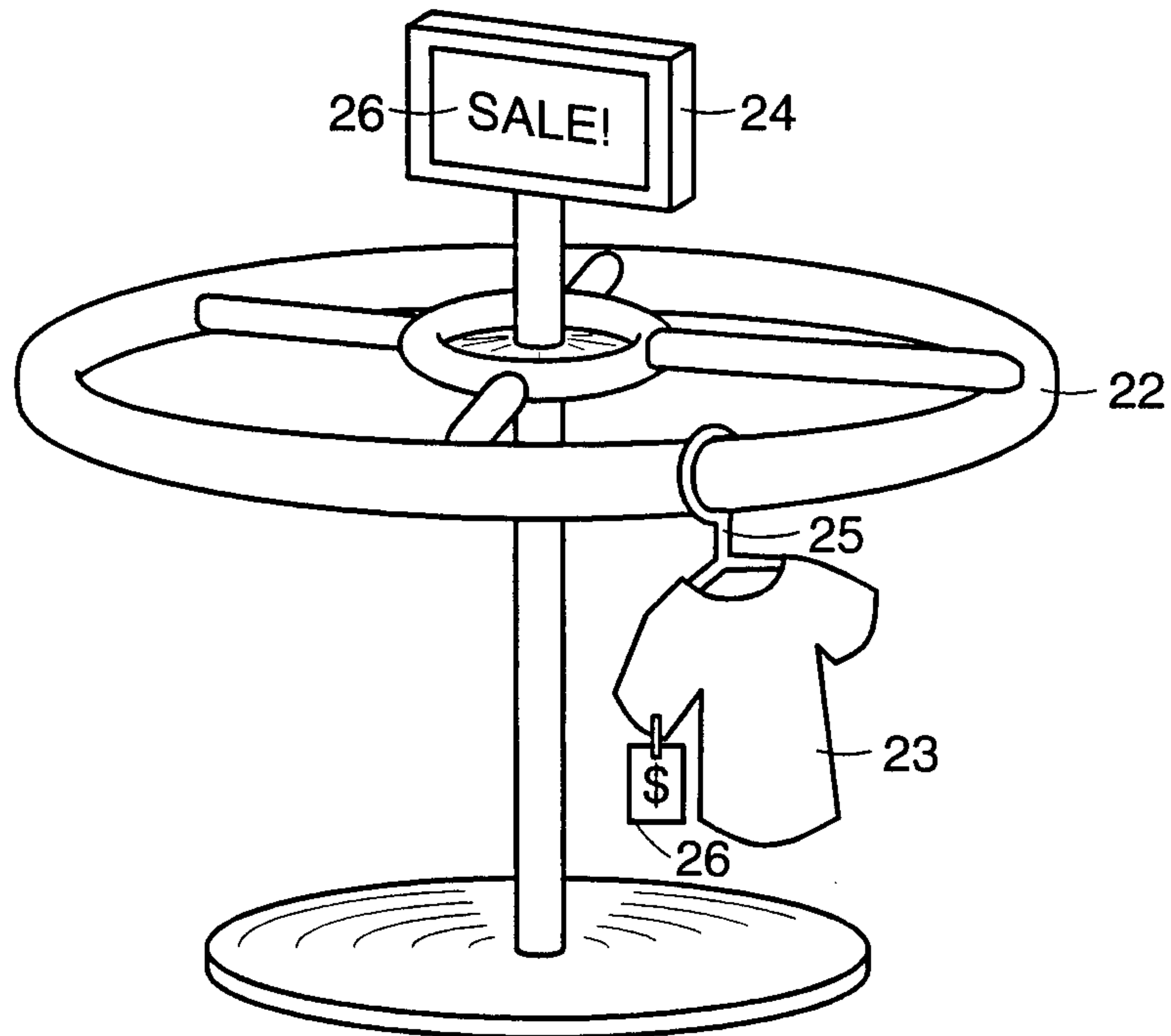

FIG. 1D

3/11

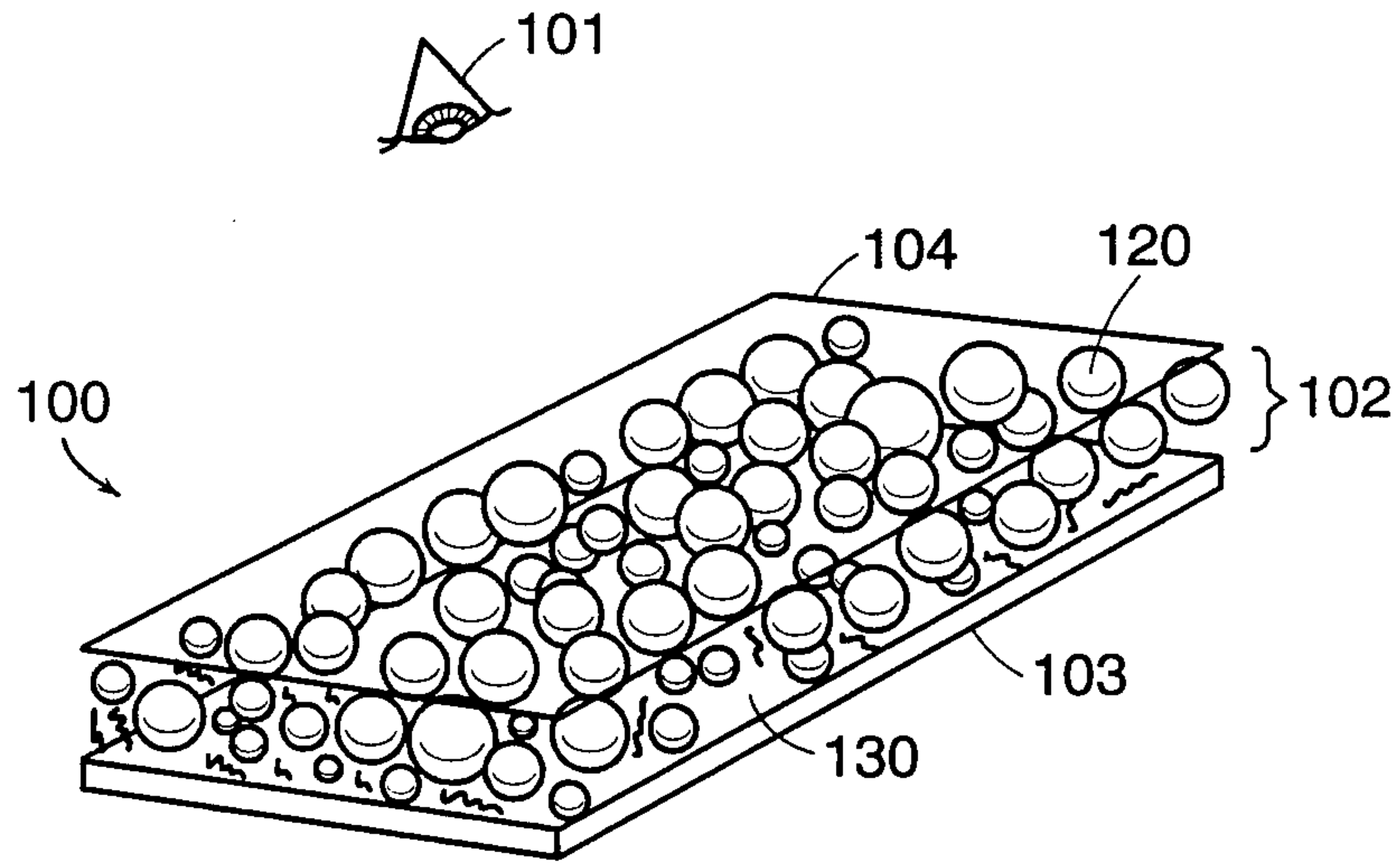

FIG. 2A

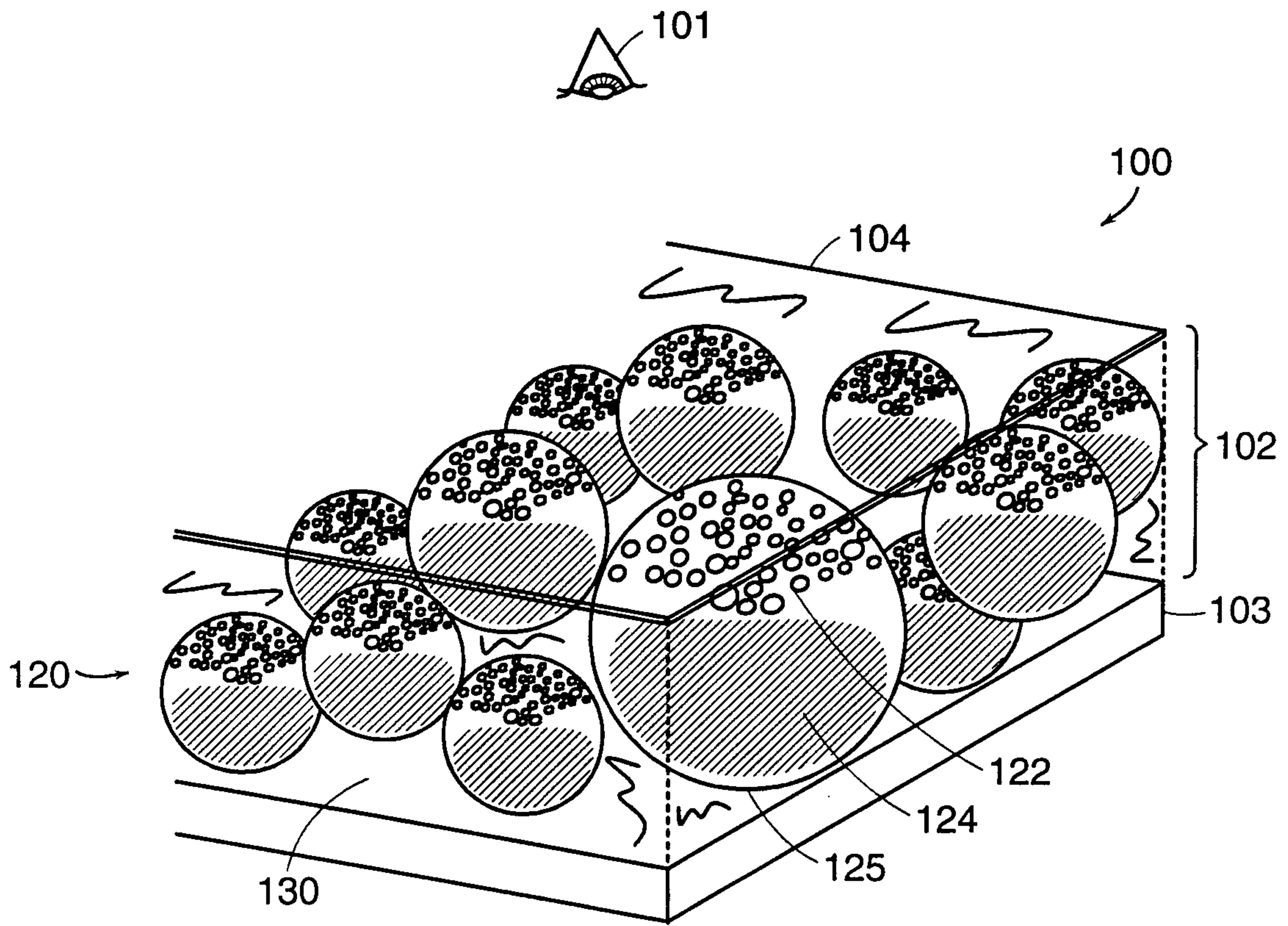

FIG. 2B

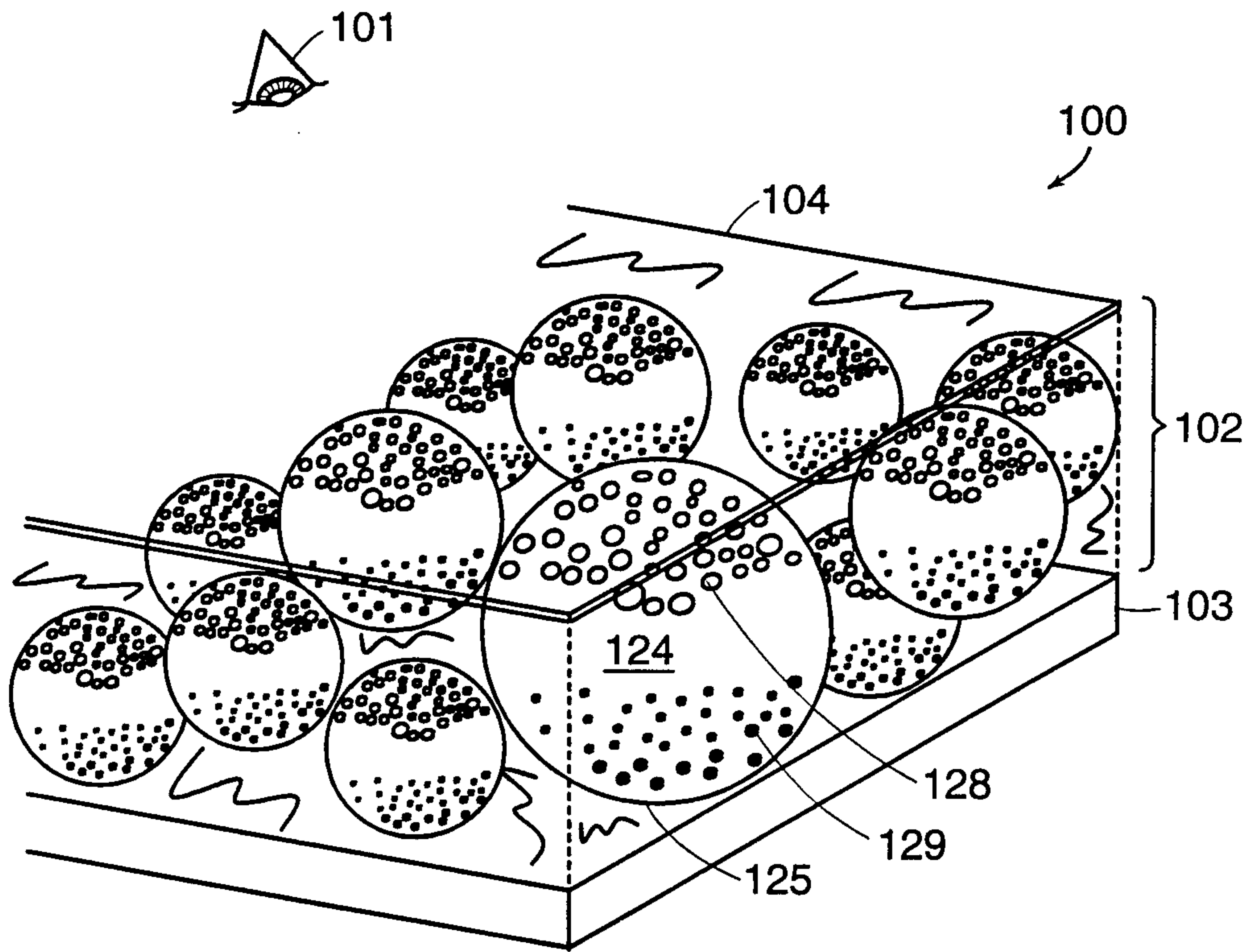

FIG. 2C

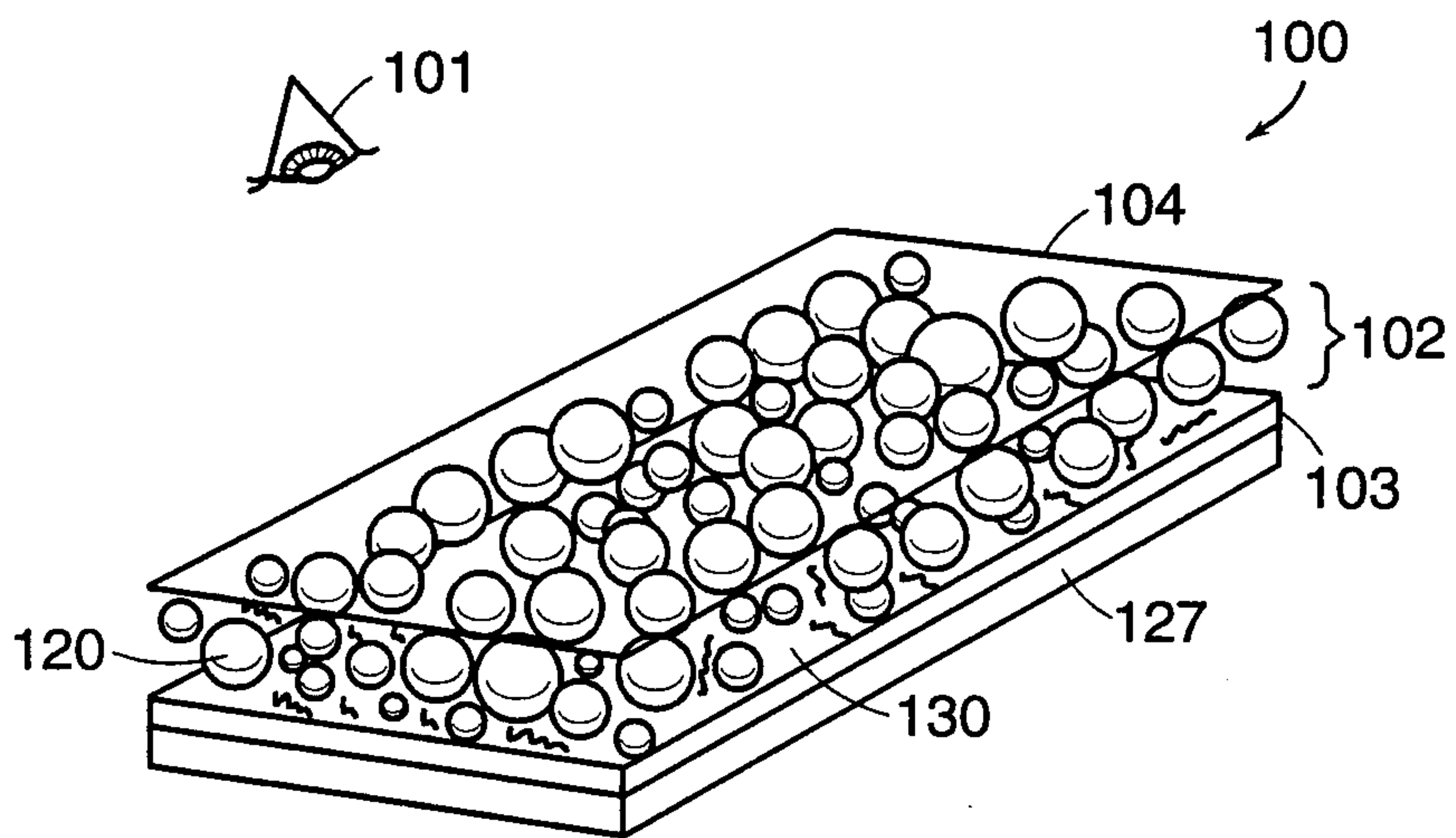

FIG. 2D

5/11

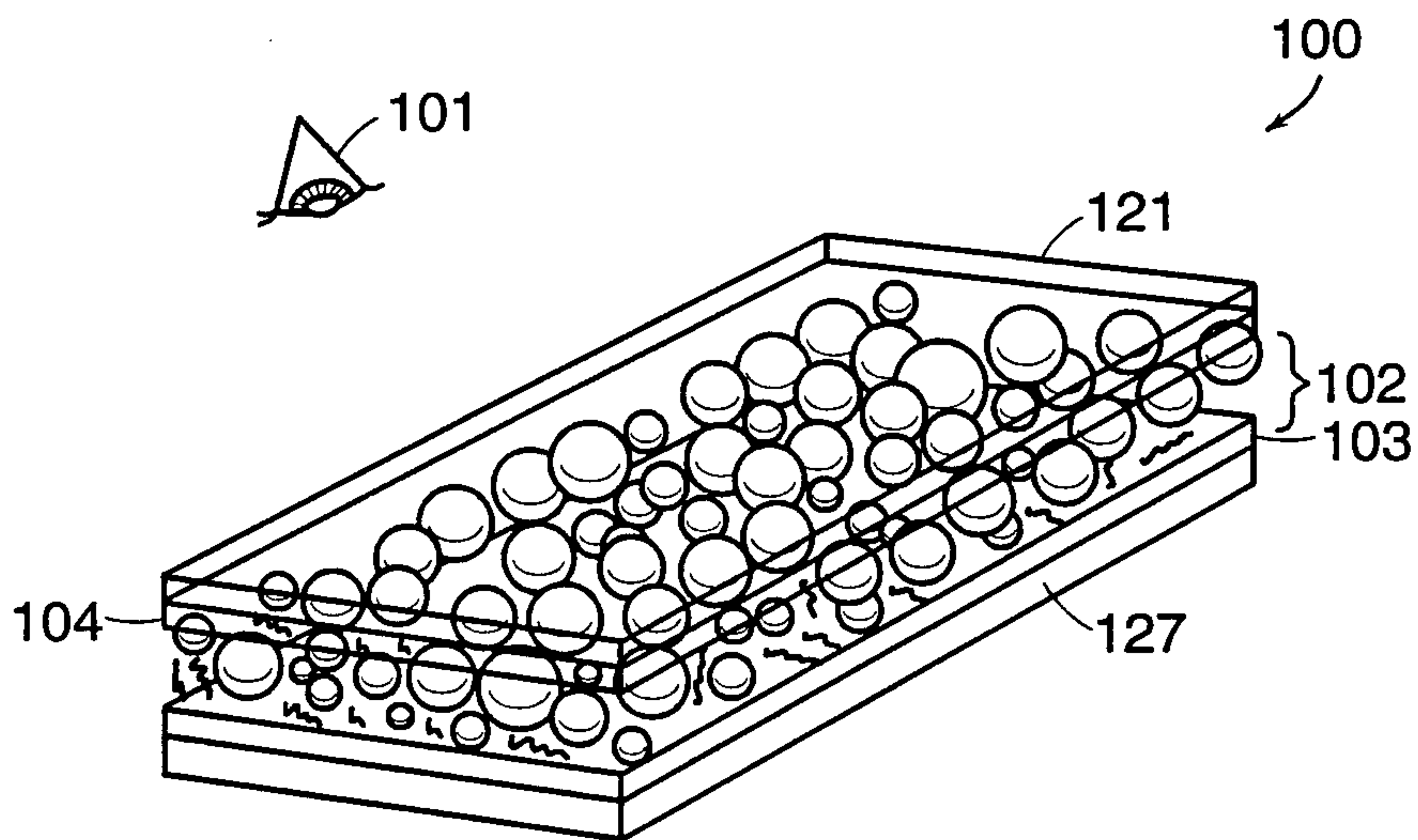

FIG. 2E

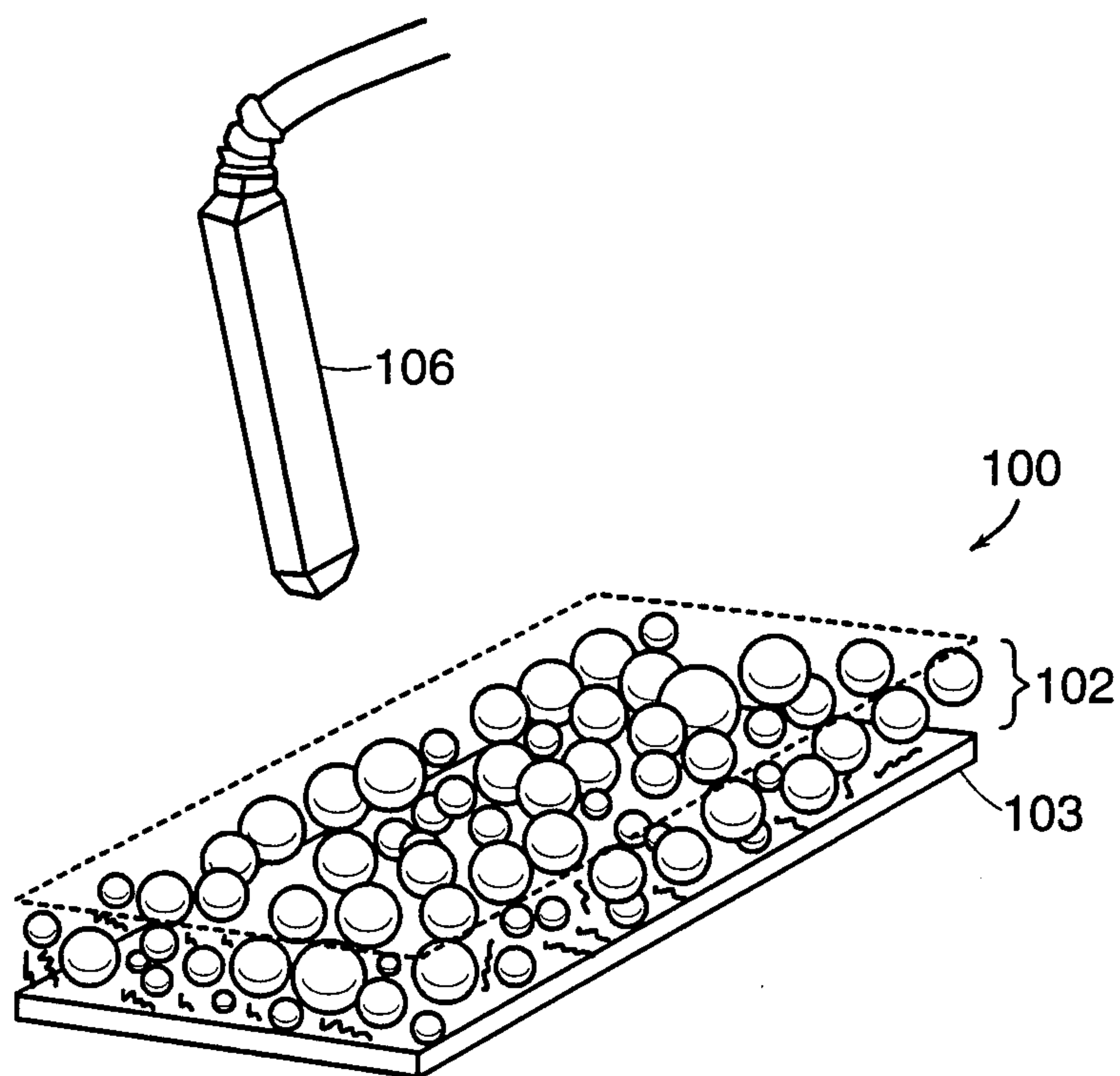

FIG. 2F

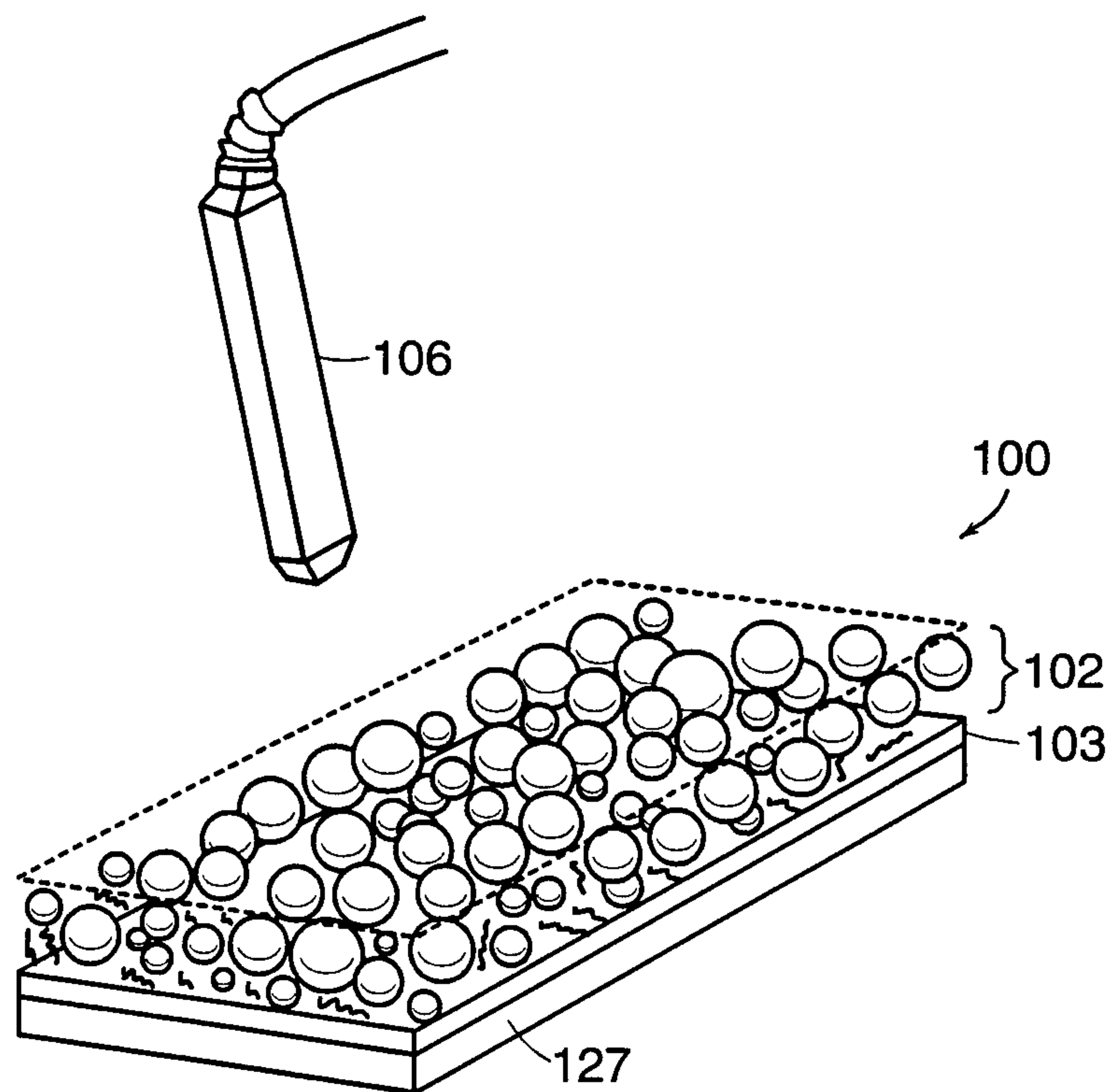

FIG. 2G

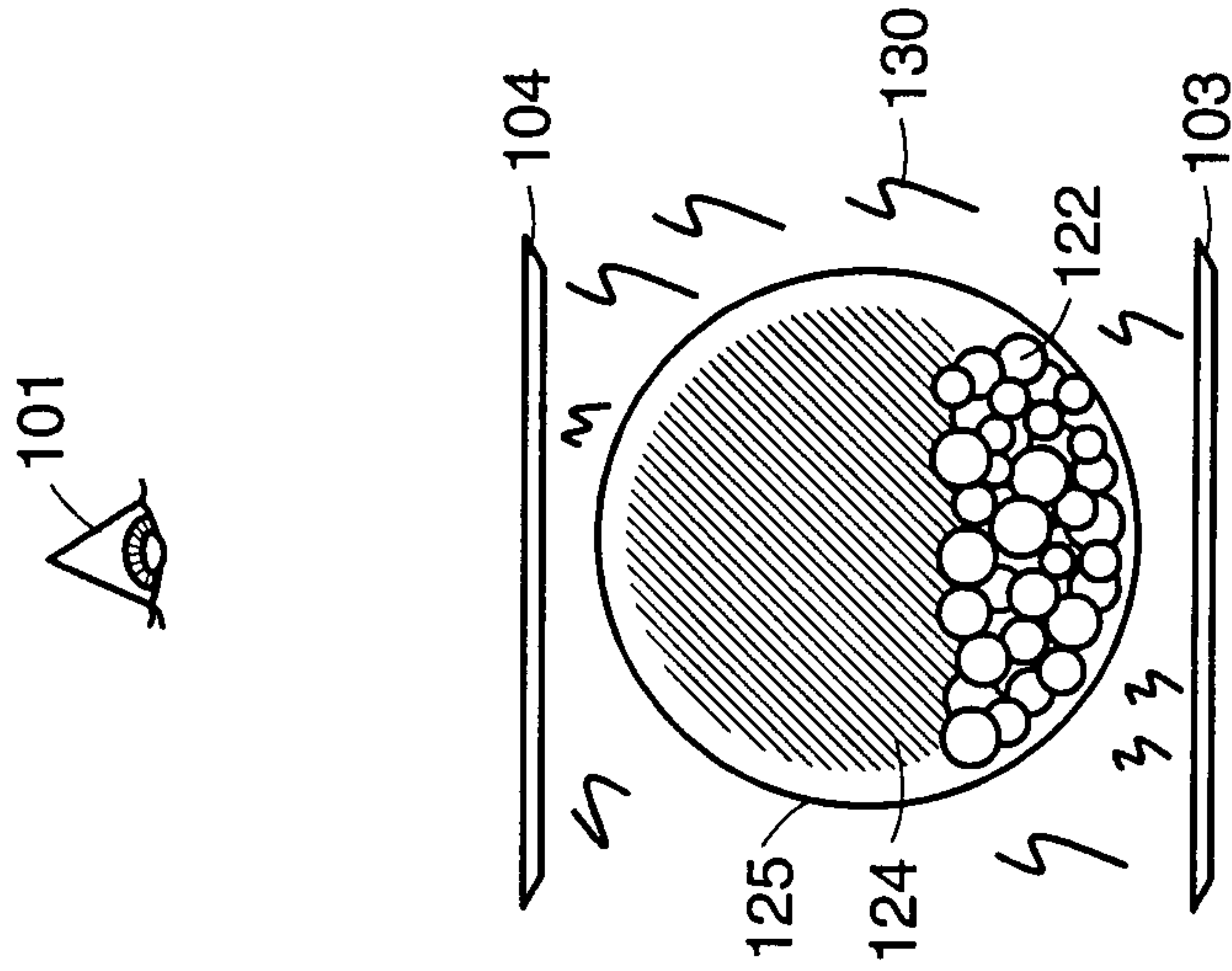

FIG. 3A

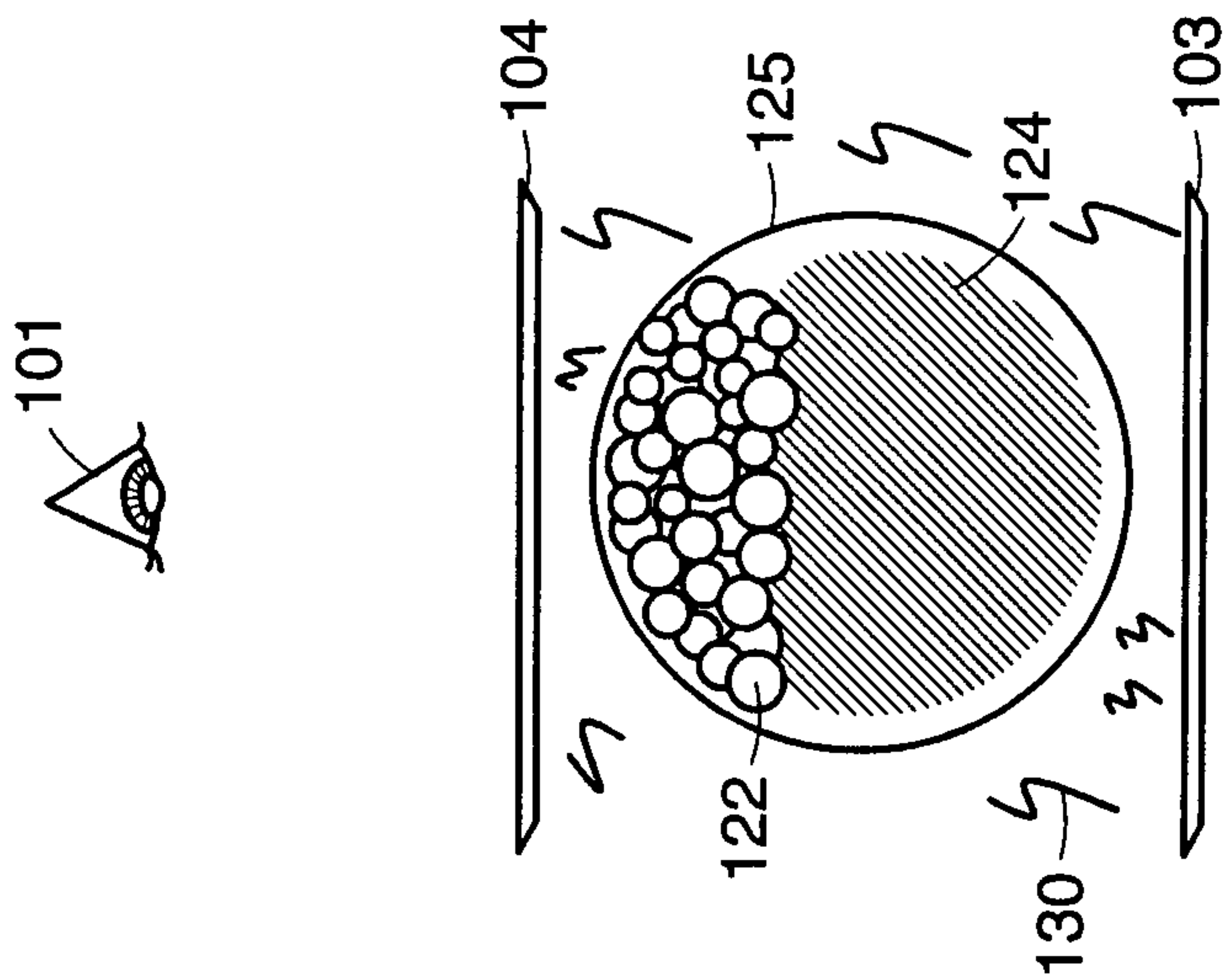
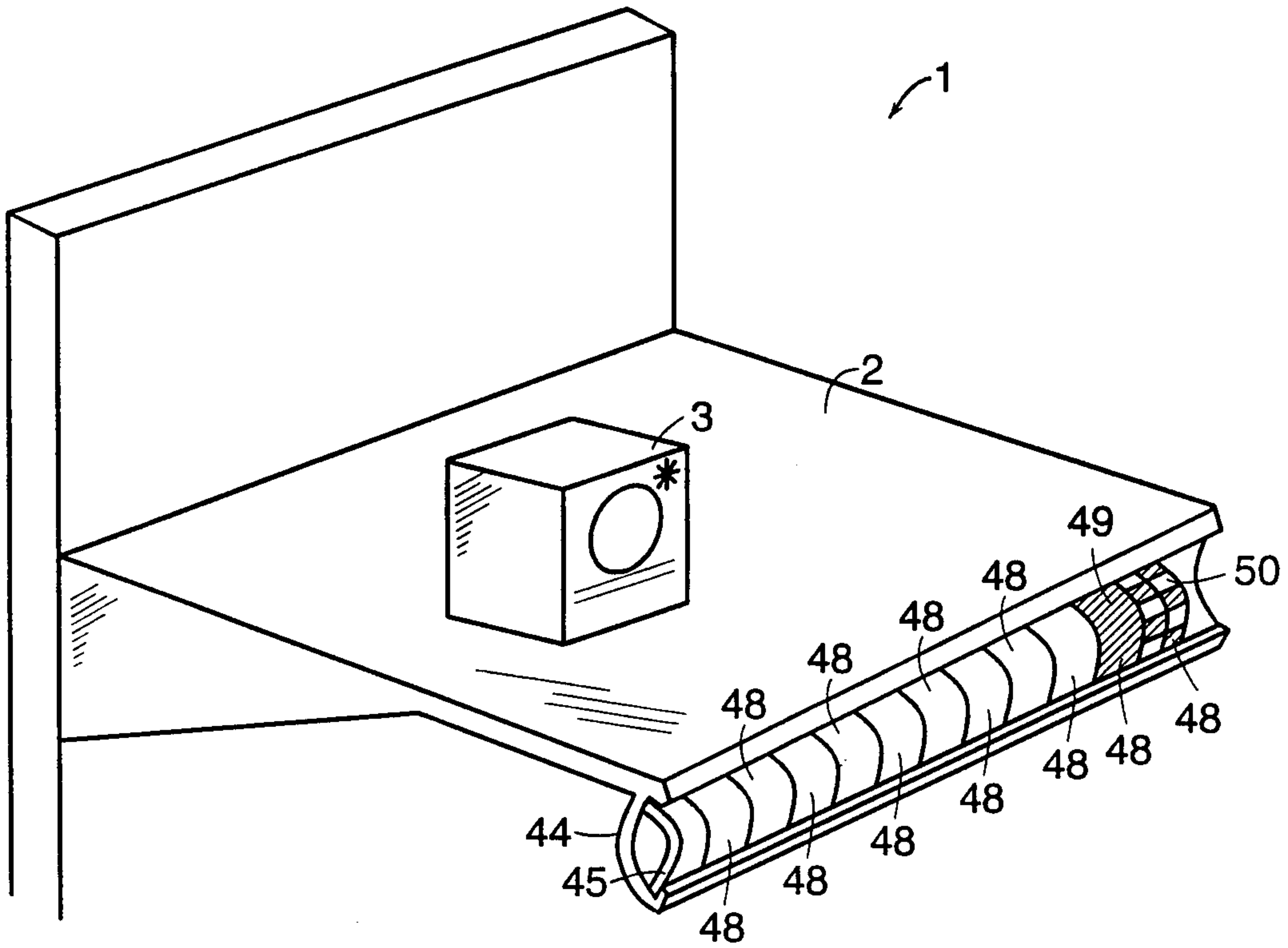
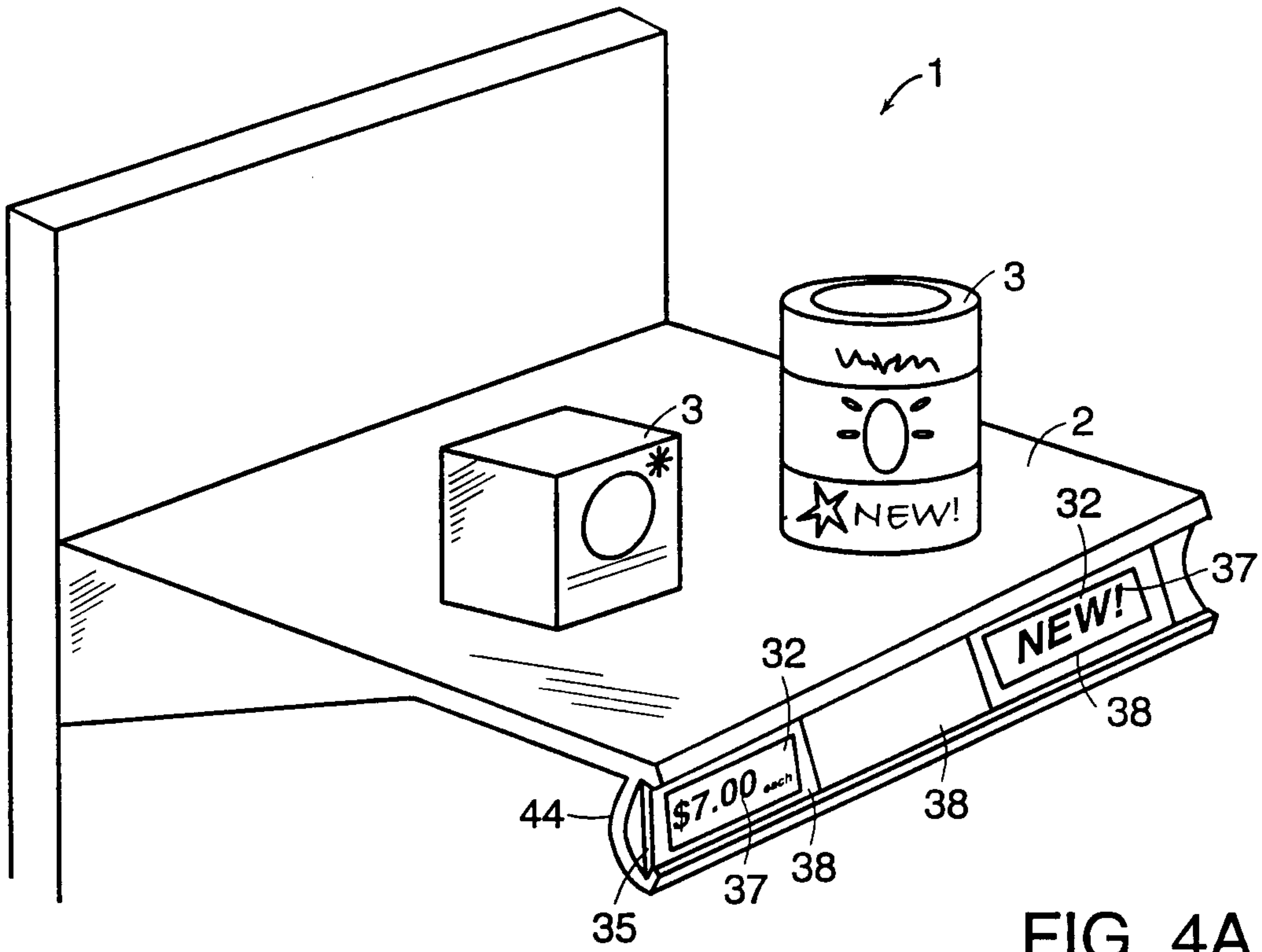

FIG. 3B

8/11



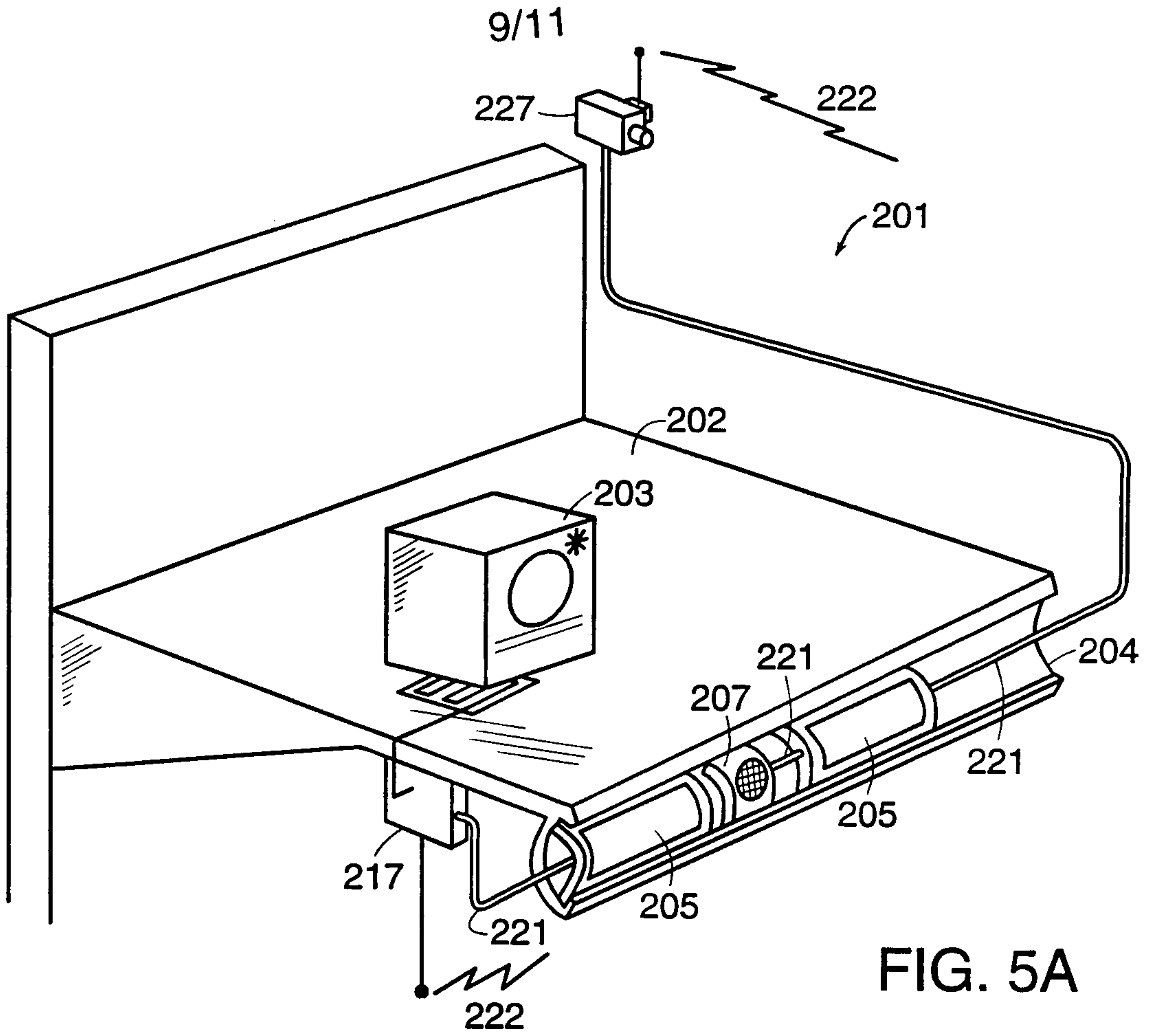

FIG. 5A

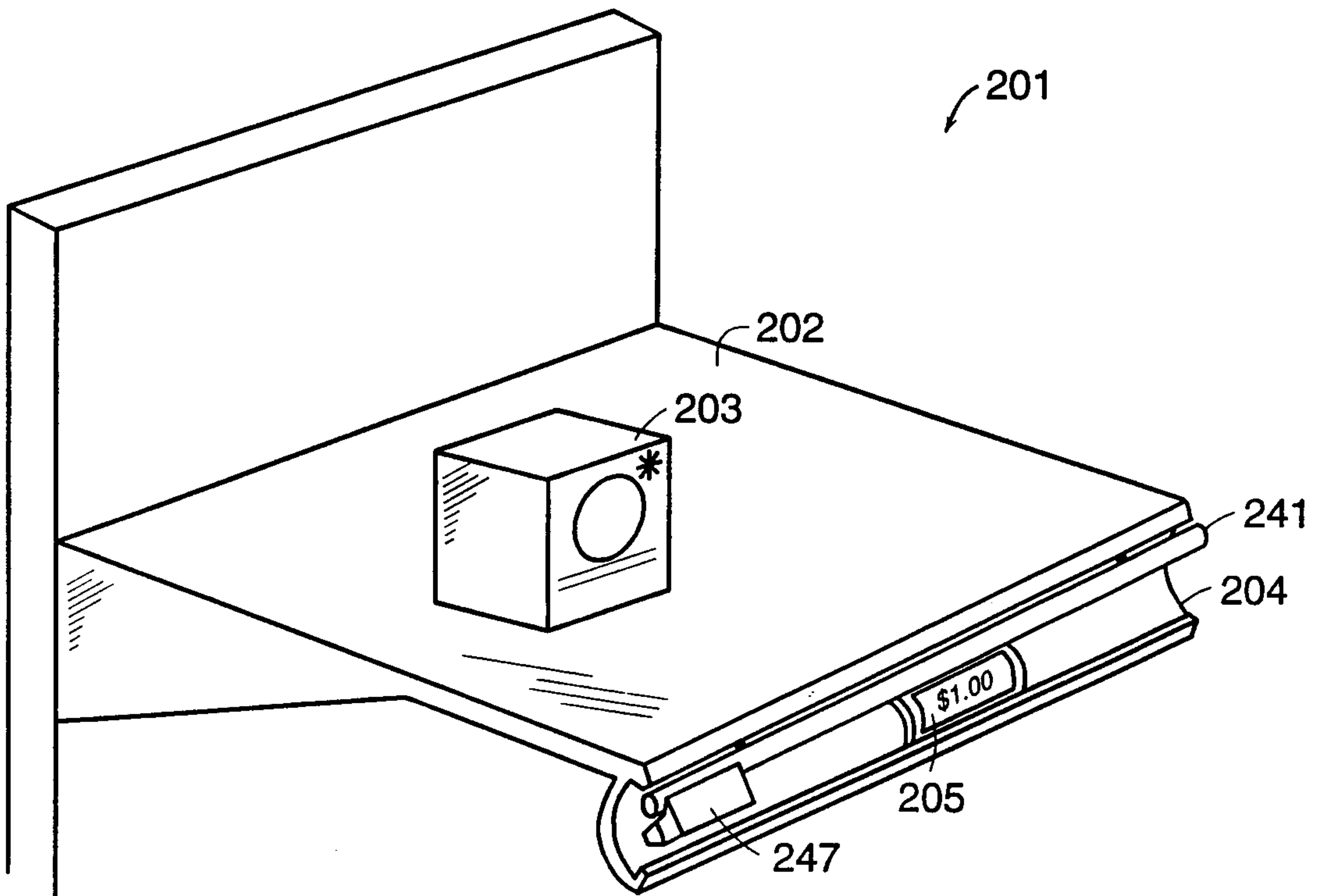
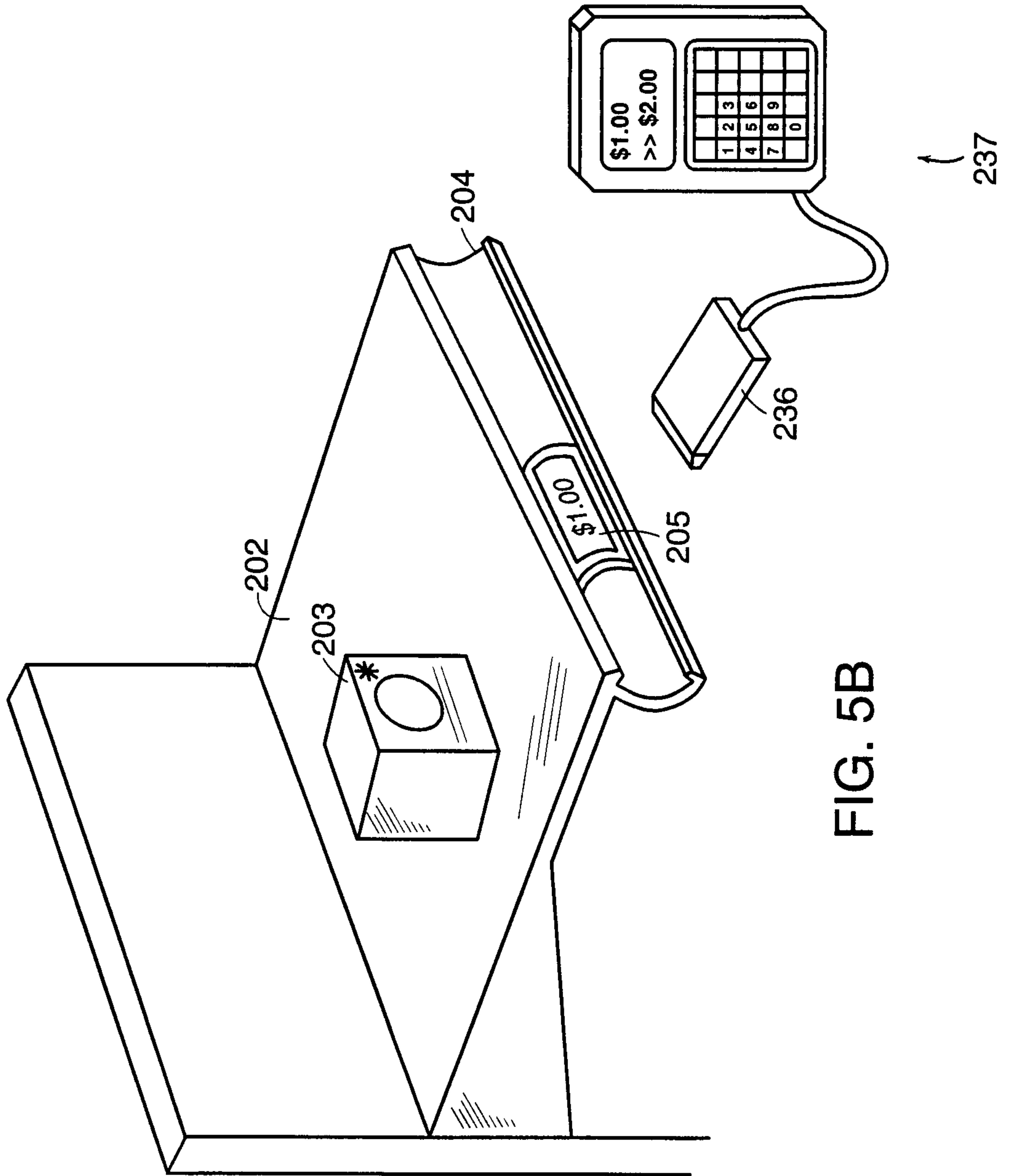

FIG. 5C



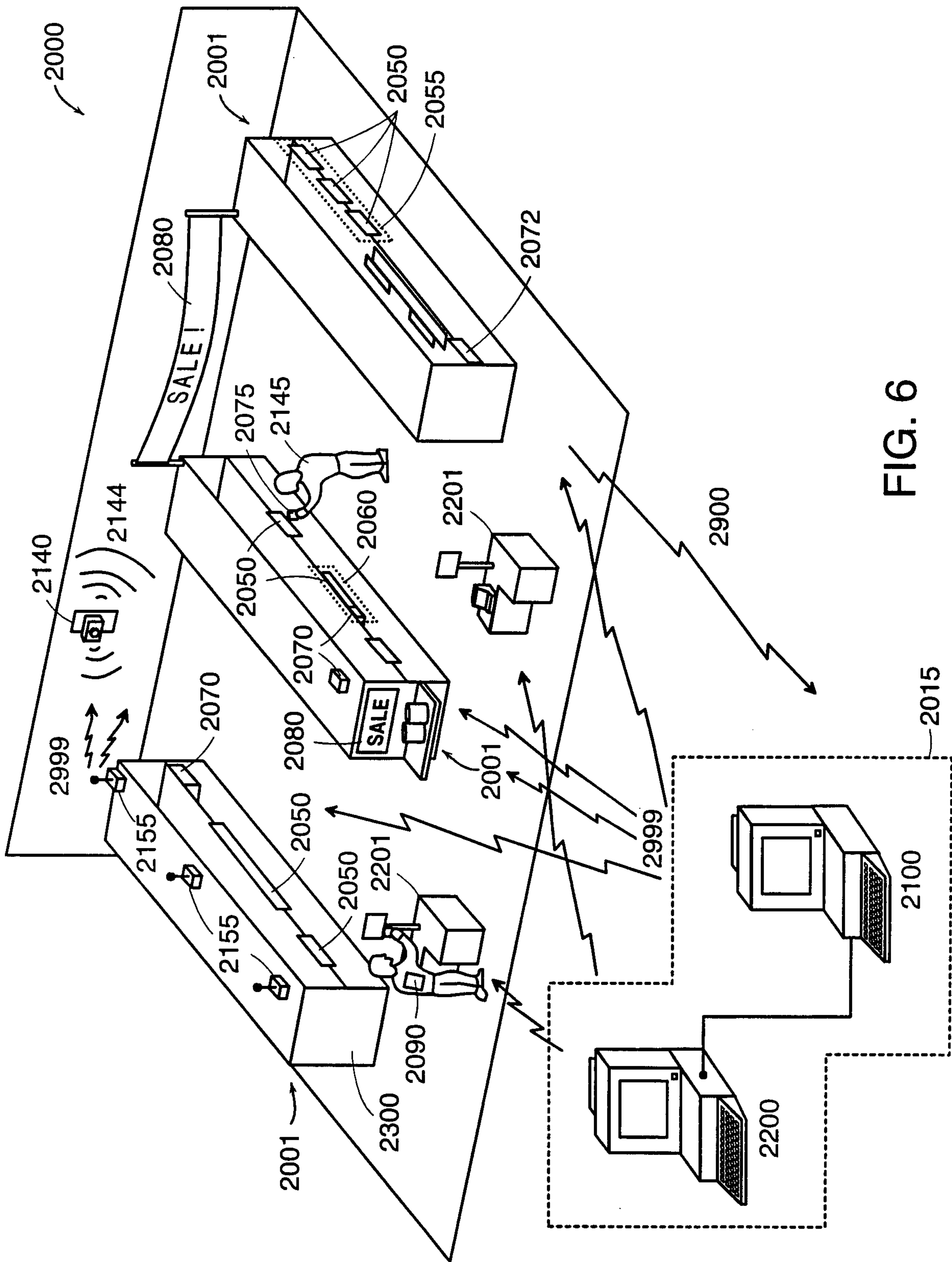

FIG. 6

