

A. WARTH.
Sewing Machine.

No. 55,182.

Patented May 29, 1866.

Fig. 2.

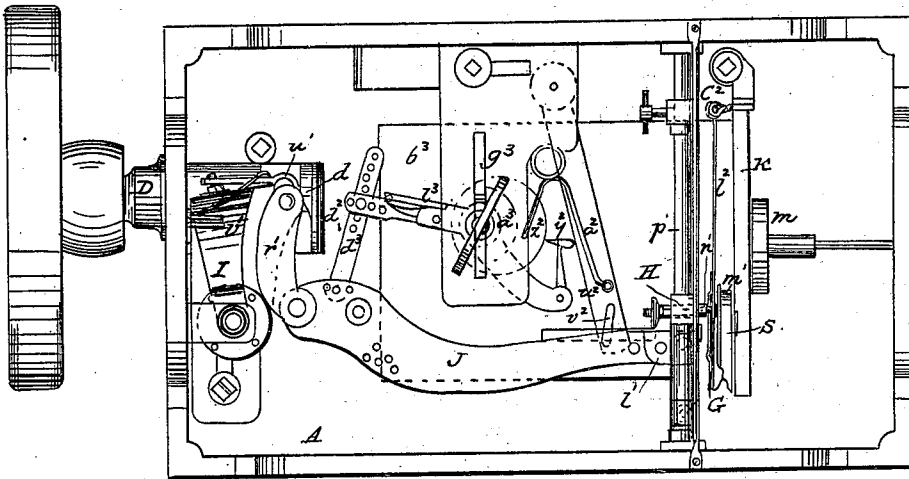
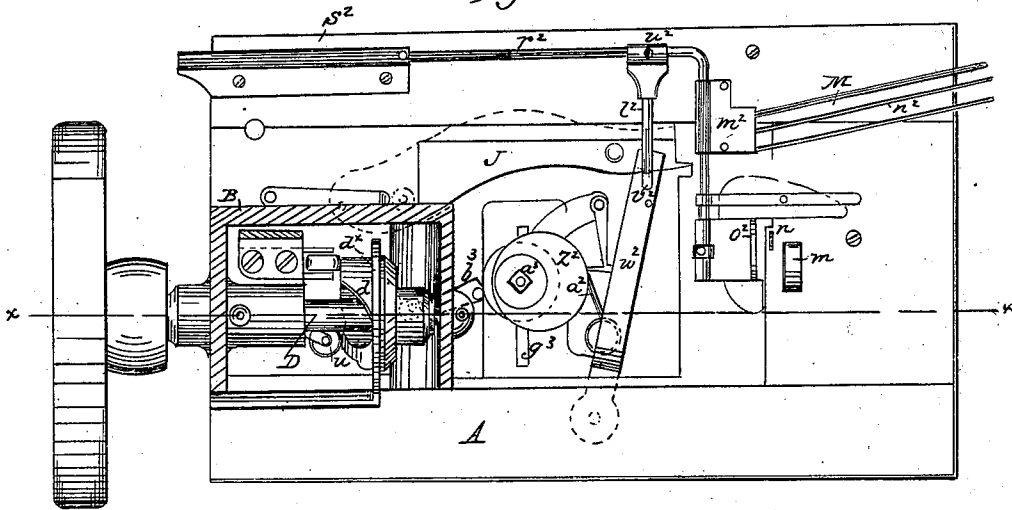

Fig. 3.



Attest.
J. B. Adams
Notary Public

Inventor.
Albin Warth
per Mum & Co
Attorneys

A. WARTH.
Sewing Machine.

No. 55,182.

Patented May 29, 1866.

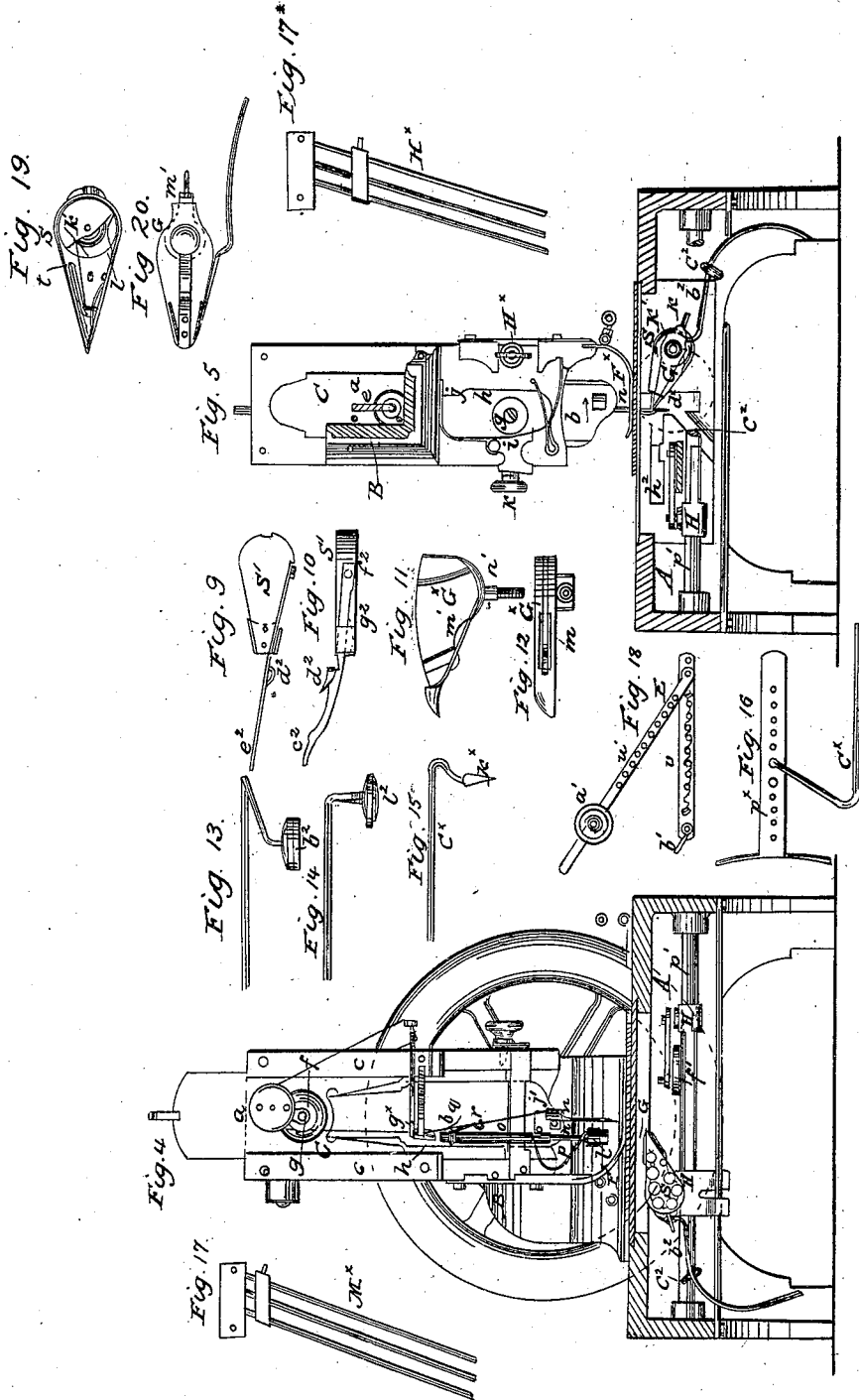

Attest.
[Signature]
For Clerk

Inventor.
Albin Warth
per *[Signature]*
Attorney.

UNITED STATES PATENT OFFICE.

ALBIN WARTH, OF STAPLETON, NEW YORK.

IMPROVEMENT IN SEWING-MACHINES.

Specification forming part of Letters Patent No. 55,182, dated May 29, 1866.

To all whom it may concern:

Be it known that I, ALBIN WARTH, of Stapleton, in the county of Richmond and State of New York, have invented a new and useful Improvement in Sewing-Machines; and I do hereby declare that the following is a full, clear, and exact description thereof, which will enable others skilled in the art to make and use the same, reference being had to the accompanying drawings, forming part of this specification, in which—

Figure 1 represents a longitudinal vertical section of this invention, the line *xx*, Fig. 3, indicating the plane of section. Fig. 2 is an inverted plan of the same. Fig. 3 is a horizontal section of the same, the line *yy*, Fig. 1, indicating the plane of section; Fig. 4, a transverse vertical section of the same, taken in the plane indicated by the line *zz*, Fig. 1, and looking in the direction opposite to that line. Fig. 5 is a similar section, the plane of section being indicated by the line *x'x'*, Fig. 1, and looking in the direction of the arrow opposite to that line.

The remaining views are details, which will be referred to as the description progresses.

Similar letters of reference indicate like parts.

This invention relates to a sewing-machine of that class which, by a simple change in the mechanism, can be adapted so as to produce the lock or the chain stitch. For the purpose of making the loop-stitch a wedge-shaped shuttle is used, which is held in a suitable shoe, and to which a reciprocating curvilinear or rectilinear motion is imparted by suitable mechanism. The tension of the needle-thread is partly regulated by a spring bearing on the surface of the thread on the bobbin and partly by the combination of a hinged and stationary rake and slip-weight, whereby the hinged rake can be made to bear on the thread with more or less power. A peculiar mechanism serves to take up the slack of the needle-thread, and the tension of the shuttle-thread is also regulated by a spring bearing on the circumference of the thread on the bobbin. The feed-motion of the material to be sewed is effected by the action of the needle itself, to which, after it has passed clear down through the material, a lateral motion is imparted; whereby the desired effect on the material is produced. An elastic spring-pad attached to the needle-slide may be used to assist the needle in pro-

ducing the feed-motion. Both the motion of the needle and that of the shuttle are produced by one and the same cam or cam-groove, and if the shuttle is removed from its shoe and a suitable hook put in its place the machine produces the chain-stitch.

This machine is also applicable for the purpose of producing circles, or combinations of circles, or other ornamental designs, by combining with the stitching mechanism an adjustable center of any suitable construction, which guides the material on the surface of which the circles or other designs are to be produced. For a certain class of designs, such as undulating seams, a gage is used, to which a suitable slow reciprocating or oscillating motion is imparted by a design-wheel and spring-slide, or other mechanical means, which enable the operator to produce the desired designs without paying any particular attention to the sewing mechanism.

A represents the stand of my sewing-machine, which is made of metal or any other suitable material. The upper surface of this stand forms the cloth-plate, which serves to support the material to be sewed, and from the rear portion of the stand rises the standard B, the front end of which forms the guide for the needle-slide C, whereas its rear end supports the driving-shaft D of the sewing mechanism. The needle-slide is composed of two parts, *a* *b*, the upper part of which moves up and down between guides *c*, motion being imparted to it by the action of a cam, *d*, and an elbow-lever, *e*, which latter has its fulcrum on a stud, *f*, secured in the standard B, as shown in Fig. 1 of the drawings. The lower part, *b*, of the needle-slide is connected to the upper part so that the same forms a kind of pendulum, which swings in a plane parallel to the direction in which the cloth or other material to be sewed is fed on the cloth-plate. In the lower end of this pendulum the needle *n* is secured, and the length of the vibrations of the pendulum is determined by the action of a roller-stud, *g*, against the edge of a cam-slot, *h*, in the front plate of the standard B. The lower part of this cam-slot forms an inclined plane, *i*, and as the needle-slide descends the roller-stud *g* comes in contact with said inclined plane, and causes the pendulum to swing in the direction marked on it in Fig. 5, and by these means the feed-motion is produced. As the needle-slide ascends the roller-stud *g* strikes an in-

clined plane, *j*, on the opposite edge of the cam-slot *h*, causing the pendulum to reassume its perpendicular position. The inclined plane *i* is adjustable by a set-screw, *k*, so that the feed-motion can be increased or decreased at pleasure.

It will be noticed that the inclined plane *i* is situated near the bottom end of the cam-slot *h*, so that the feed-motion does not take place until the needle has reached its lowest position, and consequently the strain on the needle is brought as close as possible to the point where the needle is supported, and said needle is prevented from being bent. In order to insure a correct feed-motion, however, an elastic spring-pad, *l*, is applied to the outside of the pendulum *b*, and this pad, when let down, presses the cloth or other material to be sewed up against the periphery of a smooth roller, *m*, which is mounted on a suitable arbor or stud below the cloth-plate, and projects somewhat above the surface of the same, as shown in Fig. 1. The pad *l* is secured to the lower end of a stem, *n*, which slides up and down freely in a tubular socket, *o*, secured to the pendulum *b*, and a suitable spring, *p*, depresses said pad upon the material to be sewed. On the upper end of the stem of the pad is a head, *q*, and by placing between this head and the upper end of the tubular socket *o* a semi-cylindrical stop, *r*, the pad can be held in an elevated position when it is not wanted.

It must be remarked that the pad, instead of being placed on the outside of the pendulum, may be so arranged that it acts on the material to be sewed in line with the needle.

The needle-thread, which is shown in red outlines in the various figures, is taken from a spool, *s*, which is inclosed in a hollow globe, *t*, and which rotates on a quill that rises from the bottom of said globe, as shown in Figs. 6 and 7, where Fig. 6 represents a vertical central section of the globe and Fig. 7 a horizontal section of the same. From the inside of the globe projects a spring, *u*, which bears on the surface of the thread wound on the spool, thus producing a certain tension, which is self-regulating, since the power of the spring decreases with the diameter of the roll of thread on which it acts, and vice versa. The globe is made in two halves, the lower half being supported by the standard B or by a statuette secured on said standard, and the upper half being arranged so that it can be readily taken off and replaced. A small hole, *v'''*, in the lower half of the globe allows the thread to pass out to the tension-regulator E, a detached front elevation of which is shown in Fig. 18. This regulator consists of two rakes, *v w*, each of which is provided with a series of round teeth or pins *v''*. The rake *v* is firmly secured to the side of the standard B, and the rake *w* is hinged to the rake *v*, so that when it is closed down its pins pass in between the pins of the stationary rake *v*. On the head of the rake *w* slides a slip-weight, *a'*,

and an adjustable dog, *b'*, secured to the stationary rake *v*, serves to set the hinged rake higher or lower, according to the tension required. If the hinged rake is lowered a larger number of its pins bear on the thread, and the number of the curves formed by said thread is augmented, and consequently the tension is increased. Furthermore, if the weight *a'* is moved out the tension of the thread is increased, and if said weight is moved in the tension is decreased. By the combined action of the slip-weight and dog, therefore, the tension of the needle-thread can be adjusted with the greatest nicety.

From the tension-regulator the thread is carried down to the thread-guide *c'*, which consists of a simple wire secured in the front plate of the standard B, and provided with a loop, through which the thread is passed. After having passed through this loop the thread is carried over a smooth roller, *d'*, which is mounted on an axle having its bearings in a drum or case, *e'*, which is secured to the end of a sleeve, *f'*, fastened by means of a set-screw on the end of a pin, *g'*, which projects from the needle-slide, or the end of the elbow-lever *e* may be made to extend through said needle-slide, so as to form a bearing for the sleeve *f'*. The roller *d'* is made to fit nicely into the case *e'*, but so that it revolves freely on its axis, and it is provided with a circular groove, that forms the guide for the thread. The case is closed on the top, but it is provided with two slots in its sides, through which the thread passes. From the roller *d'* the thread passes down through a guide, *g**, which is formed by a loop in the outer end of a wire projecting from the front plate of the standard B. From the under side of this guide projects a lip, *h'*, and a weak spring, *i*, presses the thread against this lip, so as to prevent the formation of loops on the top of the material to be sewed, as will be presently explained. From the guide *g** the thread passes down through a suitable guide, *j'*, near the bottom end of the pendulum *b*, and thence to the eye of the needle.

The object of the roller *d'* and slotted case *e'* is to take up the slack of the needle-thread. The roller does not strain the thread, and the case prevents the same from jumping off the roller, which it is liable to do, particularly if the machine is run at a high speed.

The spring *i* is necessary to prevent the formation of loops on the upper surface of the material to be sewed. If the needle occupies its highest position and begins to go down the friction of the thread in the eye causes the formation of a loop on the upper surface of the material, and such loops interfere seriously with the correct operation of the stitch-forming mechanism. By the spring *i* the thread is retained just hard enough to overcome the friction of the thread in the eye of the needle, and as the needle moves down the thread slides through its eye, and the formation of loops on the surface of the material to be sewed is prevented. It will be noticed that the spring *i'*

exerts no strain on the thread, and it allows the same to pass down freely as it is required by the stitch-forming mechanism; but it exerts sufficient pressure on the thread to overcome its friction in the eye of the needle, as above explained.

The stitch is locked either by a lower thread or by the formation of a chain on the under surface of the material to be sewed. In the former case a shuttle, S, is used, the form of which can be seen in Figs. 2, 4, 5, and 19. It is made wedge-shaped, with a rounded stern and pointed bow, and it carries a small bobbin, k' , on which the shuttle-thread is wound.

A spring, l' , bearing on the surface of the thread wound on the bobbin k' , produces a self-adjusting friction, which is uniform until all the thread is used up, because the power of the spring decreases in the same proportion in which the diameter of the roll of thread on which it acts decreases.

From the bobbin k' the shuttle-thread is drawn under a pin in the narrow end of the shuttle, and thence it is wound one or more times round a wire, l'' , extending from the solid bow of the shuttle parallel to one of its sides, and this side is perforated with four (more or less) small holes, through one or more of which the shuttle-thread is passed, so that the requisite tension of said thread is obtained.

The sole of the shuttle is perforated with a number of large holes, so as to reduce its weight, and said shuttle is carried by a shoe, G, a detached view of which is shown in Fig. 20. This shoe is provided with a spring-catch, m' , which drops into a notch in the stern of the shuttle, and a stem, n' , which projects from its back, is fitted into a socket, o' , which is secured to a reciprocating sleeve or carriage, H. This sleeve is fitted on a guide-rod, p' , which extends transversely through the stand A, (see Fig. 4,) and it receives its motion by the action of the same cam d , which also produces the motion of the needle-slide C, said cam being made to act on a swivel-arm, I, which connects by a link, r' , with a lever, J, as seen in Fig. 2. This lever has its fulcrum on a pivot, s' , secured in the bottom of the stand A, and its front end connects by a short link, t' , (see Fig. 4,) with the shuttle-driver sleeve H.

The swivel-arm I is mounted on a vertical rock-shaft, J' , and it is armed with a friction-roller, w' , which is held in contact with the cam d by the action of a spring, v' . In the same manner the elbow-lever e is also provided with a friction-roller, w' , which is held in contact with the cam by the action of a spring, a^2 . (See Fig. 1.) The springs v' and a^2 may, however, be dispensed with if, instead of the cam d , a cam-groove is used which straddles the friction-rollers $w' w'$, so that a positive motion is imparted to the elbow-lever e and to the lever J in either direction.

From the rear end of the shoe G extends a curved rod, b^2 , through a staple or eye, c^2 , as shown particularly in Figs. 4 and 5 of the drawings. By the action of this rod an oscil-

lating motion is imparted to the shoe, and the point of the shuttle is thrown up when the shoe recedes and down as the shoe advances, and by this motion of the shuttle the point thereof is enabled to enter the loop of the needle-thread at a point comparatively close to the under surface of the cloth-plate, and the length of the needle can be reduced without disturbing the correct operation of the stitch-making mechanism.

The sole of the shuttle bears against the vertical abutment or shuttle-race K, which extends partially across the stand A, as clearly shown in Figs. 2 and 5 of the drawings, and in order to prevent the sole of the shuttle from rubbing against and injuring that portion of the needle-thread which passes through between said sole and the shuttle-race, a cavity, c^{2*} , is made in said shuttle-race, as shown in Figs. 1 and 4. In this cavity that portion of the needle-thread which passes between the shuttle-race and the sole of the shuttle will lodge, and the shuttle passes through the loop of the needle-thread without causing any injury to the same. Another cavity, d^{2*} , in the shuttle-race gives room for the needle to pass down, the sole of the shuttle being pressed up closely against the shuttle-race, and this cavity is made wide enough to permit the feed-motion of the needle.

Instead of arranging the shuttle so that its sole bears against the shuttle-race, the shoe G* might be constructed as shown in Figs. 11 and 12 of the drawings, where Fig. 11 represents a plan or top view, and Fig. 12 a side elevation. This shoe is provided with a spring-catch, m' , and stem n' , the same as that shown in Fig. 20; but the stem emanates from its side instead of from its bottom, and the shuttle is placed into this shoe so that its side bears against the shuttle-race.

If a chain-stitch is to be produced instead of the lock-stitch, the shuttle S is removed from the shoe G and a false shuttle, S', put in its place. This false shuttle is shown in Figs. 9 and 10 of the drawings, where Fig. 9 represents a plan, and Fig. 10 a side, elevation. It is provided with a hook, d^2 , and tongue e^2 , which are formed of one solid piece of sheet-steel, or other suitable material, being secured to the false shuttle by a pivot, f^2 . The edge of the tongue e^2 is pressed up against the shuttle-race K by means of a weak spring, g^2 , (see Fig. 10,) and a cavity, h^2 , in the shuttle-race allows the tongue and hook to assume such a position that the hook catches into the loop of the needle-thread without fail at the proper time.

It has been remarked that motion is imparted to the needle-slide C and the shuttle-driver J by one and the same cam, d , a detached front elevation of which is shown in Fig. 8. The working-surface of this cam is so shaped that by its action on the elbow-lever e and shuttle-driver J the requisite motion of the needle-slide and of the shuttle is produced. By the use of one and the same cam for the purpose of imparting motion to the needle-

slide, and also to the shuttle-driver, the construction of the machine is greatly simplified, and if the cam is made in the proper shape the machine will work correctly for a long time, and its principal working parts are not liable to wear out.

It is obvious that all these advantages are retained if a cam-groove is used in place of the surface-cam shown in the drawings.

When the machine is adjusted to make the chain-stitch the friction-roller w' , in the end of the swivel-arm I, must be so adjusted that it bears on the surface of the cam d^* instead of that on the cam d . The cam d^* is mounted on the same shaft on which the cam d is mounted, and the arm which forms the bearing for the friction-roller w' is adjustable, so that said roller can be readily set to bear on the cam d or on the cam d^* , as may be desirable.

After the needle has been threaded, as above described, and the shuttle S or S' adjusted in the shoe G, the machine is ready for sewing. The tension of the needle-thread and of the shuttle-thread must be regulated according to the material to be sewed, and said material is placed on the cloth-plate, the foot F* is let down by turning the handle H*, and the operation of sewing can commence. As the needle descends it feeds the fabric, and after it has reached its lowest position it recedes by the action of the spring a^2 , thus forming a loop into which the point of the shuttle catches, and while the needle remains stationary the shuttle is passed through said loop, which it opens by reason of its wedge-shaped form. By this action the previous stitch is drawn tight, and as soon as the shuttle has passed through the loop the needle ascends, and then the shuttle recedes slightly and advances again, thereby allowing the needle-thread to drop off freely, and, finally, the shuttle recedes and the stitch is finished. During this operation both threads are relieved, and stretched simultaneously, and a tight and clean stitch is produced.

Provision is also made in my machine to sew circles and other designs automatically, and without the necessity of marking them before the sewing commences and of paying particular attention to them while sewing.

For the purpose of sewing circles or designs composed of circles, I use an adjustable center, C*, which is inserted into a socket, z^2 , secured to the shank of the foot F*, and provided with a set-screw, j^2 , by means of which the center can be held in the desired position. Said center may be made in various forms, either with a point, k^2 , as shown in Fig. 15, or with a revolving pad, l^2 , as shown in Figs. 13 and 14, and the pad may be connected to the arm in many different ways, two of which are shown in the figures before mentioned. If desired, an extension attachment, l^2* , may be connected to the arm of the center, such as shown in Fig. 16, and thereby the radius of the circles may be increased to any desired extent. The distance of the center from the needle de-

termines the radius of the circle to be sewed, and by the feed-motion of the needle the material to be sewed is caused to turn round the center, and consequently a circular seam is produced on the material.

Any design composed of a combination of circles or parts of circles can be produced by the aid of this adjustable center.

In order to produce designs of any other desirable description, such as undulating or curved lines, I use a cloth-guide, M, which is composed of a head, m^2 , from which extend three prongs, n^2 , in an oblique direction, so that the fabric passing through between them is carried up against the gage e^2 . The gage and guide are mounted on an angular shank, p^2 , which is secured in a socket, s^2 , and from said shank extends a tappet, t^2 , which is adjustable by a set-screw, u^2 . Said tappet extends down through a slot in the top plate of the stand A, and it catches into a slot, v^2 , in a lever, w^2 . This lever is forced by means of a spring, x^2 , against the back of a tracer, y^2 , the point of which bears against the periphery of the design-wheel z^2 . This wheel is mounted on an arbor, a^3 , (see Fig. 3,) and an intermittent revolving motion is imparted to it by suitable mechanism from the swivel-arm I or shuttle-driving lever J.

In the drawings, a spring-dog, b^3 , is shown, the point of which bears on the circumference of a circular disk, c^3 , that is connected to the arbor a^3 or to the design-wheel z^2 , and a vibrating motion is imparted to said spring-dog by a rod, d^3 , which is pivoted to the shuttle-driver J, as shown in Fig. 2.

I do not wish to confine myself, however, to this particular mechanism to produce the motion of the design-wheel, since this motion can be produced in different ways, as above stated.

The arbor a^3 of the design-wheel is adjustable in a slotted bracket, g^3 , and thereby one and the same design-wheel is enabled to produce a variety of designs. The form of the design-wheel shown in the drawings is simply an eccentric disk; but it is obvious that this disk may be replaced by a wheel of any other suitable or desirable shape or design.

With the cloth-guide M additional cloth-guides M* and M* may be combined, such as shown in Figs. 17 and 17*, and thereby I am enabled to sew different thicknesses of cloth or other material together, or to sew braid to the surface of cloth, leather, or other fabric, and to produce designs of any desired description.

What I claim as new, and desire to secure by Letters Patent, is—

1. The combination of the rakes v w , teeth or pins v'' , slip-weight a' , and adjustable dog b' , arranged and operating in the manner and for the purpose herein specified.

2. The elastic pad l , in combination with the needle-slide C, pendulum b , and needle n , constructed and operating substantially as and for the purpose set forth.

3. The perforated flat sole-shuttle S, in com-

ination with the shoe G and needle *n*, arranged and operating in the manner and for the purpose herein described.

4. The combination of the curved tail-piece *b*² and shuttle S, for the purpose herein described.

5. The false shuttle S', with tongue *e*² and hook *d*², in combination with the shoe G and needle *n*, constructed and operating substantially as and for the purpose described.

6. The cavity *h*² *d*^{2*}, in combination with the hook *d*² and needle *n*, as described, so that the loop can be brought in such a position as to allow the needle to pass through it on its subsequent descent.

7. The cavity *c*^{2*}, located as shown, in combination with the sole of the shuttle and the shuttle-race, constructed and operating substantially as and for the purpose set forth.

8. The tracer *y*² and adjustable cloth-guide M, in combination with the design-wheel *z*² and with a sewing mechanism constructed and operating substantially as and for the purpose described.

ALBIN WARTH.

Witnesses:

M. M. LIVINGSTON,
W. HAUFF.