



US00D787326S

(12) **United States Design Patent**
Hanson et al.

(10) **Patent No.:** **US D787,326 S**

(45) **Date of Patent:** **** May 23, 2017**

(54) **CAP WITH ACTUATOR**

51/04; B65D 83/205; B65D 83/206;
B05B 17/00; B05B 15/002

(71) Applicant: **Homax Products, Inc.**, Bellingham,
WA (US)

See application file for complete search history.

(72) Inventors: **Randal W. Hanson**, Bellingham, WA
(US); **Robert A. Kinzle**, Polson, MT
(US)

(56) **References Cited**

(73) Assignee: **PPG Architectural Finishes, Inc.**,
Pittsburgh, PA (US)

U.S. PATENT DOCUMENTS

(**) Term: **14 Years**

(21) Appl. No.: **29/511,295**

(22) Filed: **Dec. 9, 2014**

(51) **LOC (10) Cl.** **09-07**

(52) **U.S. Cl.**
USPC **D9/448; D23/225**

(58) **Field of Classification Search**
USPC D3/201, 202, 203.1; D7/392.1, 397, 398;
D9/417, 423, 434, 435, 436, 440, 447,
D9/448, 449, 454, 682, 685, 686, 724,
D9/725, 730, 745, 906; D29/126;
D15/7, 9, 9.1; D23/206, 211.1, 213, 223,
D23/229, 231; 239/120, 215, 302, 308,
239/310, 332, 333, 337, 526, 373, 394,
239/459, 465.1, 383.1, 539; 222/143,
222/154, 323, 383.1, 383.3, 401, 402, 15,
222/465.1; 206/38, 45, 223, 210, 232,
206/387.11, 439, 457, 459.1, 495.531,
206/581; D6/516; 417/178, 198, 419
CPC A45D 34/00; A45D 34/042; A45D 40/22;
A45D 2040/0006; A45D 2040/0093;
A47G 19/22; A47G 19/2205; A47G
19/2255; A47G 19/2266; A62C 31/02;
B65D 1/02; B65D 1/0223; B65D 1/08;
B65D 1/10; B65D 23/00; B65D 23/08;
B65D 25/00; B65D 25/40; B65D 25/42;
B65D 25/46; B65D 25/48; B65D 25/77;
B65D 39/00; B65D 39/0047; B65D
41/00; B65D 43/02; B65D 51/02; B65D

208,330 A	9/1878	Palmer
351,968 A	11/1886	Derrick
D25,916 S	8/1896	Woods
568,876 A	10/1896	Regan
579,418 A	3/1897	Bookwalter
582,397 A	5/1897	Shone
604,151 A	5/1898	Horn
625,594 A	5/1899	Oldham
658,586 A	9/1900	Reiling
930,095 A	8/1909	Seagrave
931,757 A	8/1909	Harmer
941,671 A	11/1909	Campbell
1,093,907 A	4/1914	Birnbaum
1,154,974 A	9/1915	Custer
1,162,170 A	11/1915	Johnson
1,294,190 A	2/1919	Sturcke
1,332,544 A	3/1920	Davis
1,486,156 A	3/1924	Needham
1,590,430 A	6/1926	Erby
1,609,465 A	12/1926	Day
1,643,969 A	10/1927	Tittlemore et al.
1,650,686 A	11/1927	Binks
1,656,132 A	1/1928	Arrasmith et al.
1,674,510 A	6/1928	Hagman
1,755,329 A	4/1930	McCormack
1,770,011 A	7/1930	Poston
1,809,073 A	6/1931	Schylander
1,863,924 A	6/1932	Dunn
1,988,017 A	1/1935	Norwick
2,127,188 A	8/1938	Schellin et al.
2,149,930 A	3/1939	Plastaras
2,197,052 A	4/1940	Lowen
2,198,271 A	4/1940	McCallum
D134,562 S	12/1942	Murphy
2,305,269 A	12/1942	Moreland
2,307,014 A	1/1943	Becker et al.
2,320,964 A	6/1943	Yates
2,353,318 A	7/1944	Scheller
2,361,407 A	10/1944	McNair
2,388,093 A	10/1945	Smith
2,530,808 A	11/1950	Cerasi
2,565,954 A	8/1951	Dey
2,612,293 A	9/1952	Michel
2,686,652 A	8/1954	Carlson et al.
2,704,690 A	3/1955	Eichenauer

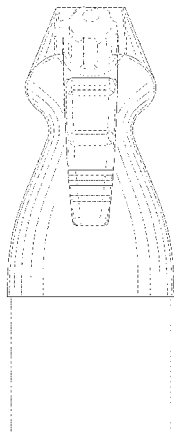

US D787,326 S

Page 2

2,723,200 A	11/1955	Pyenson	3,698,645 A	10/1972	Coffey
2,763,406 A	9/1956	Countryman	3,700,136 A	10/1972	Ruekberg
2,764,454 A	9/1956	Edelstein	3,703,994 A	11/1972	Nigro
2,785,926 A	3/1957	Lataste	3,704,811 A	12/1972	Harden, Jr.
2,790,680 A	4/1957	Rosholt	3,704,831 A	12/1972	Clark
2,801,880 A	8/1957	Rienecker	3,705,669 A	12/1972	Cox et al.
2,831,618 A	4/1958	Soffer et al.	3,711,030 A	1/1973	Jones
2,839,225 A	6/1958	Soffer et al.	3,756,732 A	9/1973	Stoffler
2,887,274 A	5/1959	Swenson	3,764,067 A	10/1973	Coffey et al.
2,908,446 A	10/1959	Strouse	3,770,166 A	11/1973	Marand
2,923,481 A	2/1960	Pinke	3,773,706 A	11/1973	Dunn, Jr.
2,932,434 A	4/1960	Abplanalp	3,776,470 A	12/1973	Tsuchiya
2,962,743 A	12/1960	Henriksson	3,776,702 A	12/1973	Chant
2,965,270 A	12/1960	Soffer et al.	3,777,981 A	12/1973	Probst et al.
2,968,441 A	1/1961	Holcomb	3,788,521 A	1/1974	Laauwe
2,976,897 A	3/1961	Beckworth	3,788,526 A	1/1974	Thornton et al.
2,997,243 A	8/1961	Kolb	3,795,366 A	3/1974	McGhie et al.
2,999,646 A	9/1961	Wagner	3,797,946 A	3/1974	Witzmann et al.
3,016,561 A	1/1962	Hulsh	3,799,398 A	3/1974	Morane et al.
3,027,096 A	3/1962	Giordano	3,806,005 A	4/1974	Prussin et al.
3,032,803 A	5/1962	Walshauer	3,811,369 A	5/1974	Ruegg
3,061,203 A	10/1962	Kitabayashi	3,813,011 A	5/1974	Harrison et al.
3,072,953 A	1/1963	Bunke	3,814,326 A	6/1974	Bartlett
3,083,872 A	4/1963	Meshberg	3,819,119 A	6/1974	Coffey et al.
3,107,059 A	10/1963	Frechette	3,828,977 A	8/1974	Borchert
3,116,856 A	1/1964	Prussin et al.	3,848,778 A	11/1974	Meshberg
3,116,879 A	1/1964	Wagner	3,848,808 A	11/1974	Fetty et al.
3,121,906 A	2/1964	Hulsh	3,862,705 A	1/1975	Beres et al.
3,135,007 A	6/1964	Howell	3,871,553 A	3/1975	Steinberg
3,148,806 A	9/1964	Meshberg	3,876,154 A	4/1975	Griebel
3,157,360 A	11/1964	Heard	3,891,128 A	6/1975	Smrt
3,167,525 A	1/1965	Thomas	3,899,134 A	8/1975	Wagner
3,191,809 A	6/1965	Schultz et al.	3,912,132 A	10/1975	Stevens
3,196,819 A	7/1965	Lechner et al.	3,913,803 A	10/1975	Laauwe
3,198,394 A	8/1965	Lefer	3,913,804 A	10/1975	Laauwe
3,207,444 A	9/1965	Kelley et al.	3,913,842 A	10/1975	Singer
3,216,628 A	11/1965	Fergusson	D237,796 S	11/1975	Wagner
3,236,459 A	2/1966	McRitchie	3,932,973 A	1/1976	Moore
3,246,850 A	4/1966	Bourke	3,936,002 A	2/1976	Geberth, Jr.
3,258,208 A	6/1966	Greenebaum, II	3,938,708 A	2/1976	Burger
3,271,810 A	9/1966	Raffe	3,945,571 A	3/1976	Rash
3,284,007 A	11/1966	Clapp	3,961,756 A	6/1976	Martini
3,305,144 A	2/1967	Beres et al.	3,975,554 A	8/1976	Kummins et al.
3,307,788 A	3/1967	Ingram	3,982,698 A	9/1976	Anderson
3,311,274 A	3/1967	Green	3,987,811 A	10/1976	Finger
3,314,571 A	4/1967	Greenebaum, II	3,989,165 A	11/1976	Shaw et al.
3,317,140 A	5/1967	Smith	3,991,916 A	11/1976	Del Bon
3,342,382 A	9/1967	Huling	3,992,003 A	11/1976	Visceglia et al.
3,346,195 A	10/1967	Groth	4,010,134 A	3/1977	Braunisch et al.
3,373,908 A	3/1968	Crowell	4,032,064 A	6/1977	Giggard
3,377,028 A	4/1968	Bruggeman	4,036,438 A	7/1977	Soderlind et al.
3,390,121 A	6/1968	Burford	4,036,673 A	7/1977	Murphy et al.
3,405,845 A	10/1968	Cook et al.	4,045,860 A	9/1977	Winckler
3,414,171 A	12/1968	Grisham et al.	4,058,287 A	11/1977	Fromfield
3,415,425 A	12/1968	Knight et al.	4,078,578 A	3/1978	Buchholz
3,425,600 A	2/1969	Abplanalp	4,089,443 A	5/1978	Zrinyi
3,428,224 A	2/1969	Eberhardt et al.	4,096,974 A	6/1978	Haber et al.
3,433,391 A	3/1969	Krizka et al.	4,117,951 A	10/1978	Winckler
3,445,068 A	5/1969	Wagner	4,123,005 A	10/1978	Blunk
3,450,314 A	6/1969	Gross	4,129,448 A	12/1978	Greenfield et al.
3,467,283 A	9/1969	Kinnavy	4,147,284 A	4/1979	Mizzi
3,472,457 A	10/1969	McAvoy	4,148,416 A	4/1979	Gunn-Smith
3,482,738 A	12/1969	Bartels	4,154,378 A	5/1979	Paoletti et al.
3,491,951 A	1/1970	Knibb	4,159,079 A	6/1979	Phillips, Jr.
3,498,541 A	3/1970	Taylor, Jr. et al.	4,164,492 A	8/1979	Cooper
3,513,886 A	5/1970	Easter et al.	RE30,093 E	9/1979	Burger
3,514,042 A	5/1970	Freed	4,171,757 A	10/1979	Diamond
3,544,258 A	12/1970	Presant et al.	4,173,558 A	11/1979	Beck
3,548,564 A	12/1970	Bruce et al.	4,185,758 A	1/1980	Giggard
3,550,861 A	12/1970	Teson	4,187,959 A	2/1980	Pelton
3,575,319 A	4/1971	Safianoff	4,187,985 A	2/1980	Goth
3,592,359 A	7/1971	Marraffino	4,195,780 A	4/1980	Inglis
3,596,835 A	8/1971	Smith	4,198,365 A	4/1980	Pelton
3,608,822 A	9/1971	Berthoud	4,202,470 A	5/1980	Fujii
3,613,954 A	10/1971	Bayne	4,204,645 A	5/1980	Hopp
3,647,143 A	3/1972	Gauthier et al.	4,232,828 A	11/1980	Shelly, Jr.
3,648,932 A	3/1972	Ewald et al.	4,238,264 A	12/1980	Pelton
3,653,558 A	4/1972	Shay	4,240,940 A	12/1980	Vasishth et al.
3,680,789 A	8/1972	Wagner	4,258,141 A	3/1981	Jarre et al.

US D787,326 S

4,275,172 A	6/1981	Barth et al.	5,100,055 A	3/1992	Rokitenetz et al.
4,293,353 A	10/1981	Pelton et al.	5,115,944 A	5/1992	Nikolich
4,308,973 A	1/1982	Irland	5,126,086 A	6/1992	Stoffel
4,310,108 A	1/1982	Motoyama et al.	5,150,880 A	9/1992	Austin, Jr. et al.
4,322,020 A	3/1982	Stone	5,169,037 A	12/1992	Davies et al.
4,346,743 A	8/1982	Miller	5,182,316 A	1/1993	DeVoe et al.
4,354,638 A	10/1982	Weinstein	5,185,197 A	2/1993	Nixon
4,358,388 A	11/1982	Daniel et al.	5,188,263 A	2/1993	Woods
4,364,521 A	12/1982	Stankowitz	5,188,295 A	2/1993	Stern et al.
4,370,930 A	2/1983	Strasser et al.	5,211,317 A	5/1993	Diamond et al.
4,372,475 A	2/1983	Goforth et al.	5,219,609 A	6/1993	Owens
4,401,271 A	8/1983	Hansen	5,232,161 A	8/1993	Clemmons
4,401,272 A	8/1983	Merton et al.	5,250,599 A	10/1993	Swartz
4,411,387 A	10/1983	Stern et al.	5,255,846 A	10/1993	Ortega
4,417,674 A	11/1983	Giuffredi	5,277,336 A	1/1994	Youel
4,434,939 A	3/1984	Stankowitz	5,288,024 A	2/1994	Vitale
4,438,221 A	3/1984	Fracalossi et al.	5,297,704 A	3/1994	Stollmeyer
4,438,884 A	3/1984	O'Brien et al.	5,307,964 A	5/1994	Toth
4,442,959 A	4/1984	Del Bon et al.	5,310,095 A	5/1994	Stern et al.
4,460,719 A	7/1984	Danville	5,312,888 A	5/1994	Nafziger et al.
4,482,662 A	11/1984	Rapaport et al.	5,314,097 A	5/1994	Smrt et al.
D277,072 S *	1/1985	Czech D9/447	5,323,963 A	6/1994	Ballu
4,496,081 A	1/1985	Farrey	5,341,970 A	8/1994	Woods
4,546,905 A	10/1985	Nandagiri et al.	5,342,597 A	8/1994	Tunison, III
4,595,127 A	6/1986	Stoody	5,360,127 A	11/1994	Barriac et al.
4,609,608 A	9/1986	Sole	5,368,207 A	11/1994	Cruysberghs
4,620,669 A	11/1986	Polk	5,374,434 A	12/1994	Clapp et al.
4,641,765 A	2/1987	Diamond	5,405,051 A	4/1995	Miskell
4,674,903 A	6/1987	Chen	5,409,148 A	4/1995	Stern et al.
4,680,173 A	7/1987	Burger	5,415,351 A	5/1995	Otto et al.
4,683,246 A	7/1987	Davis et al.	5,417,357 A	5/1995	Yquel
4,685,622 A	8/1987	Shimohira et al.	D358,989 S	6/1995	Woods
4,702,400 A	10/1987	Corbett	5,421,519 A	6/1995	Woods
4,706,888 A	11/1987	Dobbs	5,425,824 A	6/1995	Marwick
4,728,007 A	3/1988	Samuelson et al.	5,443,211 A	8/1995	Young et al.
D295,725 S	5/1988	Shioda	5,450,983 A	9/1995	Stern et al.
4,744,495 A	5/1988	Warby	5,467,902 A	11/1995	Yquel
4,744,516 A	5/1988	Peterson et al.	5,476,879 A	12/1995	Woods et al.
4,761,312 A	8/1988	Koshi et al.	5,489,048 A	2/1996	Stern et al.
4,792,062 A	12/1988	Goncalves	5,498,282 A	3/1996	Miller et al.
4,793,162 A	12/1988	Emmons	5,501,375 A	3/1996	Nilson
4,804,144 A	2/1989	Denman	5,505,344 A	4/1996	Woods
4,815,414 A	3/1989	Duffy et al.	5,523,798 A	6/1996	Hagino et al.
4,819,838 A	4/1989	Hart, Jr.	5,524,798 A	6/1996	Stern et al.
4,830,224 A	5/1989	Brisson	5,544,783 A	8/1996	Conigliaro
4,839,393 A	6/1989	Buchanan et al.	5,548,010 A	8/1996	Franer
4,850,387 A	7/1989	Bassill	5,549,228 A	8/1996	Brown
4,854,482 A	8/1989	Bergner	5,558,247 A	9/1996	Caso
4,863,104 A	9/1989	Masterson	5,562,235 A	10/1996	Cruysberghs
4,870,805 A	10/1989	Morane	D375,890 S	11/1996	Takai
4,878,599 A	11/1989	Greenway	5,570,813 A	11/1996	Clark, II
4,887,651 A	12/1989	Santiago	5,573,137 A	11/1996	Pauls
4,893,730 A	1/1990	Bolduc	5,577,851 A	11/1996	Koptis
4,896,832 A	1/1990	Howlett	5,583,178 A	12/1996	Oxman et al.
D307,649 S	5/1990	Henry	5,597,095 A	1/1997	Ferrara, Jr.
RE33,235 E	6/1990	Corsette	5,615,804 A	4/1997	Brown
4,940,171 A	7/1990	Gilroy	5,638,990 A	6/1997	Kastberg
4,948,054 A	8/1990	Mills	5,639,026 A	6/1997	Woods
4,949,871 A	8/1990	Flanner	5,641,095 A	6/1997	de Laforcade
4,951,876 A	8/1990	Mills	5,645,198 A	7/1997	Stern et al.
4,953,759 A	9/1990	Schmidt	5,655,691 A	8/1997	Stern et al.
4,954,544 A	9/1990	Chandaria	5,695,788 A	12/1997	Woods
4,955,545 A	9/1990	Stern et al.	5,715,975 A	2/1998	Stern et al.
4,961,537 A	10/1990	Stern	5,727,736 A	3/1998	Tryon
4,969,577 A	11/1990	Werdning	5,752,631 A	5/1998	Yabuno et al.
4,969,579 A	11/1990	Behar	5,775,432 A	7/1998	Burns et al.
4,988,017 A	1/1991	Schrader et al.	5,788,129 A	8/1998	Markos
4,989,787 A	2/1991	Nikkel et al.	5,792,465 A	8/1998	Hagarty
4,991,750 A	2/1991	Moral	5,799,879 A	9/1998	Ottl et al.
5,007,556 A	4/1991	Lover	5,865,351 A	2/1999	De Laforcade
5,009,390 A	4/1991	McAuliffe, Jr. et al.	5,868,286 A	2/1999	Mascitelli
5,037,011 A	8/1991	Woods	5,887,756 A	3/1999	Brown
5,038,964 A	8/1991	Bouix	5,894,964 A	4/1999	Barnes et al.
5,039,017 A	8/1991	Howe	D409,487 S	5/1999	Wadsworth et al.
5,052,585 A	10/1991	Bolduc	D409,917 S	5/1999	Wadsworth et al.
5,059,187 A	10/1991	Sperry et al.	D409,918 S	5/1999	Wadsworth et al.
5,065,900 A	11/1991	Scheindel	5,915,598 A	6/1999	Yazawa et al.
5,069,390 A	12/1991	Stern et al.	5,921,446 A	7/1999	Stern
5,083,685 A	1/1992	Amemiya et al.	5,934,518 A	8/1999	Stern et al.

US D787,326 S

5,941,462 A	8/1999	Sandor	6,607,106 B2	8/2003	Henry et al.	
5,957,333 A	9/1999	Losenno et al.	6,613,186 B2	9/2003	Johnson	
5,975,356 A	11/1999	Yquel et al.	6,615,827 B2	9/2003	Greenwood et al.	
5,979,797 A	11/1999	Castellano	6,637,627 B1	10/2003	Liljeqvist	
5,988,575 A	11/1999	Lesko	6,641,005 B1	11/2003	Stern et al.	
5,988,923 A	11/1999	Arai	6,641,864 B2	11/2003	Woods	
6,000,583 A	12/1999	Stern et al.	6,652,704 B2	11/2003	Green	
6,027,042 A	2/2000	Smith	6,659,312 B1	12/2003	Stern et al.	
6,032,830 A	3/2000	Brown	6,666,352 B1	12/2003	Woods	
6,039,306 A	3/2000	Pericard et al.	6,688,492 B2	2/2004	Jaworski et al.	
6,062,494 A	5/2000	Mills	6,712,238 B1	3/2004	Mills	
6,070,770 A	6/2000	Tada et al.	6,726,066 B2	4/2004	Woods	
6,092,698 A	7/2000	Bayer	6,736,288 B1	5/2004	Green	
6,095,377 A	8/2000	Sweeton et al.	6,758,373 B2	7/2004	Jackson et al.	
6,095,435 A	8/2000	Greer, Jr. et al.	6,797,051 B2	9/2004	Woods	
6,112,945 A	9/2000	Woods	6,802,461 B2	10/2004	Schneider	
6,113,070 A	9/2000	Holzboog	6,831,110 B2	12/2004	Ingold et al.	
6,116,473 A	9/2000	Stern et al.	6,832,704 B2	12/2004	Smith	
6,126,090 A	10/2000	Wadsworth et al.	6,837,396 B2	1/2005	Jaworski et al.	
6,129,247 A	10/2000	Thomas et al.	6,843,392 B1	1/2005	Walker	
6,131,777 A	10/2000	Warby	D501,538 S	2/2005	Zeng	
6,131,820 A	10/2000	Dodd	D501,914 S	2/2005	Chen	
6,139,821 A	10/2000	Fuerst et al.	6,848,601 B2	2/2005	Greer, Jr.	
6,152,335 A	11/2000	Stern et al.	6,851,575 B2	2/2005	van't Hoff	
6,161,735 A	12/2000	Uchiyama et al.	D502,533 S	3/2005	Chen	
6,168,093 B1	1/2001	Greer, Jr. et al.	6,880,733 B2	4/2005	Park	
6,170,717 B1	1/2001	Di Giovanni et al.	6,883,688 B1	4/2005	Stern et al.	
D438,111 S	2/2001	Woods	6,894,095 B2	5/2005	Russo et al.	
D438,786 S	3/2001	Ghali	6,905,050 B1	6/2005	Stern et al.	
6,225,393 B1	5/2001	Woods	6,910,608 B2	6/2005	Greer, Jr. et al.	
6,227,411 B1	5/2001	Good	D507,493 S *	7/2005	Nelson	D9/685
6,254,015 B1	7/2001	Abplanalp	6,913,407 B2	7/2005	Greer et al.	
6,257,503 B1	7/2001	Baudin	6,926,178 B1	8/2005	Anderson	
6,261,631 B1	7/2001	Lomasney et al.	6,929,154 B2	8/2005	Grey et al.	
6,265,459 B1	7/2001	Mahoney et al.	6,932,244 B2	8/2005	Meshberg	
6,276,570 B1	8/2001	Stern et al.	6,966,467 B2	11/2005	Di Giovanni et al.	
6,283,171 B1	9/2001	Blake	D512,309 S	12/2005	Geier	
6,284,077 B1	9/2001	Lucas et al.	6,971,353 B2	12/2005	Heinze et al.	
6,290,104 B1	9/2001	Bougamont et al.	6,971,553 B2	12/2005	Brennan et al.	
6,291,536 B1	9/2001	Taylor	6,978,916 B2	12/2005	Smith	
6,296,155 B1	10/2001	Smith	6,978,947 B2	12/2005	Jin	
6,296,156 B1	10/2001	Lasserre et al.	6,981,616 B2	1/2006	Loghman-Adham et al.	
6,299,679 B1	10/2001	Montoya	7,014,073 B1	3/2006	Stern et al.	
6,299,686 B1	10/2001	Mills	7,014,127 B2	3/2006	Valpey, III et al.	
6,315,152 B1	11/2001	Kalisz	7,036,685 B1	5/2006	Green	
6,325,256 B1	12/2001	Liljeqvist et al.	7,045,008 B2	5/2006	Langford	
6,328,185 B1	12/2001	Stern et al.	7,059,497 B2	6/2006	Woods	
6,328,197 B1	12/2001	Gapihan	7,059,546 B2	6/2006	Ogata et al.	
6,333,365 B1	12/2001	Lucas et al.	7,063,236 B2	6/2006	Greer, Jr. et al.	
6,334,727 B1	1/2002	Gueret	7,104,424 B2	9/2006	Kolanus	
6,352,184 B1	3/2002	Stern et al.	7,104,427 B2	9/2006	Pericard et al.	
6,362,302 B1	3/2002	Boddie	7,121,434 B1	10/2006	Caruso	
6,375,036 B1	4/2002	Woods	7,163,962 B2	1/2007	Woods	
6,382,474 B1	5/2002	Woods et al.	D537,359 S *	2/2007	Butler	D9/685
6,386,402 B1	5/2002	Woods	7,182,227 B2	2/2007	Poile et al.	
6,394,321 B1	5/2002	Bayer	D538,650 S *	3/2007	Paas	D9/448
6,394,364 B1	5/2002	Abplanalp	D539,142 S *	3/2007	Butler	D9/448
6,395,794 B2	5/2002	Lucas et al.	7,189,022 B1	3/2007	Greer, Jr. et al.	
6,398,082 B2	6/2002	Clark et al.	7,192,985 B2	3/2007	Woods	
6,399,687 B2	6/2002	Woods	7,204,393 B2	4/2007	Strand	
6,408,492 B1	6/2002	Sparks et al.	7,226,001 B1	6/2007	Stern et al.	
6,412,657 B2	7/2002	Riley et al.	7,226,232 B2	6/2007	Greer, Jr. et al.	
6,414,044 B2	7/2002	Taylor	7,232,047 B2	6/2007	Greer, Jr. et al.	
6,415,964 B2	7/2002	Woods	7,237,697 B2	7/2007	Dunne	
6,439,430 B1	8/2002	Gilroy, Sr. et al.	7,240,857 B1	7/2007	Stern et al.	
6,446,842 B2	9/2002	Stern et al.	7,249,692 B2	7/2007	Walters et al.	
D464,395 S	10/2002	Huang	7,261,225 B2	8/2007	Rueschhoff et al.	
6,474,513 B2	11/2002	Burt	7,267,248 B2	9/2007	Yerby et al.	
6,478,198 B2	11/2002	Haroian	7,278,590 B1	10/2007	Greer, Jr. et al.	
6,478,561 B2	11/2002	Braun et al.	7,303,152 B2	12/2007	Woods	
6,482,392 B1	11/2002	Zhou et al.	7,307,053 B2	12/2007	Tasz et al.	
D468,980 S	1/2003	Woods	7,337,985 B1	3/2008	Greer, Jr. et al.	
6,510,969 B2	1/2003	Di Giovanni et al.	7,341,169 B2	3/2008	Bayer	
6,520,377 B2	2/2003	Yquel	7,350,676 B2	4/2008	Di Giovanni et al.	
6,531,528 B1	3/2003	Kurp	D569,723 S *	5/2008	Sellick	D9/448
6,536,633 B2	3/2003	Stern et al.	7,374,068 B2	5/2008	Greer, Jr.	
6,581,807 B1	6/2003	Mekata	7,383,968 B2	6/2008	Greer, Jr. et al.	
6,588,628 B2	7/2003	Abplanalp et al.	7,383,970 B2	6/2008	Anderson	
6,595,393 B1	7/2003	Loghman-Adham et al.	D580,761 S *	11/2008	Sweeton	D9/448

US D787,326 S

7,445,166	B2	11/2008	Williams		8,251,255	B1	8/2012	Greer, Jr. et al.	
7,448,517	B2	11/2008	Shieh et al.		8,267,286	B2	9/2012	Smrt et al.	
D581,789	S *	12/2008	Ames	D9/448	8,276,832	B2	10/2012	Nelson et al.	
D582,272	S *	12/2008	Cichy	D9/448	8,281,958	B2	10/2012	Mathews et al.	
D583,668	S *	12/2008	Sweeton	D9/448	8,286,839	B2	10/2012	Jasper	
7,481,338	B1	1/2009	Stern et al.		D671,422	S *	11/2012	Thurin	D9/689
7,487,891	B2	2/2009	Yerby et al.		8,313,011	B2	11/2012	Greer, Jr. et al.	
7,487,893	B1	2/2009	Greer, Jr. et al.		8,317,065	B2	11/2012	Stern et al.	
7,494,075	B2	2/2009	Schneider		8,328,053	B2	12/2012	Bargo	
7,500,621	B2	3/2009	Tryon		8,328,120	B2	12/2012	Vanblacre et al.	
7,510,102	B2	3/2009	Schmitt		8,333,304	B1	12/2012	Haage	
D590,712	S *	4/2009	Sweeton	D9/448	8,336,742	B2	12/2012	Greer, Jr. et al.	
D591,612	S *	5/2009	Ames	D9/685	8,342,421	B2	1/2013	Greer, Jr. et al.	
D595,575	S *	7/2009	Cichy	D9/448	8,344,056	B1	1/2013	Tait et al.	
7,556,841	B2	7/2009	Kimball et al.		8,353,465	B2	1/2013	Tryon et al.	
D600,119	S *	9/2009	Sweeton	D9/448	8,356,734	B2	1/2013	Oshimo et al.	
7,588,171	B2	9/2009	Reedy et al.		8,360,280	B2	1/2013	Tournier	
7,597,274	B1	10/2009	Stern et al.		8,371,481	B2	2/2013	Kopp	
7,600,659	B1	10/2009	Greer, Jr. et al.		8,393,554	B2	3/2013	Yamamoto et al.	
7,624,932	B1	12/2009	Greer, Jr. et al.		8,420,705	B2	4/2013	Greer, Jr.	
7,631,785	B2	12/2009	Paas et al.		8,444,026	B2	5/2013	Adams et al.	
7,641,079	B2	1/2010	Lott et al.		8,469,292	B1	6/2013	Hanson et al.	
7,673,816	B1	3/2010	Stern et al.		8,505,786	B2	8/2013	Stern et al.	
7,677,420	B1	3/2010	Greer, Jr. et al.		D691,488	S *	10/2013	Broen	D9/682
7,699,190	B2	4/2010	Hygema		8,551,572	B1	10/2013	Tait et al.	
D615,833	S *	5/2010	Elmelund	D8/14.1	8,561,840	B2	10/2013	Greer, Jr. et al.	
7,721,920	B2	5/2010	Ruiz De Gopegui et al.		8,573,451	B2	11/2013	Tryon	
7,744,299	B1	6/2010	Greer, Jr. et al.		8,580,349	B1	11/2013	Kordosh et al.	
7,748,572	B2	7/2010	Althoff et al.		8,584,898	B2	11/2013	Greer, Jr. et al.	
7,757,905	B2	7/2010	Strand et al.		8,622,255	B2	1/2014	Greer, Jr.	
7,766,196	B2	8/2010	Sugano et al.		D698,660	S *	2/2014	Maas	D9/689
7,775,408	B2	8/2010	Yamamoto et al.		8,647,006	B2	2/2014	Greer, Jr. et al.	
7,784,647	B2	8/2010	Tourigny		8,701,944	B2	4/2014	Tryon	
7,784,649	B2	8/2010	Greer, Jr.		8,784,942	B2	7/2014	Tait et al.	
7,789,278	B2	9/2010	Ruiz de Gopegui et al.		D710,697	S *	8/2014	Lind	D9/448
7,845,523	B1	12/2010	Greer, Jr. et al.		8,820,656	B2	9/2014	Tryon et al.	
7,854,356	B2	12/2010	Eberhardt		8,840,038	B2	9/2014	Lehr	
7,861,894	B2	1/2011	Walters et al.		8,844,765	B2	9/2014	Tryon	
7,886,995	B2	2/2011	Togashi		8,883,902	B2	11/2014	Tait et al.	
7,891,529	B2	2/2011	Paas et al.		8,887,953	B2	11/2014	Greer, Jr. et al.	
7,913,877	B2	3/2011	Neuhalfen		D718,624	S *	12/2014	Hanson	D9/448
7,922,041	B2	4/2011	Gurrisi et al.		D746,135	S *	12/2015	Lind	D9/448
7,926,741	B2	4/2011	Laidler et al.		2001/0002676	A1	6/2001	Woods	
7,947,753	B2	5/2011	Greer, Jr.		2002/0003147	A1	1/2002	Corba	
D639,160	S *	6/2011	Jug	D9/448	2002/0100769	A1	8/2002	McKune	
7,971,800	B2	7/2011	Combs et al.		2002/0119256	A1	8/2002	Woods	
7,980,487	B2	7/2011	Mirazita et al.		2003/0102328	A1	6/2003	Abplanalp et al.	
7,984,827	B2	7/2011	Hygema		2003/0134973	A1	7/2003	Chen et al.	
7,984,834	B2	7/2011	McBroom et al.		2003/0183651	A1	10/2003	Greer, Jr.	
7,997,511	B2	8/2011	Reynolds et al.		2003/0205580	A1	11/2003	Yahav	
8,006,868	B2	8/2011	Geiberger et al.		2004/0012622	A1	1/2004	Russo et al.	
8,016,163	B2	9/2011	Behar et al.		2004/0099697	A1	5/2004	Woods	
8,025,189	B2	9/2011	Salameh		2004/0141797	A1	7/2004	Garabedian et al.	
8,028,861	B2	10/2011	Brouwer		2004/0154264	A1	8/2004	Colbert	
8,028,864	B2	10/2011	Stern et al.		2004/0157960	A1	8/2004	Rowe	
8,033,432	B2	10/2011	Pardonge et al.		2004/0195277	A1	10/2004	Woods	
8,033,484	B2	10/2011	Tryon et al.		2005/0121474	A1	6/2005	Lasserre et al.	
8,038,077	B1	10/2011	Greer, Jr. et al.		2005/0236436	A1	10/2005	Woods	
8,042,713	B2	10/2011	Greer, Jr. et al.		2005/0256257	A1	11/2005	Betremieux et al.	
8,070,017	B2	12/2011	Green		2006/0049205	A1	3/2006	Green	
8,074,847	B2	12/2011	Smith		2006/0180616	A1	8/2006	Woods	
8,074,848	B2	12/2011	Pittl et al.		2006/0219808	A1	10/2006	Woods	
8,083,159	B2	12/2011	Leuliet et al.		2006/0219811	A1	10/2006	Woods	
8,087,548	B2	1/2012	Kimball		2006/0273207	A1	12/2006	Woods	
8,087,552	B2	1/2012	Fazekas et al.		2007/0117916	A1	5/2007	Anderson et al.	
8,128,008	B2	3/2012	Chevalier		2007/0119984	A1	5/2007	Woods	
8,132,697	B2	3/2012	Finlay et al.		2007/0125879	A1	6/2007	Khamenian	
8,146,782	B2	4/2012	Gross et al.		2007/0142260	A1	6/2007	Tasz et al.	
8,157,135	B2	4/2012	Stern et al.		2007/0155892	A1	7/2007	Gharapetian et al.	
8,172,113	B2	5/2012	Greer, Jr.		2007/0178243	A1	8/2007	Houck et al.	
8,187,574	B2	5/2012	Mekata et al.		2007/0194040	A1	8/2007	Tasz et al.	
D661,580	S	6/2012	Takizawa et al.		2007/0219310	A1	9/2007	Woods	
8,191,739	B1	6/2012	Cash et al.		2007/0228086	A1	10/2007	Delande et al.	
8,196,783	B2	6/2012	Krzecki		2007/0260011	A1	11/2007	Woods	
8,201,757	B2	6/2012	Suzuki		2007/0272765	A1	11/2007	Kwasny	
8,215,862	B2	7/2012	Greer, Jr. et al.		2007/0272768	A1	11/2007	Williams et al.	
8,217,091	B2	7/2012	Vijayakumar		2008/0008678	A1	1/2008	Wyers	
8,221,019	B2	7/2012	Greer, Jr. et al.		2008/0029551	A1	2/2008	Lombardi	
8,240,523	B2	8/2012	Goulet		2008/0033099	A1	2/2008	Bosway	

2008/0041887	A1	2/2008	Scheindel	CA	1210371	8/1986
2008/0229535	A1	9/2008	Walter	CA	2145129	9/1995
2009/0004468	A1	1/2009	Chen et al.	CA	2090185	10/1998
2009/0020621	A1	1/2009	Clark et al.	CA	2224042	6/1999
2010/0108716	A1	5/2010	Bilko	CA	2291599	6/2000
2010/0155432	A1	6/2010	Christianson	CA	2381994	2/2001
2010/0322892	A1	12/2010	Burke	CA	2327903	6/2001
2011/0021675	A1	1/2011	Shigemori et al.	CA	2065534	8/2003
2011/0101025	A1	5/2011	Walters et al.	CA	2448794	5/2004
2011/0121037	A1*	5/2011	Kakuta	CA	2504509	10/2005
			B05B 11/0067	CA	2504513	10/2005
			222/320	CA	2533964	7/2006
2011/0127300	A1	6/2011	Ghavami-Nasr et al.	CH	680849	11/1992
2011/0210141	A1	9/2011	Maas et al.	CN	302618375	* 9/2007
2011/0210184	A1	9/2011	Maas et al.	DE	210449	5/1909
2011/0215119	A1	9/2011	McBroom	DE	250831	9/1912
2011/0218096	A1	9/2011	Hatanaka et al.	DE	634230	8/1936
2011/0220685	A1	9/2011	Lind et al.	DE	1047686	10/1957
2011/0240682	A1	10/2011	Miyamoto et al.	DE	1926796	3/1970
2011/0240771	A1	10/2011	Legeza	DE	3527922	8/1985
2011/0253749	A1	10/2011	Hygema	DE	3808438	4/1989
2011/0257302	A1	10/2011	Terrenoire et al.	DE	3806991	9/1989
2011/0266310	A1	11/2011	Tomkins et al.	EP	2130788	12/2009
2012/0000930	A1	1/2012	Barbieri	FR	463476	2/1914
2012/0000931	A1	1/2012	Cabiri et al.	FR	84727	9/1965
2012/0006858	A1	1/2012	Rovelli	FR	1586067	12/1969
2012/0006859	A1	1/2012	Wilkinson et al.	FR	2336186	7/1977
2012/0032000	A1	2/2012	Brunk et al.	FR	2659847	9/1991
2012/0043353	A1	2/2012	Davideit et al.	FR	2792296	10/2000
2012/0048959	A1	3/2012	Maas et al.	GB	470488	11/1935
2012/0064249	A1	3/2012	Greer, Jr. et al.	GB	491396	9/1938
2012/0097713	A1	4/2012	MacKinnon et al.	GB	494134	10/1938
2012/0132670	A1	5/2012	Finlay et al.	GB	508734	7/1939
2012/0168460	A1	7/2012	Tolstykh	GB	534349	3/1941
2012/0168463	A1	7/2012	Hanai et al.	GB	675664	7/1952
2012/0181300	A1	7/2012	Maxa et al.	GB	726455	3/1955
2012/0211513	A1	8/2012	Alfaro et al.	GB	867713	5/1961
2012/0228336	A1	9/2012	Davideit et al.	GB	970766	9/1964
2012/0234947	A1	9/2012	Takahashi	GB	977860	12/1964
2012/0241457	A1	9/2012	Hallman et al.	GB	1144385	3/1969
2012/0261439	A1	10/2012	Dennis et al.	GB	1536312	12/1978
2012/0312896	A1	12/2012	Thurin et al.	GB	2418959	4/2006
2012/0318830	A1	12/2012	Lim	JP	461392	1/1971
2013/0008981	A1	1/2013	Bloc et al.	JP	55142073	11/1980
2013/0022747	A1	1/2013	Greer, Jr. et al.	JP	8332414	12/1996
2013/0026252	A1	1/2013	Hanson et al.	MX	025894	* 9/2008
2013/0026253	A1	1/2013	Hanson et al.	NL	8000344	8/1981
2013/0037580	A1	2/2013	Armstrong et al.	WO	8904796	6/1989
2013/0037582	A1	2/2013	Andersen et al.	WO	9418094	8/1994
2013/0102696	A1	4/2013	Greer, Jr. et al.	WO	2005087617	9/2005
2013/0112766	A1	5/2013	Maas et al.	WO	2005108240	11/2005
2013/0122200	A1	5/2013	Greer, Jr. et al.	WO	2006090229	8/2006
2013/0230655	A1	9/2013	Greer, Jr.	WO	2008060157	5/2008
2014/0050853	A1	2/2014	Greer, Jr. et al.	WO	2013019683	2/2013
2014/0061335	A1	3/2014	Tryon	WO	2014144671	9/2014
2014/0072714	A1	3/2014	Kordosh et al.	WO	2014165237	10/2014
2014/0079882	A1	3/2014	Greer, Jr. et al.			
2014/0113076	A1	4/2014	Greer, Jr. et al.			
2014/0120260	A1	5/2014	Greer, Jr.			
2014/0162023	A1	6/2014	Greer, Jr. et al.			
2014/0248428	A1	9/2014	Tryon			
2014/0249256	A1	9/2014	Kordosh			
2014/0263417	A1	9/2014	Hanson et al.			
2014/0272124	A1	9/2014	Kordosh et al.			
2014/0272140	A1*	9/2014	Hanson			
			B65D 83/752			
			427/256			
2014/0335278	A1	11/2014	Tait et al.			
2014/0367410	A1	12/2014	Tryon et al.			
2015/0028053	A1	1/2015	Tryon			
2015/0050425	A1*	2/2015	Hanson			
			B65D 83/202			
			427/421.1			
2016/0106241	A1*	4/2016	Wong			
			A47G 19/2272			
			220/254.5			

FOREIGN PATENT DOCUMENTS

CA	770467	10/1967
CA	976125	10/1975
CA	1191493	8/1985

OTHER PUBLICATIONS

Pro Grade Orange Peel Ceiling Texture: Announced Jul. 2013 [online], site visited Jun. 9, 2016. Available from Internet URL: http://www.homaxproducts.com/Pro-Grade-Orange-Peel-Ceiling-Texture-Water-based-20-oz.*

Homax Products, Inc., "Easy Touch Spray Texture Brochure", Mar. 1992, 1 page.

Newman-Green, Inc., "Aerosol Valves, Sprayheads & Accessories Catalog", Apr. 1, 1992, pp. 14, 20, and 22.

ASTM, "Standard Test Method for Conducting Cyclic Potentiodynamic Polarization Measurements for Localized Corrosion Susceptibility of Iron-Nickel-, or Cobalt-Based Alloys," 1993, 5 pages.

Tait, "An Introduction to Electrochemical Corrosion Testing for Practicing Engineers and Scientists," 1994, 17 pages.

Saint-Gobain Calmar; "Mixer HP Trigger Sprayer Brochure", Dec. 2001; 2 pages.

Chinese document disclosing a trigger spray assembly for a spray bottle; 2004, 1 page.

Chinese document disclosing a trigger spray assembly for a spray bottle; Jun. 4, 2004; 1 page.

Chadwick, "Controlling Particle Size in Self-Pressurized Aerosol Packages," Jul./Aug. 2004, 3 pages, vol. 102 No. 7/8.

Chinese document disclosing a trigger spray assembly for a spray bottle; Jun. 5, 2004; 1 page.

Glidden, "Glidden Ceiling Paint with EZ Track Technology, Frequently Asked Questions about EZ Track", Website: <http://www.gliddeneztrack.com/home/faq.jsp>, 2004, 1 page.

Glidden, "New Glidden Ceiling Paint Makes Tracks Across the Country", Website: <http://www.glidden.com/mediazone/PressRelease5001990.jsp>, May 24, 2004, 1 page.

Glidden, "Ceiling Paint", Website: <http://www.glidden.com/products/getProducts.do?brandid=10>, 2005, 1 page.

Hazelton, "How to Refinish a Kitchen Table," Website: http://www.ronhazelton.com/projects/how_to_refinish_a_kitchen_table, Sep. 23, 2011, 5 pages.

Homax Products, Inc., "Pro Grade Wall Textures," Website: <http://orders.homaxproducts.com/Pro-Grade-Wall-Textures>, accessed online Nov. 11, 2013, 1 page.

Vila, "How to Refinish a Wood Table," Website: <http://www.bobvila.com/articles/2498-how-to-refinish-a-wood-table/>, Sep. 3, 2013, 11 pages.

* cited by examiner

Primary Examiner — Thomas Johannes

Assistant Examiner — Catherine Posthauer

(74) *Attorney, Agent, or Firm* — Michael R. Schrach

(57)

CLAIM

The new design for a cap with actuator, as shown and described herein.

DESCRIPTION

FIG. 1 is a front elevation view of a cap with actuator showing our new design;

FIG. 2 is a first side elevation view thereof;

FIG. 3 is a second side elevation view thereof;

FIG. 4 is a rear end elevation view thereof;

FIG. 5 is a top plan view thereof; and,

FIG. 6 is a bottom plan view thereof.

The evenly broken lines are shown for the purpose of illustrations of parts of the article that form no part of the claim. The dot-dash broken lines are shown for the purpose of illustrating environmental structure and form no part of the claim.

1 Claim, 3 Drawing Sheets

FIG. 1

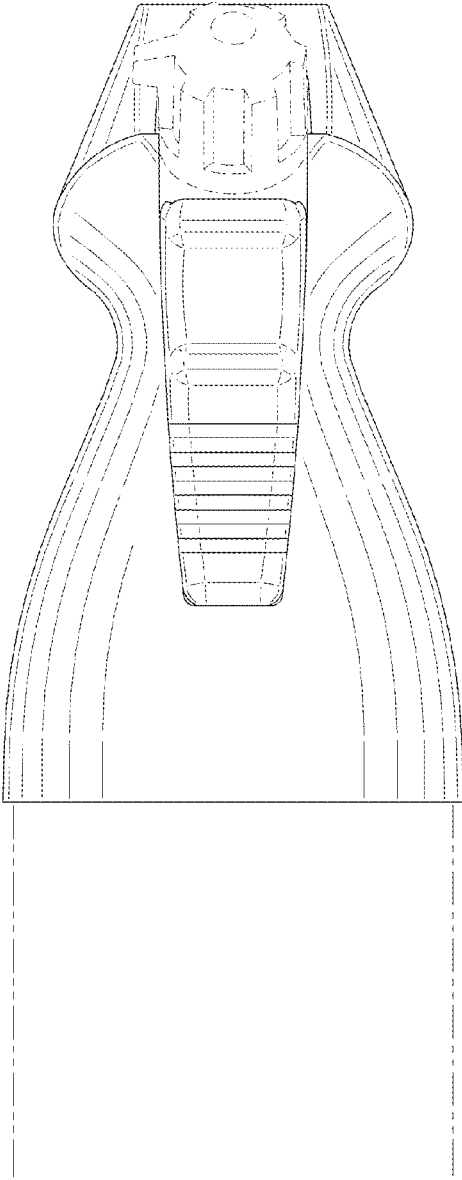

FIG. 2

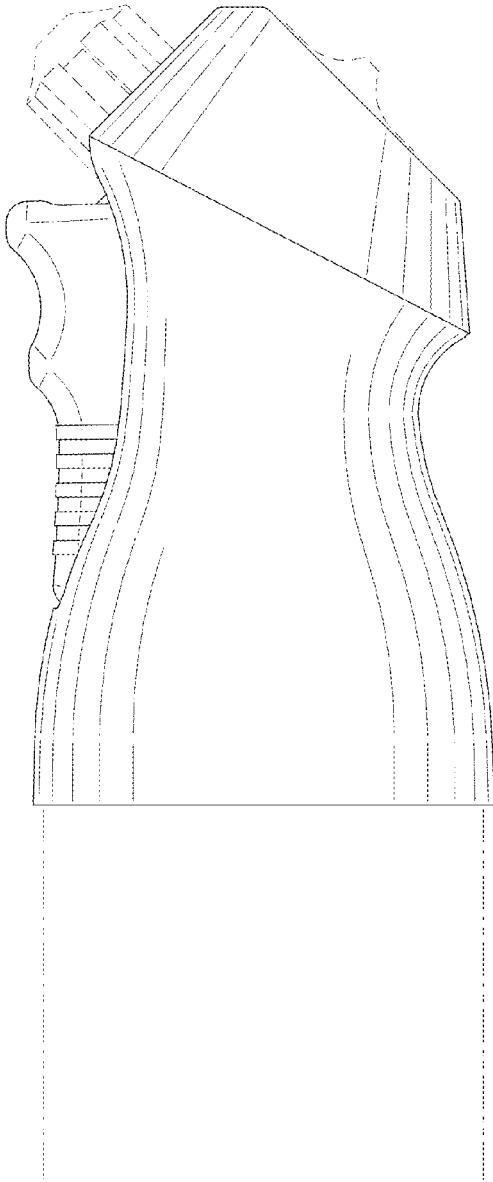

FIG. 3

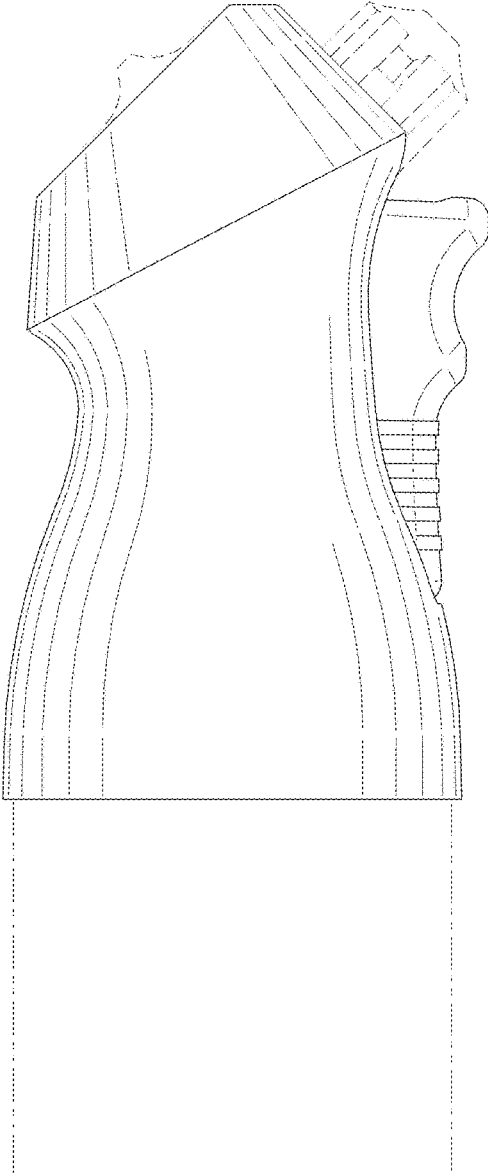

FIG. 4

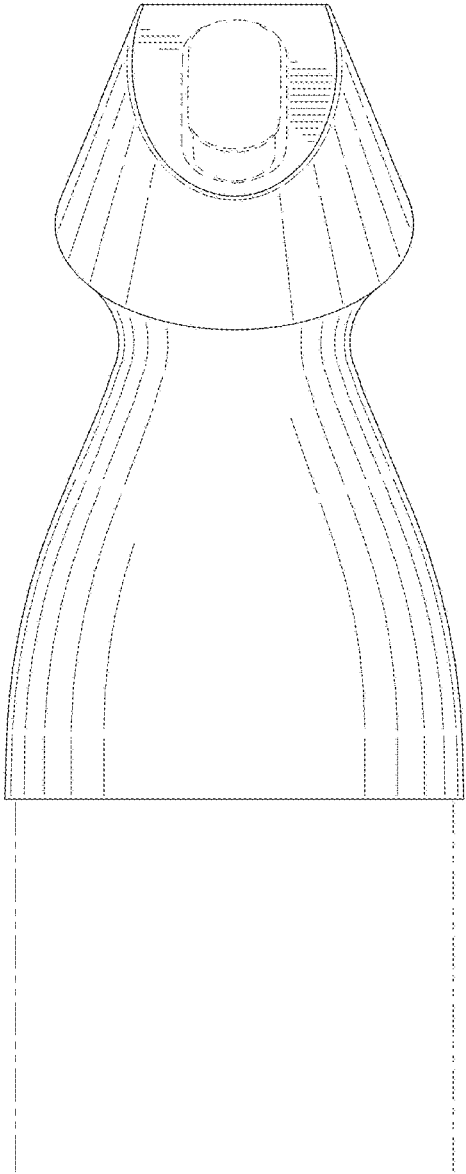

FIG. 5

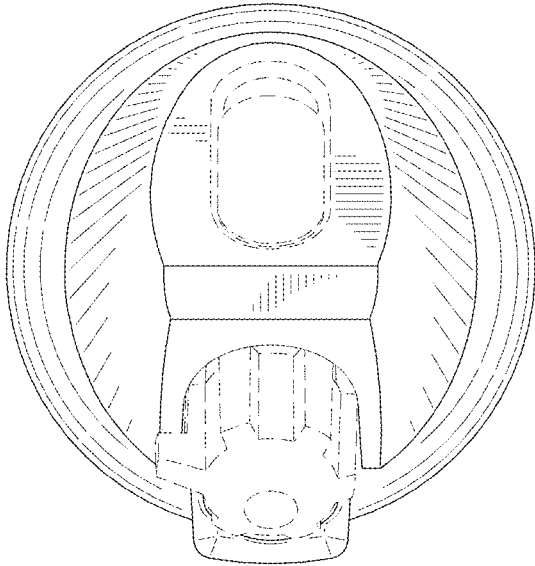

FIG. 6

