

Sept. 7, 1965

A. SIDELMAN

3,204,645

HAIR CURLER

Filed Aug. 20, 1962

3 Sheets-Sheet 1

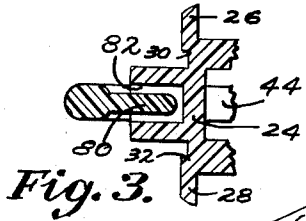

Fig. 1.

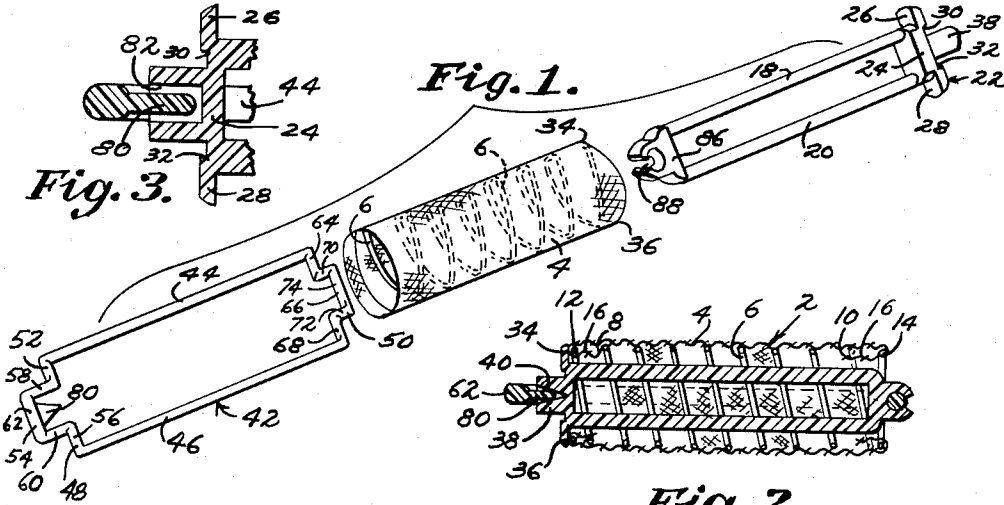

Fig. 2.

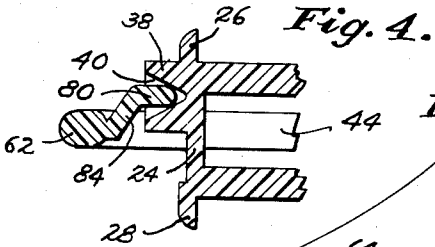

Fig. 5.

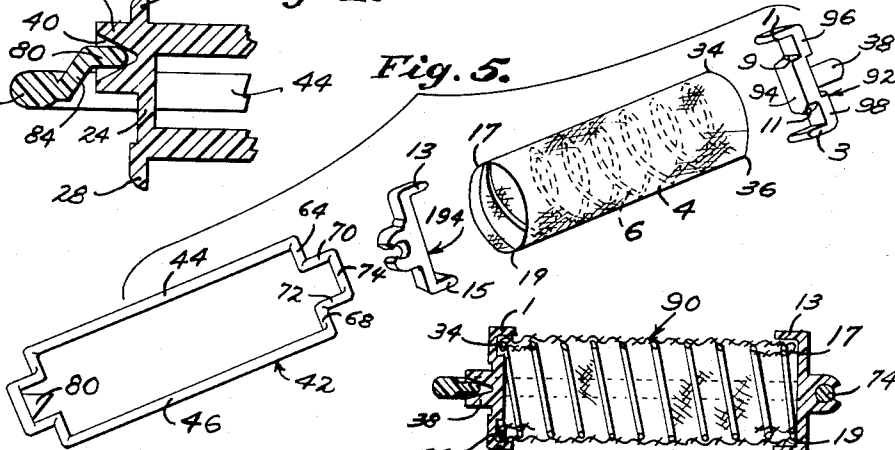

Fig. 6.

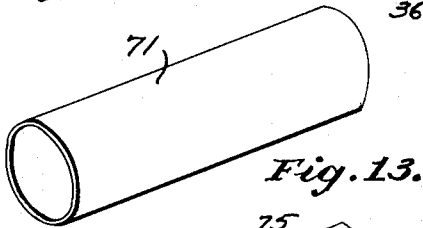

Fig. 13.

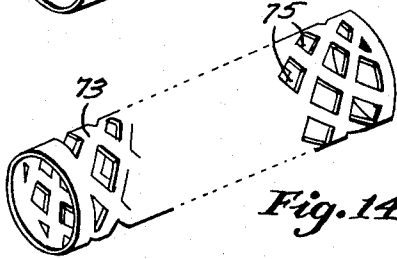

Fig. 14.

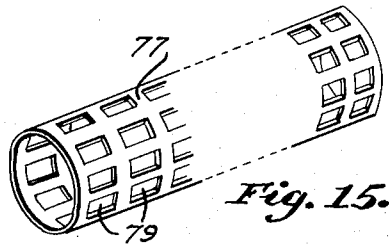

Fig. 15.

INVENTOR.
 Abraham Sidelman
 BY
 Norman F. Glass
 ATTORNEY

Sept. 7, 1965

A. SIDELMAN

3,204,645

HAIR CURLER

Filed Aug. 20, 1962

3 Sheets-Sheet 2

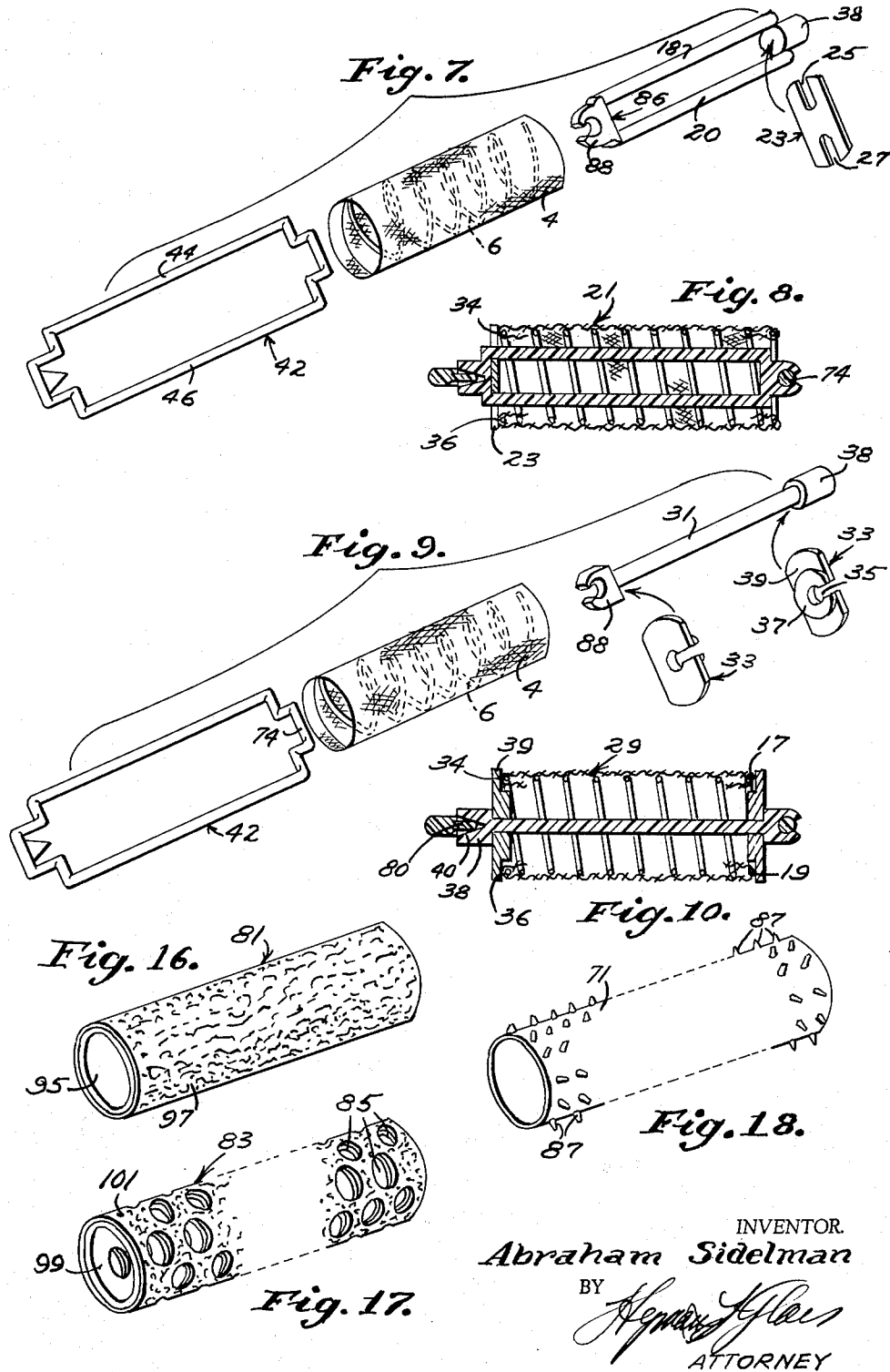

INVENTOR
Abraham Sidelman
BY *Henry J. Glass*
ATTORNEY

Sept. 7, 1965

A. SIDELMAN

3,204,645

HAIR CURLER

Filed Aug. 20, 1962

3 Sheets-Sheet 3

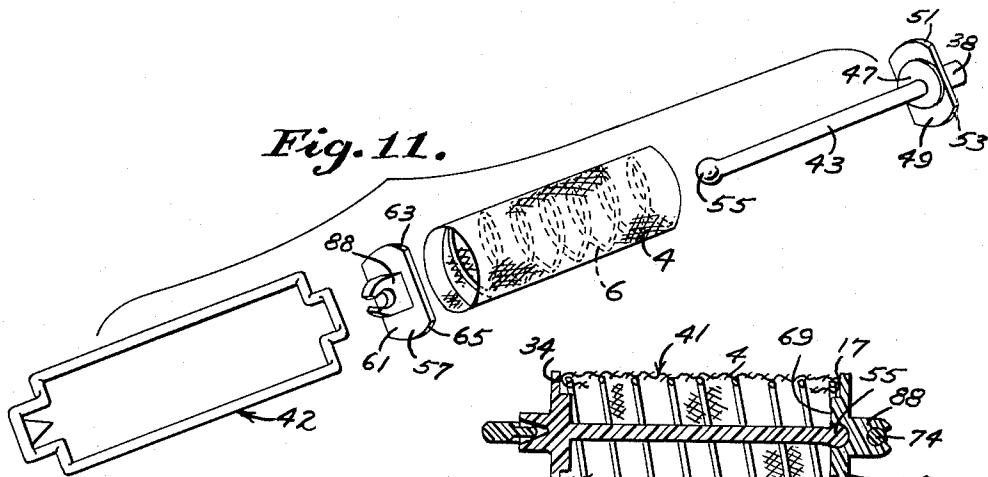

Fig. 11.

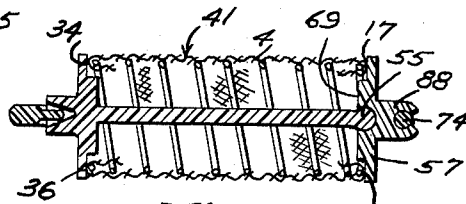

Fig. 12.

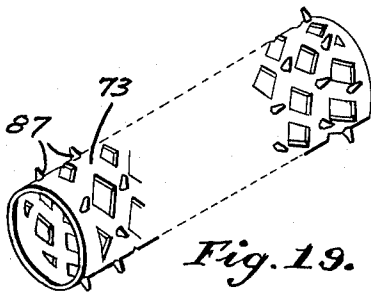

Fig. 19.

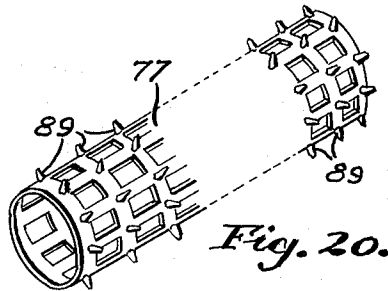

Fig. 20.

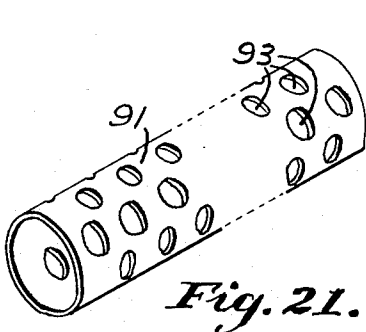

Fig. 21.

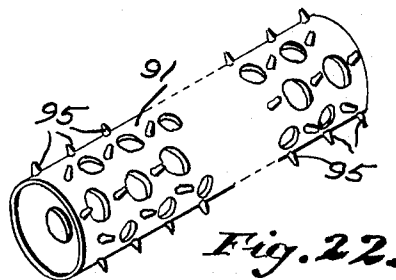

Fig. 22.

INVENTOR
Abraham Sidelman
BY
Hyman Glass
ATTORNEY

1

3,204,645

HAIR CURLER

Abraham Sidelman, 13 Doctor Frank Road,
Spring Valley, N.Y.

Filed Aug. 20, 1962, Ser. No. 217,821
27 Claims. (Cl. 132-41)

This application is a continuation-in-part of my application Serial No. 206,282, entitled Positive Locking Flexible Hair Curler, filed on June 29, 1962 and now abandoned, and is copending with my application Serial No. 217,820 entitled Bristle Brush Hair Curler, filed on the same day as this application.

This invention relates to hair curlers adapted to be positioned temporarily in the wearer's hair and to form a hair curl.

More particularly, this invention relates to hair curlers comprising, in combination, a cylindrical hollow tube, a frame including spaced-apart longitudinally extending sides and transversely extending members connecting said sides, means at one end of the hair curler for rotatably mounting said frame, an inwardly extending flexible tongue member integral with one of said transversely extending members, a member positioned with respect to one end of said tube and having recess means therein for receiving said tongue member, and means engaging said tube said positioned member for preventing substantial lateral movement of said positioned member with respect to said tube and for keeping said tube in position with respect to said frame member.

Hollow tubular, relatively thin-walled hair rollers, or mandrels, of braided or woven natural horsehair and artificial horsehair, perforated and imperforate molded or extruded thermoplastic resinous material such as polyethylene, polypropylene, polystyrene, cellulose acetate, polyurethane, and the like are well known. However, after the tuft, or plurality of strands, of hair is wound around such a roller, it is necessary to use a separate fastening member such as a hairpin or bobby pin for holding the so-wound hair in place about the roller.

Likewise, frame members, including spaced-apart longitudinally extending sides and transversely extending members connecting said sides, in combination with a roller other than one of those hereinbefore described are well known.

I have now discovered a hair curler comprising, in combination, (1) a hollow tubular, relatively thin-walled roller of the one of the types hereinbefore described and (2) a frame member, said hair curler being of such construction that said tubular roller, even though thin-walled, receives the hair tuft, or plurality of hair strands, therearound and then is easily locked in position by the frame without any substantial displacement of the tube between the respective planes of the longitudinally extending sides of the frame. This latter phenomenon, viz. no substantial displacement of the tube between said planes, is made possible by a plate-like member positioned at one end of the tube, or mandrel, and preferably overlapping and engaging diametrically opposed end portions of the tube. In engagement with, and preferably integral therewith, is a recessed member for receiving said tongue member. At the other end of the hair curler is a means for rotatably mounting the frame about the tube, or mandrel. Said plate-like member engages both the tube and the recessed member and thereby prevents substantial lateral movement of said recessed member with respect to said tube and keeps said tube from substantial displacement between the respective planes of the longitudinally extending sides of said frame. Thusly is the wearer of my hair curler able to fasten easily and simply the hair tuft wound on the tube without any substantial lateral displacement

2

of the tube between the respective planes of said longitudinally extending sides of the frame thereby to keep said tube in position with respect to the frame and to prevent substantial lateral movement of said recessed member with respect to said tube.

The tube of my hair curler is preferably cylindrical in shape, preferably circular in cross-section, and preferably uniform in diameter. Positioned within a tube, or mandrel, such as the braided or woven horsehair tube, and preferably in contact therewith, is a similarly shaped wire helically or spirally wound to form a coil acting as a reinforcing member for said tube. Preferably, the respective ends of said hollow open mesh material tube are turned inwardly over the end portions of said reinforcing member thereby preventing any loose ends of the woven or braided mesh horsehair tube from protruding beyond its ends and thereby enabling easy handling in winding the hair therearound.

An object of my invention is to provide a frame-and-tube hair curler wherein said tube is maintained in position with respect to said frame without any substantial lateral displacement of said tube between the respective longitudinally extending frame sides and without any substantial lateral displacement of the locking means with respect to said tube.

Another object of my invention is to provide a frame-and-relatively thin walled tube hair curler wherein said tube is maintained in position with respect to said frame without any substantial lateral displacement of said tube between the respective longitudinally extending frame sides and without any substantial lateral displacement of the locking means with respect to said tube.

Other objects and features of my invention will be readily apparent from the following detailed description which is not limiting but only illustrative of the preferred embodiments of my invention.

FIGURE 1 is an exploded view in perspective of one embodiment of my hair curler.

FIGURE 2 is a longitudinal cross-sectional view of my hair curler of FIGURE 1 in closed position.

FIGURE 3 is an enlarged longitudinal cross-sectional view of a portion of still another embodiment of my hair curler.

FIGURE 4 is an enlarged longitudinal cross-sectional view of a portion of still another embodiment of my hair curler.

FIGURE 5 is an exploded view in perspective of another embodiment of my hair curler.

FIGURE 6 is a longitudinal cross-sectional view of my hair curler of FIGURE 5 in closed position.

FIGURE 7 is an exploded view in perspective of another embodiment of my hair curler.

FIGURE 8 is a longitudinal cross-sectional view of my hair curler of FIGURE 7 in closed position.

FIGURE 9 is an exploded view in perspective of another embodiment of my hair curler.

FIGURE 10 is a longitudinal cross-sectional view of my hair curler of FIGURE 9 in closed position.

FIGURE 11 is an exploded view in perspective of still another embodiment of my hair curler.

FIGURE 12 is a longitudinal cross-sectional view of my hair curler of FIGURE 11 in closed position.

FIGURE 13 is a view in perspective of a tubular member of another embodiment of my hair curler.

FIGURE 14 is a view in perspective of a tubular member of still another embodiment of my hair curler.

FIGURE 15 is a view in perspective of a tubular member of an additional embodiment of my hair curler.

FIGURE 16 is a view in perspective of a tubular member of still another embodiment of my hair curler.

FIGURE 17 is a view in perspective of a tubular member of still another embodiment of my hair curler.

FIGURE 18 is a view in perspective of a tubular member of an additional embodiment of my hair curler.

FIGURE 19 is a view in perspective of a tubular member of an additional embodiment of my hair curler.

FIGURE 20 is a view in perspective of a tubular member of still another embodiment of my hair curler.

FIGURE 21 is a view in perspective of a tubular member of still another embodiment of my hair curler.

FIGURE 22 is a view in perspective of a tubular member of still another embodiment of my hair curler.

More specifically, the hair curler 2 of my invention includes substantially preferably cylindrically shaped hollow flexible open mesh material tube 4 preferably of natural horsehair or artificial horsehair preferably circular of uniform diameter throughout its length and flexible frame member 42.

Frame member 42 includes longitudinally extending preferably parallel sides 44 and 46 and transversely extending flexible members 48 and 50 connecting flexible sides 44 and 46, respectively. Flexible member 48 is preferably formed of portion 52, U-shaped portion 54 and portion 56. U-shaped portion 54 consists of spaced-apart longitudinally extending preferably parallel sides 58 and 60 connected by transversely extending side 62. Transversely extending side 62 constitutes one of the transverse ends of frame 42 and is smaller than the diameter of tube 4. Portion 52 connects the end of flexible side 44 with the end of side 58, and portion 56 connects the end of flexible side 46 with the end of side 60. Portions 52 and 56 are preferably coplanar and preferably parallel to transversely extending, or bottom, side 62. Transversely extending flexible member 50 is formed of portion 64, U-shaped portion 66 and portion 68. U-shaped portion 66 consists of spaced-apart longitudinally extending preferably parallel sides 70 and 72 connected by transversely extending side 74. Transversely extending side 74 constitutes the other of the transverse ends of frame 42 and is likewise smaller than the diameter of tube 4. Portion 64 connects the ends of flexible side 44 with the end of flexible side 70, and portion 68 connects the end of flexible side 46 with the end of side 72. Portions 64 and 68 are preferably coplanar and preferably parallel to transversely extending side 74 and likewise preferably parallel to portions 52 and 56 of flexible member 48. As is clearly shown in the appended drawings, each of flexible sides 44 and 46 of frame 42 is substantially perpendicular to portion 52, portion 56 and transversely extending side 62 of flexible member 48 and also to portion 64, portion 68 and transversely extending side 74 of flexible member 50. Also, as is clearly shown in the appended drawings, end 62 of frame 42 is substantially parallel to the opposite end 74 of frame 42. In addition, as clearly shown in the appended drawings, U-shaped portions 54 and 66 are substantially centrally positioned in the transversely extending flexible members 48 and 50, and transverse ends 62 and 74 are substantially oppositely positioned with respect to each other.

Positioned within hollow tubular member 4, and preferably in contact therewith, as clearly shown in the appended drawings, is helically or spirally wound wire body 6 thereby to form a coil. Coil 6 has the shape similar to that of tube 4 and likewise is cylindrical and circular of uniform diameter throughout and is a reinforcing member for tube 4. Ends 8 and 10 of tube 4 are turned in over respective ends 12 and 14 of coil 6 to form inwardly turned portions 16, 16.

Integral with side 62 of U-shaped portion 54 is inwardly extending substantially flat conically shaped flexible tongue 80.

Positioned within tube 4 for substantially its length are spaced-apart rod members 18 and 20 which are, in turn, likewise respectively spaced from the inner surface of tube 4 and reinforcing coil 6, which is preferably in contact with tube 4. Each of said rod members 18 and 20 terminates at one end at, and is preferably integral with,

plate-like member 22, as clearly shown in FIGURES 1 and 2. Member 22 includes substantially flat portion 24 and offset portions 26 and 28 extending outwardly from the respective opposite ends 30 and 32 of portion 24. As is clearly shown in the appended drawings, each of ends 30 and 32 has a curvature complementary to the curvature of the inner surface of tube 4 and reinforcing coil 6 and is in substantial abutment therewith. Each of offset portions 26 and 28 overlaps and engages respective diametrically opposed portions of ends 34 and 36 of tube 4. Member 38 is preferably integral with flat portion 24, extends outwardly therefrom and is preferably centrally positioned with respect to tube 4, being preferably coaxially positioned with respect thereto. As is clearly shown in the appended drawings, member 38 has preferably a conically shaped recess 40 to receive tongue 80. However, member 38 may also have, in place of recess 40, a cylindrically shaped recess 82, as clearly shown in FIGURE 3. Also, member 38 may be positioned integral with offset portion 26 and flat portion 24, as clearly shown in FIGURE 4, and tongue 80 is integral with angularly disposed member 84 which is integral with transverse end 62. Each of rod members 18 and 20 terminates at its other end at, and is preferably integral with, plate-like member 86, as clearly shown in FIGURES 1 and 2. Preferably integral with said member 86 and extending outwardly of tube 4 is hinge means 88 for rotatably mounting frame 42 for rotation about tube 4. As is clearly shown in the appended drawings, hinge means 88 is pivotally mounted on transverse end 74. As is further clearly shown in the appended drawings, plate-like member 22, including flat portion 24 and offset portions 26 and 28, engages both tube 4, at its ends 34 and 36, and recessed member 38 thereby to prevent substantial lateral movement of member 38 with respect to tube 4 and to keep tube 4 in position with respect to frame 42, viz., to prevent any substantial displacement of tube 4 between the respective planes of longitudinally extending sides 44 and 46 of frame 42.

Referring to FIGURES 5 and 6 of the appended drawings, another embodiment of my hair curler is shown. Hair curler 90 includes tube 4, coil 6, and frame 42 of the embodiments of FIGURES 1 and 2, of FIGURE 3 and of FIGURE 4. Plate-like member 92 includes substantially flat portion 94, offset portions 96 and 98 and transverse clamp portions 1 and 3 depending from portions 96 and 98, respectively, at the respective ends 5 and 7 of offset portions 96 and 98. Each of the ends 9 and 11 of flat portion 24 has a curvature complementary to the curvature of the inner surface of tube 4 and reinforcing coil 6 and is in substantial abutment therewith. Each of offset portions 96 and 98 overlaps and engages respective diametrically opposed portions of ends 34 and 36 of tube 4. Clamp portions 1 and 3, as is clearly shown in FIGURES 5 and 6, snap-fit tightly and securely over ends 34 and 36, respectively, of tube 4. As in the embodiment of FIGURES 1 and 2, member 38 is preferably integral with flat portion 94 extending outwardly therefrom and is preferably centrally positioned with respect to tube 4, being preferably coaxially positioned with respect thereto. Likewise, member 38, in the embodiment of FIGURES 5 and 6, has preferably conically shaped recess 40 to receive tongue 80 and may have, in place of recess 40, cylindrically shaped recess 82 and may be positioned integral with offset portion 96 and flat portion 24, as in FIGURES 3 and 4, respectively. Likewise, in this embodiment of FIGURES 5 and 6, the structure of tongue 80 integral with angularly disposed member 84 which is integral with transverse end 62 of frame 42 is utilized. Plate-like member 194 includes clamp portions 13 and 15 depending therefrom and snap-fit tightly and securely over the ends 17 and 19 of tube 4. Hinge means 88 is integral with plate-like member 194 and extends outwardly of tube 4.

Referring to FIGURES 7 and 8 of the appended drawings, an additional embodiment of my hair curler is shown. Hair curler 21 includes tube 4, coil 6, frame 42, rod members 18 and 20, and plate-like member 36, as in the embodiment of FIGURES 1 and 2. Member 38 is positioned equidistantly from rod members 18 and 20 and is preferably integral with each of said members 18 and 20, as clearly shown in FIGURES 7 and 8. Snap-fitted into position between said rod members 18 and 20, in abutment with member 38, is plate-like member 23 having slots 25 and 27 for receiving said rod members 18 and 20, respectively. As is clearly shown in FIGURES 7 and 8, member 38 is preferably centrally positioned, being coaxially positioned with respect to tube 4. Plate-like member 23 overlaps and engages respective diametrically opposed portions of ends 34 and 36 of tube 4. Member 38 has preferably a conically shaped recess to receive tongue 80, but, as in the previously set forth embodiments, a cylindrically shaped recess can be utilized, as can the structure of FIGURE 4 wherein member 38 is positioned off-center with respect to tube 4. Preferably integral with member 86 and extending outwardly of tube 4 is hinge means 88 for rotatably mounting frame 42 for rotation about tube 4.

Referring to FIGURES 9 and 10 of the appended drawings, another embodiment of my hair curler is shown. Hair curler 29 includes tube 4, coil 6, and frame 42. Positioned within tube 4 for substantially its length is rod member 31, said member 31 being preferably coaxially positioned with respect to tube 4. Preferably integral with rod 31 at one of its ends and extending outwardly of tube 4 is hinge means 88 for rotatably mounting frame 42 for rotation about tube 4. Hinge means 88 is pivotally mounted on transverse end 74 of frame 42. Preferably integral with rod 31 at the other of its ends and extending outwardly of tube 4 is member 38. Member 38 has a preferably conically shaped recess 40 to receive tongue 80. In place of conically shaped recess 40, member 38 may have cylindrically shaped recess 82, as clearly shown in FIGURE 3. Snap-fitted into position about rod 31 and in abutment with member 38 is slotted plate-like member 33, the bottom portion of said slot 35 being circularly shaped and having a radius substantially equal to the radius of said rod 31 and the remainder of said slot 35 having a width slightly less than the diameter of rod 31. Member 33 consists of preferably circular portion 37 in substantial abutment with the inner surface of tube 4 and of portion 39 overlapping and engaging diametrically opposed portions of ends 34 and 36 of tube 4. Snap-fitted in position about rod 31 and in abutment with hinge means 88 is second member 33 having its circular portion 37 in substantial abutment with the inner surface of tube 4 and its portion 39 overlapping ends 17 and 19 of tube 4.

Referring to FIGURES 11 and 12, an additional embodiment of my hair curler is shown. Hair curler 41 includes tube 4, coil 6, and frame 42. Positioned within tube 4 for substantially its length is rod member 43 preferably coaxial with respect to tube 4. Preferably integral with rod 43, at one end thereof, is member 45, consisting of circular member 47, in substantial abutment with the inner surface of tube 4, and of plate member 49, preferably integral with member 47 and having outer horizontally planar curved end portions 51 and 53 overlapping and engaging respective diametrically opposed portions of ends 34 and 36 of tube 4. Preferably integral with plate member 49 and extending outwardly of tube 4 is preferably conically recessed member 38 preferably coaxially aligned with rod 43 and tube 4. At the other end of rod 43 and integral therewith is ball member 55 to be received in socket of member 57. Member 57 consists of circular member 59, which is in substantial abutment with the inner surface of tube 4, and of plate member 61 having horizontally planar curved ends 63

and 65 overlapping and engaging end portions 17 and 19 of tube 4. Integral with member 61 and extending outwardly of tube 4 is hinge means 88 pivotally mounted on transverse end 74.

Also within the scope of my invention is the use of an imperforate hollow relatively thin walled cylindrical tube 71, as shown in FIGURE 13, a hollow relatively thin walled cylindrical tube 73 having diamond shaped perforations 75, as shown in FIGURE 14, a similarly shaped tube 77 having rectangular perforations 79, as shown in FIGURE 15, a similarly shaped imperforate laminated tube 81, as shown in FIGURE 16, a similarly shaped laminated tube 83 having circular perforations 85, as shown in FIGURE 17, tube 71 having a plurality of upwardly projecting members 87, as shown in FIGURE 18, tube 73 having projecting members 87, as shown in FIGURE 19, tube 77 having projecting members 89, as shown in FIGURE 20, a similarly shaped tube 91 having circular perforations 93, as shown in FIGURE 21, and tube 91 having projecting members 95, as shown in FIGURE 22. Each of the foregoing tubular members is preferably of thermoplastic organic resinous material, such as polystyrene, polyethylene, polypropylene, nylon, or the like and is preferably flexible. Also, the imperforate tube 71, as shown in FIGURE 13, may be of a thermoplastic organic resinous material, such as cellulose acetate. Tube 81, as shown in FIGURE 16, consists of a liner 95 of any one of the foregoing resinous materials and a tubular layer 97 of a foam material such as polyurethane foam, thereover and in contact therewith. Likewise, tube 83, as shown in FIGURE 17, consists of a perforated liner 99 of any one of the foregoing resinous materials and a perforated layer 101 of a foam material such as polyurethane foam thereover and in contact therewith, the respective perforations in the liner and foam material coinciding to form circular perforations 85.

In each of the foregoing embodiments frame 42, tongue member 80, hinge means 88, recessed member 38, each and every rod member, each and every plate-like member, and all component elements as heretofore described, unless otherwise specifically stated, are flexible and are made of a light, flexible and durable thermoplastic organic resinous material, such as polyethylene, polypropylene, or the like.

Many alterations and changes may be made without departing from the spirit and scope of my invention which is set forth in the appended claims which are to be construed as broadly as possible in view of the prior art.

I claim:

1. A hair curler adapted to be positioned temporarily in the wearer's hair and to form a hair curl comprising, in combination, a cylindrical hollow tube, a flexible frame including spaced-apart longitudinally extending flexible sides and transversely extending flexible members connecting said sides, means on one end portion of said hair curlers for rotatably mounting said frame, an inwardly extending flexible tongue member integral with one of said transversely extending flexible members, a member positioned with respect to the opposite end portion of said tube and having recess means therein for receiving said tongue member, and means engaging both at least an outside portion of said tube and said positioned member for preventing substantial lateral movement of said positioned member with respect to said tube and for keeping said tube in position with respect to said frame member.

2. The hair curler of claim 1 wherein said frame, said means for rotatably mounting said frame, said tongue member, said positioned member, and said means for preventing substantial lateral movement of said positioned member and for keeping said tube in position are thermoplastic organic material.

3. The hair curler of claim 2 wherein said tube is of thermoplastic organic material.

4. The hair curler of claim 1 wherein said tongue member is substantially triangularly shaped.

5. The hair curler of claim 4 wherein said frame, said means for rotatably mounting said frame, said tongue member, said positioned member, and said means for preventing substantial lateral movement of said positioned member and for keeping said tube in position are thermoplastic organic material.

6. A hair curler adapted to be positioned temporarily in the wearer's hair and to form a hair curl comprising, in combination, a cylindrical hollow tube, a flexible frame including spaced-apart longitudinally extending flexible sides and transversely extending flexible members connecting said sides, an inwardly extending flexible tongue member integral with one of said transversely extending flexible members, a member positioned with respect to one end portion of said tube and having recess means therein for receiving said tongue member, means engaging both said tube and said positioned member for preventing substantial lateral movement of said positioned member with respect to said tube and for keeping said tube in position with respect to said frame member, at least one rod member positioned within said tube and operatively connected to said latter means, means on the opposite end portion of said hair curler for rotatably mounting said frame, said means for rotatably mounting said frame being operatively connected with said rod member.

7. The hair curler of claim 6 wherein said frame, said tongue member, said positioned member, said means for preventing substantial lateral movement of said positioned member and for keeping said tube in position, said rod member, and said means for rotatably mounting said frame are thermoplastic organic material.

8. The hair curler of claim 7 wherein said tube is of thermoplastic organic material.

9. The hair curler of claim 6 wherein said tongue member is substantially triangularly shaped.

10. The hair curler of claim 9 wherein said frame, said tongue member, said positioned member, said substantially triangularly shaped means for preventing substantial lateral movement of said positioned member and for keeping said tube in position, said rod member, and said means for rotatably mounting said frame are thermoplastic organic material.

11. A hair curler adapted to be positioned temporarily in the wearer's hair and to form a hair curl comprising, in combination, a cylindrical hollow tube, a frame including spaced-apart longitudinally extending sides and transversely extending members connecting said sides, means on one end portion of said hair curler for rotatably mounting said frame, an inwardly extending flexible tongue member integral with one of said transversely extending members, a member positioned with respect to the opposite end portion of said tube and having recess means therein for receiving said tongue member, and means engaging both at least an outside portion of said tube and said positioned member for preventing substantial lateral movement of said positioned member with respect to said tube and for keeping said tube member in position with respect to said frame member.

12. A hair curler adapted to be positioned temporarily in the wearer's hair and to form a hair curl comprising, in combination, a cylindrical hollow tube, a frame including spaced-apart longitudinally extending sides and transversely extending members connecting said sides, an inwardly extending flexible tongue member integral with one of said transversely extending members, a member positioned with respect to one end portion of said tube and having recess means therein for receiving said tongue member, means engaging both said tube and said positioned member for preventing substantial lateral movement of said positioned member with respect to said tube and for keeping said tube in position with respect to said frame member, at least one rod member positioned within said tube and operatively connected to said latter means,

means on the opposite end portion of said hair curler for rotatably mounting said frame, said means for rotatably mounting said frame being operatively connected with said rod member.

13. A hair curler adapted to be positioned temporarily in the wearer's hair and to form a hair curl comprising, in combination, a cylindrical hollow tube, a flexible frame including spaced-apart longitudinally extending flexible sides and transversely extending flexible members connecting said sides, means on one end portion of said hair curler for rotatably mounting said frame, an inwardly extending flexible tongue member integral with one of said transversely extending flexible members, a member centrally positioned with respect to the opposite end portion of said tube and having recess means therein for receiving said tongue member, and means engaging both at least an outside portion of said tube and said centrally positioned member for preventing substantial lateral movement of said centrally positioned member with respect to said tube and for keeping said tube in position with respect to said frame member.

14. The hair curler of claim 13 wherein said frame, said means for rotatably mounting said frame, said tongue member, said centrally positioned member, and said means for preventing substantial lateral movement of said centrally positioned member and for keeping said tube in position are thermoplastic organic material.

15. The hair curler of claim 14 wherein said tube is of thermoplastic organic material.

16. The hair curler of claim 13 wherein said tongue member is substantially triangularly shaped.

17. The hair curler of claim 16 wherein said frame, said means for rotatably mounting said frame, said tongue member, said centrally positioned member, and said means for preventing substantial lateral movement of said centrally positioned member and for keeping said tube in position are thermoplastic organic material.

18. A hair curler adapted to be positioned temporarily in the wearer's hair and to form a hair curl comprising, in combination, a cylindrical hollow tube, a flexible frame including spaced-apart longitudinally extending flexible sides and transversely extending flexible members connecting said sides, an inwardly extending flexible tongue member integral with one of said transversely extending flexible members, a member centrally positioned with respect to one end portion of said tube and having recess means therein for receiving said tongue member, means engaging both said tube and said centrally positioned member for preventing substantial lateral movement of said centrally positioned member with respect to said tube and for keeping said tube in position with respect to said frame member, at least one rod member positioned within said tube and operatively connected to said latter means, means on the opposite end portion of said hair curler for rotatably mounting said frame, said means for rotatably mounting said frame being operatively connected with said rod member.

19. The hair curler of claim 18 wherein said frame, said tongue member, said centrally positioned member, said means for preventing substantial lateral movement of said centrally positioned member and for keeping said tube in position, said rod member and said means for rotatably mounting said frame are thermoplastic organic material.

20. The hair curler of claim 19 wherein said tube is of thermoplastic organic material.

21. The hair curler of claim 18 wherein said tongue member is substantially triangularly shaped.

22. The hair curler of claim 21 wherein said frame, said tongue member, said centrally positioned member, said means for preventing substantially lateral movement of said centrally positioned member and for keeping said tube in position, said rod member, and said means for rotatably mounting said frame are thermoplastic organic material.

23. A hair curler adapted to be positioned temporarily in the wearer's hair to form a hair curl comprising, in combination, a cylindrical hollow tube, a frame including spaced-apart longitudinally extending sides and transversely extending members connecting said sides, means on one end portion of said hair curler for rotatably mounting said frame, an inwardly extending flexible tongue member integral with one of said transversely extending members, a member centrally positioned with respect to the opposite end portion of said tube and having recess means therein for receiving said tongue member, and means engaging both at least an outside portion of said tube and said centrally positioned member for preventing substantial lateral movement of said centrally positioned member with respect to said tube and for keeping said tube member in position with respect to said frame member.

24. A hair curler adapted to be positioned temporarily in the wearer's hair and to form a hair curl comprising, in combination, a cylindrical hollow tube, a frame including spaced-apart longitudinally extending sides and transversely extending members connecting said sides, an inwardly extending flexible tongue member integral with one of said transversely extending members, a member centrally positioned with respect to one end portion of said tube and having recess means therein for receiving said tongue member, means engaging both said tube and said centrally positioned member for preventing substantial lateral movement of said centrally positioned member with respect to said tube and for keeping said tube in position with respect to said frame member, at least one rod member positioned within said tube and operatively connected to said latter means, and means on the opposite end portion of said hair curler for rotatably mounting said frame, said means for rotatably mounting said frame being operatively connected with said rod member.

25. A hair curler adapted to be positioned temporarily in the wearer's hair and to form a hair curl comprising, in combination, a cylindrical hollow tube, a flexible frame including spaced-apart longitudinally extending flexible sides and transversely extending flexible members connecting said sides, said frame being rotatably mounted on one end portion of said tube, an inwardly extending flexible tongue member integral with one of said transversely extending flexible members, a member positioned with respect to the opposite end portion of said tube and having recess means therein for receiving said tongue

member, and means engaging both at least an outside portion of said tube and said positioned member for preventing substantial lateral movement of said positioned member with respect to said tube and for keeping said tube in position with respect to said frame member.

26. A hair curler adapted to be positioned temporarily in the wearer's hair and to form a hair curl comprising, in combination, a cylindrical hollow tube, a frame including spaced-apart longitudinally extending sides and transversely extending members connecting said sides, said frame being rotatably mounted on one end portion of said tube, an inwardly extending flexible tongue member integral with one of said transversely extending members, a member positioned with respect to the opposite end portion of said tube and having recess means therein for receiving said tongue member, and means engaging both at least an outside portion of said tube and said positioned member for preventing substantial lateral movement of said positioned member with respect to said tube and for keeping said tube member in position with respect to said frame member.

27. A hair curler adapted to be positioned temporarily in the wearer's hair and to form a hair curl comprising, in combination, a cylindrical hollow tube, a flexible frame including spaced-apart longitudinally extending flexible sides and transversely extending members connecting said sides, said frame being rotatably mounted on one end portion of said tube, an inwardly extending flexible tongue member integral with one of said transversely extending flexible members, a member centrally positioned with respect to the opposite end portion of said tube and having recess means therein for receiving said tongue member, and means engaging both at least an outside portion of said tube and said centrally positioned member for preventing substantial lateral movement of said centrally positioned member with respect to said tube and for keeping said tube in position with respect to said frame member.

References Cited in the file of this patent

UNITED STATES PATENTS

2,473,115	6/49	Vaughn	-----	132—41
2,937,649	5/60	Gresham	-----	132—41

RICHARD A. GAUDET, *Primary Examiner.*

JORDAN FRANKLIN, *Examiner.*