



US 20040154356A1

(19) **United States**

(12) **Patent Application Publication** (10) **Pub. No.: US 2004/0154356 A1**

Kim et al.

(43) **Pub. Date: Aug. 12, 2004**

(54) **DRUM TYPE WASHING MACHINE**

(30) **Foreign Application Priority Data**

Nov. 29, 2002 (KR)..... P2002-0075359

(76) Inventors: **Jong Seok Kim**, Changwon-si (KR);
Yang Hwan No, Changwon-si (KR);
Han Ki Cho, Changwon-si (KR); **Yeon Su Jung**, Changwon-si (KR); **Jung Hoon Kang**, Changwong-si (KR);
Myung Sik Park, Changwong-si (KR);
Young Hoon Ha, Mason-si (KR)

Publication Classification

(51) **Int. Cl.⁷** **D06F 39/12**
(52) **U.S. Cl.** **68/208; 68/23 R**

(57) **ABSTRACT**

Disclosed is a drum type washing machine, and more particularly, a tub of a drum type washing machine enabling to effectively drain water and foam in the tub. The present invention includes a tub body having a drum installed rotatably inside, a sump at a bottom of the tub body to store water or foam, a drain outlet at a bottom of the sump wherein the water or foam is discharged via the drain outlet, and a rib at one side of the sump to prevent the water or foam from deviating from the sump.

Correspondence Address:
BIRCH STEWART KOLASCH & BIRCH
PO BOX 747
FALLS CHURCH, VA 22040-0747 (US)

(21) Appl. No.: **10/721,339**

(22) Filed: **Nov. 26, 2003**

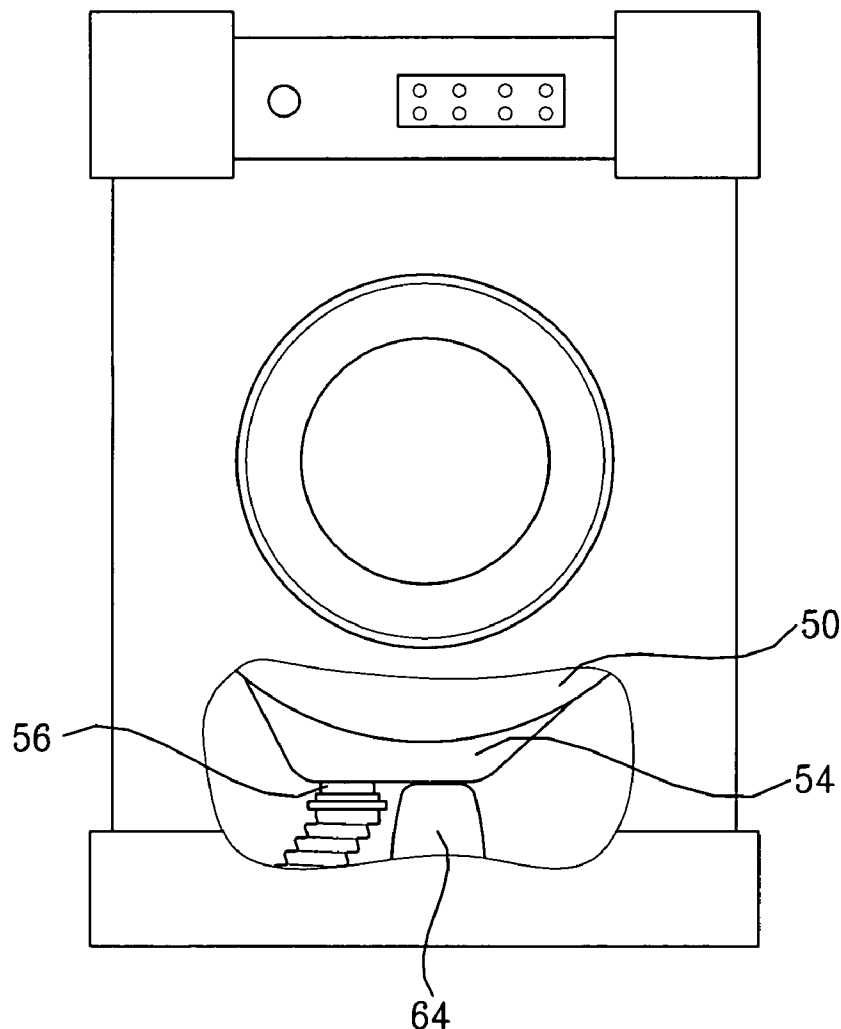

FIG. 1

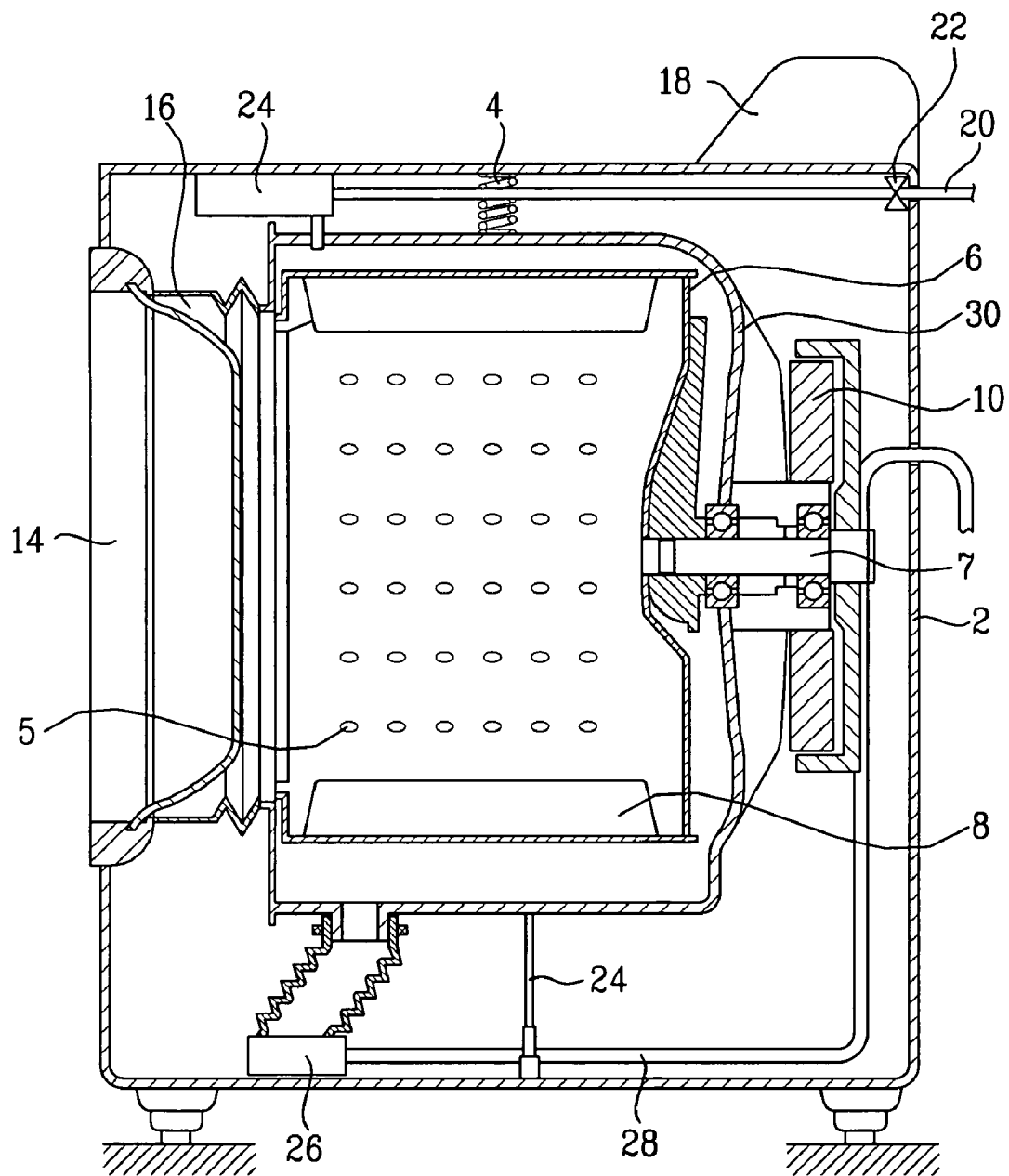

FIG. 2

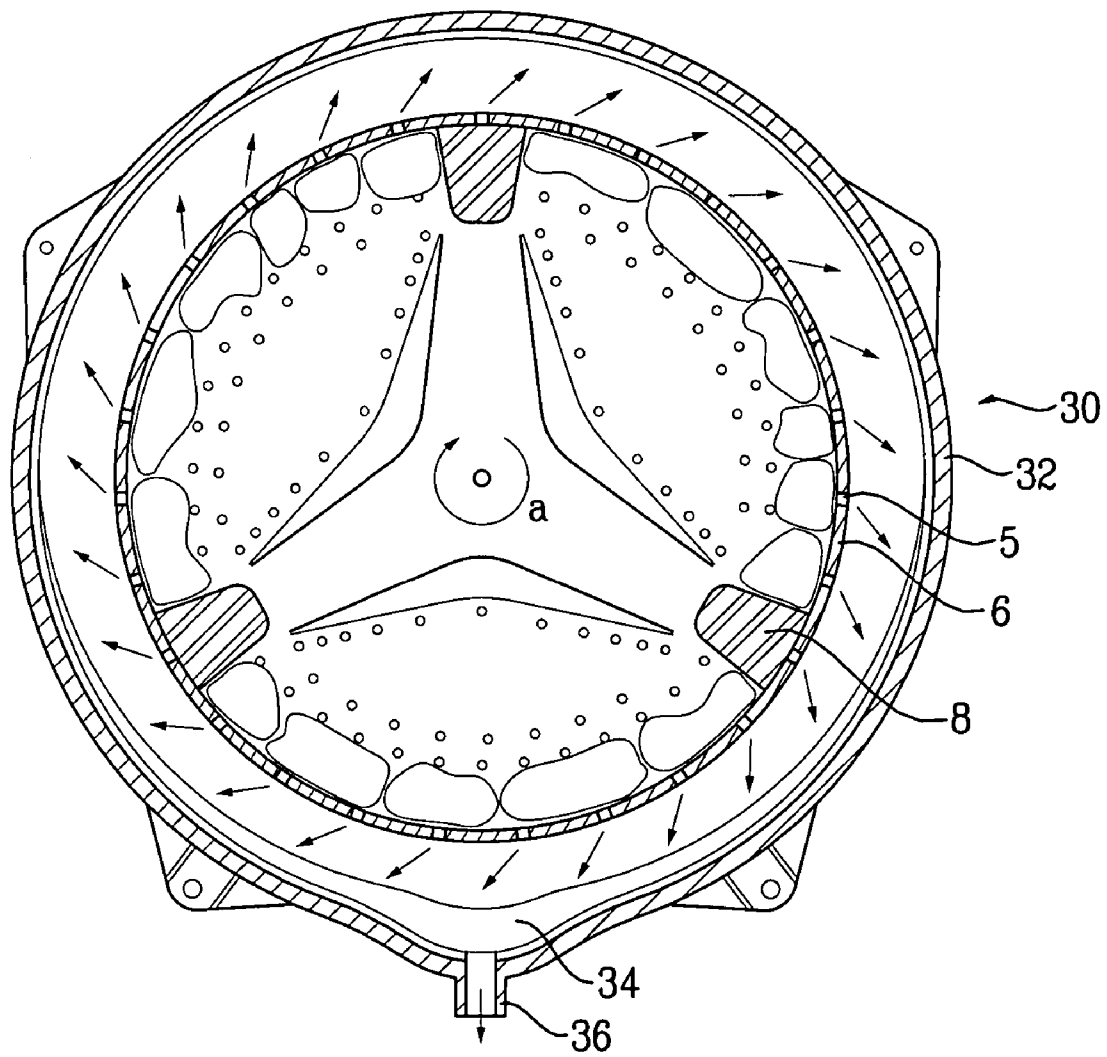

FIG. 3

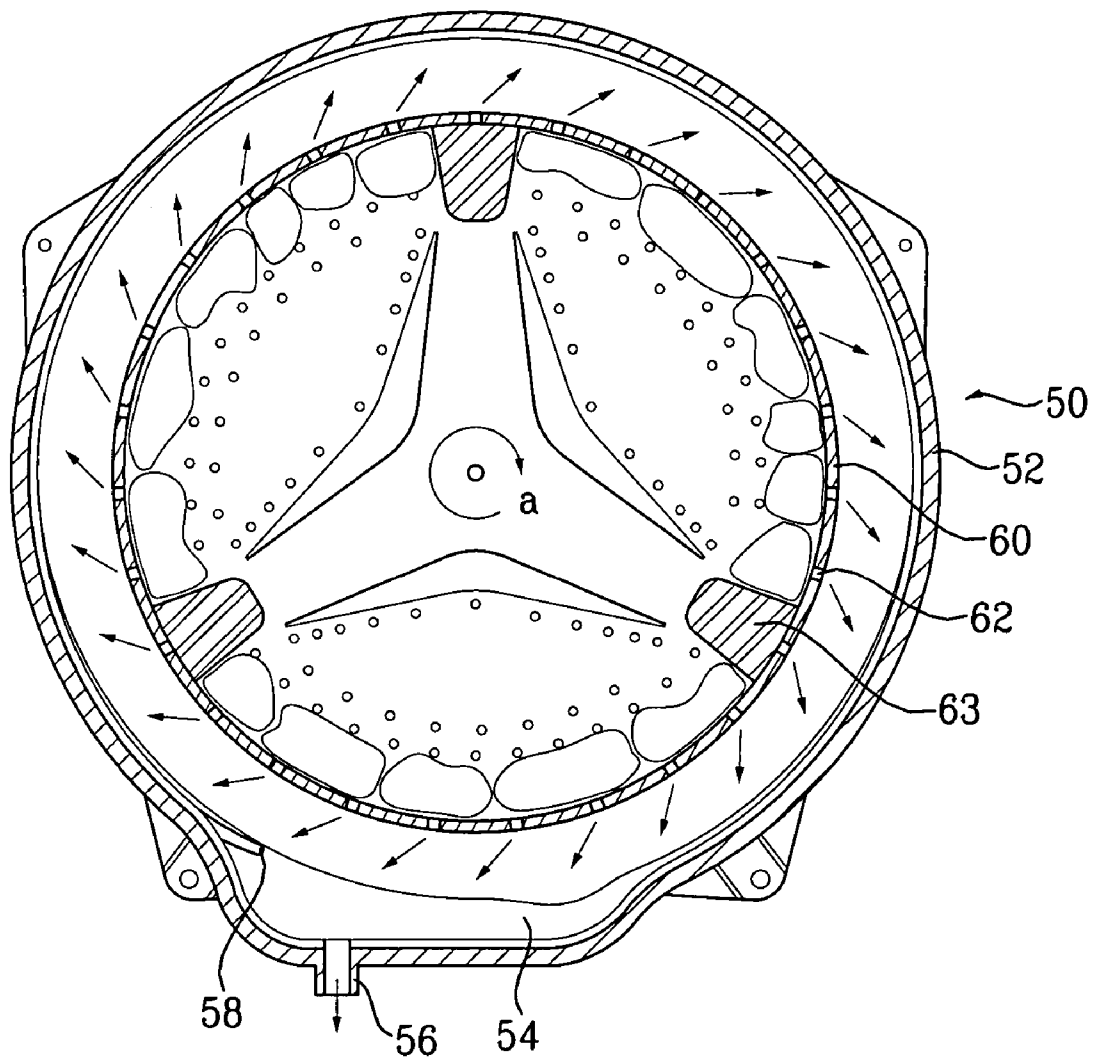
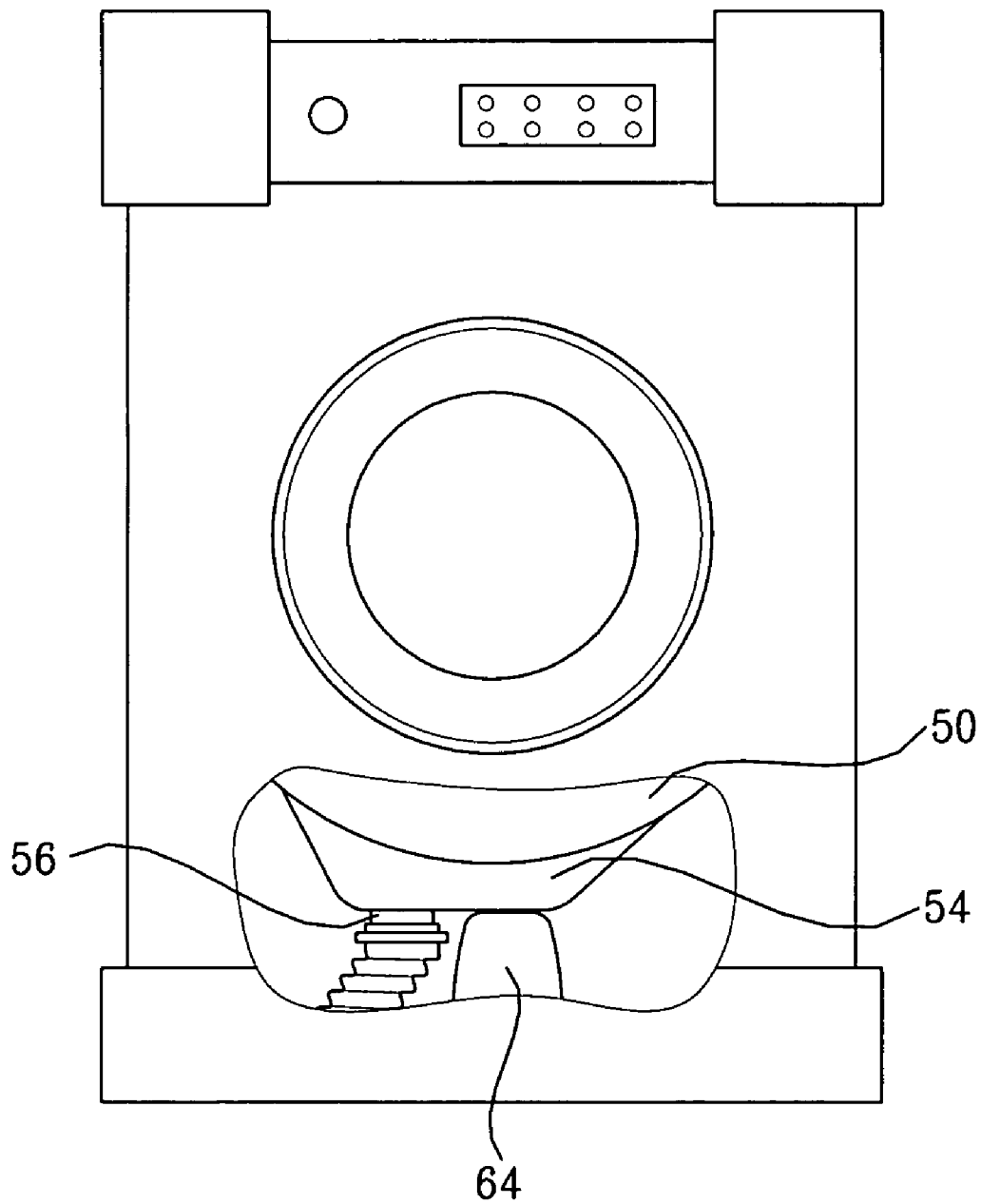

FIG. 4



DRUM TYPE WASHING MACHINE

[0001] This application claims the benefit of Korean Application(s) No. 10-2002-0075359 filed on Nov. 29, 2002, which is/are hereby incorporated by reference.

BACKGROUND OF THE INVENTION

[0002] 1. Field of the Invention

[0003] The present invention relates to a drum type washing machine, and more particularly, to a tub of a drum type washing machine enabling to effectively drain water and foam in the tub.

[0004] 2. Discussion of the Related Art

[0005] Generally, in a drum type washing machine, a drum holding the laundry, water, and detergent inside is rotated to lift the laundry up by protrusions to perform washing using the shock energy of the laundry falling down and a frictional force thereof.

[0006] Such a drum type washing machine avoids causing damage to the laundry and prevents the laundry from being entangled, thereby prevailing in use gradually.

[0007] FIG. 1 is a schematic cross-sectional view of a drum type washing machine according to a related art.

[0008] Referring to FIG. 1, in a drum type washing machine according to a related art, a cabinet 2 forms an exterior. An entrance is formed at a front side of the cabinet 2, and a door 14 is installed at the entrance to prevent a laundry from popping out. And, a tub 30 supported by a spring 4 is installed in the cabinet 2 to hold water.

[0009] A drum 6 in which the laundry and detergent are put is rotatably installed in the tub 30. A rotational shaft 7 coupled with a motor 10 is installed in rear of the drum 6 to transfer a driving force to the drum 6. And, a plurality of lifts 8 are installed on an inside of the drum 6 to pull up the laundry to fall. Moreover, a multitude of perforated holes 5 through which the water and foam communicate are formed at the drum 6.

[0010] Meanwhile, a gasket 16 formed of such an elastic material as rubber is installed between the door 14 and the tub 30. The gasket 16 alleviates a shock generated from a rotation of the drum 6 as well as makes the door 14 airtight to prevent the water from leaking.

[0011] A damper 24 is installed at one side under the tub 30. The damper 24 attenuates the vibration transferred to the tub 30 through the rotational shaft 7 while the washing machine operates.

[0012] Moreover, a control panel 18 for controlling an operation of the drum type washing machine is installed on a top of the cabinet 2. A water supply hose 20, a water supply valve 22, and a detergent box 24 are installed in an upper part of the cabinet 2 to supply the water and detergent to the tub 30. And, a drain pump 26 and a drain hose 28 are installed at one side under the tub 30 to circulate or discharge the water.

[0013] FIG. 2 is a cross-sectional view of a tub and a drum of a drum type washing machine according to a related art for showing an operation on dewatering.

[0014] Referring to FIG. 2, a tub 30 according to a related art consists of a tub body 32 having a drum 6 installed rotatably inside to hold a laundry and a sump 34 at a lower part of the tub body 32 to store water or foam therein. And, a drain outlet 36 for discharging the water or foam in the sump 34 is formed at a bottom center of the sump 34.

[0015] In this case, a central portion of a bottom of the tub body 32 is recessed downward to construct the sump 34 for storing the water and foam.

[0016] In the above-constructed drum type washing machine according to the related art, as the drum 6 rotates at high speed clockwise 'a' on dewatering, the water and foam is discharged between the drum 6 and the tub 30 via the perforated holes 5 at the drum 6. The discharged water and foam gathers in the sump 34 along an inner circumference of the tub body 32.

[0017] However, the related art drum type washing machine has the following problems or disadvantages.

[0018] First of all, a volume of the sump is so small that the water and foam on dewatering fail to be stored in the sump. Instead, the water and foam deviates from the sump by the rotational force of the drum to move along the inner circumference of the tub body, whereby the water and foam fail to be smoothly drained through the drain outlet.

[0019] Moreover, as a drum type washing machine increases in size lately, so a laundry amount increases. Hence, the amount of the water and foam increases as well as a centrifugal force of the drum, whereby the related art sump is inappropriate for such a washing machine of large-capacity.

SUMMARY OF THE INVENTION

[0020] Accordingly, the present invention is directed to a drum type washing machine that substantially obviates one or more of the problems due to limitations and disadvantages of the related art.

[0021] An object of the present invention, which has been devised to solve the foregoing problem, lies in providing a tub of a drum type washing machine, by which water and foam in the tub are effectively drained.

[0022] Additional features and advantages of the invention will be set forth in the description which follows, and in part will be apparent to those having ordinary skill in the art upon examination of the following or may be learned from a practice of the invention. The objectives and other advantages of the invention will be realized and attained by the subject matter particularly pointed out in the specification and claims hereof as well as in the appended drawings.

[0023] To achieve these objects and other advantages in accordance with the present invention, as embodied and broadly described herein, there is provided a tub of a drum type washing machine including a tub body having a drum installed rotatably inside, a sump at a bottom of the tub body to store water or foam, a drain outlet at a bottom of the sump wherein the water or foam is discharged via the drain outlet, and a rib at one side of the sump to prevent the water or foam from deviating from the sump.

[0024] In this case, the sump is expanded to increase a capacity of storing the water and foam therein, and the drain outlet is formed at an expanded portion of the sump.

[0025] And, the rib is formed at an edge top of the expanded sump to prevent the water or foam from deviating from the sump by a rotation of the drum.

[0026] Moreover, the sump is preferably expanded in a rotational direction of the drum on dewatering to increase a capacity of storing the water and foam therein.

[0027] In this case, the drain outlet is formed at an expanded portion of the sump and the rib is formed at an edge top of the expanded sump to prevent the water or foam from deviating from the sump by a rotation of the drum.

[0028] In another aspect of the present invention, there is provided a drum type washing machine including a cabinet forming an exterior, a drum in the cabinet to hold a laundry and a detergent therein, a tub body having the drum installed rotatably inside, a sump at a bottom of the tub body to store water or foam, a drain outlet at a bottom of the sump wherein the water or foam is discharged via the drain outlet, and a rib at one side of the sump to prevent the water or foam from deviating from the sump.

[0029] It is to be understood that both the foregoing explanation and the following detailed description of the present invention are exemplary and illustrative and are intended to provide further explanation of the invention as claimed.

BRIEF DESCRIPTION OF THE DRAWINGS

[0030] The accompanying drawings, which are included to provide a further understanding of the invention and are incorporated in and constitute a part of this application, illustrate embodiment(s) of the invention and together with the description serve to explain the principle of the invention. In the drawings:

[0031] FIG. 1 is a schematic cross-sectional view of a drum type washing machine according to a related art;

[0032] FIG. 2 is a cross-sectional view of a tub and a drum of a drum type washing machine according to a related art for showing an operation on dewatering;

[0033] FIG. 3 is a cross-sectional view of a tub and a drum of a drum type washing machine according to the present invention for showing an operation on dewatering; and

[0034] FIG. 4 is a perspective view of a drum type washing machine according to the present invention, in which an interior is partially shown.

DETAILED DESCRIPTION OF THE PREFERRED EMBODIMENT(S)

[0035] Reference will now be made in detail to the preferred embodiment(s) of the present invention, examples of which are illustrated in the accompanying drawings. Throughout the drawings, like elements are indicated using the same or similar reference designations where possible.

[0036] FIG. 3 is a cross-sectional view of a tub and a drum of a drum type washing machine according to the present invention for showing an operation on dewatering and FIG. 4 is a perspective view of a drum type washing machine according to the present invention, in which an interior is partially shown.

[0037] In a drum type washing machine according to the present invention, like elements, except a tub 50 holding water and a drum 60 rotatably provided in the tub 50, are indicated using the same or similar reference designations of the related art where possible.

[0038] Referring to FIG. 3, a tub 50 according to the present invention includes a tub body 52. And, a drum 60 is rotatably installed in the tub body 52 to hold a laundry. A multitude of perforated holes 62 through which the water and foam communicate are formed at the drum 60, and a plurality of lifts 63 are formed inside to pull the laundry to fall.

[0039] A sump 54 is formed at a lower part of the tub body 52 to store the water or foam therein. And, a drain outlet 56 for discharging the water or foam in the sump 54 is formed at a bottom center of the sump 54.

[0040] Moreover, a rib 58 is formed at one side of the sump 54 to prevent the water or foam from deviating from the sump 54.

[0041] In this case, the sump 54 expands to increase a capacity of storing the water and foam. The sump 54 preferably extends in the same direction of the rotational direction 'a' of the drum 60 on dewatering.

[0042] Of course, the sump 54 can extend to both sides to increase the capacity of storing the water and foam more.

[0043] Besides, the drain outlet 56 is formed at the expanding portion of the sump 54 and the rib 58 protrudes from an edge top of the expanding portion of the sump 54 to leave a predetermined distance from the drain outlet 56 in a rotational direction of the drum 60.

[0044] The rib 58 prevents the water and foam from deviating from the sump 54 to move along the tub body 52 in the same direction of the drum 60 by the rotational force of the drum 60, thereby collecting the water and foam in the sump 54.

[0045] Of course, in case that the sump 54 extends to both sides, the drain outlet 56 can be formed at each side of the expanding sump 54 as well as the rib 58 can be formed at each edge top of the expanding sump 54.

[0046] Meanwhile, the drain outlet 56, as shown in FIG. 4, is provided to incline to one side from a bottom center of the sump 54 as the sump 54 expands. Hence, a tub fixing packing 64 may be installed at the bottom center of the sump 54. The tub fixing packing 64 is installed at the bottom of the sump 64 to securely fix the tub 50 thereto on packaging the drum type washing machine.

[0047] An operation of the above-constructed drum type washing machine according to the present invention is explained as follows.

[0048] First of all, once a power is applied to the drum type washing machine, water and detergent are supplied to the tub 50 according to an amount of the laundry put in the drum 60.

[0049] After the tub 50 is sufficiently filled with the supplied water, a washing step is executed so that the drum 60 is rotated by the motor 10. In this case, the laundry in the drum 60 is lifted up to fall down for washing.

[0050] After completion of the washing step, a draining step is initiated to discharge the water and foam in the tub 50. In this case, the drain pump 26 pumps the water and foam to drain via the drain outlet 56 and the drain hose 28 outside the drum type washing machine.

[0051] After completion of the draining step, new water is supplied to the tub 50 and the drum 60 is then rotated to perform a rinsing step for rinsing the laundry. After completion of the rinsing step, the draining step is repeated.

[0052] Meanwhile, the drain step includes a dewatering step to effectively remove the water and foam involved in the laundry. Moreover, in case of completing all washing steps, the dewatering step is performed to finally eliminate the water involved in the laundry.

[0053] In the dewatering step, the drum 60 is rotated in one direction 'a' at high speed by the motor 10, and the laundry is pushed toward the inner circumference of the drum 60 by the corresponding centrifugal force.

[0054] Moreover, the water and foam involved in the laundry are discharged between the drum 60 and the tub body 52 via the perforated holes of the drum 60 by the centrifugal force, and the discharged water and foam gather in the sump 54 along the inner circumference of the tub body 52.

[0055] Yet, a considerable amount of the water and foam intends to deviate from the sump 54 to move in a rotational direction of the drum 60 along the inner circumference of the tub body 52 by the rotational force of the drum 60.

[0056] In this case, the water and foam are blocked by the rib 58 so as not to move further but are retrieved to the sump 54 to be discharged via the drain outlet 56.

[0057] Accordingly, the drum type washing machine according to the present invention has the following effects or advantages.

[0058] First of all, the rib protruding from the expanding edge top of the sump prevents the water and foam from moving along the tub body by the rotational force of the drum. Therefore, the water and foam are retrieved to the sump to be effectively discharged.

[0059] Secondly, the expanding sump enables to store a massive amount of water and foam therein, thereby being applicable to handling a considerably large amount of water and foam in a big-capacity drum type washing machine and the like.

[0060] Thirdly, the drain outlet is formed to incline to one side from the bottom center of the sump, whereby the tub fixing packing is installed at the bottom of the sump to securely fix the tub thereto on packaging the drum type washing machine. Therefore, the drum type washing machine is prevented from being broken as the tub rocks on transportation.

[0061] It will be apparent to those skilled in the art that various modifications and variations can be made in the present invention without departing from the spirit or scope of the invention. Thus, it is intended that the present invention cover such modifications and variations, provided they come within the scope of the appended claims and their equivalents.

What is claimed is:

- 1. A tub of a drum type washing machine, comprising:
 - a tub body having a drum installed rotatably inside;
 - a sump at a bottom of the tub body to store water or foam;
 - a drain outlet at a bottom of the sump wherein the water or foam is discharged via the drain outlet; and
 - a rib at one side of the sump to prevent the water or foam from deviating from the sump.
- 2. The tub as claimed in claim 1, wherein the sump is expanded to increase a capacity of storing the water and foam therein.
- 3. The tub as claimed in claim 2, wherein the drain outlet is formed at an expanded portion of the sump.
- 4. The tub as claimed in claim 2, wherein the rib is formed at an edge top of the expanded sump to prevent the water or foam from deviating from the sump by a rotation of the drum.
- 5. The tub as claimed in claim 1, wherein the sump is expanded in a rotational direction of the drum on dewatering to increase a capacity of storing the water and foam therein.
- 6. The tub as claimed in claim 5, wherein the drain outlet is formed at an expanded portion of the sump.
- 7. The tub as claimed in claim 5, wherein the rib is formed at an edge top of the expanded sump to prevent the water or foam from deviating from the sump by a rotation of the drum.
- 8. A drum type washing machine, comprising:
 - a cabinet forming an exterior;
 - a drum in the cabinet to hold a laundry and a detergent therein;
 - a tub body having the drum installed rotatably inside;
 - a sump at a bottom of the tub body to store water or foam;
 - a drain outlet at a bottom of the sump wherein the water or foam is discharged via the drain outlet; and
 - a rib at one side of the sump to prevent the water or foam from deviating from the sump.
- 9. The drum type washing machine as claimed in claim 8, wherein the sump is expanded to increase a capacity of storing the water and foam therein.
- 10. The drum type washing machine as claimed in claim 9, wherein the drain outlet is formed at an expanded portion of the sump.
- 11. The drum type washing machine as claimed in claim 9, wherein the rib is formed at an edge top of the expanded sump to prevent the water or foam from deviating from the sump by a rotation of the drum.
- 12. The drum type washing machine as claimed in claim 8, wherein the sump is expanded in a rotational direction of the drum on dewatering to increase a capacity of storing the water and foam therein.
- 13. The drum type washing machine as claimed in claim 12, wherein the drain outlet is formed at an expanded portion of the sump.
- 14. The drum type washing machine as claimed in claim 12, wherein the rib is formed at an edge top of the expanded sump to prevent the water or foam from deviating from the sump by a rotation of the drum.