



US 20050176365A1

(19) **United States**

(12) **Patent Application Publication**
Green, SR. et al.

(10) **Pub. No.: US 2005/0176365 A1**

(43) **Pub. Date: Aug. 11, 2005**

(54) **SATELLITE BROADCAST RECEIVING AND DISTRIBUTION SYSTEM**

(75) Inventors: **James A. Green SR.**, Tallahassee, FL (US); **Austin S. Coker JR.**, Tallahassee, FL (US)

No. 08/838,677, filed on Apr. 9, 1997, now Pat. No. 5,805,975, and which is a continuation of application No. 08/394,234, filed on Feb. 22, 1995, now abandoned.

Publication Classification

(51) **Int. Cl.⁷ H04H 1/00**

(52) **U.S. Cl. 455/3.02**

Correspondence Address:
NIXON & VANDERHYE, PC
901 NORTH GLEBE ROAD, 11TH FLOOR
ARLINGTON, VA 22203 (US)

(57) **ABSTRACT**

(73) Assignee: **Global Communications, Inc.**, Tallahassee, FL

(21) Appl. No.: **11/086,581**

(22) Filed: **Mar. 23, 2005**

The present invention provides a satellite broadcast receiving and distribution system that will permit for the transmission of vertical and horizontal or left-hand circular and right-hand circular polarization signals simultaneously via a single coaxial cable. The system of the present invention will accommodate two different polarity commands from two or more different sources at the same time. This satellite broadcast receiving and distribution system of the present invention will provide for the signals received from the satellite to be converted to standard frequencies so as to permit for signals to travel via existing wiring which the present day amplifiers can transport in buildings, high-rises, hospitals, and the like so that satellite broadcasting can be viewed by numerous individuals by way of a single satellite antenna.

Related U.S. Application Data

(63) Continuation of application No. 10/052,344, filed on Jan. 23, 2002, which is a continuation of application No. 09/664,443, filed on Sep. 18, 2000, now Pat. No. 6,397,038, and which is a continuation of application No. 09/001,484, filed on Dec. 31, 1997, now Pat. No. 6,122,482, and which is a continuation of application

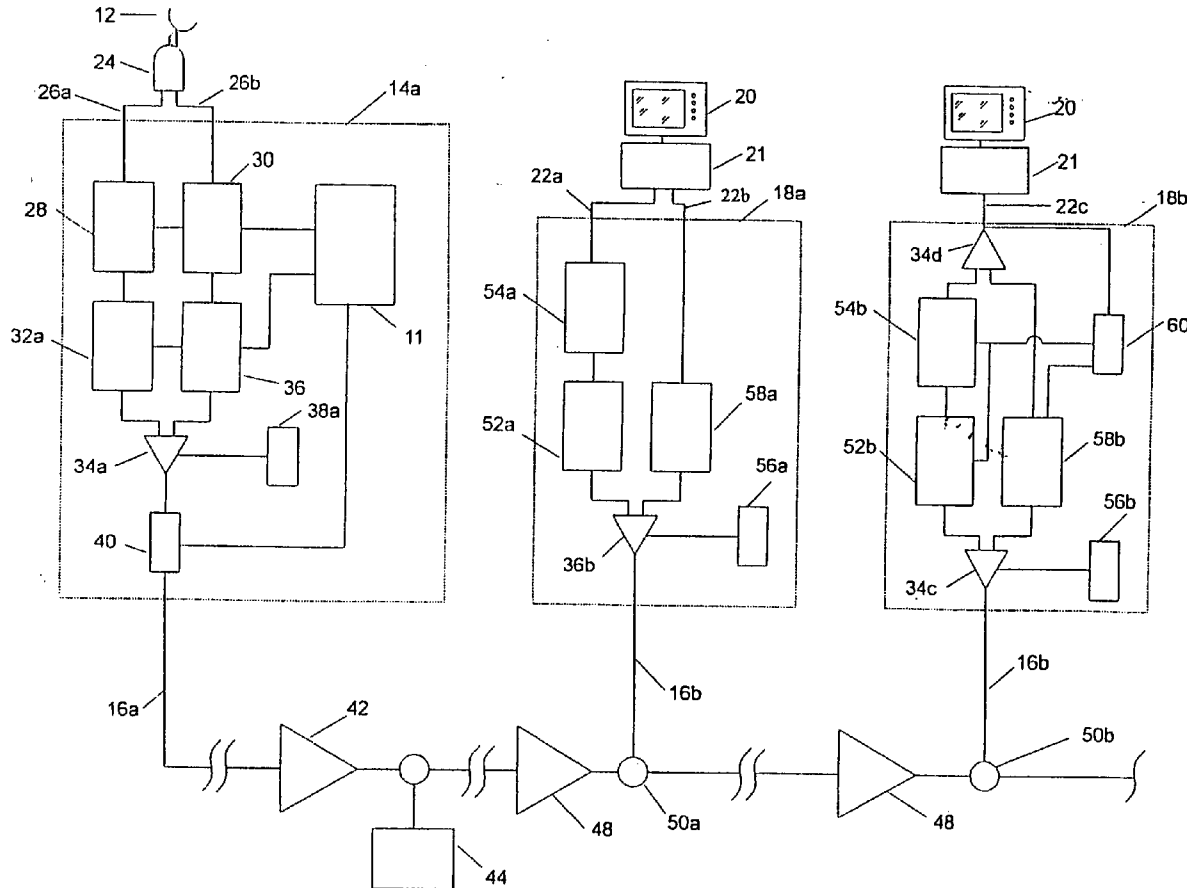

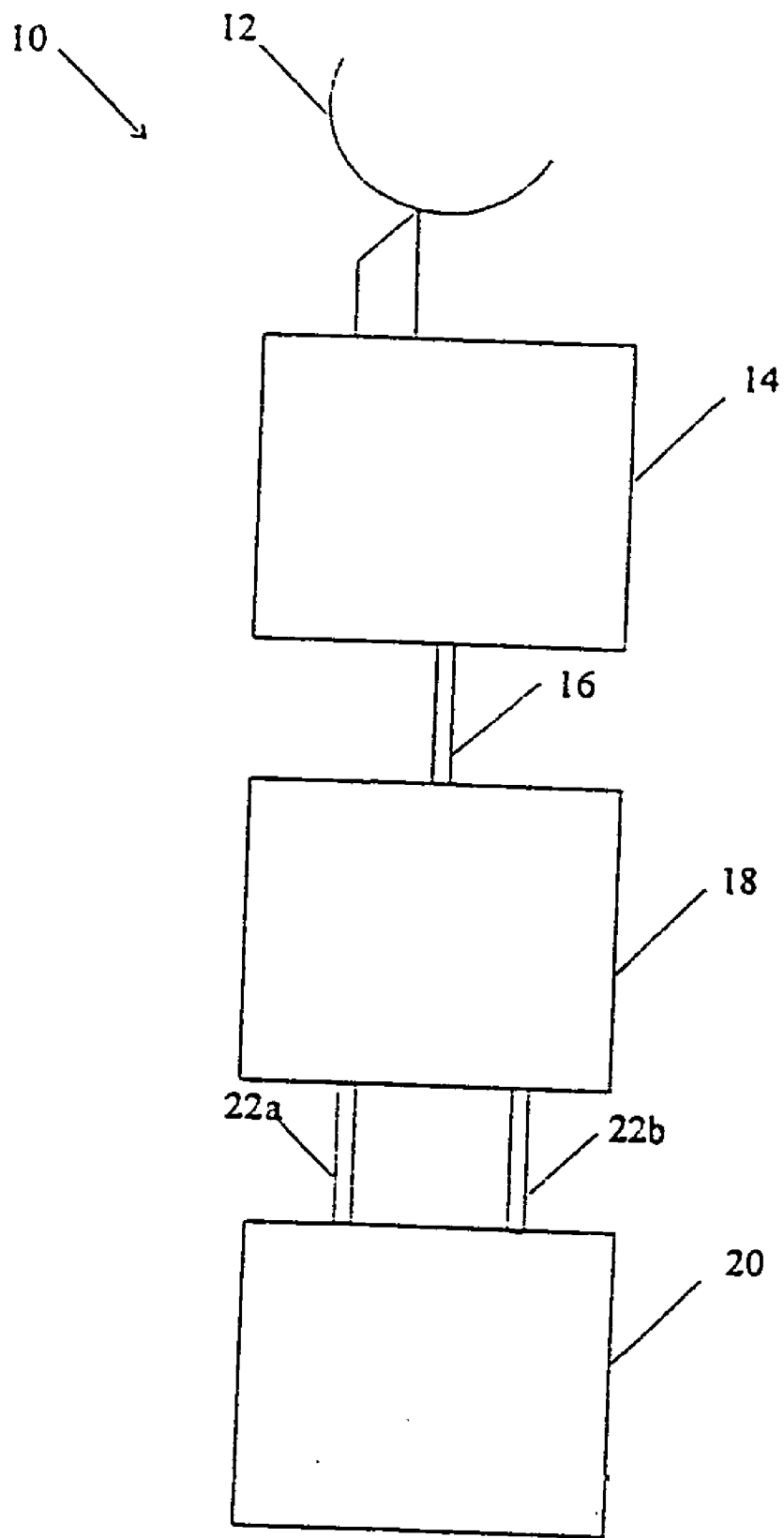

Figure 1

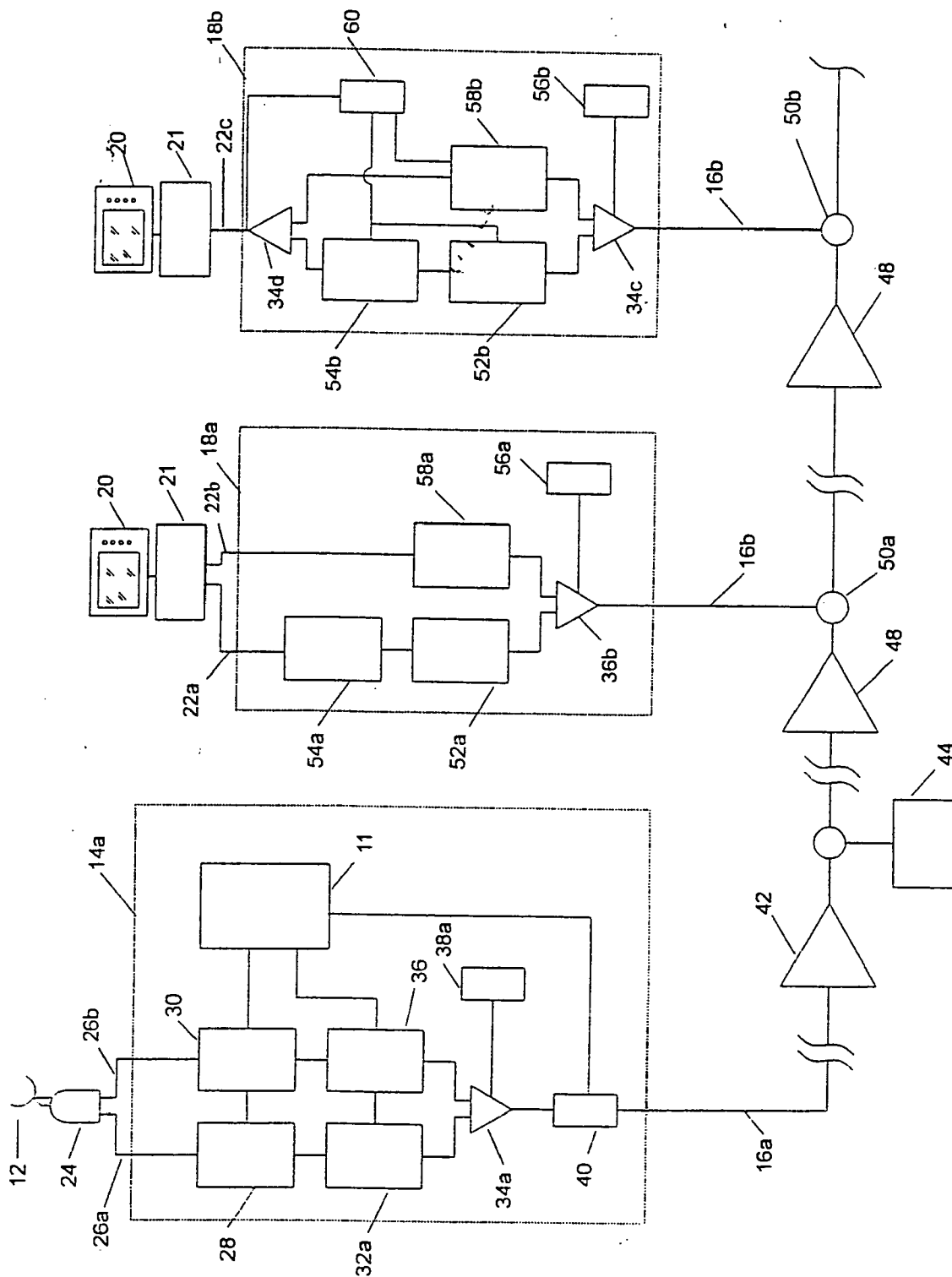

Figure 2

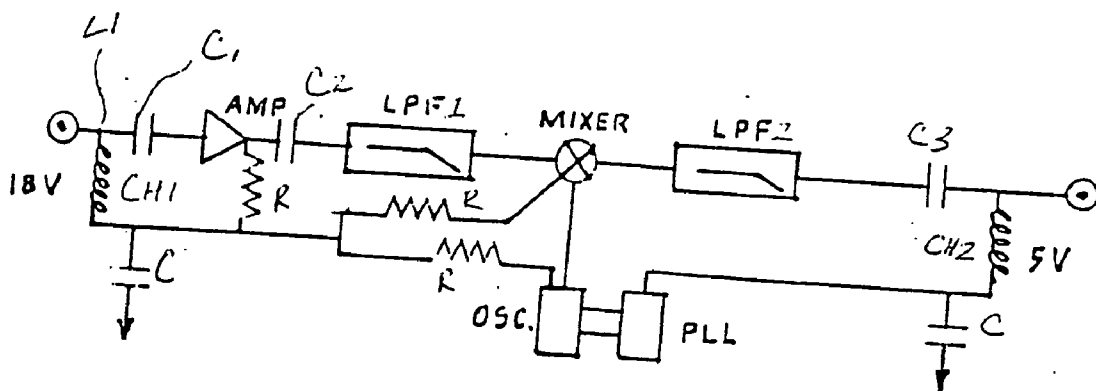

Fig. 3a

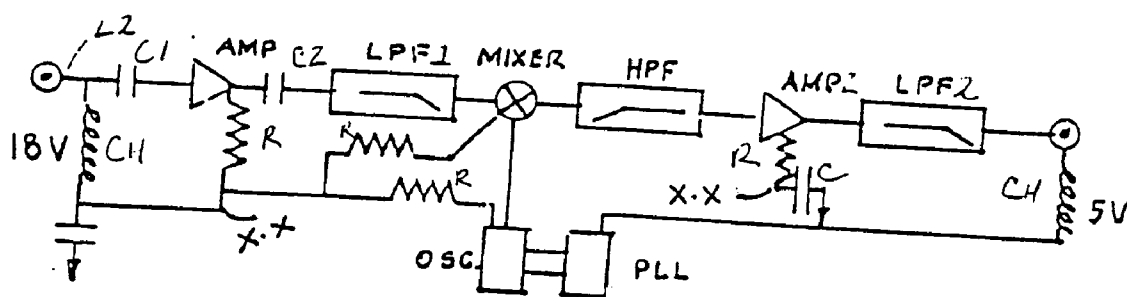

Fig. 3b

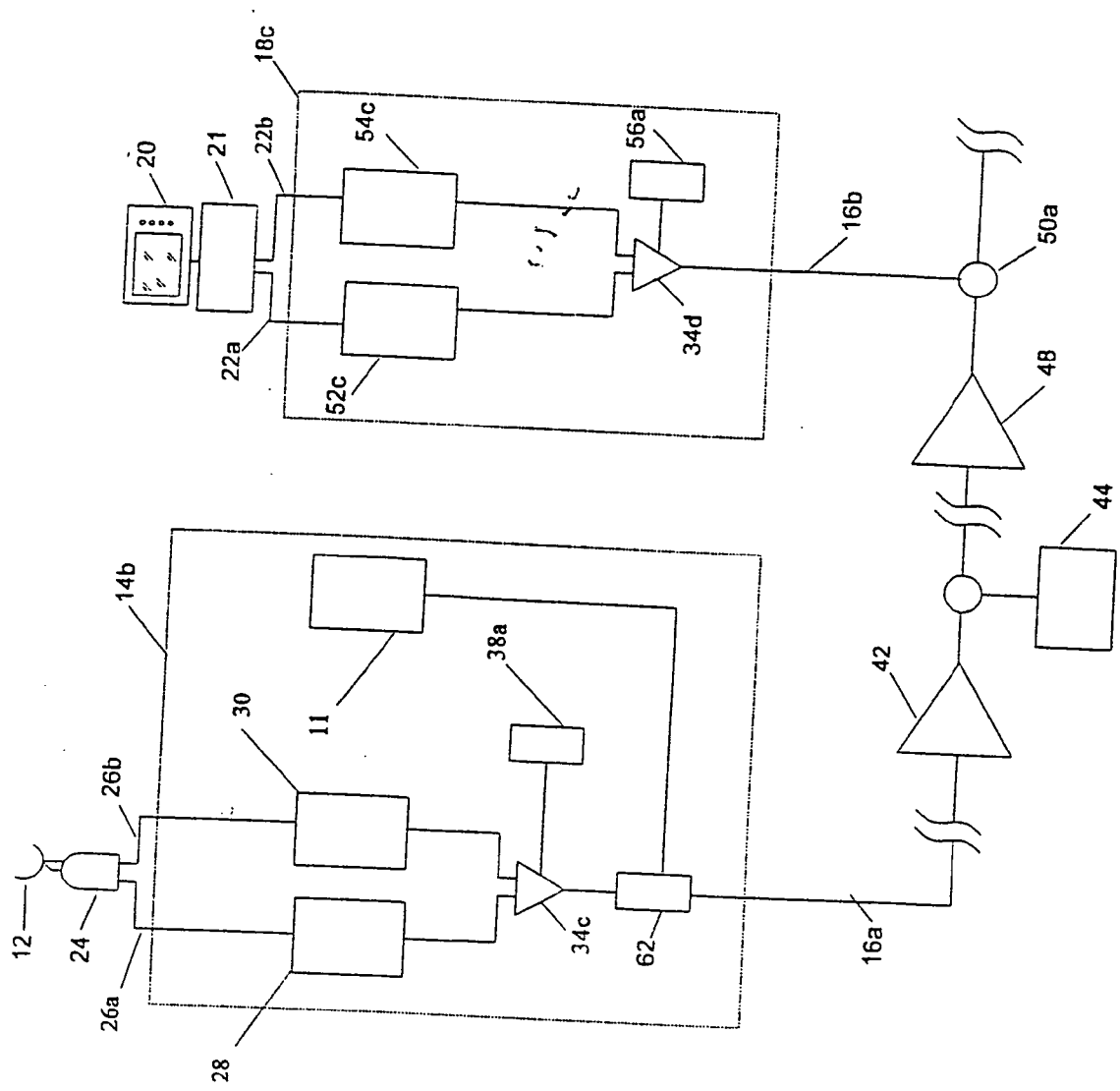

Figure 4

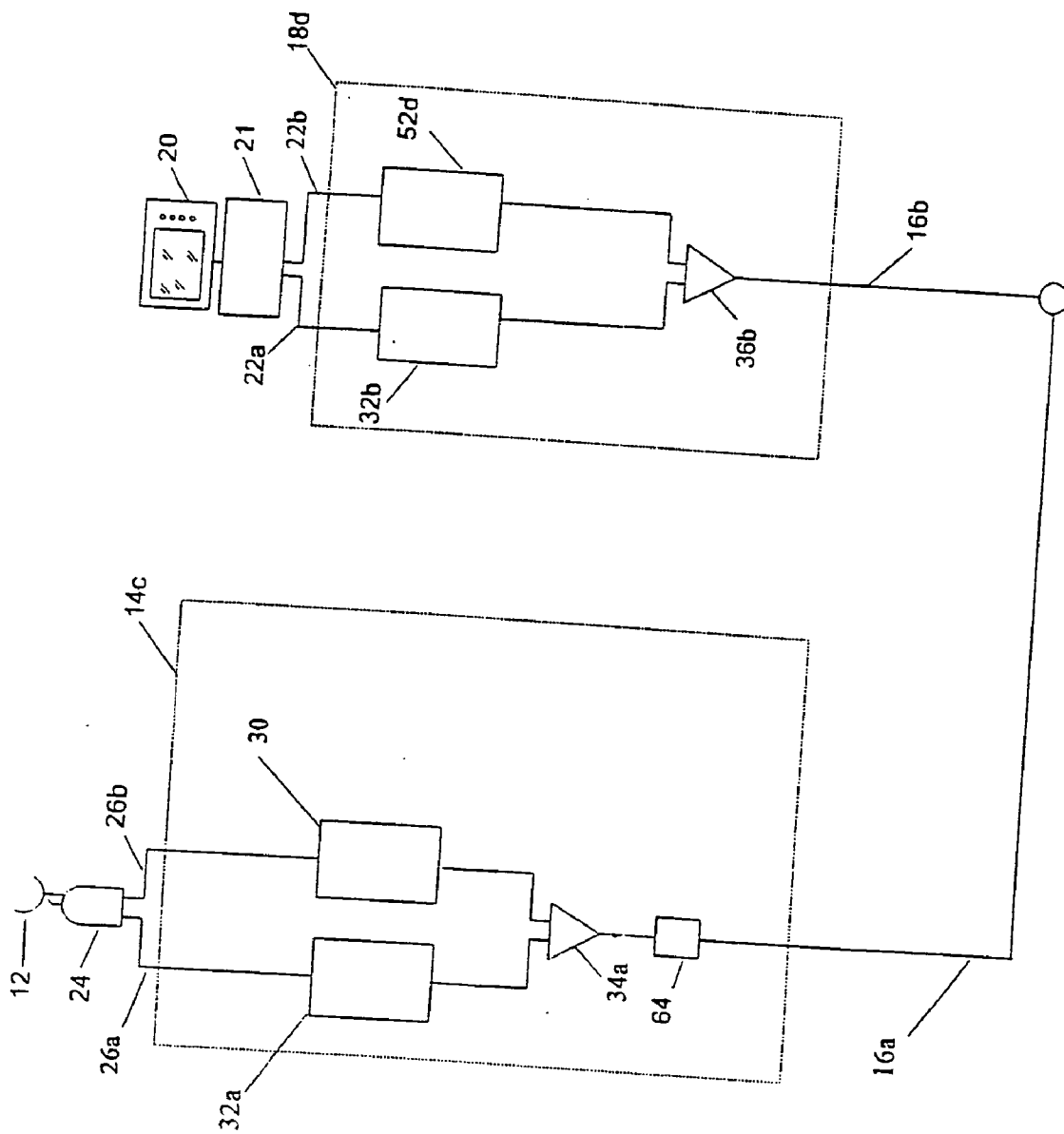

Figure 5

SATELLITE BROADCAST RECEIVING AND DISTRIBUTION SYSTEM

[0001] This is a Continuation-in-Part of Application No. 08/394,234.

BACKGROUND OF THE INVENTION

[0002] 1. Field of the Invention

[0003] The present invention relates generally to a satellite broadcasting receiving and distribution system and more particularly to a broadcasting receiving and distribution system that will allow for the transmission of vertical and horizontal or left-hand circular and right-hand circular polarization signals to be transmitted simultaneously via a single coaxial cable.

[0004] 2. Description of the Prior Art

[0005] Satellite broadcasting has become very popular throughout the United States. Conventionally, broadcast signals are transmitted through an artificial satellite at very high frequencies. These frequencies are generally amplified and are processed by a particular device after received by an antenna or antennas and prior to application to a conventional home television set or the like.

[0006] Typically, broadcasting systems comprises an outdoor unit generally associated with the antenna and an indoor unit generally associated with the television set or the like. Both units, indoor and outdoor, are coupled via a coaxial cable.

[0007] A problem associated with these types of systems is that they are designed to accept signals through a line of sight. Accordingly, if the satellite is not visible from a building, then the signal cannot be transmitted. Thus, these systems are rendered useless for high-rises, hospitals, schools, and the like. These systems are limited in usage, and as such, can only be utilized in residential homes.

[0008] As an example, U.S. Pat. No. 5,301,352 issued to Nakagawa et al. discloses a satellite broadcast receiving system. The system of Nakagawa et al. includes a plurality of antennas which, respectively, include a plurality of output terminals. A change-over divider is connected to the plurality of antennas and includes a plurality of output terminals. A plurality of receivers are attached to the change-over divider for selecting one of the antennas. Though this system does achieve one of its objects by providing for a simplified satellite system, it does, however, suffer a major shortcoming by not providing a means of receiving satellite broadcasting for individuals who are not in the direct line of sight to the antennas. This system is silent to the means of simultaneously transmitting vertical and horizontal polarized signals via a single coaxial cable.

[0009] U.S. Pat. No. 5,206,954, issued to Inoue et al. and U.S. Pat. No. 4,509,198 issued to Nagatomi both disclose yet another satellite system that includes an outdoor unit that is connected to a channel selector. In this embodiment, the satellite signal receiving apparatus receives vertically and horizontally polarized radiation signals at the side of a receiving antenna. The signals are then transmitted, selectively, to provide for either one of the vertically or horizontally polarized signals to be transferred. Hence, utilizing a switch only one polarity is transmitted. This design and configuration provides for one coaxial cable to be utilized,

but does not provide for the vertical and horizontal signals to be transmitted simultaneously rather selectively.

[0010] Systems have been attempted for transferring two frequencies on the same co-axial cable. Frequencies of the same polarity can easily be transmitted via a single co-axial cable, however, transmitting two signals, from two sources, each of different polarities can be a challenge. In some satellite configuration systems, once a timing diagram is plotted for the signals transmitted, it is seen that a forbidden path occurs between frequencies of 950 MHz and 1070 MHz. Inherently prohibiting the frequencies within that range to be transmitted successfully. Hence, it is desirable to obtain a system which will not allow for conversion to occur at frequencies of the forbidden conversion.

[0011] As seen in German Patent Number DE4126774-A1, signals can be transmitted within the range of the forbidden path, thereby, providing for a non-working system. Additionally, this product, like the assembly disclosed in Japanese Application No. 63-293399 both disclose a system which receives a single signal and demultiplexed them into vertical and horizontal polarized signals. These systems, are complex and require a numerous amount of components in order to employ the invention. This increase in components will inherently cause an increase in component failure. Further, these systems fail to disclose a means of reconverting the signals into their original frequency and polarity, a necessity for satellite systems. Consequently, providing a signal which will not maintain its respective polarity.

[0012] Accordingly, it is seen that none of these previous efforts provide the benefits intended with the present invention, such as providing a broadcasting receiving and distribution system that will allow for the transmission of vertical and horizontal or left-hand circular and right-hand circular polarization signals to be transmitted successfully and simultaneously via a single coaxial cable. Additionally, prior techniques do not suggest the present inventive combination of component elements as disclosed and claimed herein. The present invention achieves its intended purposes, objectives and advantages over the prior art device through a new, useful and unobvious combination of component elements, which is simple to use, with the utilization of a minimum number of functioning parts, at a reasonable cost to manufacture, assemble, test and by employing only readily available material.

SUMMARY OF THE INVENTION

[0013] The present invention provides a satellite broadcast receiving and distribution system that will permit for the transmission of vertical and horizontal or left-hand circular and right-hand circular polarization signals simultaneously via a single coaxial cable. The system of the present invention will accommodate two different polarity commands from two or more different sources at the same time. This satellite broadcast receiving and distribution system of the present invention will provide for the signals received from the satellite to be converted to standard frequencies so as to permit for signals to travel via existing wiring which the present day amplifiers can transport in buildings, high-rises, hospitals, and the like so that satellite broadcasting can be viewed by numerous individuals by way of a single satellite antenna.

[0014] The satellite broadcast system of the present invention comprises a satellite antenna which receives the polarized signals, a head-in frequency processor for converting the polarized signals, a single co-axial cable for transmitting the converted signal, a head-out receiver processor for re-converting the signals to their original frequency and polarity, and a source, which receives the signals in their respective original frequency and polarity. Structurally, the head-in frequency processor is coupled to the head-out receiver processor via the single co-axial cable. The source is coupled to the head-out receiver processor.

[0015] Hence, to allow for successful conversion, the head-in processor converts the received signals of two different polarities to frequencies which permit for transmission simultaneously. The head-in processor will also accommodate two different polarity commands from two or more different sources at the same time via the single cable.

[0016] The single cable couples the head-in processor to the head-out processor. Once in the head-out processor, the signals are re-converted to their original state for transmission to the source (i.e. television).

[0017] Accordingly, it is the object of the present invention to provide for a satellite broadcast receiving and distribution system which will overcome the deficiencies, shortcomings, and drawbacks of prior satellite broadcast systems and signal and polarity transfer methods.

[0018] It is another object of the present invention to provide for a satellite broadcast receiving and distribution system that will convert different frequencies and different polarized signals in order to permit the signal to be transmitted via a single coaxial cable.

[0019] Another object of the present invention is to provide for a satellite broadcast receiving and distribution system that will provide service to mid/high-rise office buildings, condominiums, schools, hospitals and the like via a single satellite.

[0020] Still another object of the present invention, to be specifically enumerated herein, is to provide a satellite broadcast receiving and distribution system in accordance with the preceding objects and which will conform to conventional forms of manufacture, be of simple construction and easy to use so as to provide a system that would be economically feasible, long lasting and relatively trouble free in operation.

[0021] Although there have been many inventions related to satellite broadcast receiving and distribution systems, none of the inventions have become sufficiently compact, low cost, and reliable enough to become commonly used. The present invention meets the requirements of the simplified design, compact size, low initial cost, low operating cost, ease of installation and maintainability, and minimal amount of training to successfully employ the invention.

[0022] The foregoing has outlined some of the more pertinent objects of the invention. These objects should be construed to be merely illustrative of some of the more prominent features and application of the intended invention. Many other beneficial results can be obtained by applying the disclosed invention in a different manner or modifying the invention within the scope of the disclosure. Accordingly, a fuller understanding of the invention may be

had by referring to the detailed description of the preferred embodiments in addition to the scope of the invention defined by the claims taken in conjunction with the accompanying drawings.

BRIEF DESCRIPTION OF THE DRAWINGS

[0023] FIG. 1 is a block diagram illustrating the components used for the satellite broadcast receiving and distribution system according to the present invention.

[0024] FIG. 2 is a block diagram representing a first embodiment of the head-in frequency processor and two embodiments of the head-out frequency processor used for the satellite broadcast receiving and distribution system according to the present invention.

[0025] FIG. 3a is a schematic diagram of the down converter used for the satellite broadcast signal receiving and distribution system according to the present invention.

[0026] FIG. 3b is a schematic diagram of the up converter used for the satellite broadcast signal receiving and distribution system according to the present invention.

[0027] FIG. 4 is a block diagram of the second embodiment of the satellite broadcast signal receiving and distribution system according to the present invention.

[0028] FIG. 5 is a block diagram of the third embodiment of the satellite broadcast signal receiving and distribution system according to the present invention.

[0029] Similar reference numerals refer to similar parts throughout the several views of the drawings.

DESCRIPTION OF THE PREFERRED EMBODIMENTS

[0030] As illustrated in FIG. 1, the satellite system 10 of the present invention includes a receiving satellite 12 that will transmit signals (Vertical-polarized signals and Horizontal-polarized signals or left-hand circular and right-hand circular polarization signals) to a head-in equipment frequency processor 14. It is at this head-in equipment frequency processor 14 where the signals are received simultaneously and then transmitted via a single coaxial cable 16 to the head-out receiver processor 18. This will enable for the single coaxial cable 16 to transmit signals of two different polarities and frequencies simultaneously. From the head-out frequency processor the signals are reconverted to its original state and then transmitted to a source 20. As seen in FIG. 1, the two different polarities (Vertical-polarized signals and Horizontal-polarized signals or left-hand circular and right-hand circular polarization signals) are transported to the source via separate cables 22a and 22b, respectively.

[0031] The system of the present invention includes separate embodiments, and the first embodiment is illustrated in FIG. 2. As seen in the first embodiment of the present invention 10a, there is shown a head-in frequency processor 14a couple to either a first head-out frequency processor 18a or a second head-out frequency processor 18b.

[0032] It is noted that FIG. 2 illustrated the head-in processor 14a to be coupled to two separate head-out processors 18a and 18b, respectively. This is shown for illustrative purposes only. In actuality, only one head-out

receiver processor is utilized with the head-in processor **14a**. The type and embodiment used for the head-out receiver processor is dependent to the combination of the satellite receiver and source that is utilized.

[0033] As seen in **FIG. 2**, the head-in equipment frequency processor **14a** will receive two signals or two separate polarities and converted them to separate frequencies for enabling transmission via a single coaxial cable **16b**.

[0034] A low-noise block converter (LNB) **24** will receive the signals from the satellite **12**. This LNB **24** is conventional and is used for amplifying the respective polarized signals (Vertical-polarized signals and Horizontal-polarized signals or left-hand circular and right-hand circular polarization signals). Accordingly, after signals are received, they pass the low-noise block converter **24**, to provide for the signals to enter the head-in equipment frequency processor **14a** (illustrated in **FIG. 2** as dashed lines) via conduits **26a** and **26b**, respectively.

[0035] The head-in equipment frequency processor **14a**, illustrated in **FIG. 2**, provides for the signals to be converted, via converters **28** and **30**, to the frequencies which the present day amplifiers can transport. In this stage of the system, the object is to convert the signals of one polarity up (via converter **30**) and to convert the signals of second polarization down (via converter **28**). This will render the converted signals to be transmitted without emerging into the forbidden frequency conversion.

[0036] From the conduits **26a** and **26b**, the signals are transmitted to a first converter or down converter **28** and a second converter or up converter **30**. These frequency converters, **28** and **30**, respectively, convert the entered frequencies to a frequency which present day amplifiers can transport. The converters will be discussed in further detail in **FIGS. 3a** and **3b**. The utilization of two converters permit for the acceptance of two signals or polarized transponders that are of a different frequency.

[0037] In the down converting means **28**, the transponder is converted down to a specified frequency. The specified frequency is the frequency that is required for the present day amplifiers for transportation. The newly converted frequencies are amplified through the amplifying means **32a**. At means **32**, the converted frequencies are amplified so not to create second harmonics. These signals are then transferred to a conventional four way splitter **34a**.

[0038] In the up converting means **30**, the transponders are converted up to a specified frequency. The converted frequencies then are converted down via a down converter **36**. This process of converting up and then down provides for frequencies to be converted without difficulties and avoiding the forbidden conversion area.

[0039] The converted signals are transferred to the four way splitter **34a** in order to combine the frequency of the amplified signal of **32a** and frequency from converter **36**. To synchronized the system, the frequencies from the phase lock loop (PLL) transmitter **38a** are transmitted to the splitter **34a**.

[0040] From the splitter **34a**, the signals are passed through an AC power separator **40** which routes 60 Volts power to a DC power supply of 18 Volts. This will permit for the dual frequencies from the satellite dish **12** to be trans-

mitted simultaneously via a single coaxial cable **16b**. Dependent upon the length of the cable, an optional conventional amplifier **42** can be coupled thereto. Power from a power source **44** is inserted into the lines via a power inserter **46**. The signals are amplified, as need, with additional amplifiers **48**. It is noted that the amplifiers are optional and are dependent to the distance that the head-in frequency processor **14a** is located from the head-out frequency processor **18a** or **1b**. The power supply and power source **11** energize the head-in frequency processor **14a**.

[0041] From the single coaxial cable **16b**, the signals are adjusted via a tap **50a** to permit for the appropriate decibels that are required for the head-out processor **18a** or **18b**.

[0042] The head-out frequency processor used for the head-in processor **14a** illustrated in **FIG. 1**, can include two embodiments, dependent upon the embodiment for the source in combination with the satellite receiver.

[0043] The first embodiment for the head-out frequency processor is illustrated in **FIG. 2** by way of dash line **18a**. As seen in this embodiment, the simultaneously transmitted signals enter the processor via conduit **16b**. The conduit **16b** is coupled to a conventional four (4) way splitter **34b**. A conventional phase lock loop (PLL) receiver **56a** is coupled to the splitter **34a** to permit for the signals to be locked to the proper and desired frequencies. From the splitter **34b** the first frequency is transmitted to a first converter **58a** in order to permit for the signals or transponders to be converted up to a specified frequency. This up converted signal from the first converter or up converter **58a** is then transmitted to the satellite receiver by way of a conduit **22b**.

[0044] The second frequencies are transmitted to a first or up converter **52a** and then are transmuted to a second or down converter **54a**. This will permit for the signals to be converted to the desired frequency. This second or down converter is coupled to the satellite receiver **21** via conduit **22a**. The signals from down converter **54a** and from up converter **58a** are in the original state, both frequency and polarity, when transmitted from the satellite to the head-in processor **14a**, via lines **26a** and **26b**. The re-converted signals, frequencies and polarity in its original state, is transmitted to the satellite receiver **21** via lines **22a** and **22b**. The satellite receiver **21** is coupled to a source **20** (illustrated as a television) to provide for proper transmission of the signals. The transmission line between the satellite receiver **21** and source **20** is illustrated but not labeled.

[0045] Hence, it is seen that the head-in processor converted the signals to different frequency to enable the transmission of two separate polarized signals via a single co-axial cable to a head-out processor. From the head-out processor, the signals are re-converted to their original state, which was received via lines **26a** and **26b**. For example, with satellite systems, frequencies typically range between 950-1450 MHz. If the satellite transmits a frequency of 1450 for both the horizontal and vertical polarities, then one of the polarities, such as horizontal, is converted down to 560 MHz via converter **28**. The second frequency of the second polarity, such as vertical, is first converted up to 2010 and then back down to 1070, via converters **30** and **36**, respectively. Such a conversion allows for the two frequencies of two different polarities, 560 MHz (horizontal) and 1070 MHz (vertical), to be transmitted simultaneously on a single co-axial cable (**16b**).

[0046] As illustrated, this head-out frequency processor is the reverse process of the head-in processor. This is to provide for the signals to reconverted to its original frequencies so as to provide for the satellite receiver **21** and source **20** to accept the signals. The single cable **16b** accepts the signals at frequencies different than that of the source. Accordingly, the head-out processor must re-convert the signals to the frequencies that are utilized by the source **20**.

[0047] An alteration of the satellite receiver requires an alteration in the head-out receiver processor. This alteration is illustrated in **FIG. 2** and is shown in outline designated as reference **18b**. In this design and configuration, the satellite receiver utilizes only one wire and accepts only one type of signals, selectively, such as only left-hand circular or only right hand circular polarized signals.

[0048] As seen, the frequencies are tapped via **50b**. The tap **50b** is coupled to the head-out processor **18b** via line **16b** which is connected to a four (4) way splitter **34c**. To provide for the signals to be locked in proper frequencies, the four way splitter is coupled to a phase lock loop (PLL) receiver **56b**.

[0049] From the splitter **34c**, the first signal of a first polarity is transmitted to a first or up converted **52b** and then is transmitted to a second or down converter **54b**. The conversion of the signals from up to down provides the benefit of converting the frequency without any mishap or error. This method of conversion will avoid the forbidden conversion area as well as provide for the original received frequency and polarity of the signals.

[0050] The signals of the second frequency and second polarity are transmitted to an up converter **58b** which will inherently convert the signals to its original received frequency while maintaining its polarity. A polarity switch **60** is connected to converters **52b**, **54b**, and **58b** for coupling the head-out processor to the satellite receiver via a single cable **22c** and a joining means, which is a four way splitter **34d**. The satellite receiver **21** is connected by way of a line (illustrated, but not labeled) to a source **20**. In this embodiment, the switch **60** is used to determine which polarity will enter into the head-out processor **18b**.

[0051] In the embodiments shown above, the satellite receiver **21** and source **20** are conventional components and as such, their schematics are not shown in further detail. The up and down converters used in the embodiment above will be discussed in further detail in **FIG. 3a** and **FIG. 3b**. **FIG. 3a** represents the schematic rendering of the down converters (**28**, **36**, **54a**, and **54b**) and **FIG. 3b** represents the schematic rendering of the up converters (**30**, **52a**, **52b**, **58a**, and **56b**).

[0052] As seen in the schematic diagram of **FIG. 3a**, the signal enters the down converter via line **L1**. The entered signal passes through a first capacitor **C1** which is coupled to an amplifier **AMP**. After passing the amplifier **AMP**, the signal passes a second capacitor **C2** before entering a first low pass filter **LPF1**. This first **LPF1** is coupled to a mixer which is coupled to a second **LPF2**. This second **LPF2** is connected to a third capacitor **C3** which is coupled to a second choke **CH2**. The mixer is also connected to an oscillator **OSC**. The oscillator is coupled to a **PLL**. The first capacitor **C1** is also connect to a first choke **CH2**. Capacitors **C** are coupled to the amplifier, oscillator, phase lock lobe

PPL, and the second low pass filter. Resistors **R** are coupled to the amplifier, oscillator, first low pass filter and mixer. Chokes are also coupled in series with capacitors **C** to provide for the chokes to be parallel with the amplifier **AMP** and the second low pass filter, respectively. As seen the chokes **CH1** and **CH2** (inductors) and capacitors **C** are a DC bypass filter network and provide a DC path and enables passing DC power to the antenna electronics.

[0053] The up converter is disclosed in **FIG. 3b**. As seen in this drawings, the signal enters the up converter via a first line **L2**. The converter further includes an amplifier **AMP** that is coupled to a first low pass filter **LPF1**. The amplifier is also coupled to an oscillator **OSC**. The oscillator and the first low pass filter are connect to a mixer. This mixer is coupled to a high pass filter **HPF**. The oscillator is also connected with a phase lock loop receiver **PLL**. A second amplifier **AMP2** is coupled to the high pass filter **HPF**. A second low pass filter **LPF2** is coupled to the second amplifier. Capacitors **C** are coupled to the first amplifier, first lower pass filter, and a the amplifier. Resistors **R** are coupled other first and second amplifiers, oscillator, first low pass filter, and mixer. Chokes are also used in this circuit. The first choke is coupled to a capacitor which is coupled to the first amplifier. The second chock is coupled to the phase lock loop.

[0054] Simplifying the system described above, will provide a second embodiment for the satellite broadcast receiving and distribution system. This second system is illustrated in further detail in **FIG. 4**. This embodiment simplifies the above describe embodiment and also provides a device which avoids the forbidden path. Alteration for this embodiment occurs in the head-in equipment frequency processor **14b** and the head-out frequency processor **18c**.

[0055] As with the first embodiment, a low-noise block converter (LNB) **24** will receive the signals from the satellite **12**. This LNB **24**, as stated previously is conventional and is used for amplifying the respective polarized signals (Vertical-polarized signals and Horizontal-polarized signals or left-hand circular and right-hand circular polarization signals). Hence, after signals are received, they pass the low-noise block converter **24**, to provide for the signals to enter the head-in equipment frequency processor **14b** (illustrated in **FIG. 4** as dashed lines) via conduits **26a** and **26b**, respectively.

[0056] The head-in equipment frequency processor **14e** provides for the signals to be converted, via converters **28** and **30**, as identified for the first embodiment. Thereby providing a system which includes frequencies that the present day amplifiers can transport. In this stage of the system, the object is to convert the signals of one polarity up (via converter **30**) and to convert the signals of second polarization down (via converter **28**).

[0057] From the conduits **26a** and **26b**, the signals are transmitted to a first converter or down converter **28** and a second converter or up converter **30**. These frequency converters, **28** and **30**, respectively, convert the entered frequencies to a frequency which present day amplifiers can transport. The converters have been discussed in further detail in **FIGS. 3a** and **3b**. The utilization of two converters permit for the acceptance of two signals or polarized transponders that are of a different frequency.

[0058] In the down converting means **28**, the transponder is converted down to a specified frequency. The specified

frequency is the frequency that is required for the present day amplifiers for transportation. Though not illustrated, the newly converted frequencies are amplified through the amplifying means, as illustrated in FIG. 2 via element 32a. At the amplifying means 32, the converted frequencies are amplified so not to create second harmonics. These signals are then transferred to a conventional two way splitter 34c.

[0059] In the up converting means 30, the transponders are converted up to a specified frequency. The converted signals are transferred to the two-way splitter 34c in order to combine the frequency of the amplified signal and frequency. To synchronized the system, the frequencies from the phase lock loop (PLL) transmitter 38a are transmitted to the splitter 34c.

[0060] From the splitter 34c, the signals are passed through a conventional tilt and gain 62. This will permit for the dual frequencies from the satellite dish 12 to be transmitted simultaneously via a single coaxial cable 16b. Dependent upon the length of the cable, an optional conventional amplifier 42 can be coupled thereto. Power from a power source 44 is inserted into the lines via a power inserter 46. The signals are amplified, as needed, with additional amplifiers 48. It is noted that the amplifiers are optional and are dependent to the distance that the head-in frequency processor 14b is located from the head-out frequency processor 14c. The power supply and power source 11 energize the head-in frequency processor 14a.

[0061] From the single coaxial cable 16b, the signals are adjusted via a tap 50a to permit for the appropriate decibels that are required for the head-out processor 18a or 18b.

[0062] The head-out frequency processor used for the head-in processor 14b is illustrated in by way of dash line 18c. As seen in this embodiment, the simultaneously transmitted signals enter the processor via conduit 16b. The conduit 16b is coupled to a conventional two (2) way splitter 34d. A conventional phase lock loop (PLL) receiver 56a is coupled to the splitter 34d to permit for the signals to be locked to the proper and desired frequencies. From the splitter 34d the first frequency is transmitted to a first converter 52c in order to permit for the signals or transponders to be converted up to a specified frequency. This up converted signal from the first converter or up converter 52c is then transmitted to the satellite receiver by way of a conduit 22a.

[0063] The second frequencies are transmitted to a down converter 54c. This will permit for the signals to be converted to the desired frequency. This second or down converter is coupled to the satellite receiver 21 via conduit 22b. The signals from down converter 54c and from up converter 52c are in the original state, both frequency and polarity, when transmitted from the satellite to the head-in processor 14b, via lines 26a and 26b. The re-converted signals, frequencies and polarity in its original state, is transmitted to the satellite receiver 21 via lines 22a and 22b. The satellite receiver 21 is coupled to a source 20 (illustrated as a television) to provide for proper transmission of the signals. The transmission line between the satellite receiver 21 and source 20 is illustrated but not labeled.

[0064] Hence, it is seen that the head-in processor converted the signals to different frequency to enable the transmission of two separate polarized signals via a single

co-axial cable to a head-out processor. From the head-out processor, the signals are re-converted to their original state, which was received via lines 26a and 26b. The above identified embodiment is ideal for long distant use, i.e. exceeding 1000 feet. However, for shorter distance, i.e. less than 1000 feet, the components can be simplified again to provide for a device which is ideal for use in apartments or the like.

[0065] As seen in FIG. 5, the present invention includes the head-in equipment frequency processor 14c and the head-out frequency processor 18d.

[0066] As with the first and second embodiments, a low-noise block converter (LNB) 24 will receive the signals from the satellite 12. This LNB 24, as stated previously, is conventional and is used for amplifying the respective polarized signals (Vertical-polarized signals and Horizontal-polarized signals or left-hand circular and right-hand circular polarization signals). Hence, after signals are received, they pass the low-noise block converter 24, to provide for the signals to enter the head-in equipment frequency processor 14c (illustrated in FIG. 5 as dashed lines) via conduits 26a and 26b, respectively.

[0067] As seen, this head-in equipment frequency processor 14c is simplified. The head-in equipment frequency processor 14c, provides for signals of one frequency to be converted, up via converter 30, as identified for the first embodiment. Thereby providing a system which includes frequencies that the present day amplifiers can transport. In this stage of the system, the object is to convert the signals of one polarity up (via converter 36). The signal of the second polarity is amplified via conventional amplifier 32a.

[0068] From the conduits 26a and 26b, the signals are transmitted to a first converter or down converter 52d and a amplifier 32a. The down converters have been discussed in further detail in FIG. 3a.

[0069] From the amplifier and up converter, the signals are transferred to a conventional hybrid mixer 34a. From the mixer, the signals pass a diplexer. Exiting the diplexer can occur via a single co-axial cable 16a.

[0070] From the single coaxial cable 16a, the signals can be adjusted via a tap (illustrated, but not labeled) to permit for the appropriate decibels that are required for the head-out processor 18d.

[0071] The head-out frequency processor used for the head-in processor 14c is illustrated in by way of dash line 18d. As seen in this embodiment, the simultaneously transmitted signals enter the processor via conduit 16b. The conduit 16b is coupled to a conventional mixer 36b to the proper and desired frequencies. From the mixer 36b the first frequency is transmitted to an amplifier 32b and the second frequency of a different polarity is transferred to a down converter 52d for converting the frequency to its original state.

[0072] The re-converted signals, frequencies and polarity in its original state, is transmitted to the satellite receiver 21 via lines 22a and 22b. The satellite receiver 21 is coupled to a source 20 (illustrated as a television) to provide for proper transmission of the signals. The transmission line between the satellite receiver 21 and source 20 is illustrated but not labeled.

[0073] Hence, it is seen that the head-in processor converted the signals to different frequency to enable the transmission of two separate polarized signals via a single co-axial cable to a head-out processor. From the head-out processor, the signals are re-converted to their original state, which was received via lines 26a and 26b. The above

[0074] The satellite system of the present invention will permit for two signals of different frequency and polarities to travel simultaneously via a single coaxial cable. The use of this will provide for a satellite system that is versatile, economical and compact. The usage of the single cable permits for a system that can accept satellite broadcasting in places that were previously render impossible. These places include mid/high-rise office buildings, condominiums, hospitals, schools, etc. The unique design and configuration enables the signals to be transmitted via the existing wiring of the buildings. The only renovations that may need to be done is the upgrading of the existing amplifiers.

[0075] While the invention has been particularly shown and described with reference to an embodiment thereof, it will be understood by those skilled in the art that various changes in form and detail may be made without departing from the spirit and scope of the invention.

We claim:

1. A satellite broadcasting system comprising:

a satellite dish coupled to a low-noise block converter;

said low-noise block converter is coupled to a first means of converting vertical polarization signals and horizontal polarization signals or left-hand circular polarization signals and right-hand circular polarization signals from a satellite and transmitting simultaneously via a single coaxial cable for enabling two

different frequencies and polarities to be transmitted simultaneously via said single coaxial cable;

a second means is coupled to said first means;

said second means converts said vertical polarization signals and said horizontal polarization signals or said left-hand circular polarization signals and said right-hand circular polarization signals from said first means to its original received state from said satellite dish;

a satellite receiver is coupled to said second means; and said source is coupled to said satellite receiver.

2. A satellite system as in claim 1 wherein a power source is coupled to said first means and said power source powers said first means.

3. A satellite system as in claim 1 wherein said second means provides for said signals to be converted separately and independently to said satellite receiver by a transmitting means.

4. A satellite system as in claim 1 wherein said second means provides for a transmitting means for said signals to be selectively converted to said satellite receiver via a first cable coupled to said second means.

5. A satellite system as in claim 4 wherein said transmitting means further includes a polarity switch for permitting said signals to be selectively converted to said satellite receiver.

6. A satellite system as in claim 1 wherein said first means includes a first converting system for converting said signals of a first direction to a desired first frequency and polarization and a second converting system for converting said signals of a second direction to a desired second frequency and polarization.

* * * * *