



INTERNATIONAL APPLICATION PUBLISHED UNDER THE PATENT COOPERATION TREATY (PCT)

<p>(51) International Patent Classification ⁵ : G09F 3/00</p>	<p>A1</p>	<p>(11) International Publication Number: WO 93/23838 (43) International Publication Date: 25 November 1993 (25.11.93)</p>
<p>(21) International Application Number: PCT/US93/04772 (22) International Filing Date: 19 May 1993 (19.05.93) (30) Priority data: 07/886,985 21 May 1992 (21.05.92) US (71)(72) Applicant and Inventor: WILLIAMSON, Roger, L. [US/US]; 6821 Avenida de Santiago, Anaheim, CA 92807 (US). (74) Agents: SIMPSON, Andrew, H. et al.; Knobbe, Martens, Olson & Bear, 620 Newport Center Drive, 16th Floor, Newport Beach, CA 92660 (US).</p>		<p>(81) Designated States: AT, AU, BB, BG, BR, BY, CA, CH, CZ, DE, DK, ES, FI, GB, HU, JP, KP, KR, KZ, LK, LU, MG, MN, MW, NL, NO, NZ, PL, PT, RO, RU, SD, SE, SK, UA, VN, European patent (AT, BE, CH, DE, DK, ES, FR, GB, GR, IE, IT, LU, MC, NL, PT, SE), OAPI patent (BF, BJ, CF, CG, CI, CM, GA, GN, ML, MR, NE, SN, TD, TG).</p> <p>Published <i>With international search report. Before the expiration of the time limit for amending the claims and to be republished in the event of the receipt of amendments.</i></p>

(54) Title: SKI POLE TRAIL MAP HOLDER

(57) Abstract

A ski area trail map holder is provided for use with a ski pole. In one form, the holder comprises a tubular housing (22) having a spring biased roller (26) therein. The housing is attachable to the ski pole (20) at any point along the pole. The ski area trail map (82) is releasably secured to a map cover (28) which is extendable from a retracted position in which it is rolled on the roller, to an extended position in which it is outside of the housing. The map cover comprises two transparent sheets (70a, 70b), each of which is attached at one end to the roller and each of which has a free end located outside of the housing. A locking mechanism (91) is provided for securing the map cover and/or map in an extended position. In a second embodiment, the ski pole (120) itself acts as the outer housing for the map holder.

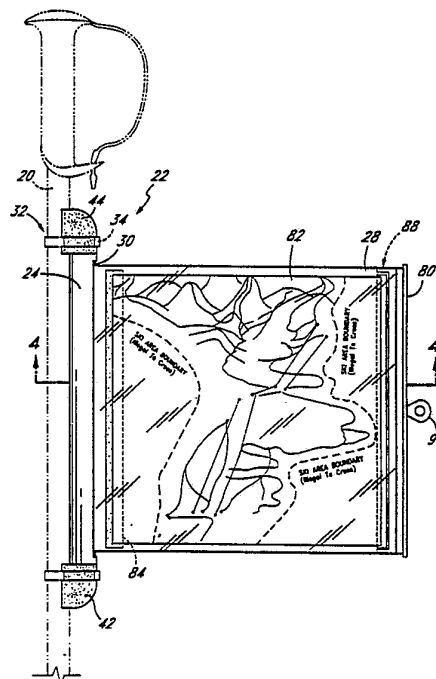

FOR THE PURPOSES OF INFORMATION ONLY

Codes used to identify States party to the PCT on the front pages of pamphlets publishing international applications under the PCT.

AT	Austria	FR	France	MR	Mauritania
AU	Australia	GA	Gabon	MW	Malawi
BB	Barbados	GB	United Kingdom	NL	Netherlands
BE	Belgium	GN	Guinea	NO	Norway
BF	Burkina Faso	GR	Greece	NZ	New Zealand
BG	Bulgaria	HU	Hungary	PL	Poland
BJ	Benin	IE	Ireland	PT	Portugal
BR	Brazil	IT	Italy	RO	Romania
CA	Canada	JP	Japan	RU	Russian Federation
CF	Central African Republic	KP	Democratic People's Republic of Korea	SD	Sudan
CG	Congo	KR	Republic of Korea	SE	Sweden
CH	Switzerland	KZ	Kazakhstan	SK	Slovak Republic
CI	Côte d'Ivoire	LI	Liechtenstein	SN	Senegal
CM	Cameroon	LK	Sri Lanka	SU	Soviet Union
CS	Czechoslovakia	LU	Luxembourg	TD	Chad
CZ	Czech Republic	MC	Monaco	TG	Togo
DE	Germany	MG	Madagascar	UA	Ukraine
DK	Denmark	ML	Mali	US	United States of America
ES	Spain	MN	Mongolia	VN	Viet Nam
FI	Finland				

SKI POLE TRAIL MAP HOLDERField of the Invention

The present invention relates to a map holder. More specifically, the invention relates to a ski area trail map holder for use with a ski pole.

Background of the Invention

Snow ski areas provide their customers with "ski area trail maps." These guide maps portray an overview of the ski area in drawing form. The maps normally depict the mountain or mountains comprising the ski area in outline form. Upon this outline is displayed various information. For example, the ski runs, or paths, which the skier may take are illustrated on the mountain outline. The ski lifts are also shown on the map. Other information, such as the level of difficulty of each run and the elevation at various points, is given. Further, information is given as to the various services, such as food, restrooms, warming huts and the like, and the location of the same at the ski area. A skier who is unfamiliar with a ski area relies heavily upon the information contained on these ski area trail maps. This information allows the skier to guide him or herself through the various runs to the base of the mountain and to the various lift and services. More importantly, the maps aid in providing skiers with information regarding the difficulty of the various runs, enabling the skier to chose runs which are within the level of their skiing ability, thus protecting them from injury.

The ski areas normally provide the trail maps in two forms. In one form, the maps are enlarged and stationed as "signs" at various locations around the ski area. These signs may be several feet wide and several feet tall. While these maps are large and easy to read, they have the disadvantage that in order to use them, they must first be located. Often a skier must ski out of a desired path in order to locate such a map. Further, because of the distance between the map signs, it is often the case that a skier becomes lost or otherwise misguided, and is in need of direction, before another map sign may be located.

Therefore, ski areas also offer ski area trail maps in individual sheet form to each skier. The maps are normally condensed into a size of about 16-20 inches in width by 10-20 inches in height (40-50 cm). The sheets typically have the ski area map on one side, along with advertisements or other information, and often have photos and various other information on the other side. The maps are prefolded so that they may be condensed to a size of about 4 inches (10 cm) by 4 inches (10 cm). In this form, the maps are easily transported by an individual skier in a pocket.

The individual maps are advantageous as they allow an individual skier to use them at any time and at any location. This permits, for example, the skier to plot out runs while riding the ski lift, or to stop at any location while skiing, in order to ascertain current location and/or plot a new course. However, these smaller folded maps also have certain disadvantages. Thus, in order to access and view the map, the map must normally be retrieved from a pocket by the skier and then unfolded for use. The map must then be refolded for storage. Often times, this process occurs while the user is riding a ski lift. To examine the map, the skier may have to stow his or her poles, and then remove one or more gloves in order to access the map from a pocket. This process often leads to a pole, glove, or other item being dropped by the skier from the lift into the snow below. Even if stopped on a run, a skier typically must remove one or more gloves and set poles down to access the map. Once accessed, the map, because it is made of paper, is often difficult to hold onto, especially when it is windy. The map may also quickly become water stained when unfolded and exposed to snow or sleet.

Summary of the Invention

In accordance with one aspect of the present invention, there is provided a ski pole trail map holder that advantageously allows a skier to selectively view a ski area trail map with ease and convenience. The holder of the present invention allows a skier to store an unfolded map on or in a ski pole, dispensing with the need to fold and unfold

maps for retrieval or storage in a pocket. Further, the holder of the present invention allows a user to quickly extend an already unfolded ski area trail map into a viewing position, and when done viewing, retract the map back into its protected, stored position. The mounting of the map to the ski pole provides a convenient location for storage and viewing of the ski area trail map, allowing a skier to access the map without the need to store his or her gloves or poles.

In one embodiment, the invention is a self contained tubular unit which is attached to the outside surface of a ski pole. In this form, the holder includes an outer tubular housing containing an inner spring roller mechanism. A ski area trail map is attached to the spring roller mechanism, allowing the ski area trail map to be rolled or unrolled from the roller through a longitudinal slot in the housing. The roller is spring biased so that the roller is resiliently urged in a direction in which the map connected thereto is rolled onto it.

The tubular map holder is connected to the outside of the ski pole with adjustable clamps. The clamps allow a skier to position the map holder in any position and at any point along the length of the ski pole, thus allowing the user to conveniently customize the position of the holder. Advantageously, the ends of the housing and the clamps are low in profile shaped to mate with the outside surface of the ski pole, in order that the holder may conform to the outside of the pole smoothly and without protrusions.

Preferably, the map is contained in a map cover which protects the map from the elements, as well as stations the map for easy viewing. The map cover is attached at one end to the roller, and extends out of the tubular housing through the longitudinal slot. The map cover includes two sheets of transparent, water resistant material, between which the ski area trail map may be inserted. The map cover thus protects the map from the elements, reducing the likelihood that the map may become water stained and unreadable.

Advantageously, the map cover allows a skier to securely

station a ski area trail map holder therein, and yet allows a skier to easily remove and replace a given ski area trail map. This feature is accomplished by a novel flap arrangement on the end of the map cover which extends from the housing. The flap arrangement allows the skier to releasably secure the two ends of the transparent sheets. Further, a small amount of reusable adhesive material located on the inside of the sheets near their connection with the roller aids in securely stationing the map. The secure stationing of the map insures that the map remains flat and easy to view when extended. Further, the cover aids in lessening the effect of wind upon the map when it is being viewed.

A handle is provided on the end of the map cover which extends from the housing. The handle allows a skier to easily grasp the map cover and map contained therein, and extend the map from the housing into a viewing position. This handle also serves to seal the slot through which the map is extended when the map is in its retracted position. Therefore, the handle prevents the entry of foreign material, such as snow, into the housing when the map is not being viewed. The handle is also designed so that the user need not remove his or her gloves in order to access the map, eliminating the worry that one or more gloves may be dropped and lost when an attempt is made to view the ski area trail map.

A lock is provided to allow the user to secure the position of the spring roller and map connected thereto. The lock is arranged such that the user may manually extend the map into a viewing position, and then easily secure the map in this position. This allows the user to ungrasp the handle when the map is in its viewing position, freeing the skiers hands. Further, a map may easily be replaced when the cover is in this extended, locked position.

In a second embodiment, the ski pole itself acts as the outer tubular housing, and the spring roller is mounted directly inside the ski pole itself. A longitudinal slot is placed in the pole to allow the extension of the ski area trail map as described above. The handle, lock, and map cover

are all as described above. This embodiment has the added advantage, however, of eliminating the mounting of a separate housing on the outside of the ski pole, keeping the ski pole in its single sleek form.

5 In either form of the invention, the map holder weighs less than about 7 ounces. In this manner, the holder does not have a noticeable effect on the ski pole onto or in which it is mounted.

10 Further objects, features and advantages of the present invention will become apparent from the detailed description of the drawings which follows, when considered with the attached figures.

Brief Description of the Drawings

15 Figure 1 is a perspective view of one embodiment of the map holder of the present invention attached to a ski pole.

Figure 2 is a perspective view of the map holder in Figure 1 with the map extended for viewing.

Figure 3 is an enlarged exploded cross-sectional view of the roller assembly and map housing.

20 Figure 4 is a cross-sectional view of the map holder taken along line 4-4 of Figure 2.

Figure 4a is an enlarged perspective view of the free end of the map cover in its extended position.

25 Figure 5 is a cross-sectional view of the map holder with the map retracted.

Figure 6 is a perspective view of an alternate embodiment map holder as mounted within a ski pole.

Figure 7 is a partial cut-away view of the map holder in Figure 6.

30 Figure 8 is a cross-sectional view of the map holder taken along line 8-8 of Figure 7, illustrating the lock in its locked position.

35 Figure 9 is a cross-sectional view of the map holder taken along line 8-8 of Figure 7, illustrating the lock in its unlocked position.

Detailed Description of the Illustrated Embodiment

Referring to FIGS. 1 and 2, there is shown one embodiment

of a map holder 22 of the present invention mounted to a ski pole 20. In general, the map holder 22 comprises an outer housing 24, containing an inner roller 26 and a map cover 28 for containing a ski area trail map 82 therein.

5 As illustrated in FIGS. 1 and 2, the map holder 22 comprises a tubular housing 24 for containing the map 82, the map holder 22 being attached to the outside of the ski pole 20. The map holder 22 of the present invention permits an unfolded ski area trail map 82 to be conveniently stored on a
10 ski pole (FIG. 1). The map holder 22 also allows a skier to easily extend the ski area trail map 82 from the housing 24 through a slot 30 therein into a viewing position (FIG. 2).

The map 82 is protected by the water resistant, transparent map cover 28 when extended from the housing 24 for
15 viewing, and by the map cover 28 and housing 24 when stored. The map cover 28 not only protects the map 82, but also secures the map 82 for viewing, preventing interference during viewing by wind and the like. A handle 90 is connected to the map holder 28 and allows a user to easily grasp the map cover
20 28 so as to extend the map 82 from within the housing 24 to a point outside thereof for viewing.

As now described in more detail, and as illustrated in FIG. 2, the outer housing 24 is an annular member which is preferably smooth on its outer surface, and as such, is
25 preferably a circular tube. The housing 24 is about 12 inches (30 cm) long, although the length may, of course, be longer or shorter depending on the particular pole 20 it is to be used with, and depending on the size of the map 82 to be housed. The inner diameter of the housing 24 is about 1.5 inches (3.4
30 cm), although the inner diameter may vary depending on the size of the map 82 which is desired to be housed and the map cover 28 material.

It is preferred that the housing 24 be made of plastic, formed by injection molding or other methods. Plastic is
35 preferred, since it retains strength and rigidity over a wide range of temperatures, and will not dent or crush in a fall, as metal might. Further, plastic is lightweight, corrosion

resistant, and may be formed in a variety of preselected colors. Although plastic is preferred, other materials having the necessary qualities stated above, are also suitable.

5 A slot 30 extends longitudinally nearly from end to end along the housing 24. The slot 30, as will be described in more detail below, allows passage of the map 82 in the map cover 28, out of the housing 24. As illustrated, the slot 30 is approximately .25 inches (6 mm) in width, although the slot may be wider or narrower, depending on the map cover 28 material which is used. It is preferred that the slot 30 be as narrow as possible while still allowing proper functioning of the device, so as to minimize the area through which snow or other foreign matter may enter the outer housing 24.

10 The housing 24 is, as illustrated in FIG. 1, removably attached to the outside of the ski pole 20. Two screw clamps 32 secure the housing 24 to the pole 20. The screw clamps 32 are bands 34 which form loops and interlock onto themselves, and may be tightened through the use of screws which engage small ratchets in the bands. It is preferred that the clamps 32 be low in profile so as not to protrude from the housing 24 or pole 20 and cause injury. To facilitate such, a narrow notch 40 is formed into the outside of the housing 24 to allow each band 34 to rest therein. Further, the screw which is used to tighten and loosen the clamps 32 are placed inside a smooth cover (not shown).

15 The clamps 32 allow the skier to attach or detach the map holder 22 from the ski pole 20. In the illustrated embodiment, this may be accomplished with only a screw driver. Alternatively, the housing 24 may be attached to the ski pole 20 by welding, a pin and slot arrangement, screws or other means known to those skilled in the art.

20 As shown in FIGS. 2 and 3, caps 42 enclose the ends of the outer housing 24. The caps 42, as illustrated, are made of the same type of plastic as the housing 24 so as to be corrosion resistant and rigid. The caps 42 have an insertion section 43 which is formed to be securely inserted into an end of the housing 24, and an outer section 45 which protrudes

therefrom. The insertion section 43 is thus of a slightly smaller diameter than the inside diameter of the housing 24, and has a very short length. The outer section 45 may be of any shape, such as cylindrical or oval; however, it is preferred that outer section have a shape which conforms to the ski pole 20. Therefore, the caps 42, as shown, have an outer section 45 which is conical and has an arcuate cut-away. This cap 42 design eliminates sharp housing 24 and cap 42 edges to protect the skier. While it is possible to have the caps 42 primarily flush with the end surfaces of the housing 24, this is not desirable, as this leaves sharp exposed drop-offs on the ends of the housing 24.

The inner roller 26 is positioned within the outer housing 24. As seen in FIG. 3, the inner roller 26 is a cylindrical tube having a thin slot 46 extending longitudinally therethrough. The roller 26, as illustrated, is about 11.5 inches (29 cm) long. The roller 26 is long enough to hold the map cover 28 and map 82, and yet still fit within the outer housing 24. The inner roller 26 may be of other sizes, however, depending on the size of the map cover 28 and size of the housing 24 with which it is to be used. The outer diameter of the roller 26 is about .5 inches (10.5 mm). The small outer diameter of the roller 26 allows maximum rolling space between the roller 26 and the inside of the housing 24, and yet provides a rolling surface which is large enough to provide smooth rolling of materials thereon. The roller 26 may be made of any material which is strong and corrosion resistant, such as aluminum or plastic.

A plug 48 is placed in each end of the roller 26. The plugs 48 are plastic tabs which enclose the ends of the roller 26. Each plug 48 has a small bore 50 therethrough to allow the introduction of first and second shafts 52, 54.

The first shaft 52 is cylindrical, being about 2 inches (5 cm) long and about .15 inches (3.7 mm) in diameter. The first shaft 52 extends from inside the roller 26, through the bore 50 in the plug 48, to a point about .5 inches (1 cm) outside of the roller 26. The second shaft 54 at the other

end of the roller 26 is primarily cylindrical, having a length of about 7 inches (17.5 cm), and a diameter of about .15 inches (3.7 mm). The second shaft 54, however, has a flat engaging end 56 and a slotted end 58. The second shaft 54 extends from the slotted end 58 located inside the roller 26, through the bore 50 in the plug 48, and outside of the roller 26 to the engaging end 56. The engaging end 56 is rectangular in shape and extends along the shaft 54 just at the very end. It is possible, of course, to mount the roller 26 upon only one shaft extending through both plugs 48. However, to reduce the weight of the map holder 22, as well as keep material costs low, two short shafts 52, 54 are desired.

A spring 60 is mounted on the second shaft 54. The spring 60 is connected at one of its ends to the shaft 54, and at its other end to the plug 48. As illustrated, the spring 60 is attached to the shaft 54 by pinching one free end of the spring 60 in the slot 58 in the shaft 54. The other free end of the spring 60 engages a small detent 62 in the plug 48 inside the roller 26. The spring 60, as shown, is about 5 inches (12.5 cm) long and provides a force sufficient to retract the map 82 and map cover 28 into the roller 26. While the spring 60 and roller 26 described above form a spring roller mechanism which works well in retracting the map 82, there are other means by which the roller 26 could be resiliently rotated. For example, the spring 60 could be attached to the outside end of the roller 26. The spring 60 could also be connected so as to stretch instead of wind, like through use of a resilient material positioned so as to be coiled about the roller 26 as it turns, as is apparent to one skilled in the art.

Two discs 64 are mounted inside the housing 24 very near the ends of the housing. The discs 64 are thin circular members which are secured to the inside of the housing 24. Each disc 64 has a mounting hole 66 a,b at its center.

The end of the first shaft 52 extending from the roller 26 engages one mounting hole 66a. This mounting hole 66a is circular, so as to allow the cylindrical first shaft 52 to

free-wheel therein. The other mounting hole 66b is rectangular so that the engaging end 56 of the second shaft 54, when inserted into the hole 66b, is prevented from rotating.

5 Alternatively, the mounting holes 66a,b may be formed into the inside of the insertion end 43 of the end caps 42. In this case, no discs 64 are necessary. The holes 66a,b are, in this alternate instance, located in the center of the insertion section 43 of the caps 42. This feature is
10 advantageous as it allows access to, and removal of, the internal roller 26 mechanism merely by removing one of the caps 42. However, this embodiment has the disadvantage of having one less seal (the disc 64) to protect the inside of the housing 24 from foreign element.

15 As will now be apparent from the above description, the mounting of the roller 26 inside the housing 24 allows the roller to rotate as impeded only by the spring 60. The spring 60, as positioned, biases the roller 26 to a non-rotated position.

20 In conjunction with FIG. 7 and as illustrated more clearly in FIGS. 8 and 9, there is illustrated a preferred inner roller mechanism which includes a lock 91. The lock 91 comprises a slider 92 connected to an engaging ratchet 93, and a gear 49 connected to the inner roller 26.

25 The gear 49 is, as shown, circular and formed as part of one of the plugs 48 located in one of the ends of the inner roller 26. The gear 49 has a number of engaging teeth 47 located about its outer surface.

30 The slider 92 is a small square button shaped for easy manipulation by a finger or thumb of a user. The slider 92 is located on the outside surface of the housing 24 (this is illustrated in FIG. 7 in conjunction with the lock 91 on the second embodiment, described below). A tab (not shown) protrudes from the side of the slider 92 facing the housing
35 24.

 The ratchet 93 is a primarily thin rectangular block having teeth 94 on one face. The ratchet 93 is located on the

inside of the outer housing 24.

A short longitudinal slot 95 is formed in the outer housing 24. A screw (not shown) is placed in the slider 92, and passes through the slot 95 and engages the ratchet 93 so as to fix the slider 92 and ratchet 93 to one another. The slot 95 is long enough to allow the slider 92 and ratchet 93 to travel a short distance which, as described below, locks and unlocks the roller 26.

A flat ledge 97 is formed into the housing 24 surrounding the slot 95. In this fashion, the slider 92 and ratchet 93 may more easily travel in the slot 95. Two indentations (not shown) are located in the ledge 97 to accept the tabs in the slider 92 when the slider is at various locations along the slot 95.

The slider 92 and ratchet 93 are positioned on a point on the housing 24 such that the ratchet 93 may be moved into a position where it engages the gear 49 on the plug 48. The indentations on the ledge 97 are positioned such that the slider 92 is securely stationed by engagement with the tab in two positions: one corresponding to when the lock is unlocked, and one corresponding to a locked position.

It is noted that if the inner roller 26 is mounted directly to the end caps 42 and not to discs 64 located inside the housing 24, then the slider 92 and ledge 97 will be positioned on one of the caps 42 instead of along the housing 22. The gear 49 and ratchet 93 are positioned as described above, as would be apparent to one skilled in the art.

The operation of the lock 91 will now be described in conjunction with FIGS. 8 and 9. As illustrated in FIG. 9, the slider 92 is normally in a position corresponding to that where the ratchet 93 is not engaging the gear 49. This position is maintained by the tab and indentation arrangement. When the slider 92 is in this position, the inner roller 26 may rotate freely, allowing the map 82 and map cover 28 to be extended and retracted.

When the map 82 is to be removed or replaced, or it is otherwise desired to fix the map 82 for viewing, the inner

roller 26 is locked into position. This is accomplished by moving the slider 92 along the slot 95 until the ratchet 96 engages gear 49. When the slider 92 moves into a position where the tab engages the second indentation in ledge 97, the ratchet 93 and gear 49 securely engage one another. Until the slider 92 is pushed out of this position, the inner roller 26 is prevented from rotating. This is the locked position best illustrated by FIG. 8.

Referring now to FIGS. 4, 4a and 5, the map cover 28 comprises two sheets 70 a,b of transparent, water-proof, durable, flexible material. As illustrated, the sheets 70a,b are made from polyvinylchloride. This material is chosen because it has the above desired qualities and remains flexible at temperatures as low as -40 degrees F. Other materials, such as polyethylene or polypropylene may be used, as they are durable in cold weather; however, these materials are somewhat less flexible and so do not roll up as easily.

The sheets 70 a,b are each about 16 inches (40 cm) long and 9 inches (23 cm) tall, and about 0.1 inches (.23 mm) in thickness. The exact dimensions of the sheets 70 a,b are primarily a function of the size of the map 82 which is to be contained therein. Map cover 28 lengths over 24 inches (60 cm) and heights of 20 inches (50 cm) are contemplated. The above dimensions are preferable as the cover 28 is large enough to house most ski trail maps 82, and yet is not so large that the overall size of the map holder 22 becomes cumbersome.

The sheets 70a,b are bound together at attached ends 72 a,b. This is accomplished, as illustrated, by heat sealing the attached ends 72 a,b of the sheets 70 a,b. The heat sealing creates a tab 74 where the ends 72 a,b meet. It is, of course, possible to form the map cover 28 from one sheet where this single sheet is folded so as to form two sheets. The point at which a single sheet is folded may then be bonded or formed so as to create the tab 74.

Each of the sheets 70a,b has a free end 76a,b which is located outside of the housing 24. One sheet 70b has a free

end 76b which is slightly tapered on its top and bottom so that its height is somewhat less at this free end than throughout the rest of the length of the sheet (FIG. 4a)

5 The other sheet 70a has a free end 76a which has a flap 88 and a clam shell cover 80 attached thereto (FIG. 4a). The flap 88 is a pocket formed onto the free end 76a of the sheet 70a. The flap 88 is, as illustrated, 2 to 3 inches (5 to 8 cm) in width, and is as tall as the sheet 70a. The flap 88 is formed by folding over the free end 76a of the sheet 70a and then heat sealing or gluing the top and bottom of the folded area together. The fold area is then bonded to the clam shell cover 80, leaving the edge of the flap 88 which faces towards the housing 24 open. It is possible, of course, to form the flap 88 from a separate piece of material, as would be apparent to one skilled in the art.

10 The flap 88 is sized to permit the insertion of the tapered free end 76b of the other sheet 70b therein. In this manner, the free end 76a of sheet 70a securely engages the free end 76b of sheet 70b. At the same time, the flap 88 arrangement allows the sheets 70a,b to crawl with respect to one another, as will be more fully described below.

15 The cover 80 attached to sheet 70a is a thick, primarily C-shaped or clam shell shaped member having a flange 86 and handle 90. The cover 80 is preferably at least as long as the longitudinal slot 30. The flange 86 is located near the center of the cover 80 on the side of the cover 80 which faces the housing 24. The flange extends the full length of the cover 80. The flange 86, as illustrated in FIG. 5, is sized to fit within the slot 30.

20 The handle 90 is a flexible tab-like member which extends from the midpoint of the cover 80. The handle 90 is preferably made from a durable flexible material easily grabbed onto, such as leather or a mesh nylon fabric. The handle 90 is sized to permit a skier to easily grab onto it so as to pull the cover 80 from the housing 24.

25 The map cover 28 is attached to the roller 26 inside of the housing 24. The tab 74 at the attached ends 72 a,b of the

5 sheets 70a,b of the cover is positioned inside the roller 26, with the sheets 70a,b extending therefrom. As can be seen, the slot 46 in the roller 26 is sized (.6-.7 mm width) so that the tab 74 can not pull therethrough. The map cover 28 could be attached to the roller 26 in any of a number of other means known to those skilled in the art, such as by gluing or riveting.

10 The sheets 70 a,b of the map cover 28 extend from the roller 26 out of the slot 30 in the outer housing 24. The sheets 70a,b are prevented from recoiling through the slot 30 to the inside of the housing 24 by the cover 80 on sheet 70b. In this fashion, the free ends 76 a,b of the sheets 70a,b are always freely accessible.

15 As illustrated in FIGS. 1 and 4, a map 82 may be positioned inside the map cover 28 between the two sheets 70a,b thereof. One or more strips of adhesive 84 are located on the sides of the sheets 70a,b which face one another. As shown, the strip of adhesive 84 is located near the attached ends 72a,b of the sheets 70a,b, extending the full height of the sheets 70a,b and being about 3 inches (7.5 cm) in width. This adhesive 84 is of a type which allows repeated engagement and disengagement of material without serious degradation of the adhesive. The map 82 which is placed in the map cover 28 is stationed securely therein by placing one edge of the map 20 82 in the area of the adhesive 84, and then pressing the sheets 70a,b together.

25 The map 82 is securely stationed in the map cover 28 so as to permit easy visualization thereof. Further, such placement protects the map from foreign material, especially snow. The map cover 28 is also openable so as to allow the user to interchange maps 82. While the above map cover 28 accomplishes these ends, it is possible to make the entire map cover 28 in the form of a pocket, or alternatively, have the map cover made of two sheets which are releasably securable 30 along all edges.

35 Alternatively the sheets might be connected by engaging bars (not shown). In this form, one sheet may have a column

positioned at its free end. The column may be a shaft which is attached to the free end of the sheet by sliding it inside a loop of material at the free end of the sheet so as to capture the column therein. A recess might be positioned inside of the flange 86 of the cover 80, the recess 88 being large enough to accommodate the column 78 therein. In this fashion, the sheets might be attached to one another by inserting the column on the first sheet into the recess in the second sheet, whereby the sheets would be locked to one another at their free ends.

When the map cover 28 comprises two sheets 70a,b of material, however, these sheets must be allowed to move with respect to one another, or "crawl", as the map cover 28 is rolled onto the roller 26. Otherwise, the sheets will buckle and wrinkle. It is preferred, therefore, that the sheets 70a,b not be directly attached to one another except very near their attached ends 72 a,b located near the roller 26. These functions are not easily accomplished with a map cover 28 in the form of a pocket or two sheets releasably secured along all edges. These functions are accomplished by the map cover 28 discussed above, as the tapered free end 76b of sheet 70b is allowed to move back and forth inside flap 88 on sheet 70a, and yet not come loose from the flap 88.

Lastly, the map cover 28 must securely station the map 82 therein. In the embodiment described above, this is accomplished through the use of one or more adhesive strips 84 located near the attached ends 76a,b of the sheets 70a,b. The two sheet 70a,b map cover 28 arrangement with adhesive 84 allows the map 82 to be secured, be easily removed, and allows the sheets 70a,b to crawl as they are rolled and unrolled. Lastly, the arrangement described above where in the map is securely attached inside the cover 28 with the adhesive 84 at one end, and by the engagement of the sheets 70a,b at their free ends 76a,b protects the map 82 from foreign elements.

If it is necessary to further protect the map 82 from foreign elements, the map cover 28 may be made from material which is somewhat statically attracted to itself. For

example, the sheets 70a,b might be made of a plastic which is attracted to itself, so that the sheets stick to one another. If the attraction is not too great, the sheets 70a,b will be forced to crawl so as not to buckle or wrinkle, and yet remain in contact with one another so as to provide a closed map environment.

It is preferred that the ski area map 82 will be placed in the map holder 28 described above. However, it is possible to laminate each map 82 with plastic or other material, and then install the map 82 directly to the inner roller 26 in the holder 22. In this form, the map 82 and its transparent protective covering is a single sheet and is easily rolled or unrolled from the roller 26 when connected thereto. Alternatively, the map 82 could be printed on a clear sheet of water-resistant material, such as plastic, which could be attached to a roller or tube for retraction into a housed position and extension into a viewing position.

The total weight of the map holder 22, as comprised of the above described components, should weigh less than about 10 oz. (285 g); however, it is preferred that the holder 22 weigh no more than about 7 oz. (200 g). As a ski pole typically weighs about 24 oz. (1 Kg), it is therefore preferred that the holder 22 weigh less than about one-third of the weight of the pole 20. In this manner, the added weight of the holder 22 is not noticeably significant. Further, because the added weight is located near the top of the ski pole 20, the added weight is less noticeable. This is because the top of pole 20 is pivoted at the hand of the user. This point is far from the free end of the pole which is swung about freely by the user.

The operation of the map holder 22 will now be described. A user may either buy a ski pole 20 with the holder 22 already attached, or the user may attach the map holder 22 to a ski pole 20 with the clamps 32 him or herself. To self-mount the holder 22, the holder 22 is positioned on the pole 20 at the point most convenient to the user, and the clamp 32 is tightened around the pole 20 and holder 22 with the screws 36.

The pre-folded ski area trail map 82 is unfolded either partially or completely so as to expose the map, and is then positioned inside of the map cover 28. The positioning of the map 82 is accomplished by first extending the map cover 28 from the housing 24. The map cover 28 is pulled from the housing 24 by grabbing the handle 90 on the cover 80 with one or more fingers. The map cover 28 is then fully extended from inside the housing 24.

Once the roller 26 is fully extended, the lock 91 is engaged, as fully described above. The sheets 70a,b of the cover 28 are separated by sliding the tapered free end 76b of sheet 70b out from inside the flap 88 on sheet 70a. The map 82 is inserted between the sheets 70a,b with one edge of the map located along the adhesive area 84. The sheets 70a,b are then pressed together to secure the map 82 securely in the cover 28. The free end 76b of sheet 70b is then pressed into the flap 88 on sheet 70a so that the sheets 70a,b engage one another.

The lock 91 is then disengaged as described above, and the cover 28 is allowed to retract into the housing 24 automatically by the spring biased roller 26. The map 82 may then be viewed by the user at any time by extending the map cover 28 from the housing 24.

If it is desired, the lock 91 may be re-engaged when the map 82 is extended for viewing. This allows the user to release his or her grip from handle 90 while viewing the map 82.

An alternate embodiment of the map holder 122 is shown in FIGS. 6 and 7. In this embodiment, the map holder 122 comprises the same component parts as the above described embodiment, except that the housing is the ski pole 120 and not a separate outer housing 24 as above.

In this embodiment, the ski pole 120 acts as the housing. Because ski poles 120 typically have an inner diameter of .5-1 inch (12-25 mm) near their handles, the pole 120 in which the map 182 is to be housed must be enlarged slightly so that it has an inner diameter large enough to accommodate the roller

126 with the map cover 128 and map 182 rolled thereon. A longitudinal slot 130 is machined out of the pole 120, the slot 130 having dimensions similar to those described above.

Discs 164 are fitted in the pole 120. The discs 164 should be fitted in the pole 120 in a manner so as to prevent the penetration of water or other material past them into the remaining interior portion of the pole 120. This may be accomplished by using a caulking or sealant between the discs 164 and pole 120, or by melting the discs 164 to the pole 120 sides. The discs 164 should have the same type of mounting holes 166a,b as those described above.

The discs 164 are mounted in the pole 120 a distance apart so that a spring biased inner roller 126 with shafts 152, 154 and plugs 148 like those above, may be inserted.

It is also preferred that a lock 91, like that described above, be incorporated. The lock 91 is positioned at the end of the inner roller 126, the lock 91 being the same as that illustrated in FIGS. 8 and 9.

A map cover 128 is once again attached on one end 172 to the roller 126, and extends to a free end 176 out of the slot 130 in the pole 120. The free ends 176 of the map cover 128 have the same flap 188 engagement as described before, and a clam shell cover 180 with a handle 190 are again used to seal the slot 130 and provide a gripping surface.

The entire map holder 122 should once again weigh less than 10 oz. (285 g), however, it is again preferable that it not weigh more than about 7 oz. (200 g) so that the added weight is not substantially noticeable. It is noted that if the map 84 is printed directly upon a single water-resistant, durable material, as described above, the weight of the holder 122 may be further reduced.

It is possible that when using larger map covers 128 with a longer slot 130, the pole 120 may need reinforcing ribs or other structures so that the structural integrity is not compromised. It is believed, however, that with smaller slot 130 widths, as contemplated here, the pole 120 integrity will not be compromised.

It will be understood that the above described arrangements of apparatus and the methods therefrom are merely illustrative of applications of the principles of this invention and many other embodiments and modifications may be made without departing from the spirit and scope of the invention as defined in the claims.

WHAT IS CLAIMED IS:

1. A ski area trail map holder comprising:
a ski pole;
a roller attached to said ski pole; and
5 a map retractably and extendably mounted on said roller.
2. The trail map holder of Claim 1, wherein said roller is mounted inside a housing attached to the outside of said ski pole.
- 10 3. The trail map holder of Claim 1, wherein said map is secured inside a map cover which is attached at one end to said roller.
4. The trail map holder of Claim 1, wherein said roller is spring biased to urge the map into a retracted position.
- 15 5. The trail map holder of Claim 1, wherein said roller is mounted inside said ski pole and along the longitudinal axis thereof, and said map is extendable through a longitudinal slot in said pole.
6. The trail map holder of Claim 1, wherein the entire holder weighs less than about 7 ounces.
- 20 7. The trail map holder of Claim 1, additionally comprising a lock for securing said roller in a stationary position.
8. A ski area trail map holder for use with a ski pole and for containing a ski area trail map, said holder (i) allowing a skier to extend an unfolded ski area trail map into a viewing position, as well as retract the unfolded map into a stored position without the need of the skier to unfold said map or store his or her gloves or poles while viewing the map,
25 (ii) protecting said map from the elements, and (iii) securely holding said map during use while permitting the skier to easily remove and replace a given ski area trail map, comprising:
30 a substantially tubular housing having a longitudinal axis and two ends, said housing adapted for use in conjunction with said ski pole, and said housing having a longitudinal slot therein;

5 a roller rotatably mounted inside of said housing and along the longitudinal axis thereof, said roller having a surface upon which a map may be rolled, and having a spring attached thereto so that said roller is resiliently urged so that a map connected thereto is biased into a retracted position;

10 a map cover, said map cover comprising two sheets of transparent material between which sheets a ski area trail map may be stationed for viewing and storage, said map cover connected at one end to said roller and having a second end for extension through said longitudinal slot in said housing;

15 a ski area trail map, said map being unfolded and stationed inside of said map cover, said map being releasably secured to the inside of said map cover by adhesive located on the inside of said map cover sheets near their connection with said roller, and by the close proximity of said map cover sheets at their ends which are designed for extension through said longitudinal slot; and

20 a handle connected to said map cover, said handle preventing said roller from retracting said map cover and a map located therein completely onto said roller, and to allow said map to be grasped for extension into a viewing position.

25 9. A ski area trail map holder for use with a ski pole and for containing a ski area trail map, said holder (i) allowing a skier to extend an unfolded ski area trail map into a viewing position, as well as retract the unfolded map into a stored position without the need of the skier to unfold said map or store his or her gloves or poles while viewing the map, (ii) protecting said map from the elements, and (iii) securely holding said map during use while permitting the skier to easily remove and replace a given ski area trail map, comprising:

30 35 a substantially tubular housing having a longitudinal axis and two ends, said housing adapted for

use in conjunction with said ski pole, and said housing having a longitudinal slot therein;

5 a roller rotatably mounted inside of said housing and along the longitudinal axis thereof, said roller having a surface upon which a map may be rolled, and having a spring attached thereto so that said roller is resiliently urged so that a map connected thereto is biased into a retracted position;

10 a map cover, said map cover comprising two sheets of transparent material between which sheets a ski area trail map may be stationed for viewing and storage, said map cover connected at one end to said roller and having a second end for extension through said longitudinal slot in said housing;

15 a ski area trail map, said map being unfolded and stationed inside of said map cover, said map being releasably secured to the inside of said map cover by adhesive located on the inside of said map cover sheets near their connection with said roller, and by the close proximity of said map cover sheets at their ends which are designed for extension through said longitudinal slot; and

20 a handle connected to said map cover, said handle allowing said map to be grasped for extension into a viewing position.

25 10. A ski area trail map holder for use with a ski pole and for containing a ski area trail map, said holder (i) allowing a skier to extend an unfolded ski area trail map into a viewing position, as well as retract the unfolded map into a stored position without the need of the skier to unfold said map or store his or her gloves or poles while viewing the map, (ii) protecting said map from the elements, and (iii) securely holding said map during use while permitting the skier to easily remove and replace a given ski area trail map, 30 comprising:

35 a substantially tubular housing having a longitudinal axis and two ends, said housing adapted for

use in conjunction with said ski pole, and said housing having a longitudinal slot therein;

5 a roller rotatably mounted inside of said housing and along the longitudinal axis thereof, said roller having a surface upon which a map may be rolled, and having a spring attached thereto so that said roller is resiliently urged so that a map connected thereto is biased into a retracted position;

10 a map cover, said map cover comprising two sheets of transparent material between which sheets a ski area trail map may be stationed for viewing and storage, said map cover connected at one end to said roller and having a second end for extension through said longitudinal slot in said housing; and

15 a ski area trail map, said map being unfolded and stationed inside of said map cover, said map being releasably secured to the inside of said map cover by adhesive located on the inside of said map cover sheets near their connection with said roller, and by the close
20 proximity of said map cover sheets at their ends which are designed for extension through said longitudinal slot.

11. A ski area trail map holder for use with a ski pole and for containing a ski area trail map, the holder (i)
25 allowing a skier to extend an unfolded ski area trail map into a viewing position, as well as retract the unfolded map into a stored position without the need of the skier to unfold said map or store his or her gloves or poles while viewing the map, (ii) protecting said map from the elements, and (iii) securely
30 holding said map during use while permitting the skier to easily remove and replace a given ski area trail map, comprising:

a ski pole having a longitudinal slot therein;
35 a roller rotatably mounted inside of said housing and along the longitudinal axis thereof, said roller having a surface upon which a map may be rolled, and having a spring attached thereto so that said roller is

resiliently urged so that a map connected thereto is biased into a retracted position;

5 a map cover, said map cover comprising two sheets of transparent material between which sheets a ski area trail map may be stationed for viewing and storage, said map cover connected at one end to said roller and having a second end for extension through said slot in said housing; and

10 a handle connected to said map cover, said handle preventing said spring roller mechanism from retracting said map cover and a map located therein completely onto said roller, and to allow said map to be grasped for extension into a viewing position.

15 12. A ski area trail map holder for use with a ski pole, and for containing a ski area trail map, said holder including a means for connecting a ski area trail map to said pole to allow extension or retraction of said map, comprising:

20 a spring roller mechanism rotatably attached to said ski pole, said spring roller mechanism including a roller with a surface upon which a map may be rolled, and said spring roller mechanism being resiliently urged so that a map connected thereto is biased into a retracted position.

25 13. The ski area trail map holder of Claim 12, in which the ski area trail map is contained in a map cover, said map cover attached at one end to said roller and having another end for grasping to allow said map cover and map therein to be extended for viewing, said cover adding in the protection of said map from various elements.

30 14. The ski area trail map holder of Claim 12, in which the spring roller mechanism is housed in a tubular housing attached to said ski pole and having a longitudinal slot through which a map may be extended.

35 15. The ski area trail map holder of Claim 12, in which said spring roller mechanism is mounted inside of said ski pole and said ski pole has a longitudinal slot therein through which a map may be extended.

16. A ski area trail map holder for use with a ski pole

comprising:

a tubular housing adapted for attachment to said ski pole, said housing having a longitudinal slot therein;
an inner roller rotatably mounted to said housing.

5 17. The trail map holder of Claim 16, additionally comprising a map and map cover, said map being housed in said map cover, said map cover attached at one end to said roller and extending to a free end located outside of said housing.

10 18. The trail map holder of Claim 16, additionally comprising a map retractably and extendably mounted on said roller.

19. The trail map holder of Claim 16, additionally comprising caps located in each end of said housing.

15 20. The trail map holder of Claim 16, additionally comprising a lock for securing said inner roller.

21. The trail map holder of Claim 16, wherein said holder weighs less than about 7 ounces.

22. A ski area trail map holder comprising:

20 a ski pole having a longitudinal slot therein;
a rotatable roller mechanism, said roller mechanism mounted in said pole; and

a map cover for housing a ski area trail map, one end of said map cover attached to said roller and the other end of said cover located outside of said ski pole.

25 23. The trail map holder of Claim 22, wherein said roller mechanism is spring biased into a retracted position.

24. The trail map holder of Claim 22, wherein said roller is attached at its ends to discs mounted in said pole.

30 25. The trail map holder of Claim 22, additionally comprising a lock for securing said roller mechanism.

26. A ski area trail map holder for use with a ski pole comprising:

a tubular housing for attachment to said ski pole, said housing having a longitudinal slot therein;
35 discs mounted inside said housing;
an inner roller having two ends;
a shaft resiliently connected to one end of said

roller and stationarily connected to one of said discs;
a shaft connected to the other end of said roller
and rotatably connected to the other of said discs.

27. The trail map holder of Claim 26, additionally
5 comprising a map and a map cover, said map being located in
said cover, one end of said map cover being attached to said
roller and the other end of said cover being positioned
outside of said housing.

28. A ski area trail map holder for use with a ski pole
10 comprising:

a tubular housing for attachment to said ski pole,
said housing having a longitudinal slot therein;
one or more means for attaching said housing to said
ski pole;

15 caps for each end of said housing, said caps being
shaped to conform to said pole;

a spring roller mechanism rotatably mounted in said
housing; and

20 a map cover for containing a ski area trail map,
said cover attached to said roller at one end and
extending to a free end located outside said housing.

29. A ski area trail map holder comprising:

a ski pole having an enlarged tubular section and a
longitudinal slot therein; and

25 a spring roller mechanism rotatably mounted in said
enlarged section of said ski pole.

30. The trail map holder of Claim 29, wherein a map
cover for housing a ski area trail map is attached at one end
to said roller and extends to a free end located outside of
30 said pole.

31. A ski area trail map holder for use with a ski pole
comprising:

35 a tubular housing adapted for attachment to a ski
pole, said housing having a longitudinal slot therein;
and

a spring roller mechanism rotatably mounted in said
housing.

32. The trail map holder of Claim 31, wherein said roller is rotatably mounted on a shaft.

33. The trail map holder of Claim 32, wherein one end of said shaft is prevented from rotating with respect to said roller.

34. The trail map holder of Claim 31, additionally comprising a map cover for housing a ski area trail map, said map cover comprising two sheets, said sheets joined at one end at a connection with said roller and having free ends which extend out of said housing through said slot.

35. The ski area trail map holder of Claim 31, additionally comprising a map positioned on said roller mechanism.

36. A ski area trail map holder comprising:
a ski pole; and
a map retractably and extendably mounted to said ski pole.

37. A map cover for use with a roller mechanism of a ski area trail map holder comprising:
two sheets of transparent material, each having free and attached ends, said attached ends connected to said roller and said free ends designed for extension out of said trail map holder.

38. The map cover of Claim 37, additionally comprising adhesive on at least one of said sheets, said adhesive located on the side of said sheet which faces the other sheet and in an area near the attached ends of said sheets.

39. A map cover for use with a map holder having a housing with a longitudinal slot therein and a spring roller mechanism rotatably mounted in said housing, comprising:

two transparent sheets having attached and free ends, each of said sheets connected at said attached end to said roller, and each sheet extending out of said housing through said slot to said free end;

a tapered area located on the free end of one of the sheets;

a flap located on the free end of the other of said sheets, said flap formed such that the tapered free end of the other sheet may be inserted therein; and

5 a cover attached to the free end of the sheet having the flap, said cover extending the length of said slot and having a flange for engaging said slot, whereby said cover prevents the entry of foreign material into said housing through said slot.

10 40. A method for viewing a ski area trail map comprising:

mounting a map holder having a map cover therein to a ski pole;

placing said map inside said map cover; and

15 extending said map from said map holder so as to be viewed.

41. The method of Claim 40, additionally comprising the step of locking said map in its viewing position.

20 42. A method for protecting and accessing a ski area trail map comprising:

confining said map between transparent sheets;

rollably housing said sheets in a tubular housing;

25 extending said map from said housing through a longitudinal slot in said housing.

43. A method for protecting and accessing a ski area trail map comprising:

30 storing a map on a roller connected to a ski pole, so as to allow said map to be extended from the roller to be viewed and retracted on the roller to be stored.

44. A method for protecting a ski area trail map comprising:

retracting a map onto a roller located in a ski area trail map holder.

45. A method for accessing and viewing a ski area trail map comprising:

35 extending said ski area trail map from a roller located in a ski area trail map holder.

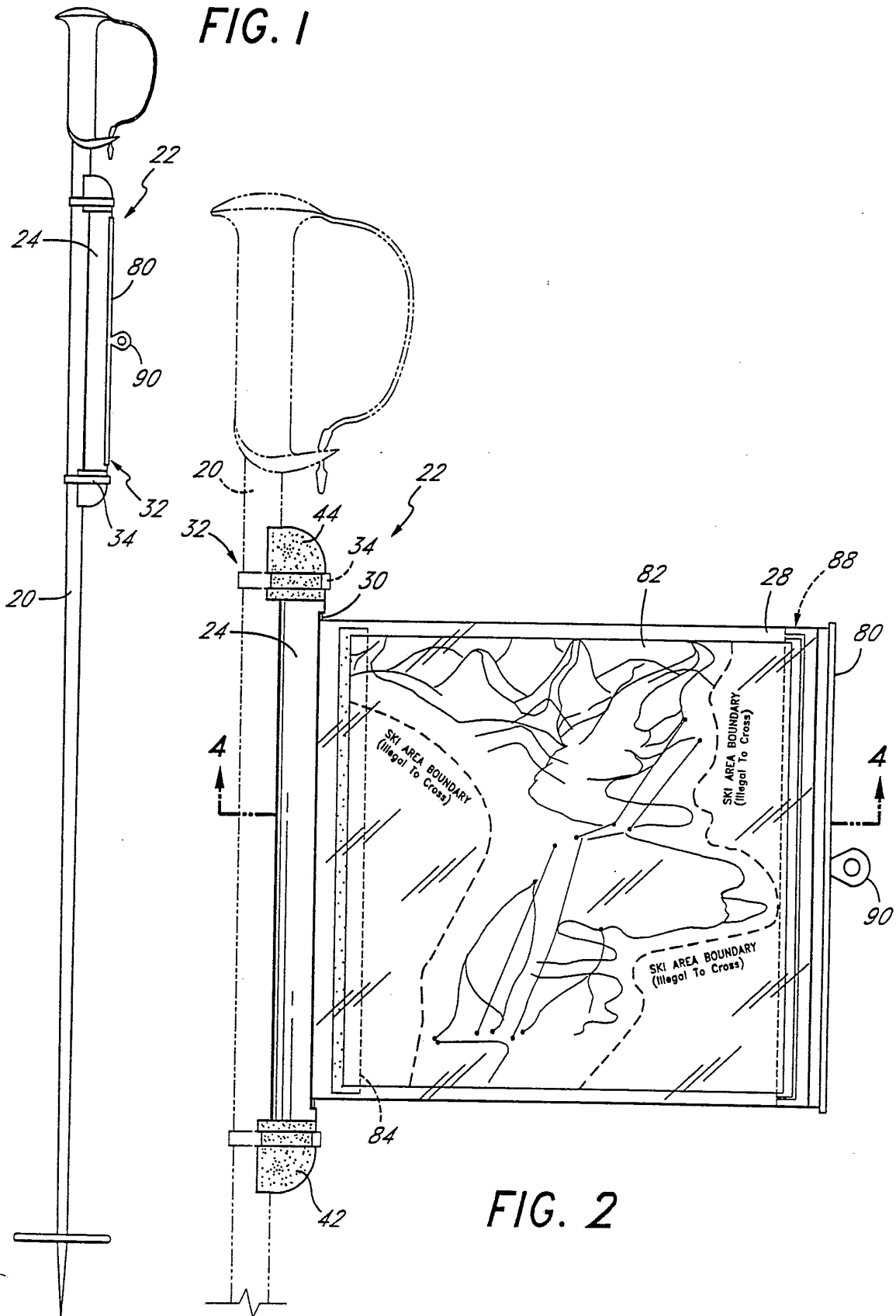

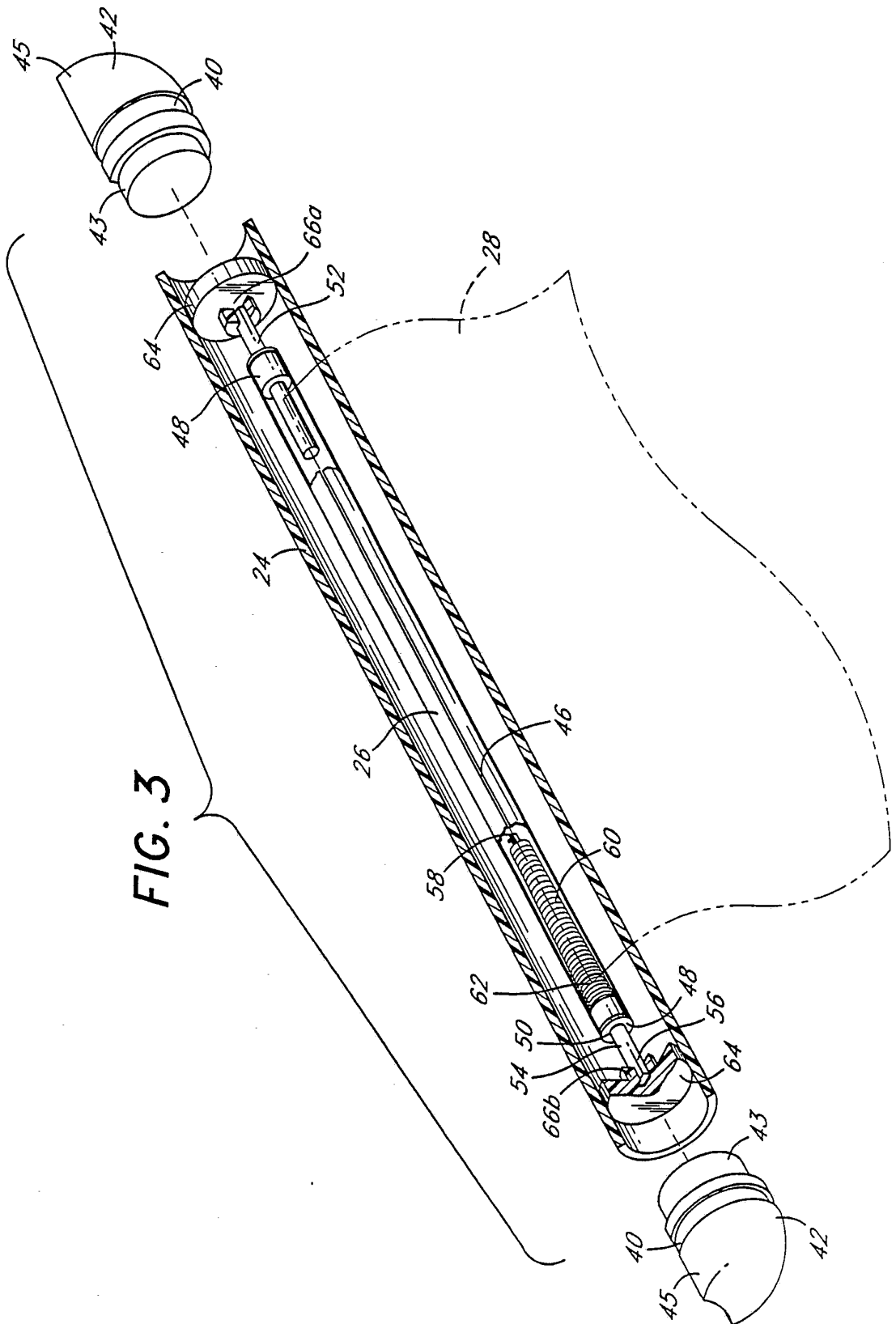
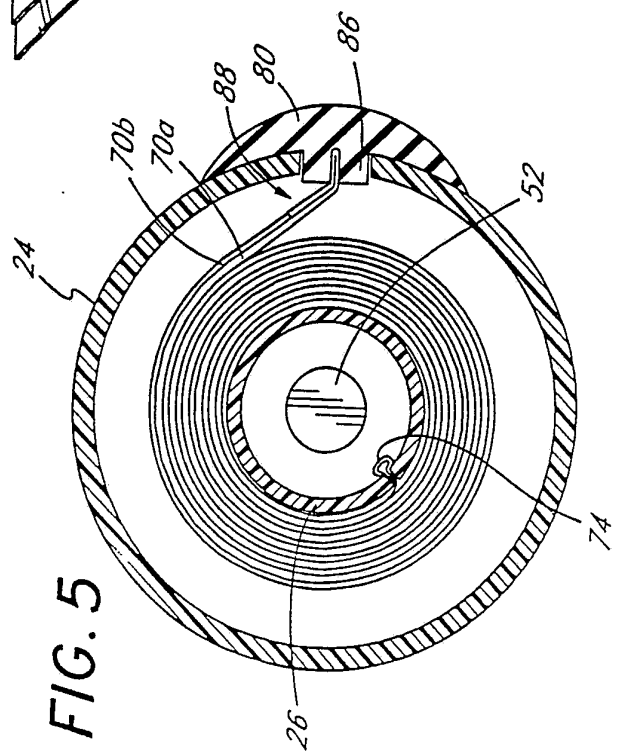
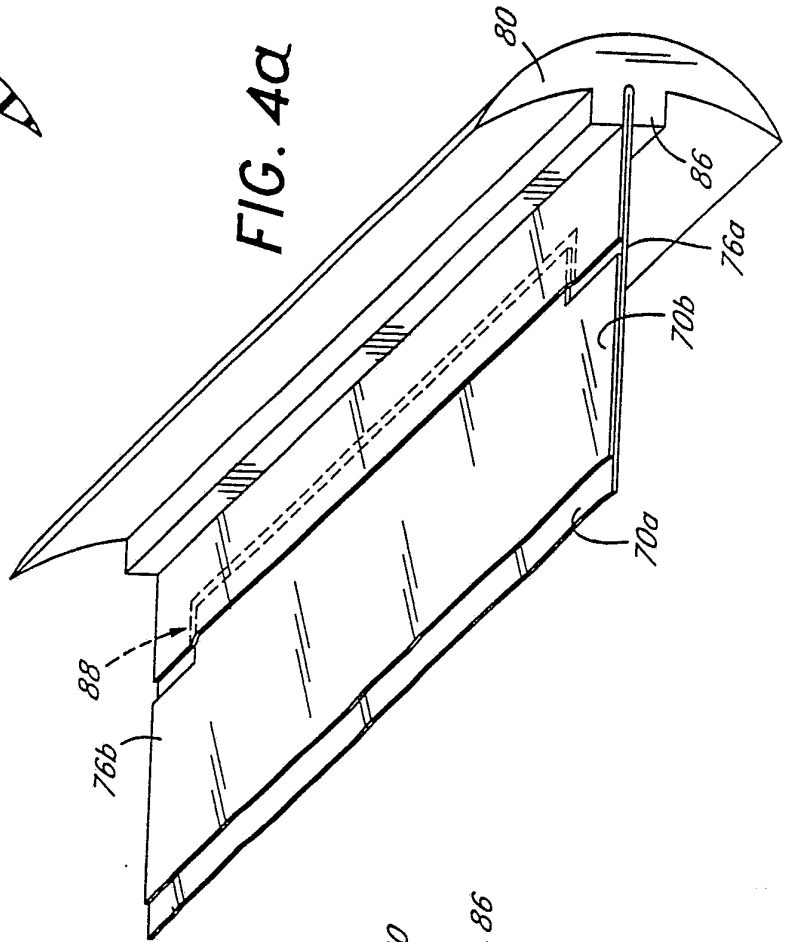
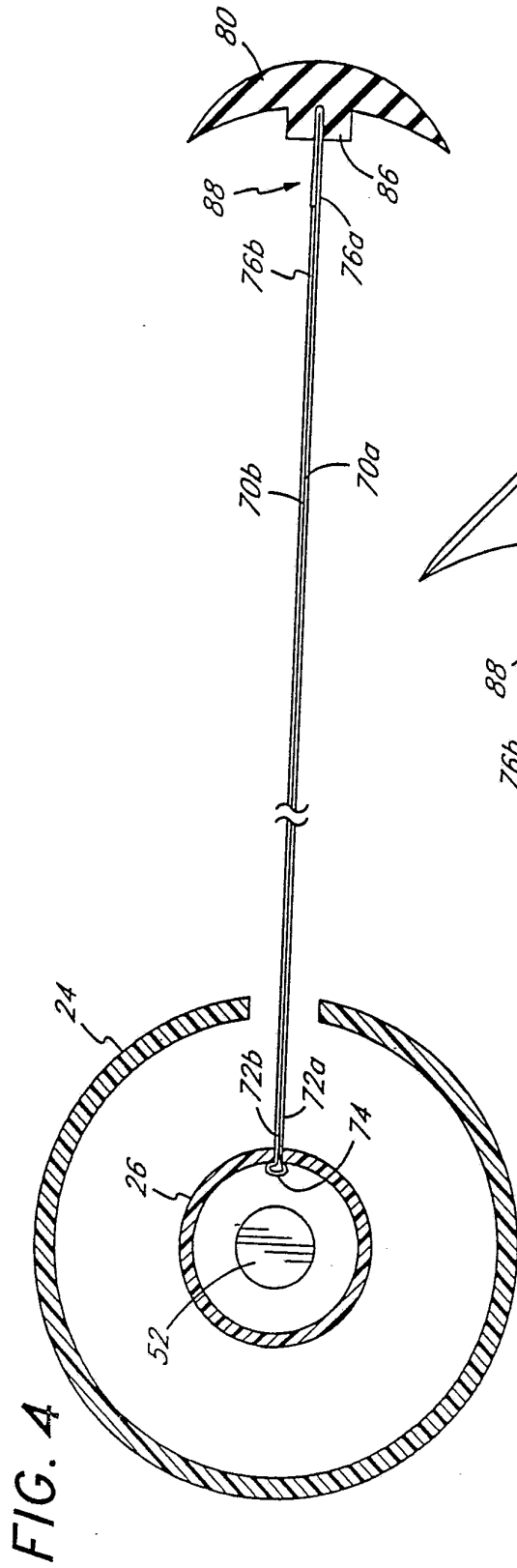
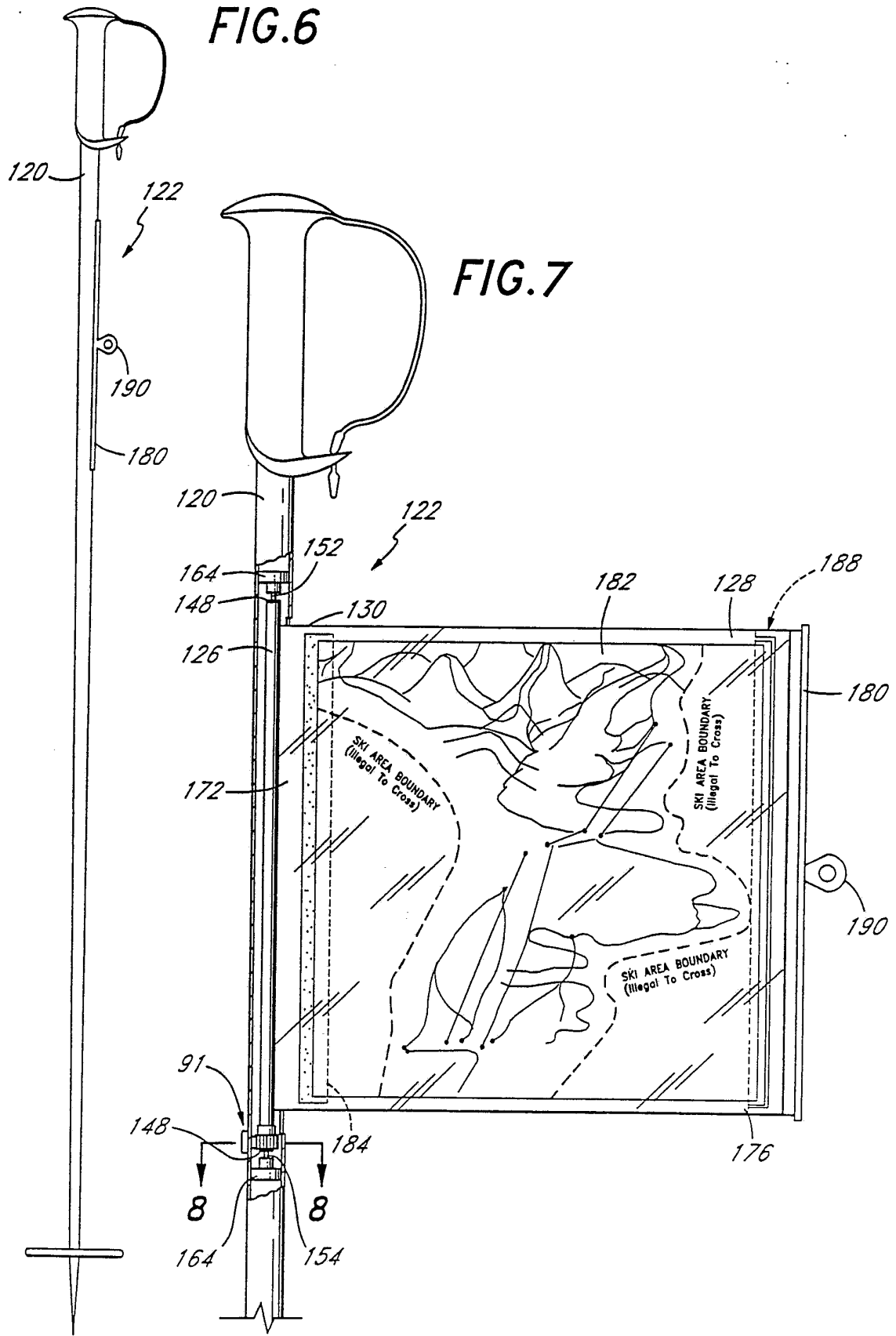

FIG. 3





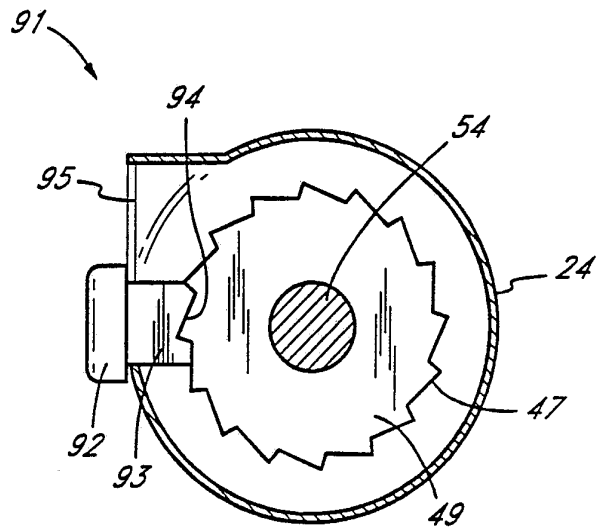

FIG. 8

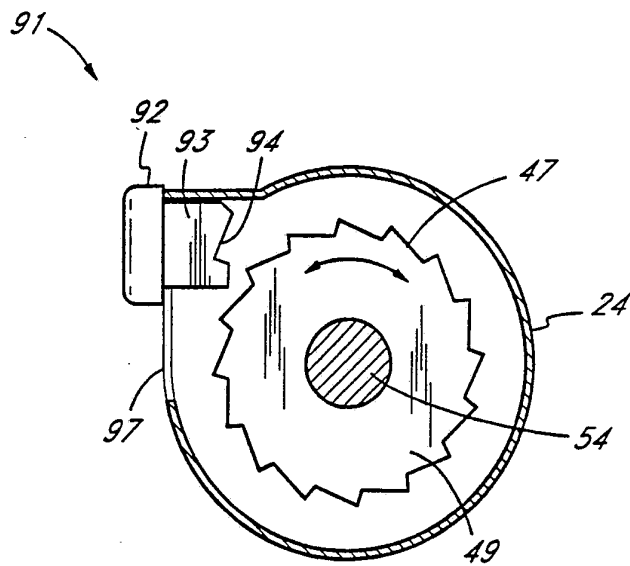

FIG. 9

INTERNATIONAL SEARCH REPORT

International application No.
PCT/US93/04772

A. CLASSIFICATION OF SUBJECT MATTER IPC(5) : G09F 9/00 US CL : 040/517,317,660,334,905,904 According to International Patent Classification (IPC) or to both national classification and IPC		
B. FIELDS SEARCHED Minimum documentation searched (classification system followed by classification symbols) U.S. : 040/517,317,660,334,905,904 Documentation searched other than minimum documentation to the extent that such documents are included in the fields searched Electronic data base consulted during the international search (name of data base and, where practicable, search terms used)		
C. DOCUMENTS CONSIDERED TO BE RELEVANT		
Category*	Citation of document, with indication, where appropriate, of the relevant passages	Relevant to claim No.
X -- Y	US,A 490,722 (PUGH) 31 JANUARY 1893 (SEE FIGURES 1-4, COL. 1, LINES 12-26)	4,8,19,29, 36 ----- 6,7,13,18, 21-35
Y	US,A 495,978 (KLAFF) 25 APRIL 1893 (SEE FIGURES 1-6, COLUMN 1, LINES 15-24)	4, 6 - 8, 13, 18 19,21-35
X -- Y	US,A 498,187 (PUGH) 23 MAY 1893 (SEE FIGURES 1-8, COL. 1, LINES 11-27)	4,8,19,29, 36,43-45 ----- 22,23,25
<input checked="" type="checkbox"/> Further documents are listed in the continuation of Box C. <input type="checkbox"/> See patent family annex.		
* Special categories of cited documents: "A" document defining the general state of the art which is not considered to be part of particular relevance "E" earlier document published on or after the international filing date "L" document which may throw doubts on priority claim(s) or which is cited to establish the publication date of another citation or other special reason (as specified) "O" document referring to an oral disclosure, use, exhibition or other means "P" document published prior to the international filing date but later than the priority date claimed		"T" later document published after the international filing date or priority date and not in conflict with the application but cited to understand the principle or theory underlying the invention "X" document of particular relevance; the claimed invention cannot be considered novel or cannot be considered to involve an inventive step when the document is taken alone "Y" document of particular relevance; the claimed invention cannot be considered to involve an inventive step when the document is combined with one or more other such documents, such combination being obvious to a person skilled in the art "&" document member of the same patent family
Date of the actual completion of the international search 13 SEPTEMBER 1993		Date of mailing of the international search report OCT 1993
Name and mailing address of the ISA/US Commissioner of Patents and Trademarks Box PCT Washington, D.C. 20231 Facsimile No. NOT APPLICABLE		Authorized officer KENNETH DORNER <i>Kenneth J. Dorner</i> Telephone No. (703) 308-2168

INTERNATIONAL SEARCH REPORT

International application No.
PCT/US93/04772

C (Continuation). DOCUMENTS CONSIDERED TO BE RELEVANT		
Category*	Citation of document, with indication, where appropriate, of the relevant passages	Relevant to claim No.
X -- Y	US,A 569,873 (GUY) 4 JANUARY 1898 (SEE FIGURES 1-6, COL. 2, LINES 91-101)	9-11,12,31, 32,43-45 ----- 1-3,6,7,13- 16,18,20, 21,24-35
X -- Y	US,A 764,301 (OSBORN) 05 JULY 1904 (SEE FIGURES 1-5)	4,8,19,29, 36,43-45 ----- 22-24
X -- Y	US,A 772,408 (ELY) 18 OCTOBER 1904 (SEE FIGURES 1-5)	4,8,19,29, 36,43-45 ----- 22-24
X -- Y	US,A 764,997 (FINCH) 12 JULY 1904 (SEE FIGURES 1-2)	4,8,19,29, 36,43-45 ----- 22-24
X -- Y	US,A 1,298,739 (LANGSFORD) 01 APRIL 1919 (SEE FIGURES 1-3)	9,11,12,31, 32,43-45 ----- 1-3,6,7,13- 16,18,20, 21,24-35
Y	US,A 1,364,223 (VENARD) 04 JANUARY 1921 (SEE FIGURES 1-5)	28-24
Y	US,A 2,111,362 (FISHER) 15 MARCH 1938 (SEE FIGURES 1-9)	1-3,6,7,13- 16,18,20, 21,24-35
A	US,A 2,251,579 (RUGG) 05 AUGUST 1941 (SEE FIGURES 1-4)	1-45
A	US,A 991,608 (DAY) 09 MAY 1911 (SEE FIGS 1-4)	1-45
Y	US,A 3,884,351 (JAMES) 20 MAY 1975 (SEE FIGS 1-5)	23,24
Y	GB,A 11,163 (SMITH) 11 MAY 1909 (SEE FIGURES 1-8)	1-45

INTERNATIONAL SEARCH REPORT

International application No.
PCT/US93/04772

C (Continuation). DOCUMENTS CONSIDERED TO BE RELEVANT

Category*	Citation of document, with indication, where appropriate, of the relevant passages	Relevant to claim No.
X	SZ,A 434,986 (HAUSER) 31 OCTOBER 1967 (SEE FIGURES 1-11)	43,45
X	DE,A 2,459,733 (FISCHER) 01 JULY 1976 (SEE FIGURES 1-2)	37,42-45
--		-----
Y		1-3,6,10, 15,24-25, 28,38-40