



(86) Date de dépôt PCT/PCT Filing Date: 2016/11/16  
 (87) Date publication PCT/PCT Publication Date: 2017/05/26  
 (45) Date de délivrance/Issue Date: 2021/11/16  
 (85) Entrée phase nationale/National Entry: 2018/05/11  
 (86) N° demande PCT/PCT Application No.: US 2016/062221  
 (87) N° publication PCT/PCT Publication No.: 2017/087483  
 (30) Priorité/Priority: 2015/11/16 (US62/255,924)

(51) Cl.Int./Int.Cl. *E21B 47/022* (2012.01),  
*E21B 47/09* (2012.01)  
 (72) Inventeurs/Inventors:  
ESTES, ROBERT A., US;  
LEAL, CATALINA, US  
 (73) Propriétaire/Owner:  
BAKER HUGHES, A GE COMPANY, LLC, US  
 (74) Agent: MARKS & CLERK

(54) Titre : PROCÉDES DE FORAGE DE PUIITS PARALLELES MULTIPLES AVEC TELEMETRIE MAGNETIQUE PASSIVE

(54) Title: METHODS FOR DRILLING MULTIPLE PARALLEL WELLS WITH PASSIVE MAGNETIC RANGING

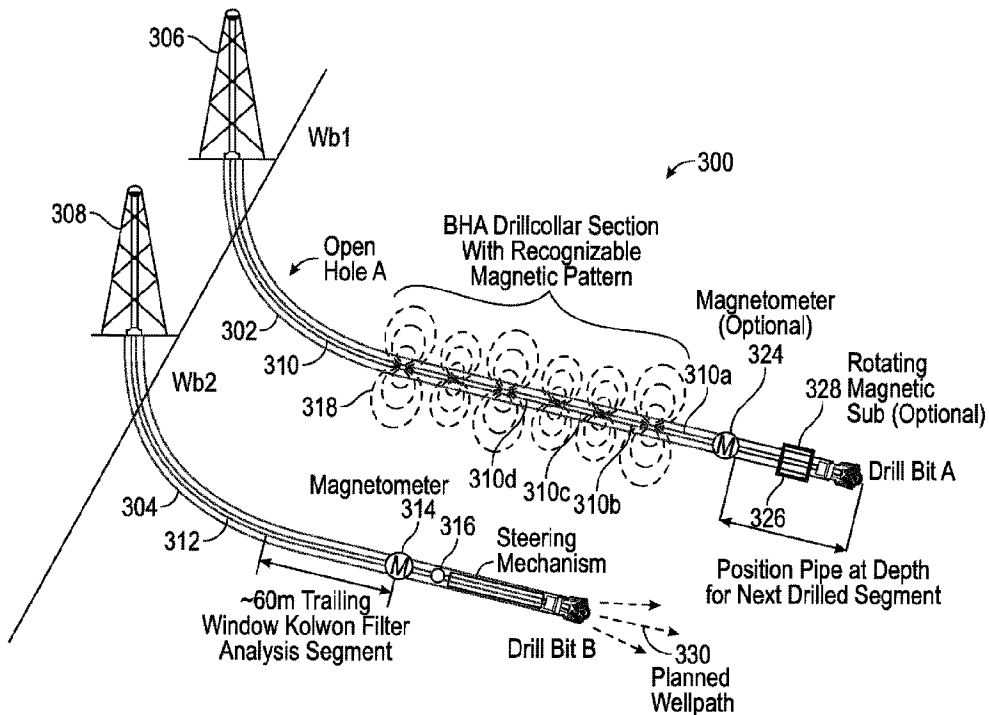

(57) **Abrégé/Abstract:**

A system and method for drilling a second well with respect to a first well is disclosed. A first drill string having a known magnetic signature is disposed at a first depth in the first well. A second drill string is used to drill the second well. The second drill string includes a magnetometer that obtains a magnetic measurement of the first drill string during drilling of the second well. A processor uses the obtained magnetic measurement and the magnetic signature of the first drill string to steer the second drill string to drill the second well.

(12) INTERNATIONAL APPLICATION PUBLISHED UNDER THE PATENT COOPERATION TREATY (PCT)

(19) World Intellectual Property Organization  
International Bureau

(43) International Publication Date  
26 May 2017 (26.05.2017)



(10) International Publication Number  
**WO 2017/087483 A1**

- (51) International Patent Classification:  
*E21B 47/022* (2006.01) *E21B 47/09* (2006.01)
- (21) International Application Number:  
PCT/US2016/062221
- (22) International Filing Date:  
16 November 2016 (16.11.2016)
- (25) Filing Language: English
- (26) Publication Language: English
- (30) Priority Data:  
62/255,924 16 November 2015 (16.11.2015) US
- (71) Applicant: **BAKER HUGHES INCORPORATED**  
[US/US]; 17021 Aldine Westfield, Houston, Texas 77073 (US).
- (72) Inventors: **ESTES, Robert A.**; 17021 Aldine Westfield, Houston, Texas 77073 (US). **LEAL, Catalina**; 17021 Aldine Westfield, Houston, Texas 77073 (US).
- (81) Designated States (*unless otherwise indicated, for every kind of national protection available*): AE, AG, AL, AM, AO, AT, AU, AZ, BA, BB, BG, BH, BN, BR, BW, BY, BZ, CA, CH, CL, CN, CO, CR, CU, CZ, DE, DJ, DK, DM, DO, DZ, EC, EE, EG, ES, FI, GB, GD, GE, GH, GM, GT, HN, HR, HU, ID, IL, IN, IR, IS, JP, KE, KG, KN, KP, KR,

KW, KZ, LA, LC, LK, LR, LS, LU, LY, MA, MD, ME, MG, MK, MN, MW, MX, MY, MZ, NA, NG, NI, NO, NZ, OM, PA, PE, PG, PH, PL, PT, QA, RO, RS, RU, RW, SA, SC, SD, SE, SG, SK, SL, SM, ST, SV, SY, TH, TJ, TM, TN, TR, TT, TZ, UA, UG, US, UZ, VC, VN, ZA, ZM, ZW.

(84) Designated States (*unless otherwise indicated, for every kind of regional protection available*): ARIPO (BW, GH, GM, KE, LR, LS, MW, MZ, NA, RW, SD, SL, ST, SZ, TZ, UG, ZM, ZW), Eurasian (AM, AZ, BY, KG, KZ, RU, TJ, TM), European (AL, AT, BE, BG, CH, CY, CZ, DE, DK, EE, ES, FI, FR, GB, GR, HR, HU, IE, IS, IT, LT, LU, LV, MC, MK, MT, NL, NO, PL, PT, RO, RS, SE, SI, SK, SM, TR), OAPI (BF, BJ, CF, CG, CI, CM, GA, GN, GQ, GW, KM, ML, MR, NE, SN, TD, TG).

**Declarations under Rule 4.17:**

- as to applicant's entitlement to apply for and be granted a patent (Rule 4.17(ii))
- as to the applicant's entitlement to claim the priority of the earlier application (Rule 4.17(iii))

**Published:**

- with international search report (Art. 21(3))

(54) Title: METHODS FOR DRILLING MULTIPLE PARALLEL WELLS WITH PASSIVE MAGNETIC RANGING

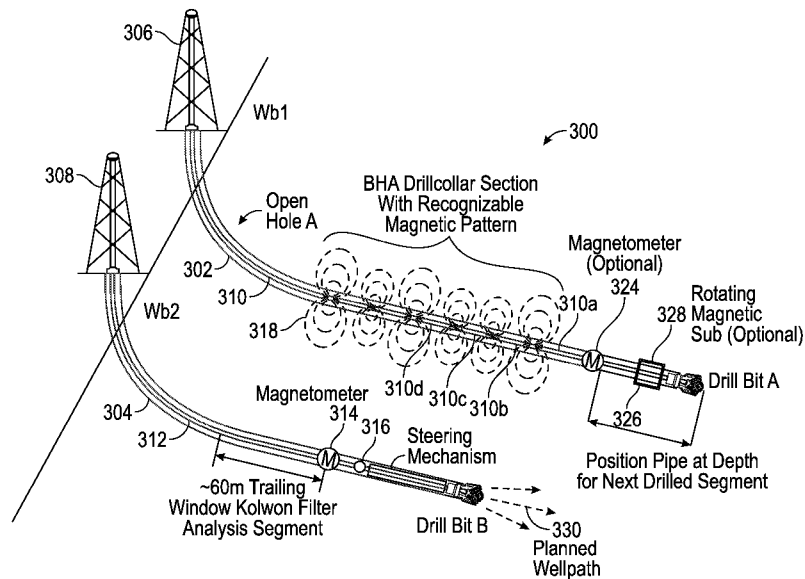

FIG. 3

(57) Abstract: A system and method for drilling a second well with respect to a first well is disclosed. A first drill string having a known magnetic signature is disposed at a first depth in the first well. A second drill string is used to drill the second well. The second drill string includes a magnetometer that obtains a magnetic measurement of the first drill string during drilling of the second well. A processor uses the obtained magnetic measurement and the magnetic signature of the first drill string to steer the second drill string to drill the second well.

WO 2017/087483 A1

## **METHODS FOR DRILLING MULTIPLE PARALLEL WELLS WITH PASSIVE MAGNETIC RANGING**

### **BACKGROUND**

[0001-2] The present disclosure relates to directional drilling and, in particular, to a method of determining a location of a well drilled with respect to an offset well using passive magnetic ranging.

[0003] Efficient extraction of mineral ores in a deep narrow vein can be obtained by drilling multiple parallel open-hole wells at close spacing. Also, extracting petroleum from a reservoir often involves drilling multiple parallel horizontal wells at fairly close spacings to efficiently stimulate and drain the reservoir. In a simple field development scenario, parallel horizontal wells are planned, drilled and completed with sufficient spacing between them that the adjacent well's steel casing is too far away to interfere with the undisturbed earth's magnetic field in the area for the new well. The new well can then be drilled and guided by conventional directional instruments, relying on accelerometers and magnetometers to steer using earth field references. For closer spacing, parallel wells can be planned, drilled, and completed in a step-out pattern, using passive magnetic ranging to steer the drilling of each new well adjacent to the previous cased well, so that the conundrum of magnetic signals from multiple offset wells does not confuse magnetic measurements that are used to steer the drilling of the wells. Passive magnetic ranging is a process for determining a relative position of a well with respect to an offset well which contains multiple residual magnetic poles. The offset well is cased with magnetic casing tubulars which have magnetic field induced therein. A magnetometer on a drill string drilling the new well detects the magnetic field of the tubulars and uses the magnetic field to determine distance and direction to the offset well, as well as to guide the drill string in drilling the new hole in alignment with the offset well. A number of drilling procedures are performed in open wellbores, i.e., wellbores that do not have a casing. In these instances, the offset well does not provide a magnetic field that can be sensed at the drill string in the new well. There is, therefore, a need to provide a method to guide the drilling of a new wellbore next to an open wellbore that is offset from the new well.

[0004] Enhanced Geothermal Systems may employ a closed-loop system of piping which transfers thermal energy by conduction to the pipe, which circulates a fluid for thermal transfer to the surface in a clean, closed loop. Wells drilled to enable such a system are often called "U-Tube Wells", wherein two vertical wells spaced apart are joined deep underground

in a horizontal section. When drilling the U-Tube well, guiding the second well to intersect with the first well uses a method for steering toward an open well.

## **BRIEF DESCRIPTION**

**[0005]** In one aspect, a method of drilling a second well with respect to a first well includes: providing a first drill string in the first well, the first drill string having a magnetic signature; drilling the second well using a second drill string that includes a magnetometer; obtaining a magnetic measurement of the first drill string during drilling of the second well using the magnetometer; and steering the second drill string to drill the second well using the obtained magnetic measurement and the magnetic signature of the first drill string.

**[0006]** In another aspect, a system for drilling a second well with respect to a first well includes: a first drill string in the first well, the first drill string having a magnetic signature; a second drill string in the second well, wherein the second drill string includes a magnetometer that obtains a magnetic measurement of the first drill string while the second drill string drills the second well; and a processor that steers the second drill string to drill the second well using the obtained magnetic measurement and the magnetic signature of the first drill string.

**[0006a]** In another aspect, a method of drilling a third well with respect to a first well and a second well comprises: disposing a first residual magnetic signature along a portion of a tubular string in the first well; disposing a second residual magnetic signature along a portion of a tubular string in the second well; drilling the third well using a drill string that includes a magnetometer; performing, while drilling, a first ranging navigation analysis with respect to magnetometer measurements of the first residual magnetic signature and a second ranging navigation analysis with respect to magnetometer measurements of the second residual magnetic signature, the first ranging navigation analysis having a first uncertainty and the second ranging navigation analysis having a second uncertainty; selecting one of the first ranging navigation analysis and the second ranging navigation analysis based on a comparison of the first uncertainty and the second uncertainty; and steering the drill string to drill the third well using the selected one of the first ranging navigation analysis and the second ranging navigation analysis.

[0006b] In another aspect, a system for drilling a third well with respect to a first well and a second well comprises: a first residual magnetic signature along a portion of a tubular string in the first well; a second residual magnetic signature along a portion of a tubular string in the second well; a drill string in the third well, wherein the drill string includes a magnetometer that obtains magnetic measurements of the first residual magnetic signature and magnetic measurements of the second residual magnetic signature while the drill string drills the third well; and a processor configured to: perform a first ranging navigation analysis with respect to the magnetometer measurements of the first residual magnetic signature and a second ranging navigation analysis with respect to the magnetometer measurements of the second residual magnetic signature, the first ranging navigation analysis having a first uncertainty and the second ranging navigation analysis having a second uncertainty; select one of the first ranging navigation analysis and the second ranging navigation analysis based on a comparison of the first uncertainty and the second uncertainty; and steer the drill string to drill the third well using the selected one of the first ranging navigation analysis and the second ranging navigation analysis.

#### **BRIEF DESCRIPTION OF THE DRAWINGS**

[0007] The following descriptions should not be considered limiting in any way. With reference to the accompanying drawings, like elements are numbered alike:

[0008] FIG. 1 is a schematic diagram of an exemplary drilling system that includes a drill string having a drilling assembly attached to its bottom end that includes a steering unit according to one embodiment of the disclosure;

[0009] FIG. 2 illustrates a drilling system for in-fill drilling that employs ranging from magnetic interference patterns from two offset wells, in one embodiment of the present invention;

[0010] FIG. 3 shows a system for drilling a second wellbore using a first borehole that is an open on non-cased borehole as a guide using passive magnetic tracking;

[0011] **FIG. 4** shows a system for drilling multiple parallel in-fill wells in order to mine ore as drill cuttings from bits drilling multiple parallel wells;

[0012] **FIG. 5** shows a drill-down ream-up method for ore recovery from a reservoir;

[0013] **FIG. 6** illustrates a method of drilling a U-tube well using the passive magnetic ranging techniques disclosed herein;

[0014] **FIG. 7** illustrates a drilling stage of the U-tube well in which the second borehole has been drilled to one side of the first borehole;

[0015] **FIGS. 8 and 9** illustrate subsequent drilling stages for completing the U-tube well according to one embodiment; and

[0016] **FIGS. 10-12** illustrate various stages for drilling a U-tube well in accordance with another embodiment.

## DETAILED DESCRIPTION

[0017] A detailed description of one or more embodiments of the disclosed apparatus and method are presented herein by way of exemplification and not limitation with reference to the Figures.

[0018] **FIG. 1** is a schematic diagram of an exemplary drilling system **100** that includes a drill string having a drilling assembly attached to its bottom end that includes a steering unit according to one embodiment of the disclosure. **FIG. 1** shows a drill string **120** that includes a drilling assembly or bottomhole assembly (“BHA”) **190** conveyed in a borehole **126**, also referred to herein as a well or wellbore. The drilling system **100** includes a conventional derrick **111** erected on a platform or floor **112** which supports a rotary table **114** that is rotated by a prime mover, such as an electric motor (not shown), at a desired rotational speed. A tubing (such as jointed drill pipe) **122**, having the drilling assembly **190** is attached at its bottom end extends from the surface to the bottom **151** of the borehole **126**. A drill bit **150**, attached to drilling assembly **190**, disintegrates the geological formations when it is rotated to drill the borehole **126**. The drill string **120** is coupled to a draw-works **130** via a Kelly joint **121**, swivel **128** and line **129** through a pulley. Draw-works **130** is operated to control the weight on bit (“WOB”). The drill string **120** may be rotated by a top drive (not shown) instead of by the prime mover and the rotary table **114**. The operation of the draw-works **130** is known in the art and is thus not described in detail herein.

[0019] In one aspect, a suitable drilling fluid **131** (also referred to as “mud”) from a source **132** thereof, such as a mud pit, is circulated under pressure through the drill string **120** by a mud pump **134**. The drilling fluid **131** passes from the mud pump **134** into the drill

string **120** via a desurger **136** and the fluid line **138**. The drilling fluid **131a** from the drilling tubular discharges at the borehole bottom **151** through openings in the drill bit **150**. The returning drilling fluid **131b** circulates uphole through the annular space **127** between the drill string **120** and the borehole **126** and returns to the mud pit **132** via a return line **135** and drill cutting screen **185** that removes the drill cuttings **186** from the returning drilling fluid **131b**. A sensor  $S_1$  in line **138** provides information about the fluid flow rate. A surface torque sensor  $S_2$  and a sensor  $S_3$  associated with the drill string **120** provide information about the torque and the rotational speed of the drill string **120**. Rate of penetration of the drill string **120** may be determined from the sensor  $S_5$ , while the sensor  $S_6$  may provide the hook load of the drill string **120**.

**[0020]** In some applications, the drill bit **150** is rotated by rotating the drill pipe **122**. However, in other applications, a downhole motor **155** (mud motor) disposed in the drilling assembly **190** also rotates the drill bit **150**. The rate of penetration (“ROP”) for a given drill bit and BHA largely depends on the WOB or the thrust force on the drill bit **150** and its rotational speed.

**[0021]** A surface control unit or controller **140** receives signals from the downhole sensors and devices via a sensor **143** placed in the fluid line **138** and signals from sensors  $S_1$ - $S_6$  and other sensors used in the system **100** and processes such signals according to programmed instructions provided from a program to the surface control unit **140**. The surface control unit **140** displays desired drilling parameters and other information on a display/monitor **141** that is utilized by an operator to control the drilling operations. The surface control unit **140** may be a computer-based unit that may include a processor **142** (such as a microprocessor), a storage device **144**, such as a solid-state memory, tape or hard disc, and one or more computer programs **146** in the storage device **144** that are accessible to the processor **142** for executing instructions contained in such programs. The surface control unit **140** may further communicate with a remote control unit **148**. The surface control unit **140** may process data relating to the drilling operations, data from the sensors and devices on the surface, data received from downhole and may control one or more operations of the downhole and surface devices.

**[0022]** The drilling assembly **190** also contains formation evaluation sensors or devices (also referred to as measurement-while-drilling, “MWD,” or logging-while-drilling, “LWD,” sensors) determining resistivity, density, porosity, permeability, acoustic properties, nuclear-magnetic resonance properties, corrosive properties of the fluids or formation downhole, salt or saline content, and other selected properties of the formation **195**

surrounding the drilling assembly **190**. Such sensors are generally known in the art and for convenience are generally denoted herein by numeral **165**. The drilling assembly **190** may further include a variety of other sensors and communication devices **159** for controlling and/or determining one or more functions and properties of the drilling assembly (such as velocity, vibration, bending moment, acceleration, oscillations, whirl, stick-slip, etc.) and drilling operating parameters, such as weight-on-bit, fluid flow rate, pressure, temperature, rate of penetration, azimuth, tool face, drill bit rotation, etc.

**[0023]** The drilling assembly may further include a magnetometer **192** for measuring a local magnetic field. The magnetometer **192** may be a three-axis magnetometer for obtaining magnetometer measurements along three orthogonal directions. In an exemplary embodiment, one of the orthogonal directions (i.e., the z-direction) is directed along a longitudinal axis of the drill string and the other orthogonal directions (i.e., the x-direction and y-direction) are in a transverse plane of the drill string and extending radially outward from the drill string. In one embodiment, the magnetometer **192** may measure the local magnetic field to obtain a measurement affected by the presence of a magnetic field on an object in a nearby offset well. These measurements may be sent to controller **140** or other suitable processor that uses the measurements to determine a relative distance between the drill string **120** and the offset well. The drilling assembly may further include survey instruments for obtaining survey parameters, such as borehole inclination and azimuth. In one embodiment, the magnetometer **192** is located proximate drill bit **150**, thereby improving the relevancy of obtained measurements with respect to the drill bit location and therefore the accuracy of the drill bit location. The estimated relative distance may be with respect to a sensor, a BHA, a drill bit or other suitable location of the drill string.

**[0024]** Still referring to **FIG. 1**, the drill string **120** further includes energy conversion devices **160** and **178**. In an aspect, the energy conversion device **160** is located in the BHA **190** to provide an electrical power or energy, such as current, to sensors **165** and/or communication devices **159**. Energy conversion device **178** is located in the drill string **120** tubular, wherein the device provides current to distributed sensors located on the tubular. As depicted, the energy conversion devices **160** and **178** convert or harvest energy from pressure waves of drilling mud which are received by and flow through the drill string **120** and BHA **190**. Thus, the energy conversion devices **160** and **178** utilize an active material (e.g., mud) to directly convert the flow of the active material into electrical energy downhole. Pressure pulses downhole can be sent uphole to communicate with a surface controller. Also pressure pulses from the surface can be sent downhole to communicate with downhole processors. As



depicted, pressure pulses are generated downhole by a modulator, such as a telemetry communication modulator, and/or as a result of drilling activity and maintenance.

Accordingly, the energy conversion devices **160** and **178** provide a direct and continuous source of electrical energy to a plurality of locations downhole without power storage (battery) or an electrical connection to the surface.

**[0025] FIG. 2** illustrates a drilling system **200** for in-fill drilling that employs ranging from magnetic interference patterns from two offset wells, in one embodiment of the present invention. Offset borehole **201** is a horizontal borehole that includes casing string (Casing A) **202** composed of a plurality of casing tubulars. **202a, 202b, 202c...** Offset borehole **203** is a horizontal borehole that includes casing string (Casing B) **204** composed of a plurality of casing tubulars. **204a, 204b, 204c...** Casing B **204** is displaced from Casing A **202** by a known distance and may have been drilled using a range tracking technique (active or passive) based on the magnetic signals from steel Casing A **202**. Casing A **202** extends to production tree **212** at a surface location, while Casing B **204** extends to production tree **214** at another surface location. The casing tubulars **202a, 202b** and **202c** of Casing A **202** have magnetic profiles associated with them. A magnetic profile (also referred to herein as a “magnetic signature”) refers to a particular magnetic charge pattern, shape, polarity, number of poles, etc. for an object such as a casing, casing tubular, drill string, drill string tubular, BHA, etc. The magnetic profile of a casing tubular is generally similar, but unique in details to other casing tubulars and therefore distinguishes the casing tubular from the other casing tubulars of its casing string. The casing tubulars **204a, 204b** and **204c** of Casing B **204** also have magnetic profiles associated with them. Casing A **202** has a magnetic profile based on the magnetic profiles of its casing tubulars **202a, 202b, 202c...**, their arrangement, order, etc. Similarly, Casing B **204** has a magnetic profile based on the magnetic profiles of its casing tubulars **204a, 204b, 204c...**, their arrangement, order, etc. The magnetic profile of Casing A **202** is therefore different from the magnetic profile of Casing B **204**. In one aspect, the casing tubulars **202a, 202b, 202c...** can be arranged so that a magnetic pole of one casing tubular interferes with a magnetic pole of its adjacent casing tubular. For example, adjacent casing tubulars can be joined at a joint so that the magnetic pole of one tubular at the joint is the same as the magnetic field of the adjacent tubular at the joint, thereby causing magnetic fields to extend into the formation at the joint. These extending fields can be more easily detected by a magnetometer on a nearby drill string and used in magnetic ranging by the drill string.

[0026] Drilling rig **210** is located between production tree **212** and production tree **214** and extends a drill string **208** into a borehole **206** located between the two existing offset wells **201** and **203** in order to drill borehole **206**. The drill string **208** includes a drill bit **220** for drilling the borehole **206**, a motor and steering assembly **222** for drilling and steering the drill bit **220**, and a magnetometer **224** for magnetic ranging of the borehole **206** with respect to Casing A **202** and Casing B **204**. In other embodiments, steering assembly **222** may be a rotary steerable system to steer the bit, relying on rotation from the surface to provide torque. In various embodiments, the magnetometer **224** may include various single axis magnetometers aligned along orthogonal directions of a coordination system of the drill string **208**. The magnetometers detect distortions in the earth's magnetic field due to the proximity of drill string **208** to casing **202** and **204**. A processor **226** receives magnetic measurements from the magnetometer **224**, which are distorted due to the proximity of the adjacent casing. The MWD system telemeters the distorted magnetic field data to the surface, where another processor, with knowledge of the depth of the drilling assembly, is continuously computing the ranging measurements. In one embodiment, the surface processor employs a Passive Magnetic Ranging (PMR) method using a trailing Extended Kalman Filter (EKF) optimization window to estimate the position and attitude of the well **206** in 3-dimensional space. The surface processor thereby determines distances and directions from the borehole **206** to Casing A **202** and from borehole **206** to Casing B **204**. The surface processor then uses these distances and the confidence factors (or uncertainties) associated with the distances to produce guidance instructions to steer the drill bit **220** along the planned well path. In one embodiment, the surface processor sends a signal to the motor and steering assembly **222** to alter a drilling or steering parameter with respect to the drill bit **220** based on the determined distances.

[0027] In one embodiment, the drill string **208** performs magnetic ranging using the magnetic fields from both Casing A **202** and Casing B **204**. By performing a ranging navigation analysis on both Casing A **202** and Casing B **204** simultaneously while drilling borehole **206**, it is possible to continuously visualize the range and direction (and their uncertainties) to each of the offset wells **201** and **203**. The methods disclosed herein add the trajectory and magnetic profile estimate of a second offset well (e.g., Casing B **204**) to the standard ranging techniques used to drill parallel to a single first offset well (e.g., Casing A **202**). In each of the side-by-side tracking analyses, a continuous estimate for range uncertainty, direction uncertainty and goodness of fit for the predicted and measured magnetic field is computed and displayed. In depth segments where the magnetic field is

stronger due to proximity or pole strength, one of the simultaneous analysis cases will be the clear choice to represent the true position of drill string **208**. By replicating the tracking analysis against both offset wells **201** and **203** simultaneously and aggregating best-fit results over multiple casing lengths, it is possible to determine the position of the current wellbore **206** against at least one of the offset wells **201** and **203**. Once a position with respect to either Casing A **202** or Casing B **204** is determined, the position with respect to the other casing is calculated, given prior knowledge of their displacement from the trajectories of the two offset casing strings.

**[0028]** While drilling the current wellbore **206**, the magnetic signals from one of the offset wellbores **201** and **203** will generally be stronger than the other. The uncertainty in position measurements will be greater for measurements of the offset well that has a weaker magnetic field at the magnetometer **224**. However, the position of the drill string **208** can still be known adequately to enforce anti-collision rules for borehole drilling.

**[0029]** Weak casing signals cause little disturbance to the ambient Earth's magnetic field. In one embodiment, the processor **226** can perform conventional magnetic surveys for guidance off of a single offset wellbore. Stronger magnetic signals from the casings **202** and **204**, (due to close proximity of one of more offset wells) provide better confidence in the range and direction to the offset well or wells. Because the ranging process is continuous with depth, and because the magnetic poles on the adjacent parallel joints of casing are not correlated with depth, it is possible to distinguish magnetic trends over a selected segment of the wellbore, and therefore to determine a range and direction to each of the offset wells, with a fair degree of confidence. In one embodiment, the drill string **208** splits a difference between offset wells **201** and **203** to guide the drilling of horizontal well **206**. In another embodiment, a history of the magnetic fields can be recorded over a selected tracking length. In various embodiments, this tracking length is about 60 meters. In similar fashion, more than two adjacent casing strings can be loaded into the three-dimensional simulation and analysis processor, and tracked continuously in simultaneous algorithms over depth intervals. Where the correlation calculations indicate strong confidence, the position for the active well can be chosen from the available choices accordingly.

**[0030]** **FIG. 3** shows a system **300** for drilling a second wellbore **304** using a first borehole **302** (also referred to herein as an “offset borehole” or “reference borehole”) that is an open on non-cased borehole as a guide using passive magnetic tracking. The second borehole **304** is being drilled alongside the first borehole **302** at a location laterally displaced from the first borehole **302**. The two wellbores **302** and **304** are shown in **FIG. 3** as being

drilled from two separate derricks **306** and **308**, respectively, but they may also be drilled using the same rig. First borehole **302** and second borehole **304** are shown as horizontal boreholes for illustrative purposes. However, it is understood that a vertical borehole or boreholes having any angle of deviation can be drilled using the methods disclosed herein. Furthermore, conventional derricks **306** and **308** may alternatively be replaced by horizontal directional drilling slant hole drilling rigs typically used in mining applications.

**[0031]** Drilling a borehole parallel to and closely spaced to an existing open hole borehole using conventional magnetic MWD guidance systems becomes difficult with increasing depth. This is because the borehole trajectories are computed from a series of discrete stations at which only the attitude (inclination and direction angles) and depth are known. Thus, the uncertainty of the location of the well increases with depth. With closely-spaced parallel wells, the cones of uncertainty can overlap at a relatively shallow depth. In order to drill the second well **304** accurately spaced with respect to first well **302**, additional information is needed about their positions in space. Passive Magnetic Ranging can be used to supply the additional information needed to accurately position new wells in proximity to existing wells according to a plan.

**[0032]** A drill string (“first drill string”) **310** that drills the first wellbore **302** is composed of a plurality of steel tubulars **310a**, **310b**, **310c**, **310d**, ... joined end to end to form the drill string **310**. Each tubular **310a**, **310b**, **310c**, **310d**, ... is added to the drill string **310** at a surface location as the drill string **310** descends into the first wellbore **304**. Each tubular **310a**, **310b**, **310c**, **310d**, ... has a magnetic field or magnetic charge associated with them. The magnetic charge can be characterized by the strength of the magnetic field on the tubular, the distribution of the magnetic charge on the tubular, the magnetic polarity, etc. The magnetic field or magnetic charge can be a residual magnetic charge imparted to them at the uphole location, either through an intended magnetization process or via an incidental magnetization. The residual charge may be measured or estimated at the uphole location and the measurements stored in a memory location such as storage device **144** (**FIG. 1**). As the tubulars **310a**, **310b**, **310c**, **310d**, ... are added to the drill string **310**, the order of the tubulars **310a**, **310b**, **310c**, **310d**, ... and their locations along the drill string **310** can be also stored in the memory location. Thus, a profile of the magnetic field produced by the drill string **310** (the “magnetic profile”) is obtained. The magnetic profile may be stored at a memory location and then used to guide the drilling of subsequent wells using the methods disclosed herein. In one embodiment, all of the tubulars **310a**, **310b**, **310c**, **310d**... are magnetically charged. In another embodiment, the offset drill string **310** may be constructed so that only one

or a few tubulars have a significant magnetic charge. Since the magnetic field emanating from a steel tubular is stronger for larger diameter tubulars, and since these are commonly deployed near the bit in the bottom hole assembly (BHA) portion of the drill string, it may be that the “magnetic profile” of interest is located within one or more tubular sections of the BHA near the bit.

**[0033]** In one embodiment, the first wellbore **302** is an open borehole with no casing. Therefore, the first wellbore **302** has no magnetic field except for the magnetic field provided by the drill string **310**. After drilling first borehole **302**, drill string **310** can be left in first wellbore **302** temporarily for the purposes of providing an offset well for ranging, after which the drill string **310** can be moved. Drill string (“second drill string”) **312** in the second wellbore **304** can then use the magnetic profile of the drill string **310** for magnetic ranging to drill the second wellbore **304**. As opposed to active magnetic ranging, in which an alternating magnetic field is produced by rotating the magnetic field (mechanically or electrically), with PMR there is no need to rotate the offset drill string in order to detect the magnetic profile. Furthermore, because the radial distribution of the magnetic field at the pole locations is generally symmetrical, rotation of drill string **310** does not materially affect the measured magnetic field at drill string **312**.

**[0034]** The second borehole **304** is drilled with drill string **312** which includes one or more sensors, such as a magnetometer **314** and survey instruments. Processor **316** or any other suitable processor computes the measured local magnetic fields which are distorted due to the proximity of the adjacent casing. The MWD system telemeters the distorted magnetic field data to the surface, where another processor, with knowledge of the depth of the drilling assembly, is continuously computing the ranging measurements. In one embodiment, the surface processor employs a Passive Magnetic Ranging (PMR) method using a trailing Extended Kalman Filter (EKF) optimization window to determine relative location and/or orientation of the magnetometer **314** with respect to the drill string **310** in first borehole **302** and then uses the determined location and/or orientation to control a rotary steerable system at the bit or orient a top drive in order to drill the well **312** along a selected or planned well path **330**. Alternatively, an operator can control and/or orient the top drive to position an adjustable motor and steerable device downhole using the determined location and/or orientation. In operation, the surface processor estimates a charge distribution at the drill string **310** that produces the downhole measurements at magnetometer **312**. The estimated charge distribution is then compared to the known charge profile of drill string **310** to determine orientation and location of drill string **312** with respect to drill string **310**. In one

embodiment the measurements of the magnetic field are maintained to form a record of magnetic field measurements over a selected length trailing behind the magnetometer. Thus a magnetic profile is recorded at the surface processor which then compares the recorded magnetic profile to the known magnetic profile in order to find relative position of the drill string **312** with respect to drill string **310**.

**[0035]** In one embodiment, drill string **310** can be placed in the first well **302** and the drill string **312** can drill the second wellbore **304** by measuring magnetic fields from drill string **310** and determining the location between drill string **312** and drill string **310** based on the measured magnetic fields. Once the second wellbore **304** has been drilled to its desired depth, the drill string **310** can be moved within the first wellbore **302** or tripped out of first wellbore **302**.

**[0036]** In another embodiment, the first drill string **310** can be placed into the first well **302** at a first depth. The second drill string **312** can then drill the second well **304** to a first selected depth using the magnetic signature of the first drill string **310**. The first drill string **310** can then be moved to a second depth in the first wellbore **302** and the second drill string **312** can drill the second wellbore **304** to a second selected depth. When drilling to the second selected depth, the second drill string **312** guides off of the same tubulars of the first drill string **310** that was used to drill to the first depth. Therefore, the magnetic signature measurements obtained by magnetometer **314** while drilling to the first selected depth can be stored and used to verify measurements obtained while drilling to the second selected depth or to otherwise improve the ability of the second drill string **312** to guide off of first drill string **310**. Therefore, the first wellbore **310** and the second wellbore **304** can be drilled side-by-side by drilling the first well **302** to a first depth, drilling the second well **304** to a first selected depth, drilling the first well **302** to a second depth, drilling the second wellbore **304** to the second selected depth, etc.

**[0037]** Additionally, the first drill string **310** may include a magnetic sub **328** that produces an identifiable magnetic profile when the magnetic sub **328** is rotating. The second drill string **312** can then perform magnetic ranging with respect to the rotating magnetic sub **328** to drill the second well **304** along a planned well path **330**. This method is known in the art as active magnetic ranging with a rotating magnet sub above one drill bit, and a wireline-deployed magnetometer moved to track its progress incrementally in an adjacent cased well.

**[0038]** In another embodiment, both the first drill string **310** and the second drill string **312** can be composed of magnetic drilling tubulars. Thus, the first drill string can obtain magnetic measurements related to a magnetic profile of the second drill string **312**

using magnetometer **324**. A processor on the first drill string **310** can then use the obtained magnetic measurements to perform ranging of the first drill string **310** with respect to the second drill string **312**, which can be used to steer the first drill string **310**. Additionally, the first drill string **310** can be tripped out of the first wellbore **310** and used to drill a third well (not shown) using the magnetic signature from the second drill string **312**. This pattern of step-out drilling can be continued indefinitely in a leap-frog manner.

**[0039] FIG. 4** shows a system for drilling multiple parallel in-fill wells in order to mine ore as drill cuttings from bits drilling multiple parallel wells. In mine ore drilling, wells are drilled for excavation purposes and thus are drilled as close to each other as possible in order to excavate as much of the ore as possible. In **FIG. 4**, Well 2 (**404**) is been drilled down to a selected depth with a pilot bit using a rig such as Rig A (**410**). The drill string is then tripped out of Well 2 (**404**) and moved over to a next well location Well 1 (**402**). Well 2 (**404**) is too close to Well 1 (**402**) for magnetic ranging, as indicated by the magnetic fields of Well 1 (**402**). For example, there may not be enough room between Well 2 (**404**) and Well 1 (**402**) to allow for side-by-side physical placement of two rigs at the surface associated with Well 2 (**404**) and Well 1 (**402**). Also, the magnetic signal from Well 1 (**402**) may be too strong for reliable magnetic ranging techniques at the close proximity to Well 2 (**404**) for drilling of Well 2 (**404**). Therefore, rather than drilling wells sequentially using magnetic ranging, a leap-frog method may be selected. For example, Well 2 (**404**) can have been drilled previously using a drill string in Well 0 (not shown) Well 3 (**406**) is drilled alongside Well 2 (**404**) using the drill string in Well 1 (**402**). A subsequent Well 4 (not shown) can be drilled alongside Well 3 (**406**) by placing a drill string in Well 2 (**404**), and a Well 5 (not shown) can be drilled alongside Well 4 (not shown) by placing a drill string in Well 3 (**406**). The drill string **408** of Well 1 (**402**) includes drilling tubulars which provide a magnetic signature that can be used for magnetic ranging. Drill string **414** drills Well 3 (**406**) using magnetic ranging methods based on the magnetic signature of drill string **408** in Well 1 (**402**). This leap-frog method can be useful in precious ore mining where wells are drilled so as to be immediately adjacent to one another.

**[0040] FIG. 5** shows a drill-down ream-up method for ore recovery from a reservoir. Drill string **408** in Well 1 (**402**) provides a magnetic signature for magnetic ranging of drill string **414** in Well 3 (**406**). Drill string **408** includes an expandable reamer to enlarge the Well 1 (**402**) as the drill string **408** is tripped out of the Well 1 (**402**). In various embodiments, the expandable reamer is a 24-inch reamer and therefore expands the Well 1 (**402**) to 24 inches in diameter. Therefore, drill string **408** drills downward using the pilot bit

(12 inches) and then reams upward using the reamer bit (24 inches). Reaming upward expands an amount of in-situ ore volume that is retrieved into small cuttings that can be used for smelting. As drill string **408** is tripped upward, a computer or processor, generally at the surface, tracks the depth in both Well 1 (**402**) and Well 3 (**406**). The processor adjusts the location of the expected magnetic signature of the drill string **408** in Well 1 (**402**) in order to help guide the drilling of Well 3 (**406**). The drill string **408** can therefore both ream and provide a magnetic signature for drill string **414**, with the reaming and the providing of the magnetic signature occurring simultaneously.

**[0041] FIG. 6** illustrates a method of drilling a U-tube well using the passive magnetic ranging techniques disclosed herein. The U-tube well is created by drilling a first well **602** using a first drill string **604** extending from a rig **606** at a first location **608**. A second well **612** is drilled using a second drill string **614** extending from a rig **616** at a second location **618** separate from the first location **608**. The first well **602** and second well **612** are drilled to a selected vertical depth and then turned so as to drill horizontally so that the first well **602** and the second well **612** are approximately at the same depth and are drilled to intersect each other. The intent of this drilling method is to having the second well **612** aligned with the first well **602** and anti-parallel (i.e., parallel but 180° out of alignment) to the first well. The planned path of the second well **612** is such that the second well **612** can be drilled so that drill bit **622** drills directly into drill bit **620**, without, of course, causing damage to drill bit **620**. Drill bit **620** can be backed off to accommodate drill bit **622**. Usually however, the second well **612** is not collinear with the first well **602** due to various difficulties with controlling direction and uncertainty of the precise well positions. Therefore, the second well **612** will end up being drilled to one side of the first well **602**. The first drill string **604** includes magnetic tubular sections that provide a magnetic profile that can be measured by a magnetometer **624** of second drill string **614**. Additionally, a magnetometer in drill string **604** can use passive magnetic ranging and the magnetic profile from drill string **614** to confirm the well positions.

**[0042] FIG. 7** illustrates a drilling stage in which the second borehole **612** has been drilled to one side of the first borehole **602**. The magnetometer **624** measures and records the magnetic profile of the first drill string **604** as the second well **612** is drilled alongside the first well **602**. The magnetometer measurements can then be used to calculate a range and direction from the drill string **614** to drill string **604**. A corrective action can then be determined from the magnetometer measurements to bring the path of the second well **612**



back into a desired alignment with the path of the first well **602** alongside planned well path **630**.

**[0043] FIGS. 8 and 9** illustrate subsequent drilling stages for completing the U-tube well according to one embodiment. In **FIG. 8**, once the distance and orientation of the second drill string **614** has been determined with respect to the first drill string **604**, the second drill string **614** is tripped up through the second well **612** to a retracted position so that the path of the second drill string **614** at the retracted position is once again collinear with the first well **602**. In **FIG. 9**, the second drill string **614** steers (i.e., sidetracks) the drill bit **622** in order to drill along the planned well path **630**. The first drill string **604** has been retracted into the first borehole **602** so that the second drill string **614** will not collide with the first drill string **604** when it enters the first borehole **602**.

**[0044] FIGS. 10-12** illustrate various stages for drilling a U-tube well in accordance with another embodiment. Drill string **1004** drills the first well **1002** to a selected vertical depth and then proceeds to drill the first well **1002** horizontally. Drill string **1014** drills second well **1012** to the selected depth and then proceeds to drill the second well **1012** horizontally along a planned well path **1030** that is anti-parallel and collinear with the horizontal section of first well **1002**. The second drill string **1014** is a casing/liner drill string that builds or drills in a casing **1016** in the second well **1012** while drilling the second well **1012**. Second drill string **1014** further includes a magnetometer **1020** for detecting, among other things, the magnetic field of the drilling tubulars of first drill string **1004**. In **FIG. 10**, drill string **1014** has begun to deviate from the planned well path.

**[0045] In FIG. 11**, drill string **1014** drills alongside first well **1002** due to the deviation from the planned well path **1030** that is illustrated in **FIG. 10**. The magnetometer **1020** of the second drill string **1014** measures the magnetic field of the drilling tubulars of the first drill string **1004** as the second drill string **1014** drills alongside the first drill string **1004**. The measured magnetic fields are then used to calculate the range between first well **1002** and second well **1012**.

**[0046] In FIG. 12**, the second drill string **1014** has used the calculated range in order to steer the second drill string **1014** into the first well **1002** from a side of the first well **1002**. Because the casing is deployed as the well **1012** is drilled, drill string **1014** cannot be retracted back up the second well **1012** to optimize the intersection path during drilling corrections. It must drill forward and effect the intersection with first well **1002**, keeping deviations in the trajectory to a minimum. In one embodiment, a mechanical coupling device such as a latch **1024**, which can be a swiveling latch, can be used to attach the drill bit **1020**

of the first drill string **1004** to the drill bit **1022** of the second drill string **1014**. Therefore, the first drill string can be used to pull the second drill string **1014** through the first well **1002** as the first drill string trips out of the first well **1002**. This allows the second drill string **1014** to complete a casing and lining operation over the entire U-type well, using a single continuous casing string. This method avoids a casing joining operations at deep, inaccessible points and provides a smooth, continuous inside diameter for traversal by a heat transfer medium fluid. Heat transfer medium fluid may include liquids or gases, including but not limited to water, steam, and carbon dioxide.

**[0047]** In various embodiments, offset wells used in the magnetic ranging methods disclosed herein need not be horizontal. Rather the offset wells can be vertical or have any other inclination, just so that they are approximately parallel to a planned well. In other embodiments, infill well plans do not need to be centered to "split the difference" between existing wells and can be planned so that wells are as close as about 1 meter and distributed in a step-out pattern. More than two adjacent wells could also be initialized in three-dimensional space and analyzed simultaneously as depth progresses.

**[0048]** The methods disclosed herein therefore provide setup and operation of two or more continuous Passive Magnetic Ranging tasks simultaneously against two or more adjacent parallel wells. These methods enable closer spacing for initial field development of "manufactured horizontal wells" in Steam Assisted Gravity Drainage (SAGD) or shale plays, and allow infill wells to be drilled that previously would require gyroscopic guidance.

**[0049]** Therefore in one aspect, the present invention provides a method of drilling a second well with respect to a first well. The method includes: providing a first drill string in the first well, the first drill string having a magnetic signature; drilling the second well using a second drill string that includes a magnetometer; obtaining a magnetic measurement of the first drill string during drilling of the second well using the magnetometer; and steering the second drill string to drill the second well using the obtained magnetic measurement and the magnetic signature of the first drill string. A distance determined between the first well and the second well and confidence factors associated with the distance may be used to produce a guidance instruction for steering the second drill string along a planned well path. In one embodiment, the first drill string is removed from the first well after drilling the second well. In another embodiment, first drill string is moved within the first well while the second drill string obtains the magnetic measurement of the first drill string and drills the second well. In yet another embodiment, the method includes drilling the second well when the first drill string is at a first depth in the first well, moving the first drill string from the first depth to a

second depth in the first well while the second drill string is not drilling, and resuming drilling the second well when the first drill string is at the second depth in the first well. The second drill string can be steered along a planned path using passive magnetic ranging. In one embodiment, a third well is located between the first well and the second well. The second well can be drilled so as to be aligned with the first well and drilled anti-parallel to the first well in order to intersect the first well. In this drilling configuration, the first drill string can be attached to the second drill string and the second drill string can be pulled through the first well via the first drill string. In various embodiments, the first drill string also includes a magnetometer in order to measure a magnetic signature of the second drill string.

**[0050]** In another aspect, the present invention provides a system for drilling a second well with respect to a first well. The system includes a first drill string in the first well, the first drill string having a magnetic signature; a second drill string in the second well, wherein the second drill string includes a magnetometer that obtains a magnetic measurement of the first drill string while the second drill string drills the second well; and a processor that steers the second drill string to drill the second well using the obtained magnetic measurement and the magnetic signature of the first drill string. The processor uses a distance determined between the first well and the second well and confidence factors associated with the distance to produce a guidance instruction for steering the second drill string along a planned well path. In one embodiment, the first drill string is removable from the first well after the second well has been drilled. In another embodiment, the first drill string moves within the first well while the second drill string obtains the magnetic measurement of the first drill string and drills the second well. In another embodiment, the second drill string drills the second well with the first drill string at a first depth in the first well, refrains from drilling while the first drill string is moved from the first depth to a second depth in the first well, and resumes drilling of the second well with the first drill string at the second depth in the first well. The processor steers the second drill string along a planned path using passive magnetic ranging. The system of claim 11, wherein a third well is located between the first well and the second well. In one embodiment, the second well is aligned with the first well and drilled anti-parallel to the first well to intersect the first well. The second drill string may include a mechanical coupling device for attaching the second drill string to the first drill string to allow the first drill string to pull the second drill string through the first well. In one embodiment, the first drill string includes a magnetometer that measures a magnetic signature of the second drill string.

[0051] The use of the terms “a” and “an” and “the” and similar referents in the context of describing the invention (especially in the context of the following claims) are to be construed to cover both the singular and the plural, unless otherwise indicated herein or clearly contradicted by context. Further, it should further be noted that the terms “first,” “second,” and the like herein do not denote any order, quantity, or importance, but rather are used to distinguish one element from another. The modifier “about” used in connection with a quantity is inclusive of the stated value and has the meaning dictated by the context (e.g., it includes the degree of error associated with measurement of the particular quantity).

[0052] While the invention has been described with reference to an exemplary embodiment or embodiments, it will be understood by those skilled in the art that various changes may be made and equivalents may be substituted for elements thereof without departing from the scope of the invention. In addition, many modifications may be made to adapt a particular situation or material to the teachings of the invention without departing from the essential scope thereof. Therefore, it is intended that the invention not be limited to the particular embodiment disclosed as the best mode contemplated for carrying out this invention, but that the invention will include all embodiments falling within the scope of the claims. Also, in the drawings and the description, there have been disclosed exemplary embodiments of the invention and, although specific terms may have been employed, they are unless otherwise stated used in a generic and descriptive sense only and not for purposes of limitation, the scope of the invention therefore not being so limited.

**What is claimed is:**

1. A method of drilling a third well with respect to a first well and a second well, the method comprising:

disposing a first residual magnetic signature along a portion of a tubular string in the first well;

disposing a second residual magnetic signature along a portion of a tubular string in the second well;

drilling the third well using a drill string that includes a magnetometer;

performing, while drilling, a first ranging navigation analysis with respect to magnetometer measurements of the first residual magnetic signature and a second ranging navigation analysis with respect to magnetometer measurements of the second residual magnetic signature, the first ranging navigation analysis having a first uncertainty and the second ranging navigation analysis having a second uncertainty;

selecting one of the first ranging navigation analysis and the second ranging navigation analysis based on a comparison of the first uncertainty and the second uncertainty; and

steering the drill string to drill the third well using the selected one of the first ranging navigation analysis and the second ranging navigation analysis.

2. The method of claim 1, wherein the first uncertainty and the second uncertainty are at least one of a range uncertainty and a direction uncertainty.

3. The method of claim 1 or 2, further comprising performing the first ranging navigation analysis and the second ranging navigation analysis continuously with depth.

4. The method of any one of claims 1 to 3, further comprising moving at least one of the first residual magnetic signature within the first well and the second residual magnetic signature within the second well while obtaining the magnetic measurement of at least one of the first residual magnetic signature and the second residual magnetic signature and while the drill string drills the third well.

5. The method of any one of claims 1 to 3, further comprising:
  - drilling the third well when the first residual magnetic signature is at a first depth in the first well;
  - moving the first residual magnetic signature from the first depth to a second depth in the first well while the drill string is not drilling; and
  - resuming drilling the third well when the first residual magnetic signature is at the second depth in the first well.
  
6. The method of any one of claims 1 to 3, further comprising steering the drill string along a planned path using passive magnetic ranging.
  
7. The method of any one of claims 1 to 6, wherein the third well is located between the first well and the second well.
  
8. The method of claim 1, further comprising using a trailing extended Kalman filter optimization window to estimate a position and attitude of the third well in three-dimensional space.
  
9. The method of any one of claims 1 to 3, wherein the first residual magnetic signature is provided by an offset drill string in the first well, and the method further comprises:
  - drilling the third well based on the first residual magnetic signature;
  - removing the offset drill string from the first well and placing the offset drill string in the third well; and
  - drilling a subsequent well based on the first residual magnetic signature provided by the offset drill string in the third well.
  
10. The method of any one of claims 1 to 8, further comprising measuring a residual magnetic signature of the drill string using a magnetometer in the first well.

11. A system for drilling a third well with respect to a first well and a second well, the system comprising:

a first residual magnetic signature along a portion of a tubular string in the first well;

a second residual magnetic signature along a portion of a tubular string in the second well;

a drill string in the third well, wherein the drill string includes a magnetometer that obtains magnetic measurements of the first residual magnetic signature and magnetic measurements of the second residual magnetic signature while the drill string drills the third well; and

a processor configured to:

perform a first ranging navigation analysis with respect to the magnetometer measurements of the first residual magnetic signature and a second ranging navigation analysis with respect to the magnetometer measurements of the second residual magnetic signature, the first ranging navigation analysis having a first uncertainty and the second ranging navigation analysis having a second uncertainty;

select one of the first ranging navigation analysis and the second ranging navigation analysis based on a comparison of the first uncertainty and the second uncertainty; and

steer the drill string to drill the third well using the selected one of the first ranging navigation analysis and the second ranging navigation analysis.

12. The system of claim 11, wherein the first uncertainty and the second uncertainty are at least one of a range uncertainty and a direction uncertainty.

13. The system of claim 11 or 12, wherein the processor is configured to perform the first ranging navigation analysis and the second ranging navigation analysis continuously with depth.

14. The system of any one of claims 11 to 13, wherein at least one of the first residual magnetic signature moves within the first well and the second residual magnetic signature moves within the second well while the drill string obtains the magnetic

measurements of at least one of the first residual magnetic signature and the second residual magnetic signature and drills the third well.

15. The system of any one of claims 11 to 13, wherein the drill string drills the third well with the first residual magnetic signature at a first depth in the first well, refrains from drilling while the first residual magnetic signature is moved from the first depth to a second depth in the first well, and resumes drilling of the third well with the first residual magnetic signature at the second depth in the first well.

16. The system of any one of claims 11 to 13, wherein the processor is configured to steer the drill string along a planned path using passive magnetic ranging.

17. The system of any one of claims 11 to 16, wherein the third well is located between the first well and the second well.

18. The system of claim 11, wherein the processor is configured to use a trailing extended Kalman filter optimization window to estimate a position and attitude of the third well in three-dimensional space.

19. The system of any one of claims 11 to 18, wherein the first well includes a magnetometer that measures a residual magnetic signature of the drill string in the third well.



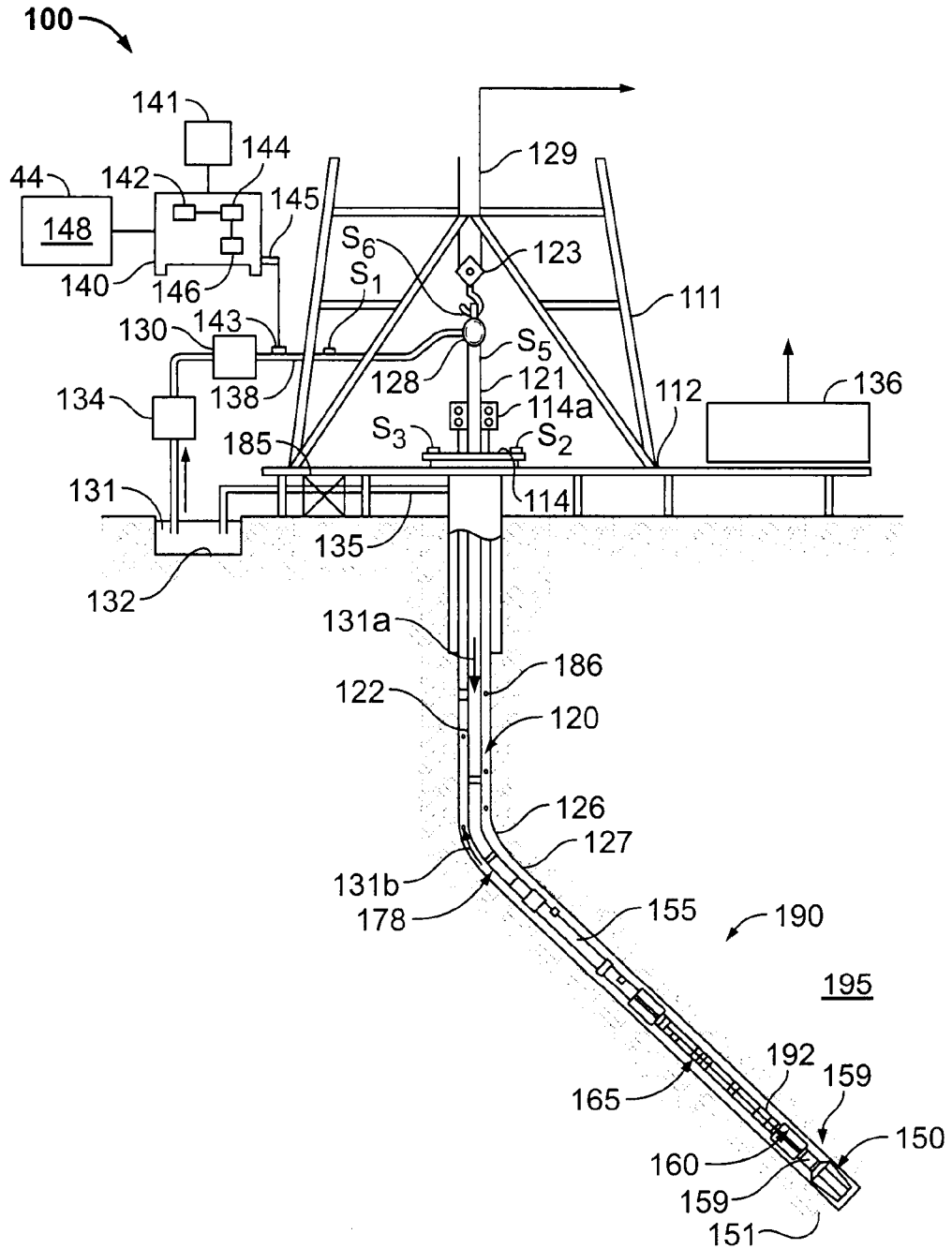

FIG. 1

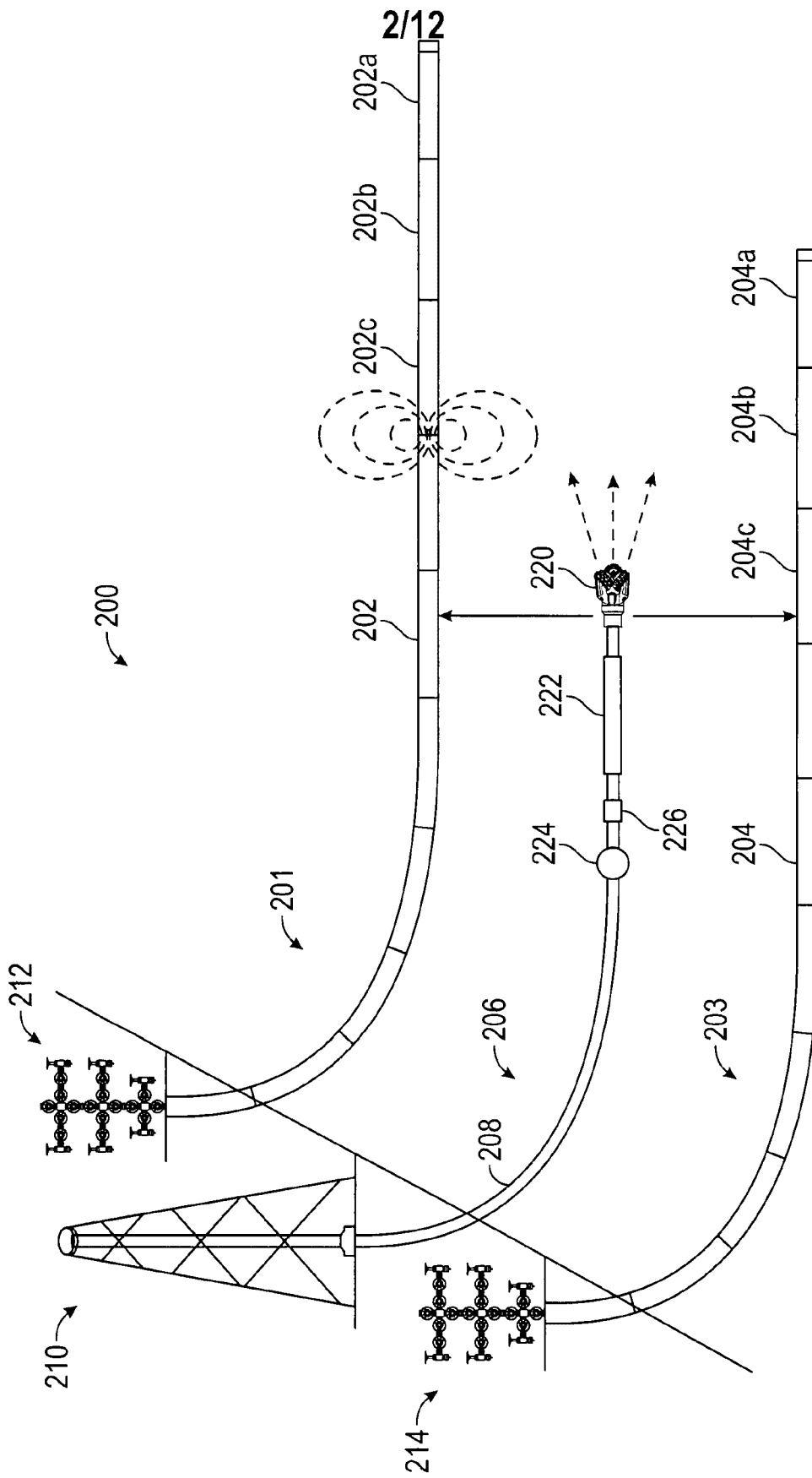

FIG. 2

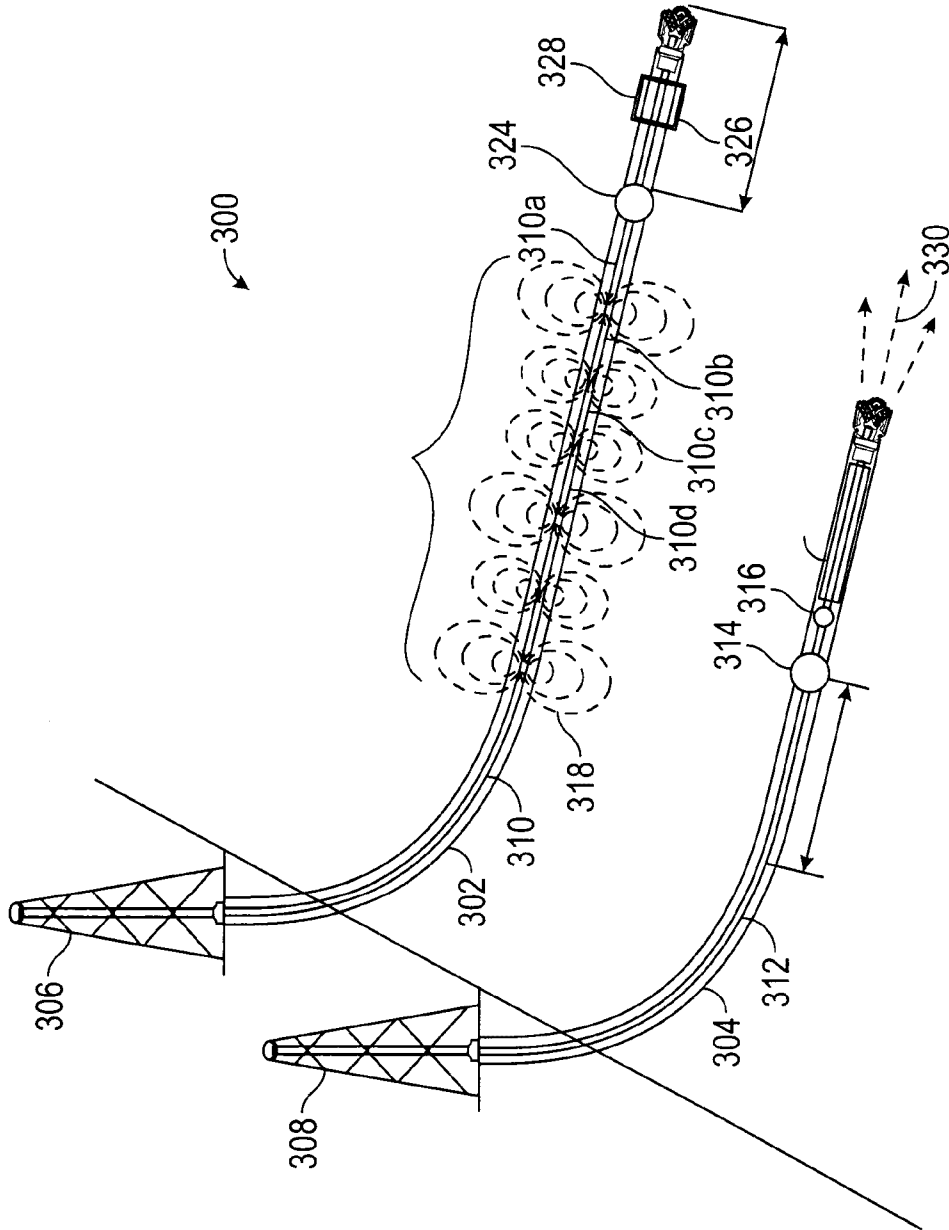

FIG. 3

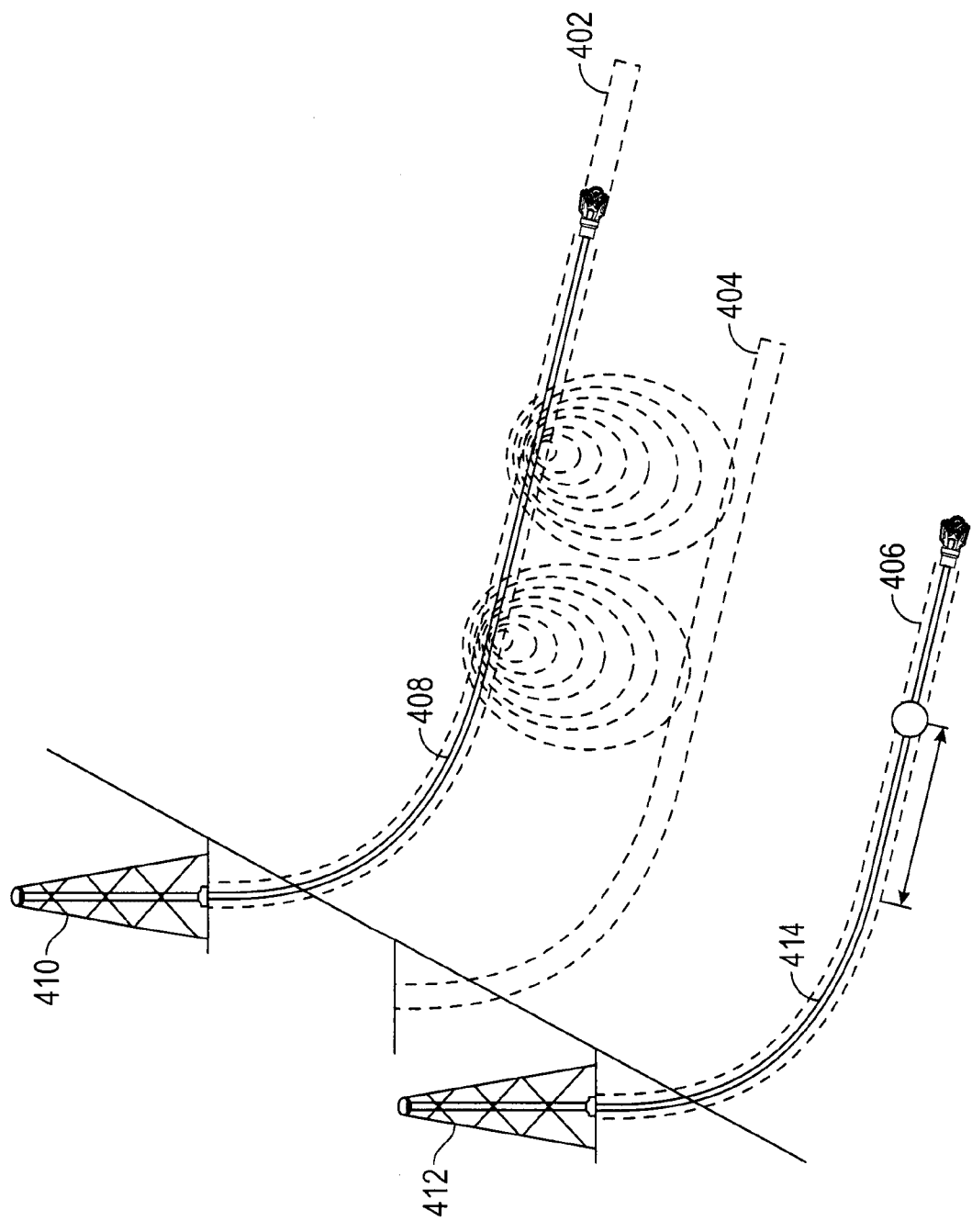

FIG. 4

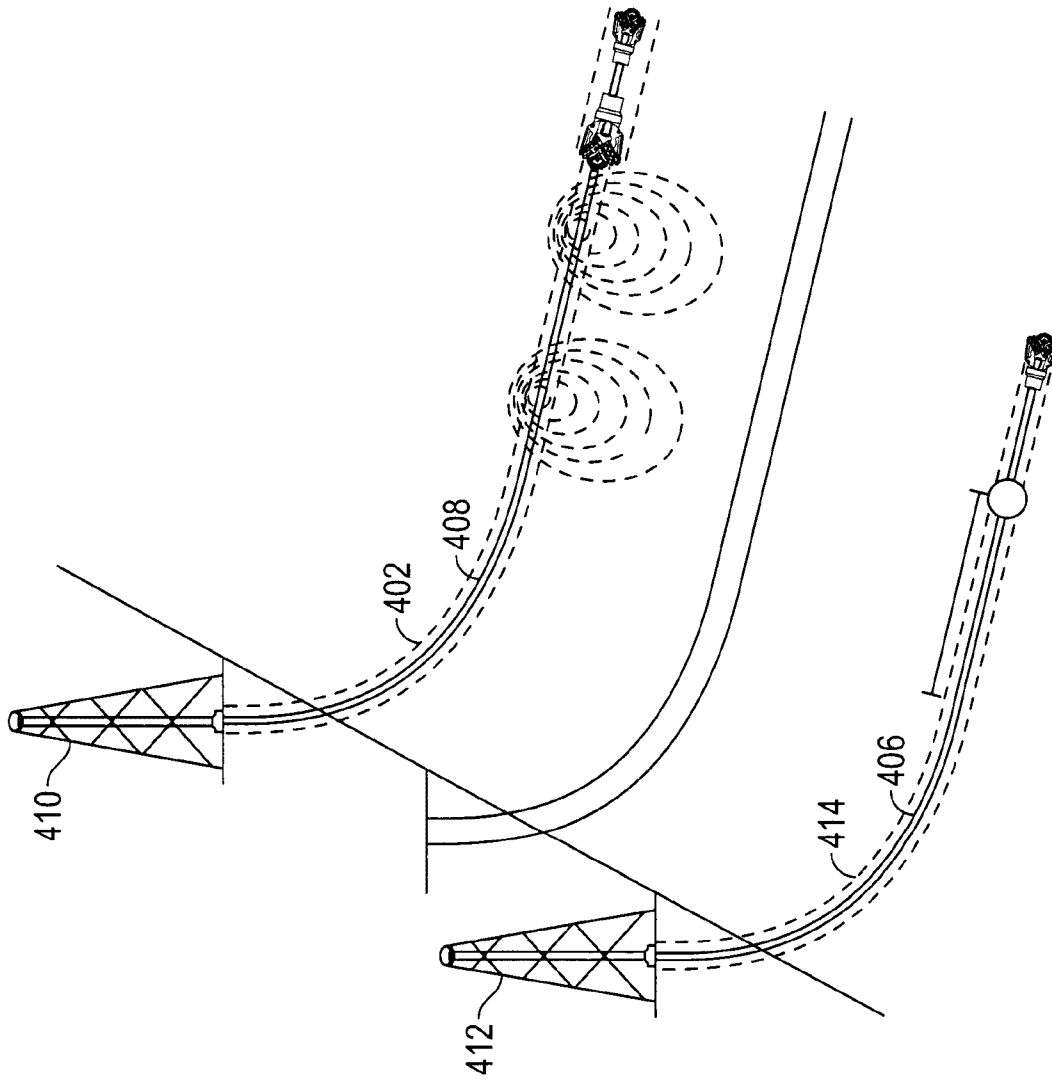

FIG. 5

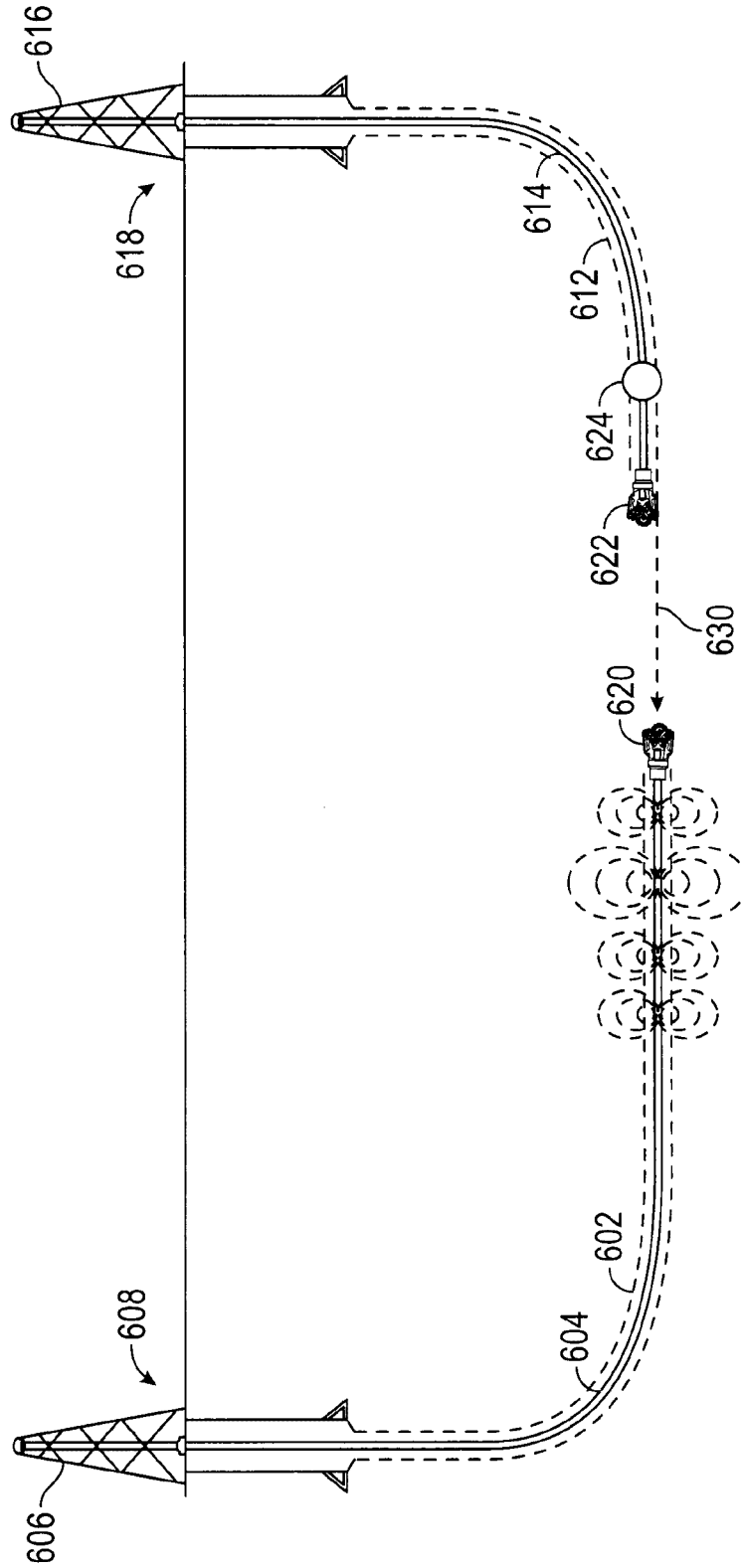

FIG. 6

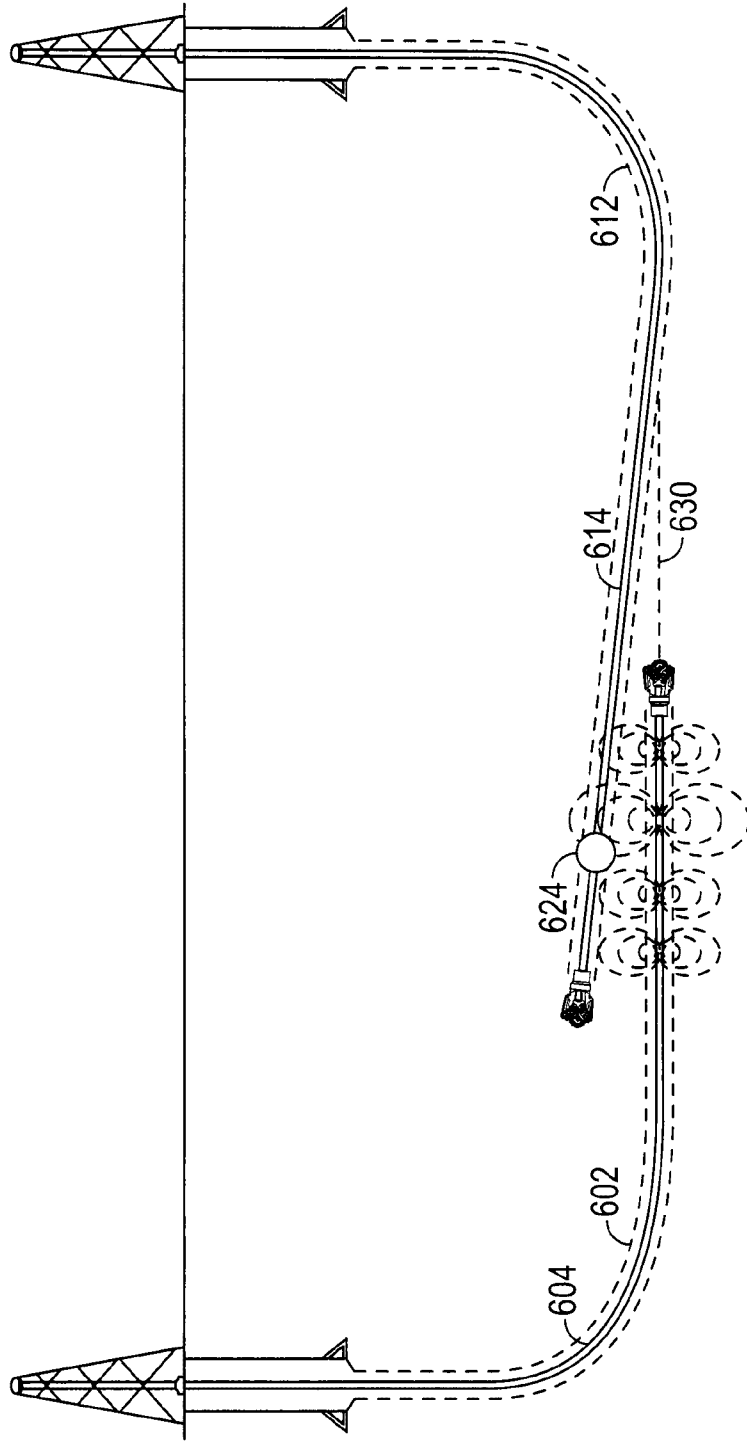

FIG. 7

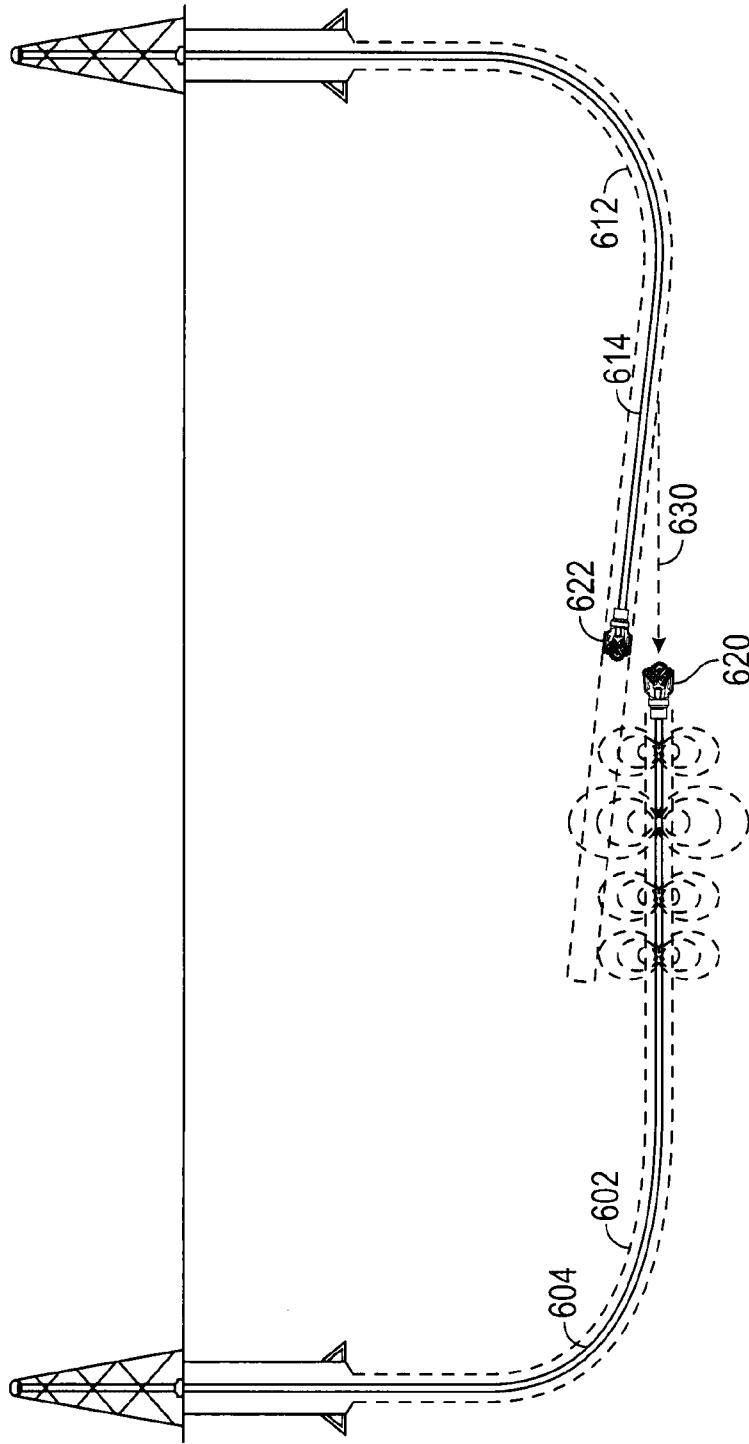

FIG. 8



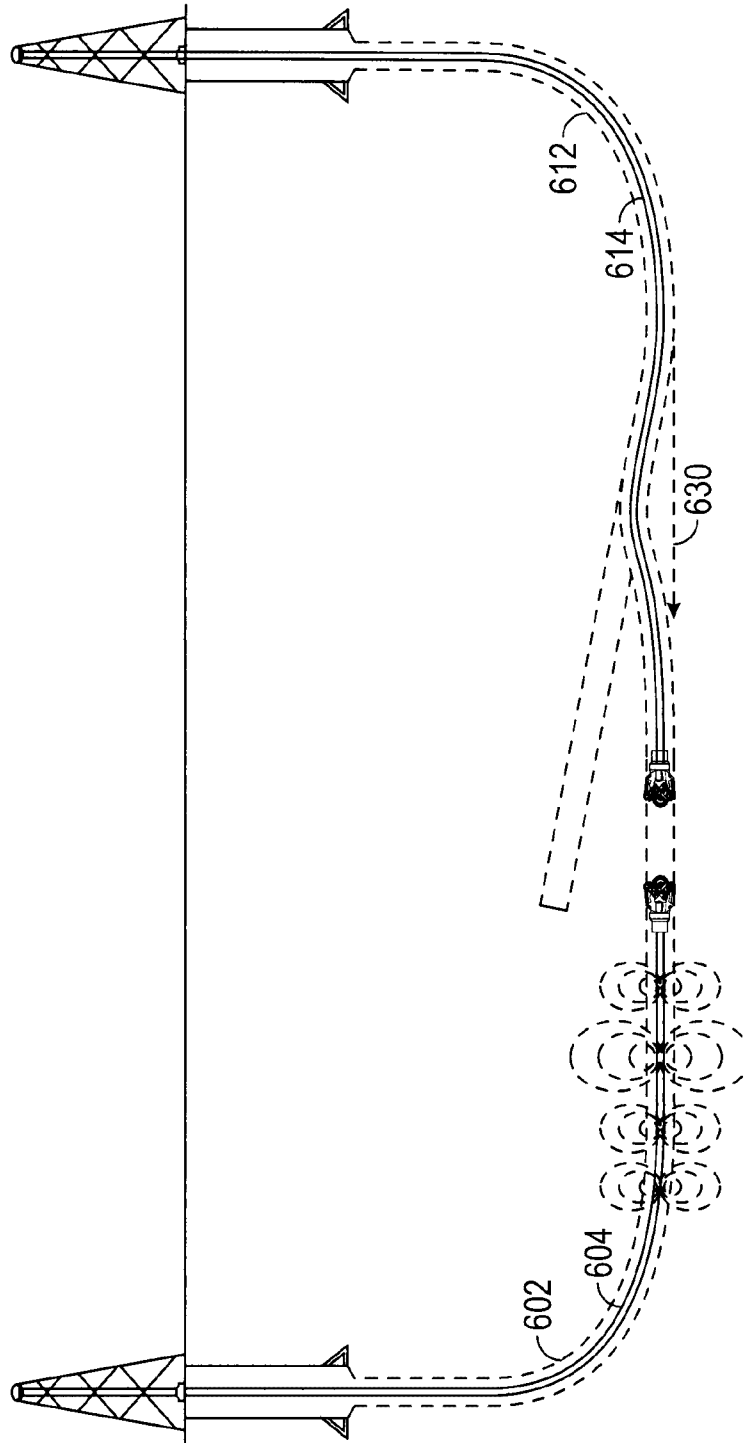

FIG. 9

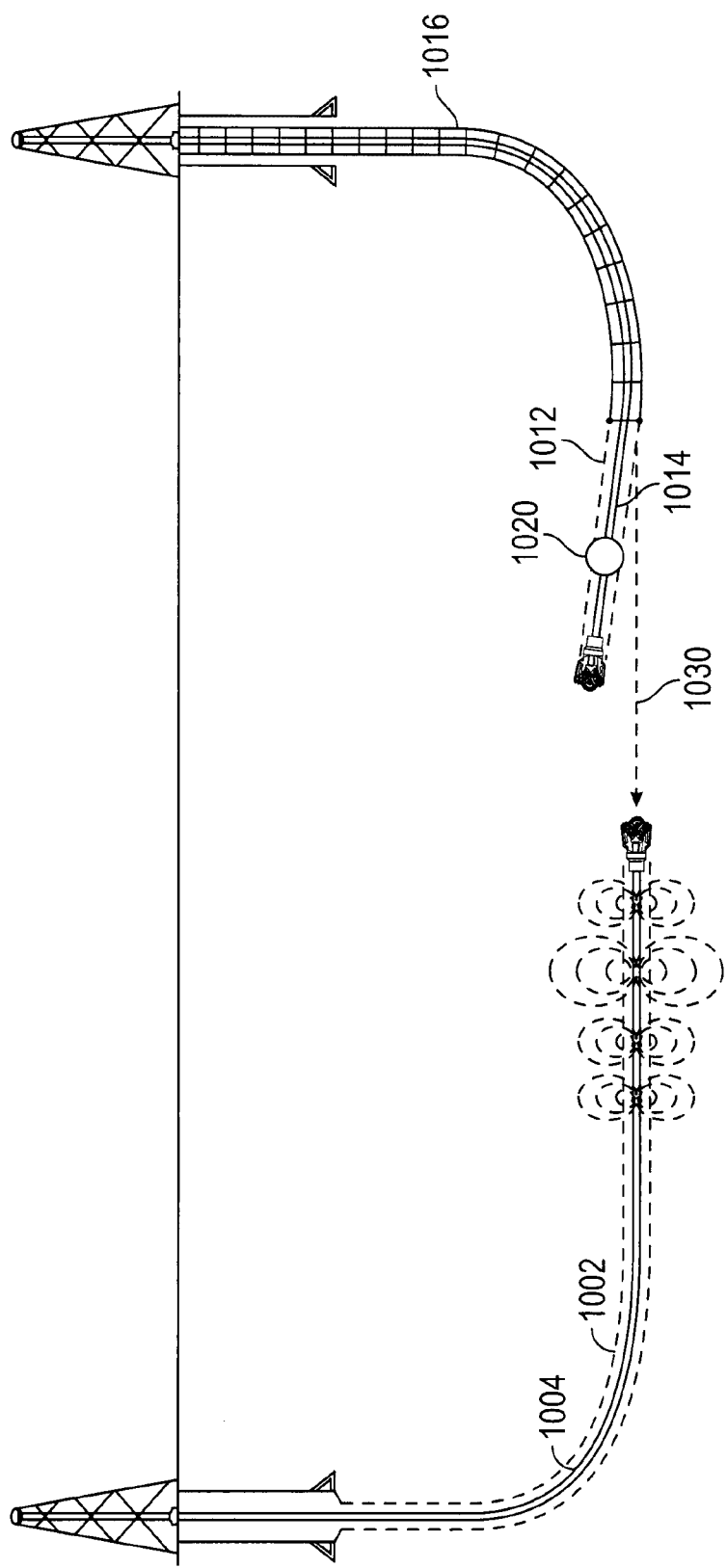

FIG. 10

11/12

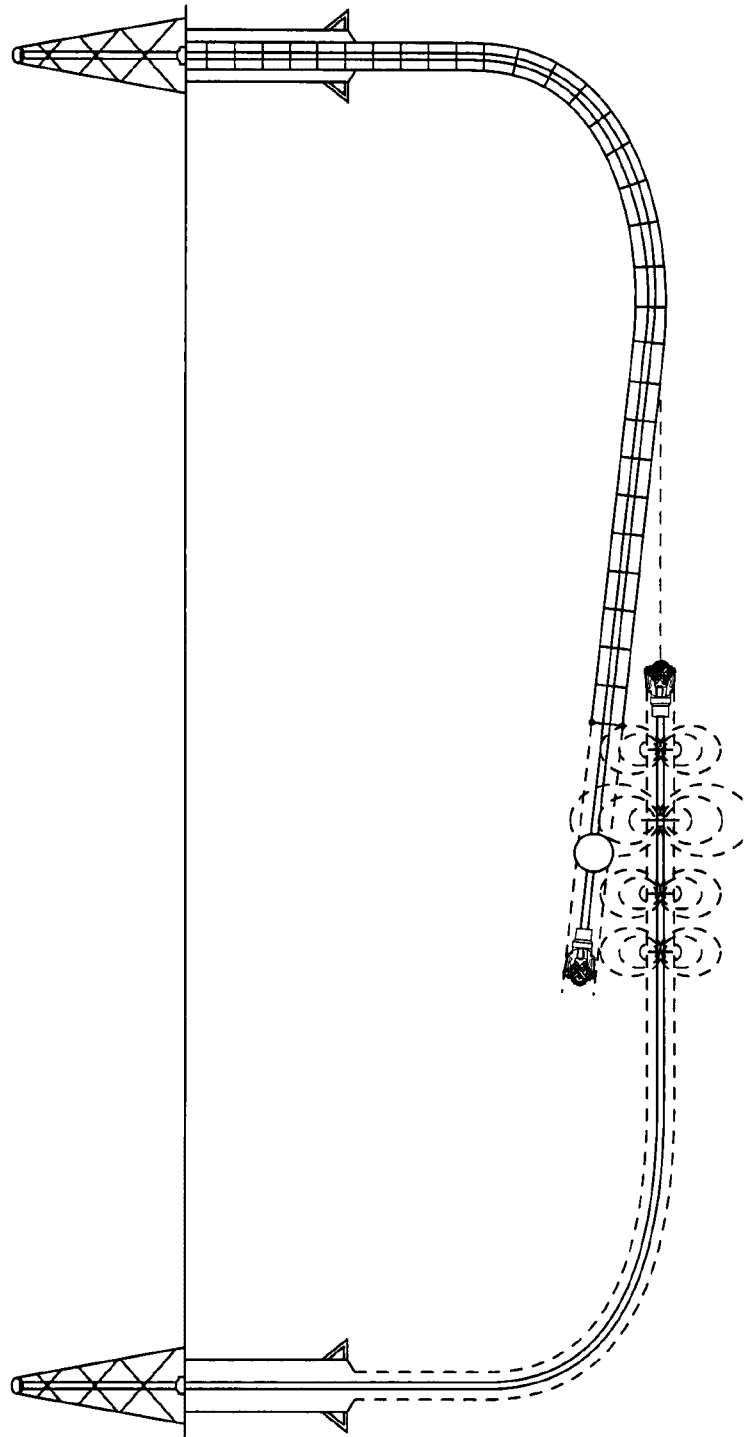

FIG. 11

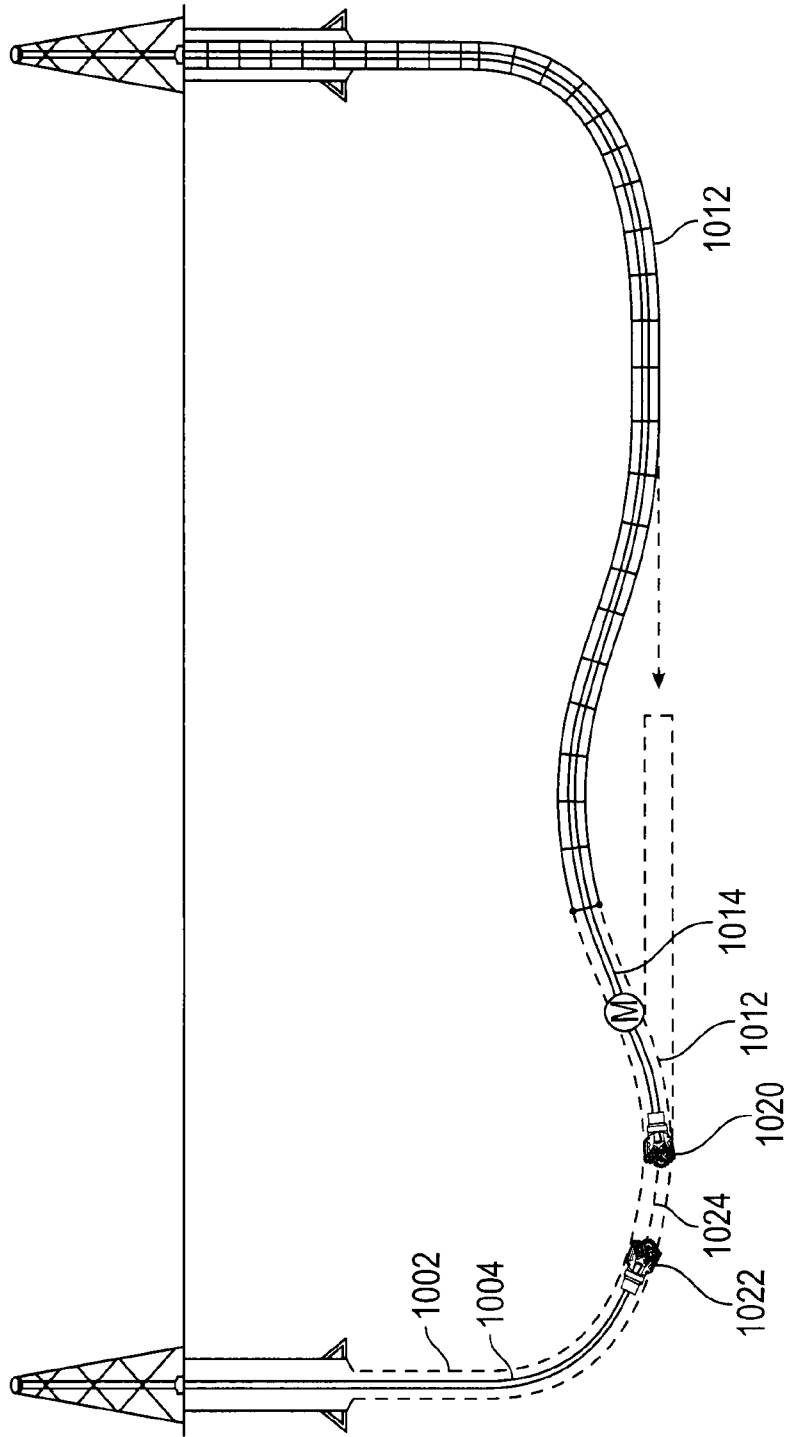

FIG. 12

