

(19)  
(12)

(KR)  
(Y1)

(51) 。 Int. Cl.7  
F41H 1/02

(45)  
(11)  
(24)

2004 08 05  
20-0358074  
2004 07 27

(21) 20-2004-0007494 ( )  
(22) 2004 03 18  
(62) 10-2004-0018225  
: 2004 03 18

2004 03 18

(73) 159 4

(72) 159 5

(74)

:

(54)

가 가 , ,  
가 (11) , 가 (10) ;  
가 (22) , 가 (21) 가 (20) ;  
(31) , 가 (30)

5

, , , , ,

1

2

3

가

4

5

6

< >

10 : 20 : (FLEX.ARAMID FELT)

21 : 22 :

30 : 11,21 :

가 , 가  
r) (Plate) (Garment) , (Panel amp; Panel Cove

NIJ 0101.04 가 (NIJ)

Y POLYETHYLENE) (PARA - ARAMID) , (HIGH DENSIT

ARON DEIJIN ) (KEVLAR: ) (TWARON:TW  
(DYNEEMA:DSM ) (SPECTRA:HONEY WELL )가

NIJ A , (35~36 )

가

(Deformation) 가 , (NIJ 44mm )

가가

1a  
(1)

1b

(1) (2)

가

(1)  
(2)

(2)

1c 1d

(1)

(2)

2

(3)

(2)  
(3)

가

(2)

(1)  
가

(2)

(1)

(2)

(2)

(1)

(2)

(1)

가

(2)

가

,가

(1)

150

(2)

(1)

(2)

가

(1)

가

3

(2)

(2)

가

(2)

(4)

3

(4)

(4)

(2)

(2)  
ITY POLYETHYLENE)  
가

(PARA-ARAMID)

가  
가

(HIGH DENS

[ 1 ]

[ 1 ]

(g/m <sup>2</sup> )	1.44	0.97

	427 ~ 482	140 ~ 150
(kg/tex)	237	320
	<	

4 (Unidirectional Shield) (1) (2) , 가 (5)

, 가 (5) 가

, (5) 가 . ,

(2) 가 3 가 (4) , (5)

, )가 가 HYBRIDS(

, 가 (2) (5) (2)

, (2) (1) 가 150 , (34~36 )

가 가 가

, 가 가

, ; 가 가 가 ,

가 ; 가 ,

, 5 6 .

5 (20) (10) (30) ,

(10) (11) 12 , (20) 6 가

(22) , 가

(30) (31) 11 24 (21)

(10) (30) 가  
 , 150 (10) (30) (Deformation) (20)

[ ]

H.P.WHITE LABORATORY,INC.) NIJ( ) ( )  
 [ 2]  
 < 1> (11 ) (6 )- (1 )- (10 )- (5 ) (2 )- (10 )- (1 )- (1 )- (1 )- (1 )-  
 3> (1 )- (1 )- (1 )- (1 )- (1 )- (1 )- (1 )- (1 )- (1 )- (1 )-  
 < 5> (9 ) (1 )- (1 )- (1 )- (1 )- (1 )- (1 )- (1 )- (1 )- (1 )- (1 )-  
 < 2> (1 )- (1 )- (1 )- (1 )- (1 )- (1 )- (1 )- (1 )- (1 )- (1 )-  
 < 4> (14 )- (4 ) (1 )- (1 )- (1 )- (1 )- (1 )- (1 )- (1 )- (1 )-  
 < 6> (9 ) (1 )- (1 )- (1 )- (1 )- (1 )- (1 )- (1 )- (1 )- (1 )- (1 )-

[ 2]

Test Sample			Ballistic Threat			Result
No	Weight (1bs)	Plies	Obliquity (degrees)	Caliber (a)	Shot	Penetration
1	3.64	24	0	.44Mag	4	0
			30	.44Mag	2	0
2	3.72	22	0	.44Mag	4	1
			30	.44Mag	2	0
3	3.74	24	0	.44Mag	4	1
			30	.44Mag	2	0
4	3.63	27	0	.44Mag	4	0
			30	.44Mag	2	0
5	3.68	22	0	.44Mag	4	1
			30	.44Mag	2	0
6	3.70	22	0	.44Mag	4	1
			30	.44Mag	2	0

(a) NIJ-STD-1010.04, Level velocity: 1400~1460 fps  
 (b) Shots in excess of two UNFAIR. Data for FAIR shots only

100% 가 < 1> < 4> 가 0 30

14 , < 4> 가 < 1> 가  
 , < 1> 가 가 3 (Level )  
 (11) 11 (20)  
 (31) 10 (20)  
 가 24  
 가  
 [ ]  
 NIJ-STANDARD-0101.04  
 [ 3]

[ 3]

NIJ			DSM ( )		TWARON,DUPONT ( )	
LEVEL A	5,245g/m <sup>2</sup>	24	5,300g/m <sup>2</sup>	34	6,800g/m <sup>2</sup>	34
LEVEL	4,445g/m <sup>2</sup>	20	4,500g/m <sup>2</sup>	29	5,800g/m <sup>2</sup>	29
LEVEL A	3,645g/m <sup>2</sup>	16	3,720g/m <sup>2</sup>	24	4,800g/m <sup>2</sup>	24

가 NIJ 가

30 (AREAL DENSITY:g/m<sup>2</sup>) 가

, 가 가

(57)

1. 가 (11)  
 (10) ;  
 가 가 (22) , 가 (21)  
 (20) ;  
 (31) , 가  
 (30)

2.

1

(20)  
(11) 11

(30)

22~24

(31) 10

(10)

3.

1a

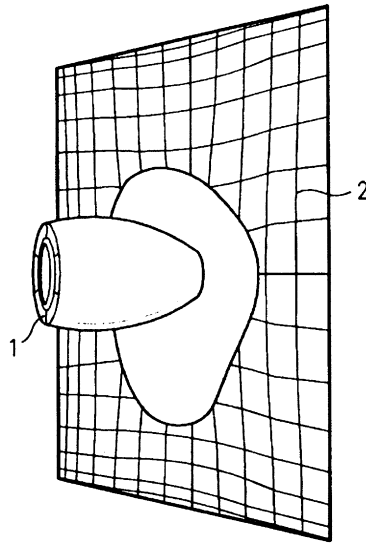

1b

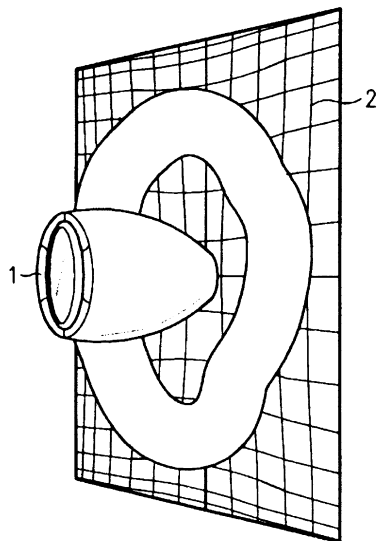

1c

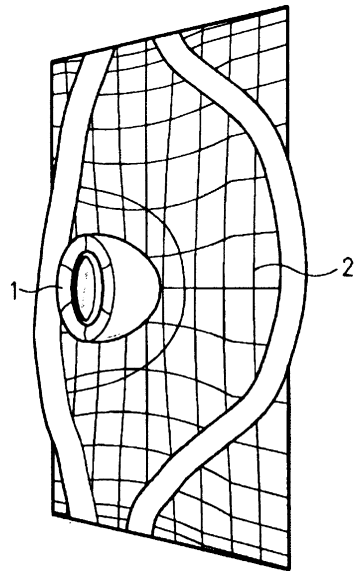

1d

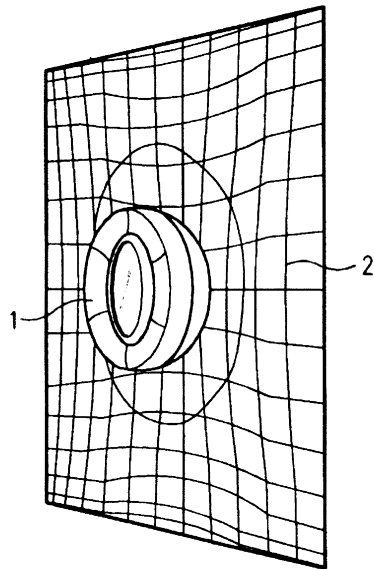

2

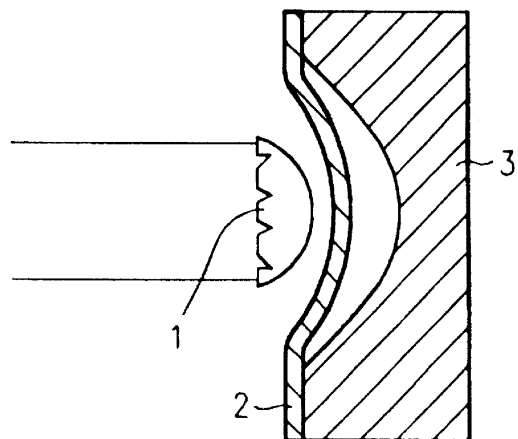



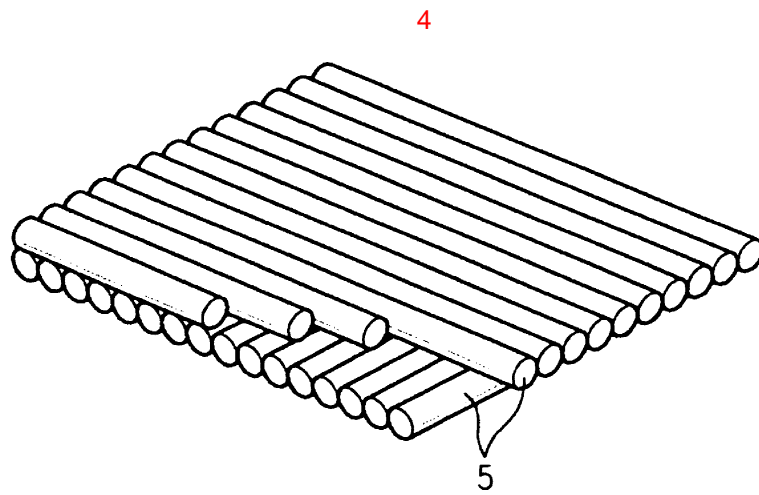
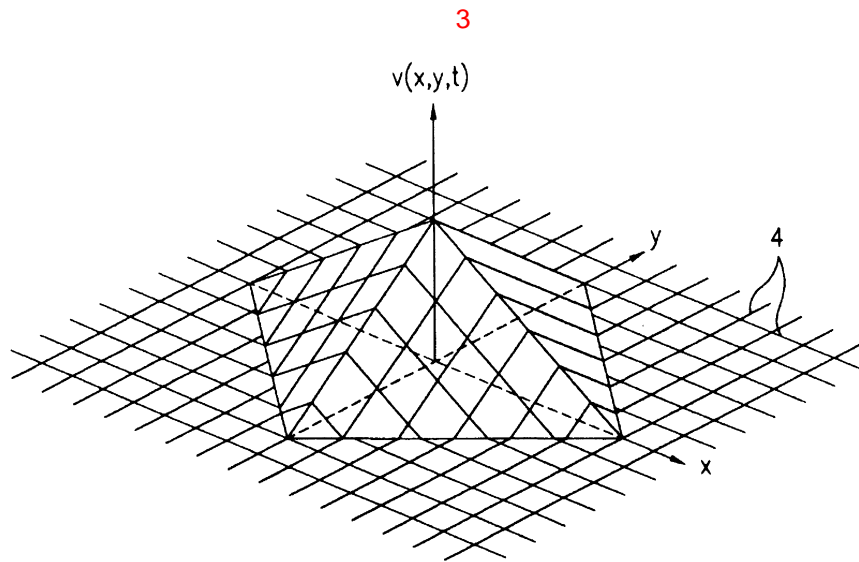

5

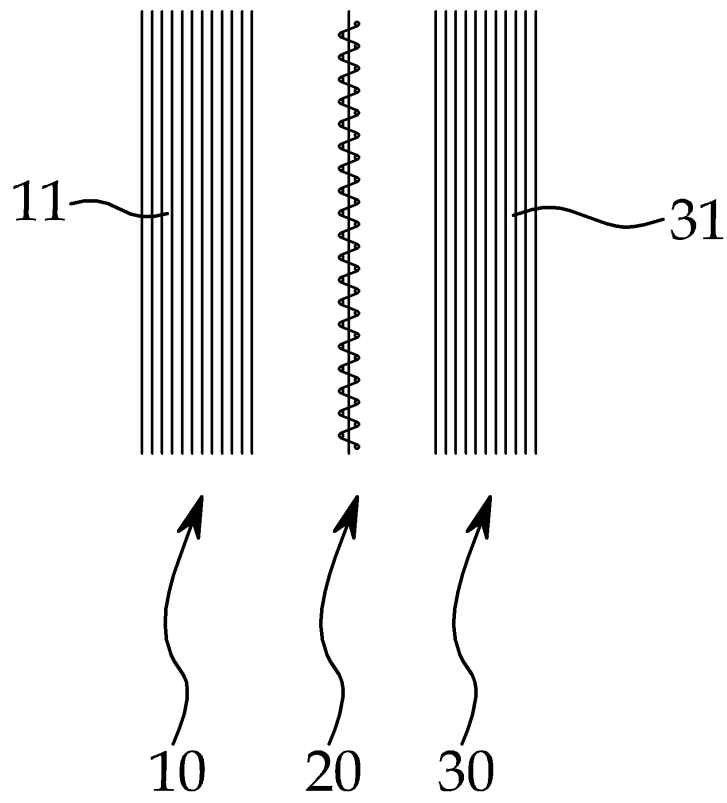

6

