



US 20030062059A1

(19) **United States**

(12) **Patent Application Publication**
Hildreth

(10) **Pub. No.: US 2003/0062059 A1**

(43) **Pub. Date: Apr. 3, 2003**

(54) **HAIR TREATMENT DEVICE**

Publication Classification

(76) Inventor: **Michael S. Hildreth**, Savannah, GA
(US)

(51) **Int. Cl.⁷ A45D 7/04**

(52) **U.S. Cl. 132/243**

Correspondence Address:
Paul E. Knowlton, Esq.
KILPATRICK STOCKTON LLP
Suite 2800
1100 Peachtree Street
Atlanta, GA 30309-4530 (US)

(57) **ABSTRACT**

A hair treatment device and method, for use in changing the appearance of hair. The device comprises a compressible hair roller including a roller body and a base including ends with cradles which receives the roller body. The combination of the roller body and base, together with the respective construction, results in a more natural looking and feeling "perm".

(21) Appl. No.: **09/966,324**

(22) Filed: **Sep. 28, 2001**

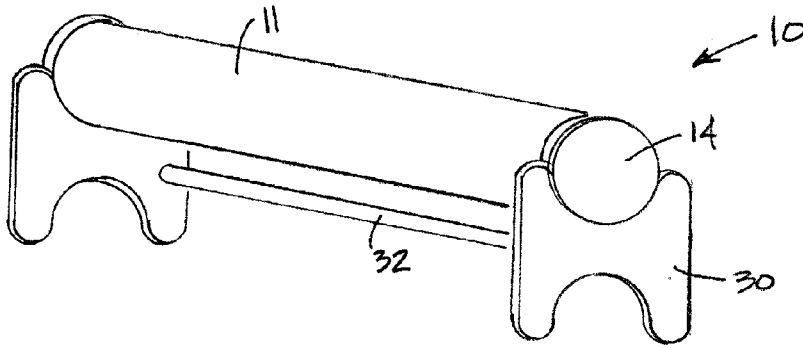

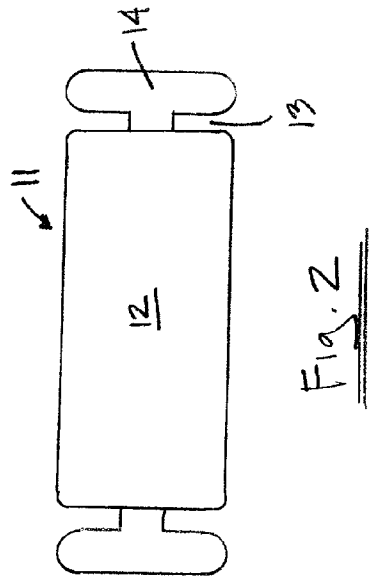
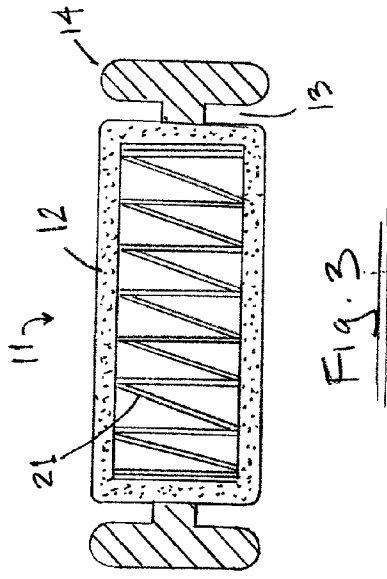
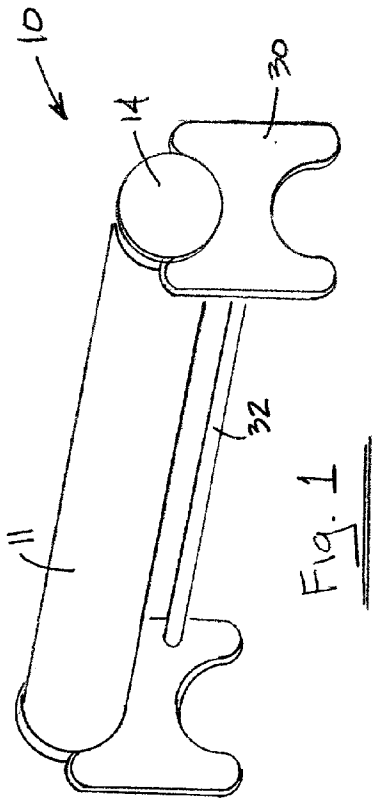

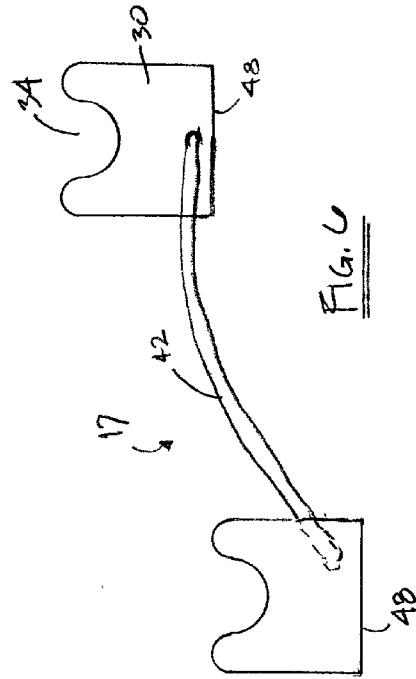
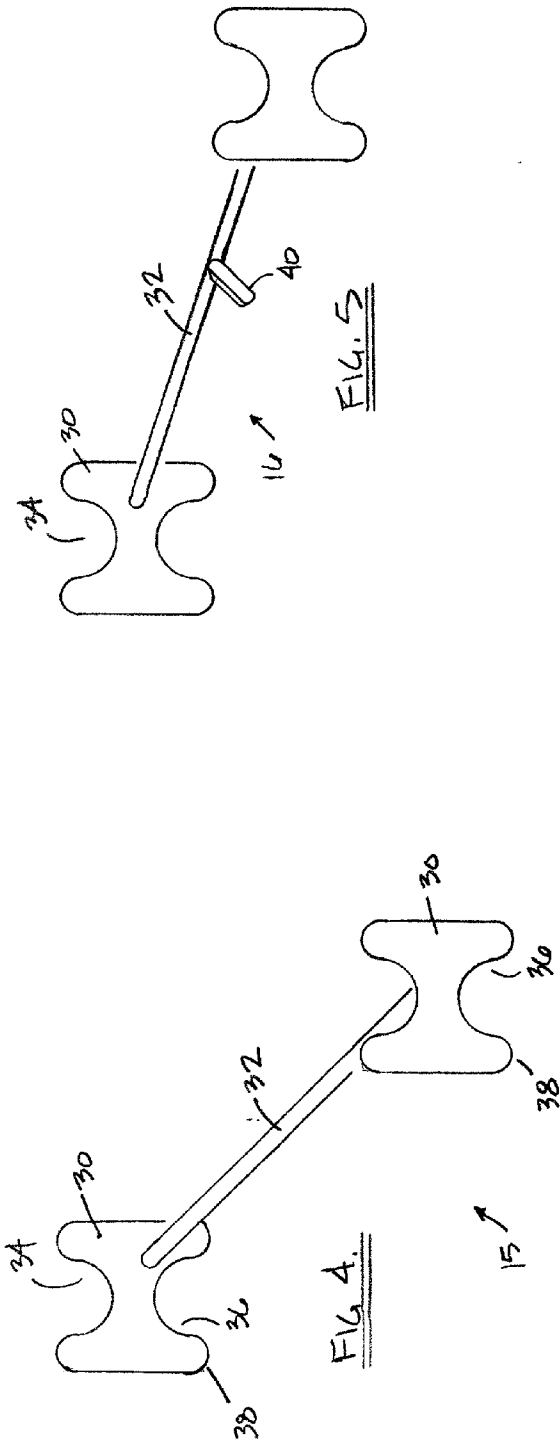

HAIR TREATMENT DEVICE

FIELD OF THE INVENTION

[0001] The present invention is directed to hair treatment devices, and more particularly pertains to a new and improved device for changing the appearance of an individual's scalp hair.

BACKGROUND

[0002] Individuals are known to change the appearance of their hair. The most effective way to achieve a long-lasting change in the appearance of one's hair is through the application of a "permanent", also known as a "perm." A permanent is a hair treatment that produces a long-lasting hair wave or hair straightening by mechanical and/or chemical means.

[0003] Conventionally, when an individual is receiving a permanent, their hair is first sectioned and wrapped around individual cylindrical rollers. The individual roller, beginning at the unattached end of the hair, is wound up the entire length of a section of hair until the roller contacts the scalp. The wrapped hair is then secured by bands extending from one end of the roller to the other. To hold the roller in place, a small thin piece of plastic known as a pick is inserted between the scalp and the roller so that the roller tightly rests directly on the individual's scalp.

[0004] When chemicals are applied to the hair during the permanent process the hair swells and expands, pressing the hair tightly against the bands and directly onto the individual's scalp. This expansion causes tension on the roots which in turn causes that section of the hair close to the scalp to catch, split, and break, creating undesirable frizzing and kinking of the hair. Moreover, the pick itself sometimes damages the hair as well as causes discomfort to the wearer. Finally, because the roller is pressed tightly against the scalp, it is almost impossible to completely treat the full length of the wrapped hair. Consequently, the desired effect does not begin from the hair roots but follows a flat impression where the rod was previously positioned.

[0005] There are a number of disadvantages in using presently available rollers or similar hair treatment devices. One example of such a hair treatment device is taught by U.S. Pat. No. 2,287,335, which issued to Yven on Jun. 23, 1942. This patent discloses a protector unit incorporating a base and separable hair engaging member constructed of foldable materials. There the base and engaging members are "built" for each use and, preferably disposed of immediately upon each use.

[0006] U.S. Pat. No. 2,603,225, which issued to Buchanan on Jul. 15, 1952, discloses a hair treatment device constructed as a central curling rod provided with a series of thin cylindrical shells. The shells are formed from semi-cylindrical halves made of material capable of heat conductivity. This allows the device to control the distribution of heat within each curling unit. Yet such curlers, involving the use of metal and heat conductive parts, absorb heat under a hair dryer and frequently result in severe discomfort to the wearer, even burning the scalp.

[0007] U.S. Pat. No. 2,722,222 which issued to Whaley on Nov. 1, 1955, discloses a hair treatment device that protects the scalp by a scalp protector-rod securing device. The

protector device is formed from several layers of insulator and water proof materials constructed so that hair can be threaded between the adjacent layers. In addition to the complicated scalp protector, the device requires a process wherein the hair is chemically treated before it is mechanically rolled.

[0008] U.S. Pat. No. 4,327,754, which issued to Hildreth on May 4, 1982, discloses a contoured comb or sectioning tool which is used to separate a section of hair to be rolled. The comb functions as a stand-off so that the roller does not contact the scalp. In order to utilize the sectioning comb as a stand-off for the rollers, it is necessary to have special rollers which are segmented and which bend to conform to the contour of the comb and lock to the comb.

[0009] U.S. Pat. No. 4,898,194, which issued to Einspahr on Feb. 6, 1990, discloses a hair waving device made of thin, flexible plastic. The use of spring clips, metal or otherwise, for securing the curler after rolling the hair creates a flat area on the curl which is sometimes difficult to cover up with certain hair styles.

[0010] While the above described references teach devices undoubtedly suited for their intended usage, none of those devices teach a hair treatment device that reduces or eliminates hair breakage at the scalp, provides a compressible roller, presents the roller from contacting the scalp, or eliminates the roller compression mark at the scalp. Additionally, none of the aforesaid devices prevent undesirable frizzing or kinking. Although the art is relatively crowded with respect to various types of hair treatment devices, there is a continuing unmet need for and interest in solving the problems remaining in the art.

SUMMARY OF THE INVENTION

[0011] The present invention relates to improvements in hair treatment devices. In particular, the present invention solves many of the known problems in the art by providing a compressible hair roller and a means for keeping the hair roller from contacting the wearer's scalp during the hair treatment process.

[0012] In a preferred embodiment of the present invention, the hair roller is tubular and notched at opposite ends, and a base implement is configured to correspond in size to the length and circumference of hair roller. The hair roller body is made of a material that is malleable so that, when heat is applied, either chemically or conductively by a heating means, the roller body gently expands thereby applying pressure to the hair. Alternatively, the outside of the roller is malleable while the inside of the roller may contain a mechanism that prevents the roller from collapsing on itself. Either embodiment of the hair roller is used with a base implement. The base has two ends and each end has a cradle for receiving a notch of the roller. The ends are connected to each other via a straight or curved support rod. In addition, the support rod can include a short support arm.

[0013] In practice, hair is sectioned and wrapped around the roller body in a conventional fashion, and then the hair roller is placed on the base implement. More specifically, the notches of the roller are set in the cradles of the base ends, respectively. A permanent treatment solution is next applied to the hair.

[0014] The present invention overcomes the problems which still exist in the prior art by providing a hair treatment

device comprising a hair roller including a compressible roller body, a first notch and a second notch; a base implement including a first end and a second end wherein both the first and second ends each include a cradle for receiving the notches; and, a support rod connecting the first end and the second end. Further, the present invention overcomes the problems that still exist in the prior art by providing a method of changing the appearance of one's hair by using a hair treatment device comprising a hair roller including a compressible roller body, a first notch and a second notch; a base implement including a first end and a second end wherein both first and second ends each include a cradle for receiving said notches; and, a support rod connecting the first end and the second end.

BRIEF DESCRIPTION OF THE DRAWINGS

[0015] FIG. 1 is a perspective view of a preferred embodiment of the present invention.

[0016] FIG. 2 is a side view of an embodiment of a hair roller of the present invention.

[0017] FIG. 3 is a cross-sectional view of another embodiment of a hair roller of the present invention.

[0018] FIG. 4 is a perspective view of an embodiment of a hair roller base of the present invention.

[0019] FIG. 5 is a perspective view of another embodiment of a hair roller base of the present invention.

[0020] FIG. 6 is a perspective view of another embodiment of a hair roller base of the present invention.

DETAILED DESCRIPTION

[0021] Referring now in more detail to the drawings, wherein like numerals refer to like parts throughout the various views, FIG. 1 is a perspective view of a preferred embodiment of the present invention 10.

[0022] FIG. 2 depicts a hair roller 11 according to one embodiment of the present invention. The hair roller 11 includes a tubular roller body 12, around which hair is wrapped. It will be understood by those skilled in the art that the roller body 12 is not limited to a generally circular tubular cross-section, but may be, by way of example and not limitation, square, hexagonal, or octagonal cross-section, the cross-section being merely a design choice. The hair roller 11 also includes notches 13 formed by axial portions of reduced diameter at ends of the roller body 11 and located between the body and the ends 14. The exterior circumference of the hair roller 11 may vary, the actual dimension being merely a design choice. The base implement 15, 16, 17 (best shown in FIG. 4, FIG. 5, and FIG. 6, respectively) is configured to correspond in size to the length and circumference of hair roller 11.

[0023] In a preferred embodiment, the roller body 12 is made of a material that is malleable so that, when heat is applied, either chemically or conductively by a heating means, the roller body 12 gently expands, thereby applying pressure to the hair. At the same time, the hair shaft is kept under tension by allowing the hair being permed to settle into the compressible roller body 12. This may be accomplished in several ways. By way of example and not limitation, a compressible body 12 may be an open cell plastic or a hollow core roller 11. The material for the hair roller 11

may be selected such that when heat is applied, the hair roller body 12 will expand. The roller body 12 is preferably made from an open celled, lightweight, heat insulating material so that the air inside, when heated, causes expansion. Additionally, the materials used for the axial portion that defines the notches 13 and ends 14 may be the same or different than hair roller body 12.

[0024] In an alternative embodiment of the hair roller 11, if the interior of the roller 11 is hollow, the interior of the roller body 12 may contain a mechanism that prevents the roller body 12 from collapsing on itself. For example, as seen in FIG. 3, the hair roller body 12 could contain a coil 21 or similar means designed to maintain the shape of the roller body. The coil 21 could be made in any shape and out of any material that allows the roller body to press outwardly or compress in response to heat and tension.

[0025] Either embodiment of the hair roller 11 is used with a base implement 15, 16, 17 as best shown in FIG. 4, FIG. 5, and FIG. 6, respectively. The base implement prevents the roller body 11 from being pressed against the scalp during application of the permanent, that is, during application and removal of the chemical solutions to the hair during the process of applying a perm, such solutions and methods of applying and removing are well known by those skilled in the art. For the purpose of the present discussion, only base 15 is referenced but that which is taught with regard to base 15 is applicable to bases 16 and 17. The base 15, as shown in FIG. 4 has two ends 30. Each end 30 has a cradle 34 for receiving a notch 13 of the roller 11. At the edge opposite the cradle 34, the end 30 may have a cut out shoulder 36. The cut out shoulder 36 reduces the surface area of the ends 30, thereby reducing contact with the scalp. In this embodiment, the base 15 is supported by feet 38 which contact the scalp. Yet the ends 30 do not require a shoulder 36, as illustrated by the flat bottomed edge 48 best shown in FIG. 6.

[0026] As shown in FIG. 1, FIG. 4, and FIG. 5, the ends 30 are connected to each other via a straight support rod 32. The straight support rod allows the hair to be lifted from the scalp and fully treated with a permanent solution. Because of the curved shape of an individual's head, the hair is treated between $\frac{1}{8}$ and 1 inch from the root. Being able to fully treat the entire length of the hair, the hair appears "lifted" from the scalp, giving the hair more overall body and a better overall effect.

[0027] In the alternative, as best shown in FIG. 6, the support rod 42 may be curved or arched. The curved support rod contours the natural shape on an individual's scalp. Thus the hair gets treated more evenly, about $\frac{1}{8}$ inch from the root. After the treatment, the hair appears to be naturally curly because the curls all begin evenly close to the root. The support rod 32 or support rod 42 may be placed along various edges of the ends. Another option is to place the support rod 32 or support rod 42 in the middle of the ends, as represented by support rod 32 in FIG. 5. The position of the rod is chosen to result in as little contact with the roller body 12 as possible. In addition, the support rod 32 or support rod 42 can have a short support arm 40, as seen in FIG. 6, to hold the roller body 12 from resting on the scalp.

[0028] In practice, hair is sectioned and wrapped around the roller body 12 in a conventional fashion. Then the hair roller 11 is placed on the base implement 15. More specifically, the notches 13 are set in the cradle 34 of the base ends

30, as best shown in **FIG. 1**. A permanent treatment solution is next applied to the hair. Because the hair roller **11** sits above the scalp, all portions of the hair may be evenly treated with the permanent solution. When treated with the permanent solution, the hair swells and expands. Upon application of a neutralizer the hair contracts, opposed by the roller body. Because the roller body is made of a malleable, lightweight material, the hair is not tightened around a conventional rigid roller or forced against bands and/or the scalp. Thus, the hair is not stressed while contracting. Accordingly, hair breakage and root damage do not occur, resulting in a more natural looking perm. The treatment of the hair is then continued and concluded according to conventional practice.

[**0029**] The foregoing is illustrative of the principles of the present invention. Obvious modifications and changes will readily occur to those skilled in the art, thus it is not desired to limit the present invention to the exact construction and operation shown and described, and accordingly, all suitable modifications and equivalents may be resorted to, falling within the scope of the claims.

I claim:

1. A hair treatment device comprising:
 - a hair roller including a compressible roller body, a first notch and a second notch;
 - a base implement including a first end and a second end wherein both said first and second ends each include a cradle for receiving said notches; and,
 - a support rod connecting said first end and said second end.
2. The hair roller of claim 1, wherein said roller body is made of a lightweight, heat insulating material.
3. The hair roller of claim 1, wherein the inside of said roller body contains a supporting structure.

4. The base implement of claim 1, wherein said first end and said second end each include a cut-out shoulder.

5. The base implement of claim 1, wherein said support rod includes a support arm.

6. A base implement comprising:

a first end and a second end, wherein both said first and second ends each include a cradle; and,

a support rod connecting said first end and said second end.

7. The base implement of claim 6, wherein said first end and said second end each include a cut-out shoulder.

8. The base implement of claim 6, wherein said support rod includes a support arm.

9. A method of changing the appearance of one's hair comprising:

wrapping a tress of hair around a compressible roller body of a hair roller, wherein said hair roller includes a first notch and a second notch;

resting a base implement on a wearer's scalp, wherein said base implement includes a first end and a second end wherein both first and second ends each include a first and second cradle, respectively;

engaging said hair roller and said base implement by inserting said first and second notch into said first and second cradle, respectively;

applying solutions to the hair; and,

removing said tress of hair from said hair roller.

10. The method of claim 9 wherein heat is applied to said tress of hair.

11. The method of claim 10 wherein said solutions are removed from said hair.

* * * * *