

(43) Date of A Publication 17.01.2001

(21) Application No 0022385.9

(22) Date of Filing 08.07.1999

Date Lodged 13.09.2000

(30) Priority Data

(31) 9814749 (32) 08.07.1998 (33) GB

(62) Divided from Application No 9915973.3 under Section 15(4) of the Patents Act 1977

(71) Applicant(s)

**BTR Industries Limited**  
**(Incorporated in the United Kingdom)**  
**Invensys Plc, Carlisle Place, LONDON, SW1P 1BX,**  
**United Kingdom**

(72) Inventor(s)

**James Matthew Whelan**

(74) Agent and/or Address for Service

**J R Badger**  
**P O Box 8433, Invensys Intellectual Property,**  
**REDDITCH, B98 0DW, United Kingdom**

(51) INT CL<sup>7</sup>

**F16F 1/377 // F16F 1/40**

(52) UK CL (Edition S )

**F2S SCF S702 S705 S709**  
**U1S S1847**

(56) Documents Cited

**GB 1576398 A GB 1310671 A**

(58) Field of Search

UK CL (Edition R ) **F2S SCF**  
INT CL<sup>7</sup> **F16F 1/377 1/387 1/40 1/41 1/44 1/54**

(54) Abstract Title

**Elastomeric mounting for a vehicle suspension**

(57) An elastomeric mounting (10) for use in a vehicle suspension to accommodate compression and shear loading comprises a plurality of metal members (11,12) with the or each successive pair of metal members being spaced apart by and bonded to a layer (15) of elastomeric material, said metal members and elastomeric layer having a pair of substantially parallel and opposed edge regions (17), the material of each elastomeric layer when in an unstressed condition comprising a slot-like cavity (18) which extends substantially parallel with and spaced from said edge regions (17) of the layer, and the height of the slot-like cavity tapering progressively from an end region (19) of the or each elastomeric layer to a position (20) between longitudinal ends of the layer.

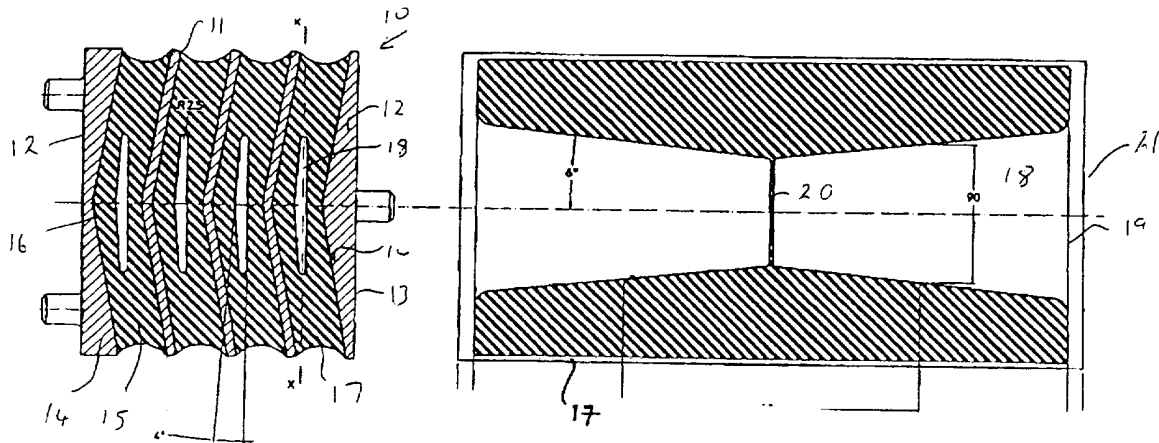

Figure 3

Figure 4

1/4

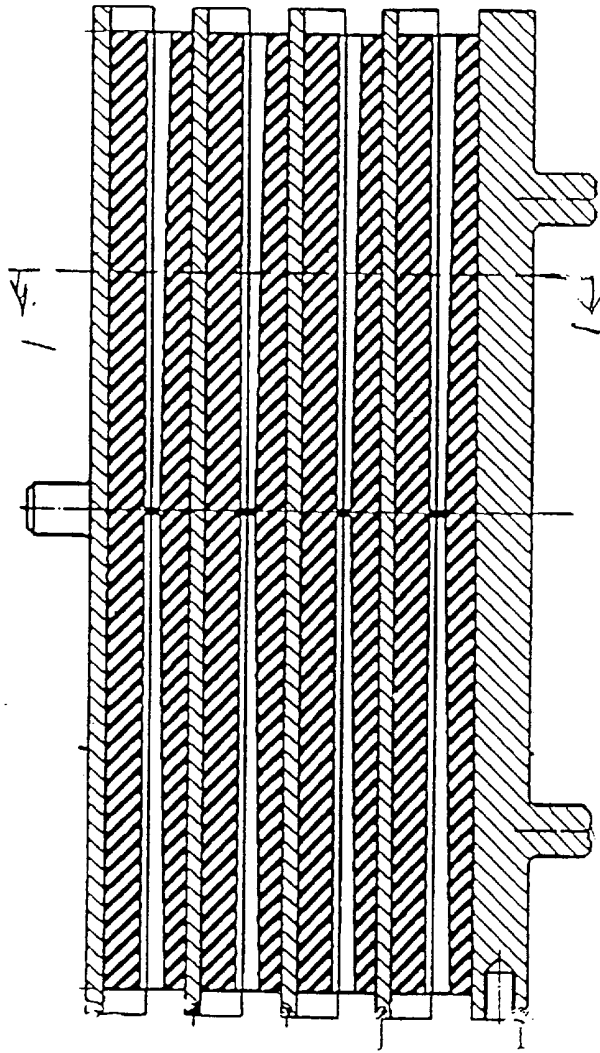

Figure 2

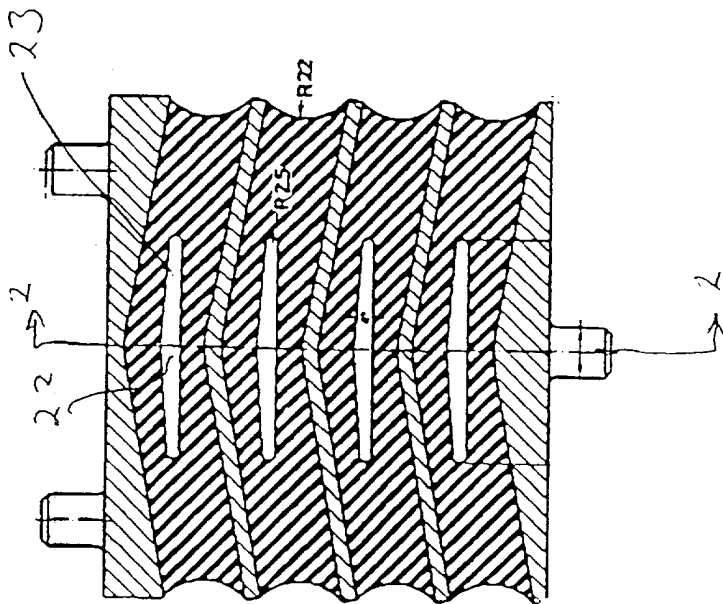

Figure 1

23

R22

R25

22

22

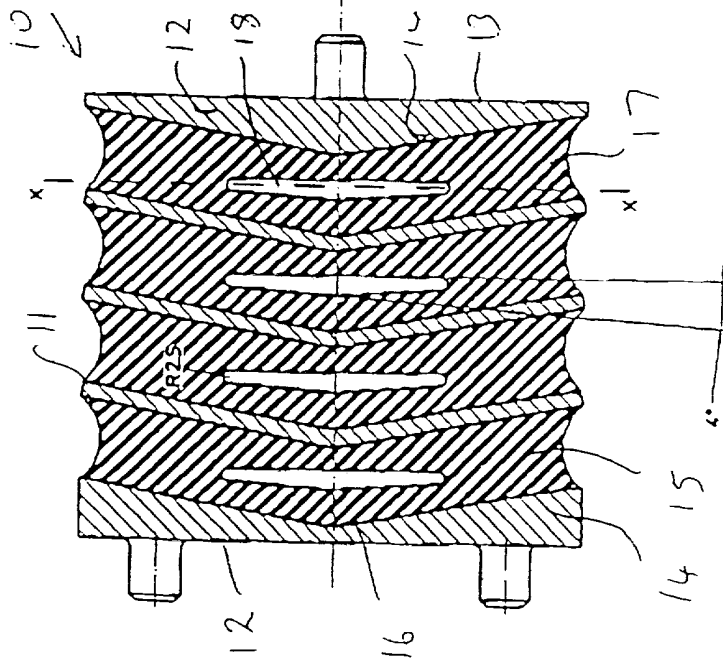

Figure 3

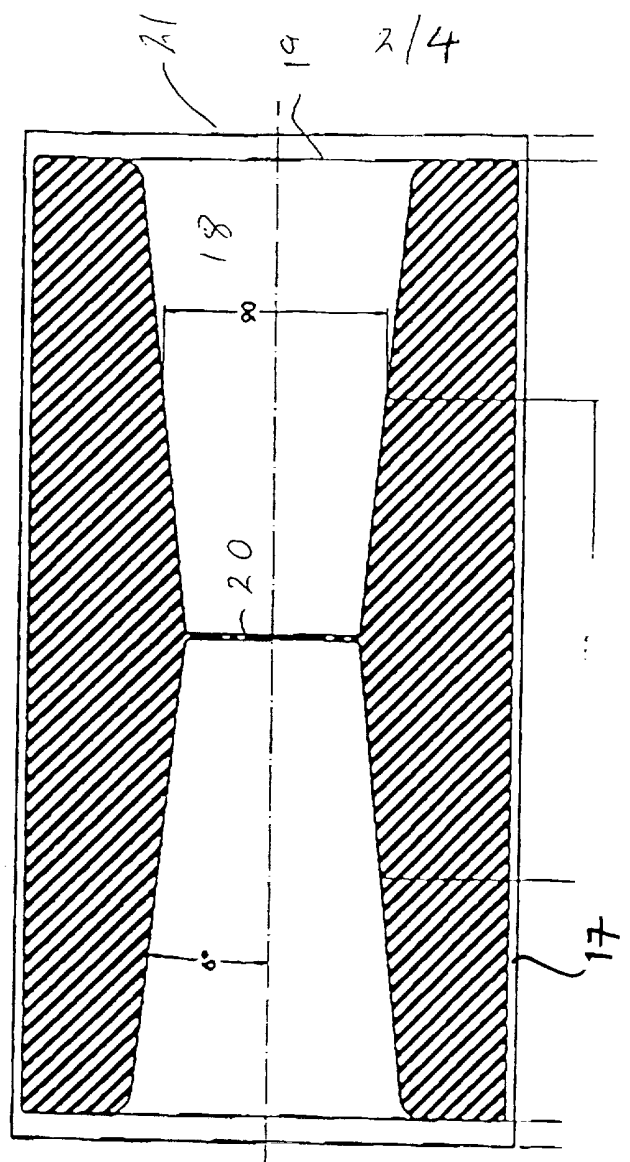
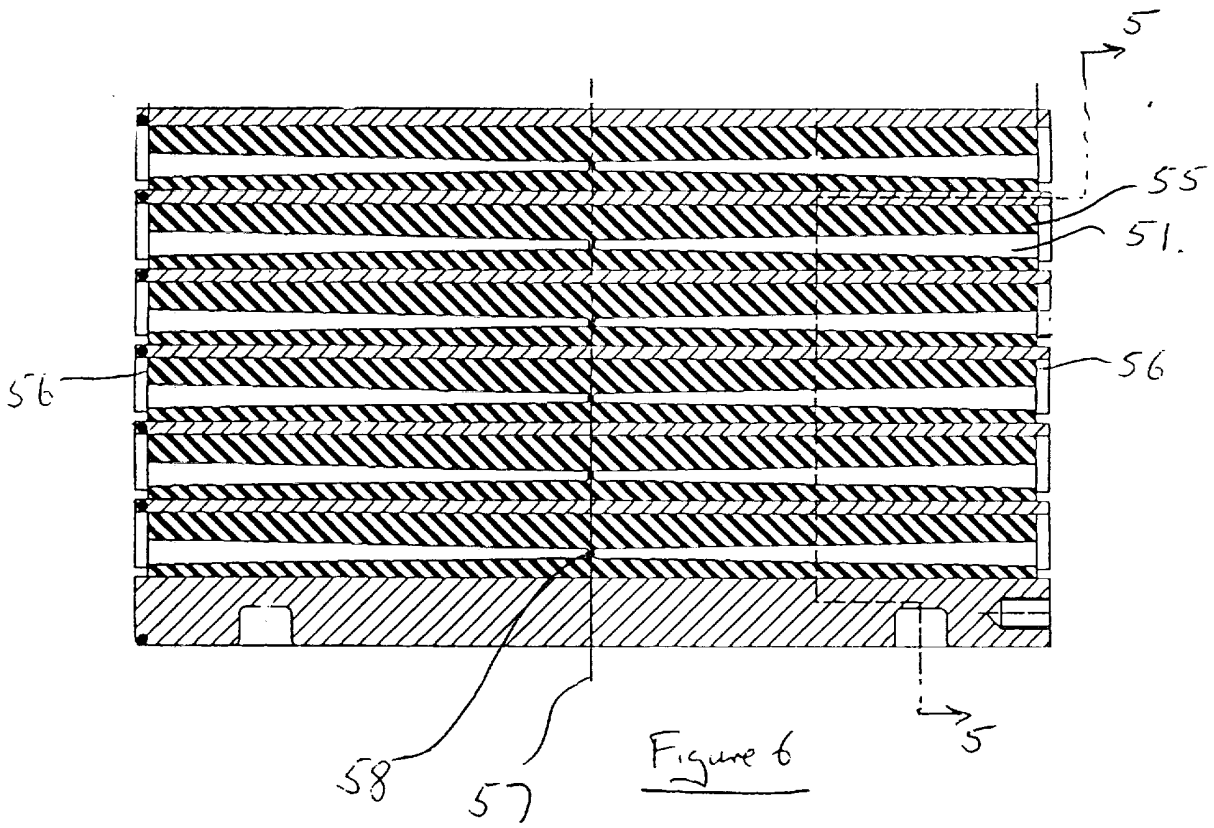
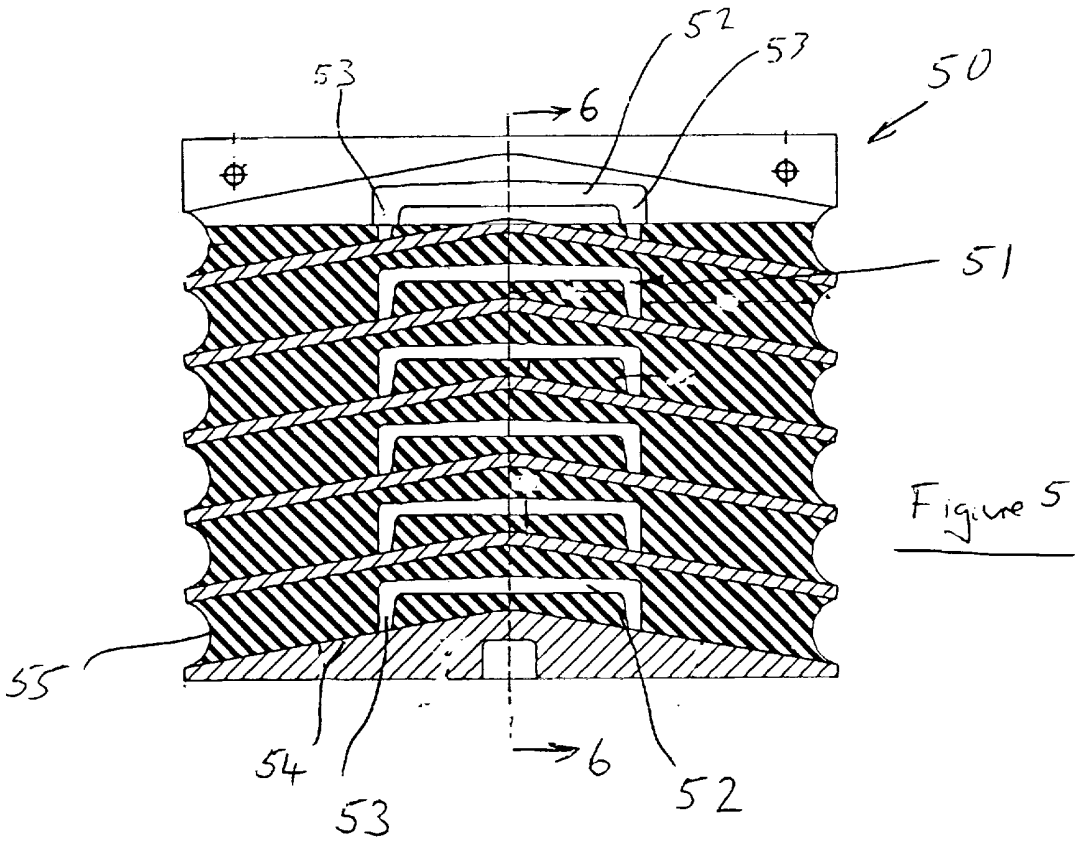

Figure 4

3/4



4/4

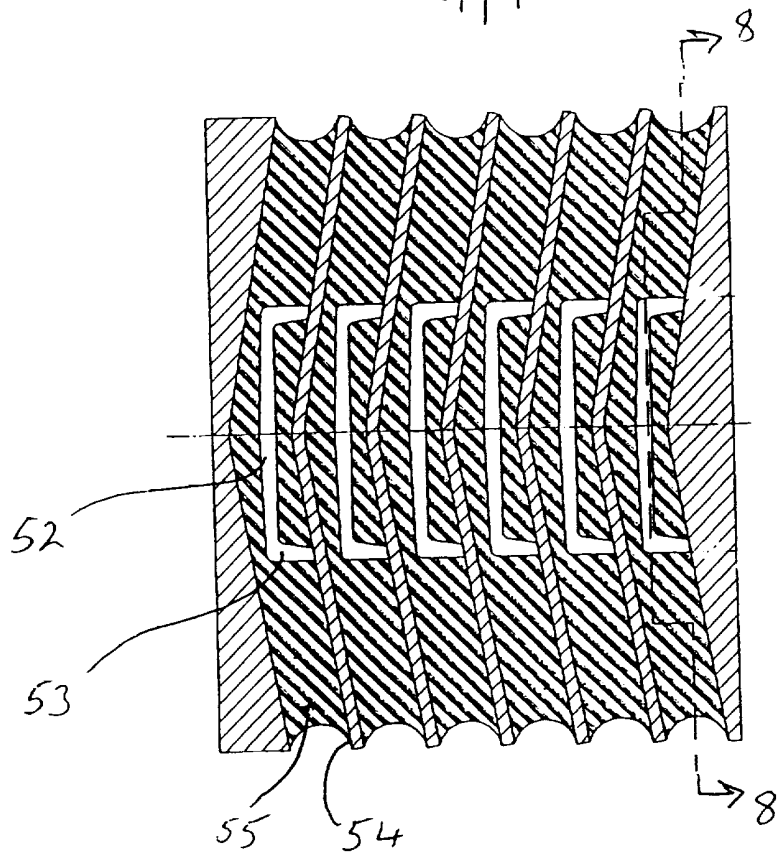

Figure 7

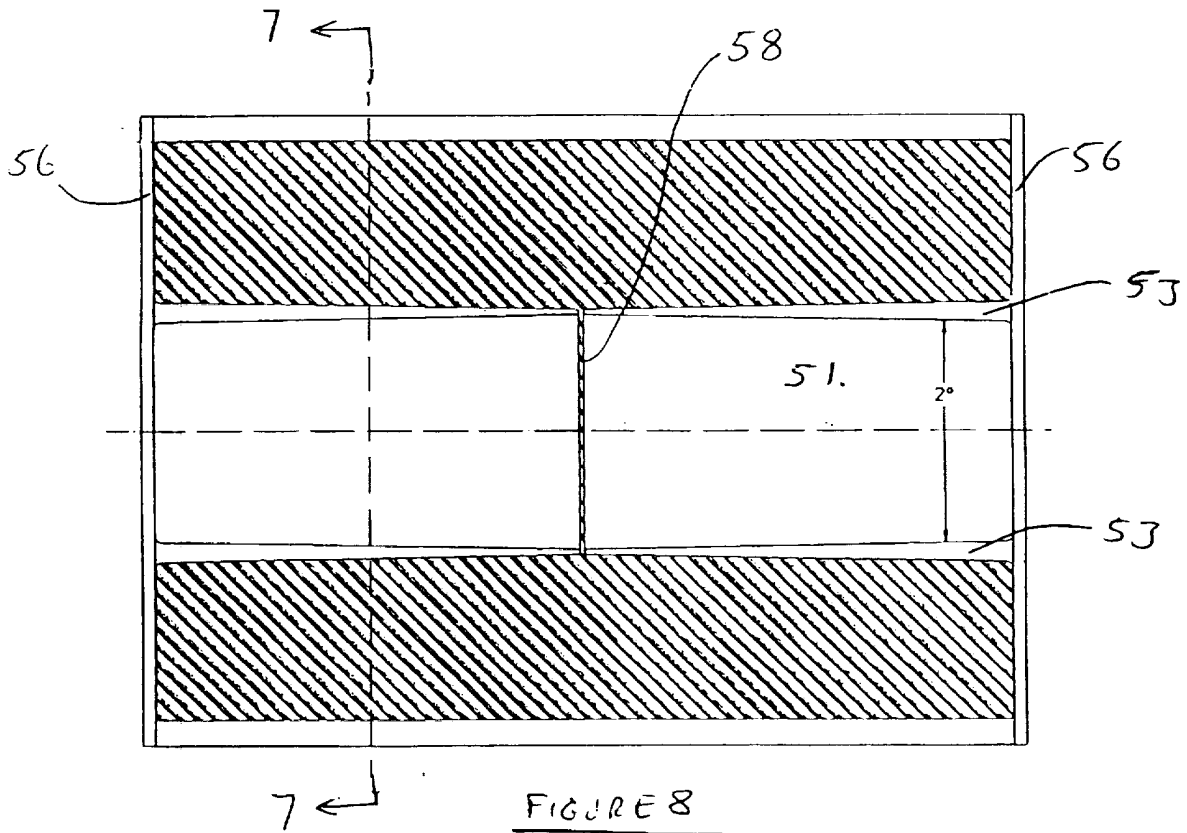

FIGURE 8

"ELASTOMERIC MOUNTING"

This invention relates to an elastomeric mounting and in particular, although not exclusively, to an elastomeric mounting suitable for use in a railway vehicle suspension and comprising an interleaved arrangement of metal plates and one or more layers of elastomeric material.

The invention relates also but not exclusively to an elastomeric mounting of the chevron type comprising an interleaved arrangement of angled metal plates arranged substantially superimposed and with the or each successive pair of plates spaced apart by a layer of elastomeric material.

In designing an elastomeric mounting suitable for use in a vehicle suspension it is necessary that the mounting can carry a large compressive load over a large range of deflection in a vertical direction.

When positioned as part of a secondary suspension between a vehicle bogie and vehicle body the mounting needs to provide adequate stiffness in a transverse direction, so that the vehicle body is maintained aligned adequately with the track, but needs to be relatively compliant in the direction of travel so as to accommodate movement of the bogie relative to the vehicle body and avoid high track forces when negotiating curved track.

Another consideration in designing an elastomeric mounting may be a requirement to provide a rising stiffness rate in a vertical direction, preferably a stiffness rate that increases progressively with increasing load.

According to one aspect of the present invention an elastomeric mounting for compression and shear loading comprises a plurality of metal members with the or each successive pair of metal members being spaced apart by and bonded to a layer of elastomeric material, said metal members and elastomeric layer having a pair of substantially parallel and opposed edge regions, the material of the or each elastomeric layer when in an unstressed condition comprising a slot-like cavity which extends substantially parallel with and spaced from said edge regions of the layer,

and the height of said slot-like cavity tapering progressively from an end region of the or each layer of elastomeric material to a central position mid-way between longitudinal ends of the layer.

The slot-like cavity preferably has a maximum thickness in the direction of vertical (normal) compression loading of the mounting which is less than one quarter, or preferably less than one sixth, of the maximum width of the slot as considered in a transverse direction between said opposed edge regions.

The reference to the slot-like cavity extending substantially parallel with said end regions of the layer of elastomeric material refers to the cavity extending in a lengthwise direction between the end regions.

Preferably also the width of the slot region tapers progressively from a maximum width at an end region to a minimum width at a central position mid-way between the end regions.

As considered in plan, the taper of the width of the slot preferably is in the range  $4^{\circ}$  to  $20^{\circ}$ . A suitable taper angle is  $6^{\circ} \pm 2^{\circ}$ . In each case the taper angle is measured relative to a central longitudinal axis, such that the relative angle between the sides of the slot is double the taper angle. Each slot may have a constant height as considered in any transverse plane, but more preferably is profiled so as to have a maximum height at the central position and minimum at transverse edge regions, being the regions of the slot closest to respective opposed edge regions of the associated elastomeric layer.

Preferably said metal members and elastomeric layer are of a substantially square or rectangular shape.

The metal members may be metal plates. The end metal members of a stack of pairs of metal members may be metal plates or metal castings. An intervening metal member also may be a casting.

The metal members may have flat surfaces to which the elastomeric layers are bonded. Alternatively the elastomeric mounting may be of the chevron type having V-shaped metal plates and/or castings and V-shaped elastomeric layers with the slot-like cavity extending in a lengthwise direction which is substantially parallel with the apex line of the V-shape.

End metal members of the chevron type mounting may have outer faces which are of a V-shape, to have two planar portions inclined relative to one.....

another, or flat outer faces.

Each slot may be positioned mid-way between a pair of successive metal members or it may be offset to lie closer to one of the metal members of the pair.

The slot shape may be defined substantially wholly by the elastomeric material, particularly as in the case of a slot which is positioned substantially mid-way between a pair of successive metal members. Alternatively a part of the slot shape may be defined in part by the elastomeric material and in part by one of the confronting surfaces of a pair of metal members. A slot may have a shape which, as considered in transverse cross-section, comprises a central section that lies between a pair of portions of elastomeric material and a pair of side sections which each extend from the central section to a position closer to a surface of one of metal members than the spacing of the central section from that surface of the metal member. Typically the side sections will extend towards the same metal member surface. The side sections may extend wholly to the surface of a metal member, the elastomeric material between a pair of plates then comprising in cross-section two, separate, sections, a main section which extends to each of said edge regions of the elastomeric layer and defines a void region therebetween, and an auxiliary section secured to one of the metal members to lie in said void region and define in part the shape of the slot-like cavity comprising said central and side sections. Whilst that transverse cross-sectional form may be present along the whole of the length of the cavity, the invention envisages that the sections may be connected to one another locally, and there may be no slot shape at a central position between, typically mid-way between, the ends of the elastomeric layer.

In a chevron type elastomeric mounting the central, transverse position of a slot may lie closer to the outer, obtuse angle surface of one of the V-shaped components than relative to the internal surface of the other metal member of the pair between which it is sandwiched. Outer transverse edge regions of a slot may lie closer to the internal surface of one of the metal members than the outer obtuse surface of the other of the pair of metal members between which the elastomeric layer is sandwiched. If the slot is of the aforementioned type



comprising, in transverse cross-section, a central section and a pair of side sections, the side sections preferably extend in a direction towards the obtuse surface of the pair of confronting obtuse and internal surfaces.

Preferably the slot is symmetrically disposed relative to the transverse width of the mounting.

The elastomeric material of the or each elastomeric layer preferably has a stiffness in the range 30 to 80 Shore A, more preferably between 45 and 65 Shore A.

According to a further aspect of the present invention a vehicle suspension system comprises an axle assembly secured to a vehicle body by at least one elastomeric mounting in accordance with the present invention.

The body and axle assembly may be secured to one another by a pair of said elastomeric mountings arranged spaced apart in the direction of the length of the rotational axis or axes of the vehicle wheels.

The axle assembly may be part of a vehicle bogie and the or each elastomeric mounting may be arranged to secure the bogie to a vehicle body. The or each mounting may be positioned substantially mid-way between the axle assembly positions of a bogie having two axle positions spaced longitudinally in the normal direction of travel.

In a vehicle suspension system the or each elastomeric mounting may be positioned so that the vehicle load acts in the thickness direction of the or each elastomeric layer, and with the opposed edge regions being spaced apart in a transverse direction perpendicular to the normal direction of vehicle travel. Accordingly the longitudinal direction of each slot formation is parallel with the normal direction of vehicle travel. In an alternative\rive construction the longitudinal direction of each slot may be arranged transverse to the normal direction of vehicle travel.

The vehicle suspension system of the present invention is particularly suitable for tracked vehicles such as rail vehicles, and is suitable also for non-tracked vehicles.

Embodiments of the invention will now be described, by way of example

only, with reference to the accompanying diagrammatic drawings in which:-

Figure 1 is a section on line 1-1 of Figure 2 of a chevron type elastomeric mounting in accordance with a first aspect of the present invention;

Figure 2 is a section on the line 2-2 of Figure 1;

Figure 3 is a view similar to that of Figure 1, with additional details shown;

Figure 4 is a section on the line X-X of Figure 3;

Figure 5 is a section on the line 5-5 of Figure 6 of another chevron type mounting in accordance with a second embodiment of the present invention;

Figure 6 is a longitudinal section on the line 6-6 of Figure 5;

Figure 7 is a section of the second embodiment on the line 7-7 of Figure 8, and

Figure 8 is a section on the line 8-8 of Figure 7.

A chevron type mounting 10 comprises three angled metal plates 11 of V-section in cross-section, two metal end castings 12 each having a flat outer face 13 and a V-shaped inner face 14 corresponding to the inclination of a respective confronting face of a metal plate 11.

Located between said V-shaped faces and bonded thereto are four elastomeric interleaving layers 15, one layer 15 being interposed between each successive pair of V-shaped faces in an arrangement in which the metal plates and castings lie superimposed with the apex lines 16 of the respective V-shaped faces aligned. Each of the metal members and elastomeric layers has a rectangular outer profile and is longer in the apex line direction Z shown in Figure 2 than in the transverse direction Y shown in Figure 1.

Each elastomeric layer has a pair of longitudinal outer edges 17. Mid-way between those outer edges each elastomeric layer has, in the unloaded condition, a central slot 18 which extends longitudinally in the Z direction, and exhibits a double taper feature.

The slot 18 is tapered in the plan view shown in Figure 4 to be of decreasing width from an end region 19 to a central region 20, the taper being  $6^\circ$  relative to the longitudinal axis 21. Each slot is also tapered in thickness, as

shown in Figure 2, with an included taper angle of  $5^\circ$ . Each slot has a greater height at a transversely central position 22 aligned with the longitudinal axis 21 than at an outer transverse edge region 23.

Referring now to the embodiment of Figures 5 to 8, that relates to a chevron type mounting 50 which generally is similar to that of Figures 1 to 4, but has slots 51 which are different from the slots 18.

Each slot 51 comprises a central section 52 which is substantially similar to a slot 18, and a pair of side sections 53 which extend (see figure 5) towards the obtuse surface 54 of one of a pair of metal plates between which the layer 55 with the slot 51 is sandwiched.

As shown in Figures 6 and 8, the central section 52 and also each side section 53 tapers to increase in width in a direction to the ends 56 from a position 57 mid-way therebetween. At the mid-way position 57 a small, thin web 58 of rubber extends across the slot, for manufacturing convenience, and thereby divides the overall length of the slot into two zones laying at respective sides of the web.

In use the side sections provide for a relatively low initial stiffness in the transverse direction of Figures 5 and 7, and an increase with higher transverse deflection when one of the side sections closes.

## CLAIMS:

1. An elastomeric mounting for compression and shear loading comprising a plurality of metal members with the or each successive pair of metal members being spaced apart by and bonded to a layer of elastomeric material, said metal members and the or each elastomeric layer having a pair of substantially parallel and opposed edge regions, and the material of each elastomeric layer when in an unstressed condition comprising a slot-like cavity which extends substantially parallel with and spaced from said edge regions of the layer, wherein the height of the slot-like cavity tapers progressively from an end region of the or each layer of elastomeric material to a central position mid-way between longitudinal ends of the layer.
2. An elastomeric mounting according to claim 1, wherein the slot-like cavity has a maximum thickness in the direction of normal compression loading of the mounting which is less than one quarter of the maximum width of the slot as considered in a transverse direction between said opposed edge regions.
3. An elastomeric mounting according to claim 2, wherein said maximum thickness is less than one sixth of said maximum width.
4. An elastomeric mounting according to any one of the preceding claims, wherein the width of the slot region tapers progressively from a maximum width at an end region to a minimum width at a central position mid-way between the end regions.
5. An elastomeric mounting according to claim 4, wherein the taper of the width of the slot is in the range  $4^{\circ}$  to  $20^{\circ}$  as measured relative to a central longitudinal axis.
6. An elastomeric mounting according to claim 4, wherein said taper is in the range  $4^{\circ}$  to  $8^{\circ}$ .

8.

7. An elastomeric mounting according to any one of the preceding claims, wherein as considered in a transverse plane, a slot has a non-constant height which is a maximum at a central position and a minimum at transverse edge regions.
8. An elastomeric mounting according to any one of the preceding claims, wherein each slot-like cavity is positioned off-set to lie closer to one of the metal members of a pair of successive metal members.
9. An elastomeric mounting according to any one of the preceding claims, wherein the slot comprises in transverse cross section a central section and a pair of side sections each extending from the central section towards a surface of one of the metal members.
10. An elastomeric mounting according to claim 9, wherein the side sections extend towards the same metal member surface.
11. An elastomeric mounting according to claim 9 or claim 10, wherein the side sections each extend wholly to a metal member surface.
12. An elastomeric mounting according to any one of the preceding claims, and which is of the chevron type in which the metal members and elastomeric layers have confronting bonded surfaces of a V-shape in cross-section, the central, transverse portion of each slot-like cavity lying closer to the outer, obtuse angle surface of one of the V-shaped components than relative to the internal surface of the other metal member of the pair between which it is sandwiched.
13. An elastomeric mounting according to claim 12, wherein outer transverse regions of a slot lie closer to the internal surface of one of a pair of metal members than relative to the outer obtuse surface of the other metal member of the pair.
14. An elastomeric mounting according to claim 12 or claim 13 when dependent on any one of claims 9 to 11, wherein the side sections each extend to the obtuse surface of the pair of confronting obtuse and internal surfaces.

15. An elastomeric mounting according to any one of the preceding claims, wherein the or each slot-like cavity is disposed symmetrically relative to the transverse width of the mounting.

16. An elastomeric mounting according to any one of the preceding claims, wherein the or each elastomeric layer has a stiffness in the range 45 to 65 Shore A.

17. An elastomeric mounting according to claim 1 and substantially as herein described.

18. A vehicle suspension system comprising an axle assembly secured to a vehicle body by at least one elastomeric mounting in accordance with any one of the preceding claims.

19. A vehicle suspension system according to claim 18, wherein the body and axle assembly are secured to one another by a pair of said elastomeric mountings arranged spaced apart in the direction of the length of the rotational axis or axes of the vehicle wheels.

20. A vehicle suspension system according to claim 18 or claim 19, wherein the axle assembly is part of a vehicle bogie and the or each elastomeric mounting is arranged to secure the bogie to a vehicle body.

21. A vehicle suspension system according to claim 20, wherein the or each mounting is positioned substantially mid-way between the axle assembly positions of the bogie having two axle positions spaced longitudinally in the normal direction of travel.

22. A vehicle suspension system according to any one of claims 18 to 21, wherein the or each elastomeric mounting is positioned so that the vehicle load acts in the thickness direction of the or each elastomeric layer and said opposed edge regions are spaced apart in a transverse direction perpendicular to the normal direction of vehicle travel.

23. A vehicle suspension system according to claim 18 and substantially as herein described.

Amendments to the claims have been filed as follows

1. An elastomeric mounting for compression and shear loading comprising a plurality of metal members with the or each successive pair of metal members being spaced apart by and bonded to a layer of elastomeric material, said metal members and the or each elastomeric layer having a pair of substantially parallel and opposed edge regions, and the material of each elastomeric layer when in an unstressed condition comprising a slot-like cavity which extends substantially parallel with and spaced from said edge regions of the layer, wherein the height of the slot-like cavity as considered in the direction of normal compression loading of the mounting tapers progressively from an end region of the or each layer of elastomeric material to a central position mid-way between longitudinal ends of the layer.

2. An elastomeric mounting according to claim 1, wherein the slot-like cavity has a maximum height in the direction of normal compression loading of the mounting which is less than one quarter of the maximum width of the slot as considered in a transverse direction between said opposed edge regions.

3. An elastomeric mounting according to claim 2, wherein said maximum height is less than one sixth of said maximum width.

4. An elastomeric mounting according to any one of the preceding claims, wherein the width of the slot region tapers progressively from a maximum width at an end region to a minimum width at a central position mid-way between the end regions.

5. An elastomeric mounting according to claim 4, wherein the taper of the width of the slot is in the range  $4^{\circ}$  to  $20^{\circ}$  as measured relative to a central longitudinal axis.

6. An elastomeric mounting according to claim 4, wherein said taper is in the range  $4^{\circ}$  to  $8^{\circ}$ .

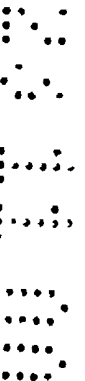

7. An elastomeric mounting according to any one of the preceding claims, wherein as considered in a transverse plane, a slot has a non-constant height which is a maximum at a central position and a minimum at transverse edge regions.

8. An elastomeric mounting according to any one of the preceding claims, wherein each slot-like cavity is positioned off-set to lie closer to one of the metal members of a pair of successive metal members.

9. An elastomeric mounting according to any one of the preceding claims, wherein the slot comprises in transverse cross section a central section and a pair of side sections each extending from the central section towards a surface of one of the metal members.

10. An elastomeric mounting according to claim 9, wherein the side sections extend towards the same metal member surface.

11. An elastomeric mounting according to claim 9 or claim 10, wherein the side sections each extend wholly to a metal member surface.

12. An elastomeric mounting according to any one of the preceding claims, wherein the or each slot-like cavity is disposed symmetrically relative to the transverse width of the mounting.

13. An elastomeric mounting according to any one of the preceding claims, wherein the or each elastomeric layer has a stiffness in the range 45 to 65 Shore A.

14. An elastomeric mounting according to claim 1 and substantially as herein described.

15. A vehicle suspension system comprising an axle assembly secured to a vehicle body by at least one elastomeric mounting in accordance with claim 1, wherein the body and axle assembly are secured to one another by a pair of said elastomeric mountings arranged spaced apart in the direction of the length of the rotational axis or axes of the vehicle wheels.

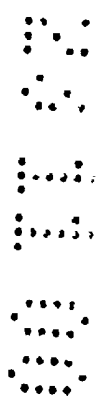



16. A vehicle suspension system according to claim 15, wherein the axle assembly is part of a vehicle bogie and the or each elastomeric mounting is arranged to secure the bogie to a vehicle body.

17. A vehicle suspension system according to claim 16, wherein the or each mounting is positioned substantially mid-way between the axle assembly positions of a bogie having two axle positions spaced longitudinally in the normal direction of travel.

18. A vehicle suspension system according to any one of claims 15 to 17, wherein the or each elastomeric mounting is positioned so that the vehicle load acts in the thickness direction of the or each elastomeric layer and said opposed edge regions are spaced apart in a transverse direction perpendicular to the normal direction of vehicle travel.

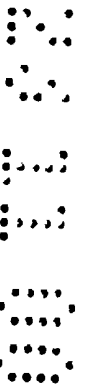



INVESTOR IN PEOPLE

Application No: GB 0022385.9  
Claims searched: 1 - 22

Examiner: Tom Sutherland  
Date of search: 31 October 2000

### Patents Act 1977 Search Report under Section 17

#### Databases searched:

UK Patent Office collections, including GB, EP, WO & US patent specifications, in:

UK CI (Ed.R): F2S (SCF)

Int CI (Ed.7): F16F 1/377, 1/387, 1/40, 1/41, 1/44, 1/54

Other:

#### Documents considered to be relevant:

Category	Identity of document and relevant passage	Relevant to claims
A	GB 1576398 (MIDLAND-ROSS)	
A	GB 1310671 (DUNLOP)	

X	Document indicating lack of novelty or inventive step	A	Document indicating technological background and/or state of the art.
Y	Document indicating lack of inventive step if combined with one or more other documents of same category.	P	Document published on or after the declared priority date but before the filing date of this invention.
&	Member of the same patent family	E	Patent document published on or after, but with priority date earlier than, the filing date of this application.