



(19) **United States**

(12) **Patent Application Publication**

Weder

(10) **Pub. No.: US 2003/0037863 A1**

(43) **Pub. Date: Feb. 27, 2003**

(54) **PROCESS FOR PRODUCING HOLOGRAPHIC MATERIAL**

Publication Classification

(76) Inventor: **Donald E. Weder**, Highland, IL (US)

(51) **Int. Cl.⁷ B32B 31/00**

(52) **U.S. Cl. 156/209; 156/277**

Correspondence Address:
DUNLAP, CODDING & ROGERS P.C.
PO BOX 16370
OKLAHOMA CITY, OK 73114 (US)

(57) **ABSTRACT**

(21) Appl. No.: **10/217,656**

(22) Filed: **Aug. 12, 2002**

Processes for producing a holographic material wherein the holographic image is formed on a polished, substantially smooth surface of a printing element and then transferred the holographic image to a substrate. A coating is applied to the smooth surface of the printing element to provide a coated surface, the coated surface is embossed or engraved to provide the holographic image, and the holographic image is then transferred to a substrate via a bonding material, thereby producing the holographic material. The holographic material may be used to provide a decorative cover for an object or item, such as a floral grouping or a potted plant.

Related U.S. Application Data

(63) Continuation of application No. 09/611,932, filed on Jul. 7, 2000, now Pat. No. 6,454,895, which is a continuation-in-part of application No. 09/372,526, filed on Aug. 11, 1999, now Pat. No. 6,372,073.

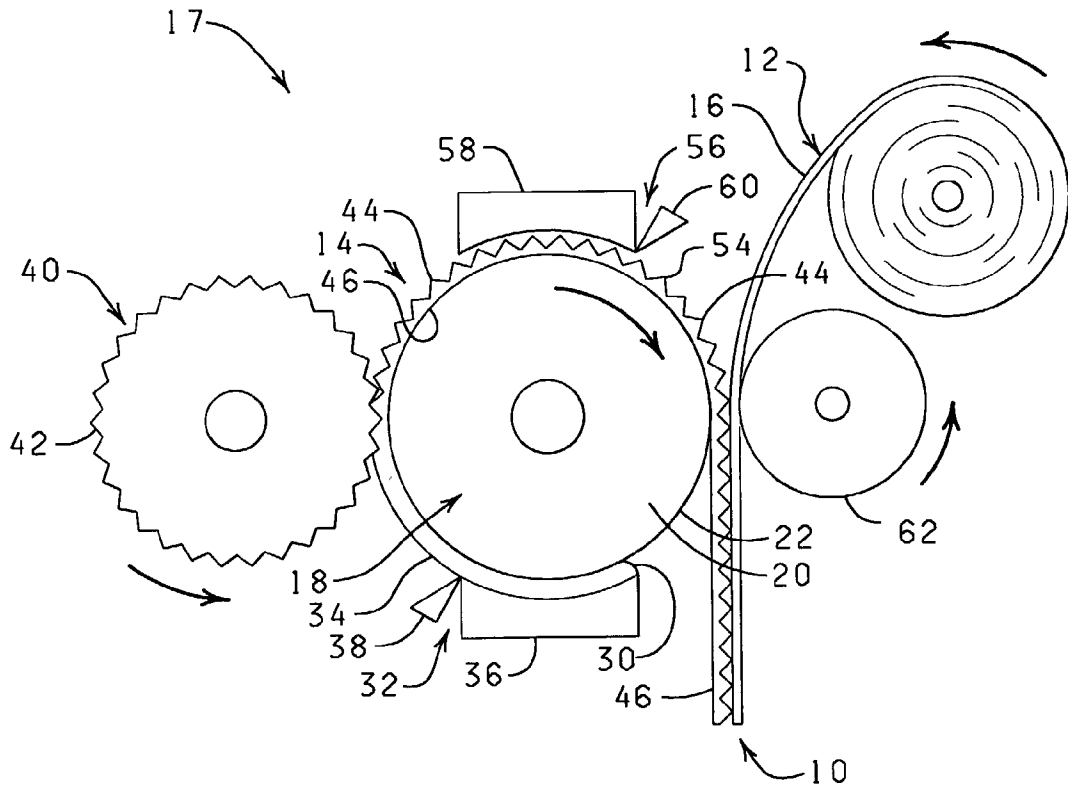

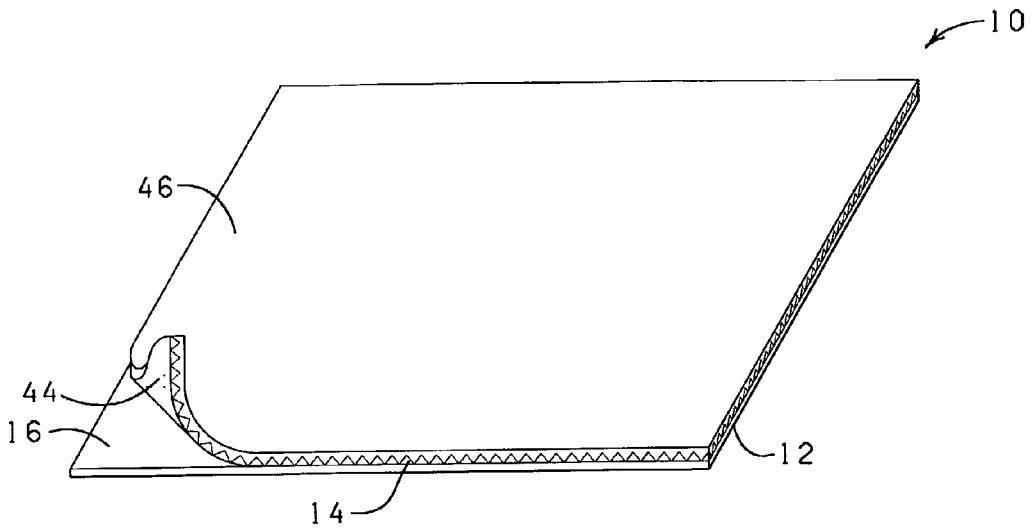

FIG. 1

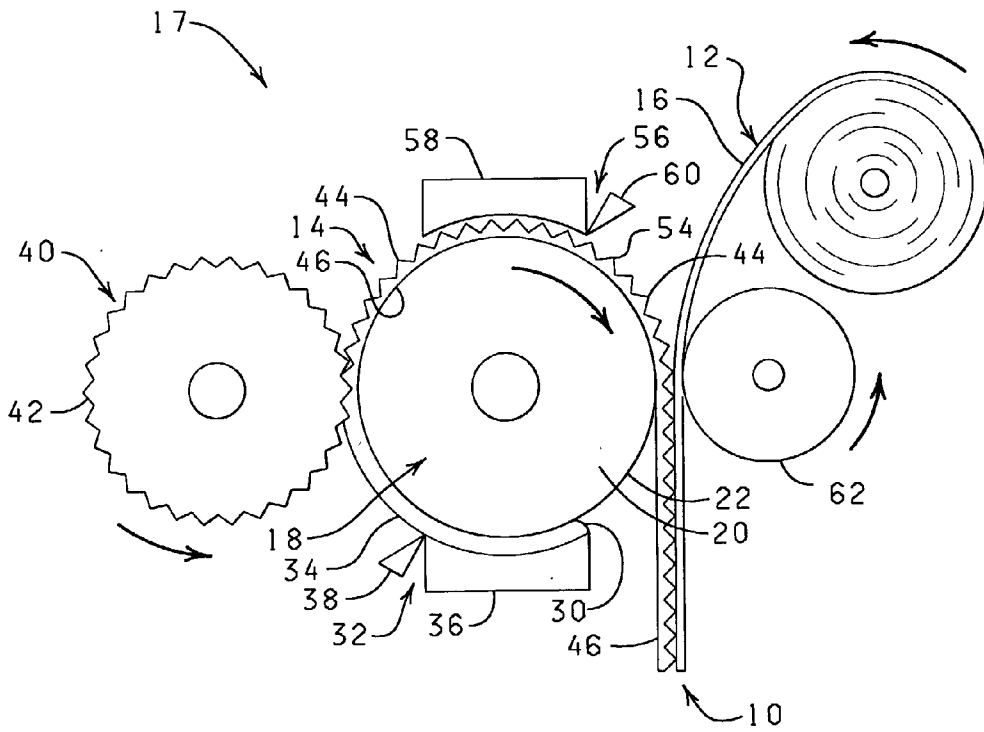

FIG. 2

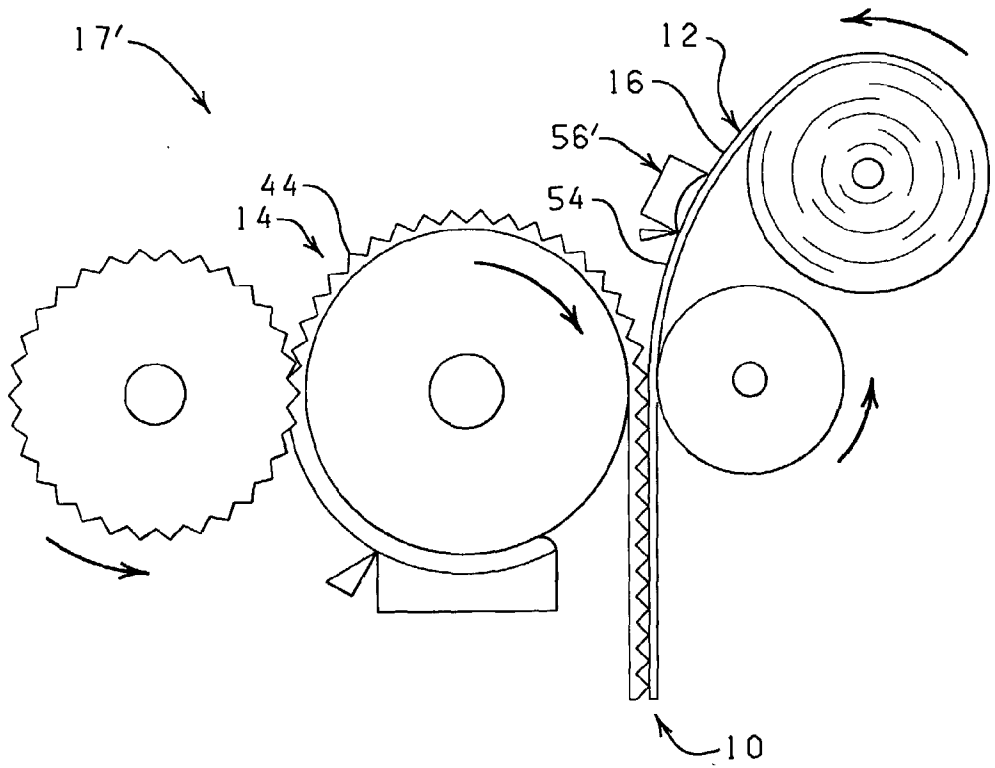

FIG. 2A

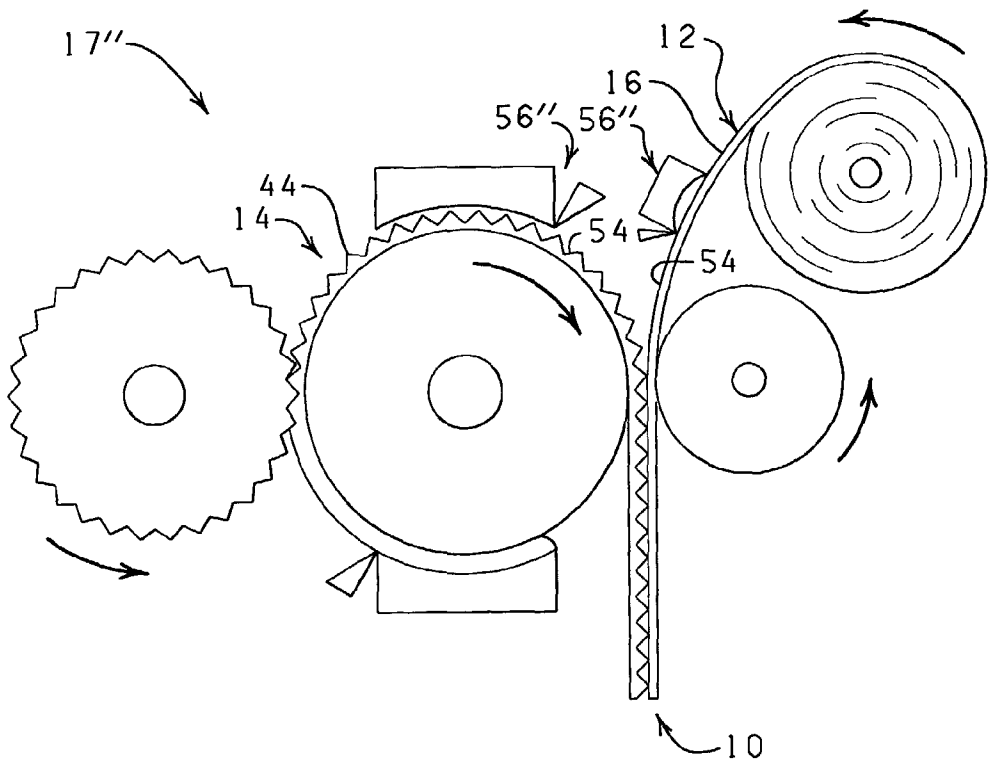

FIG. 2B

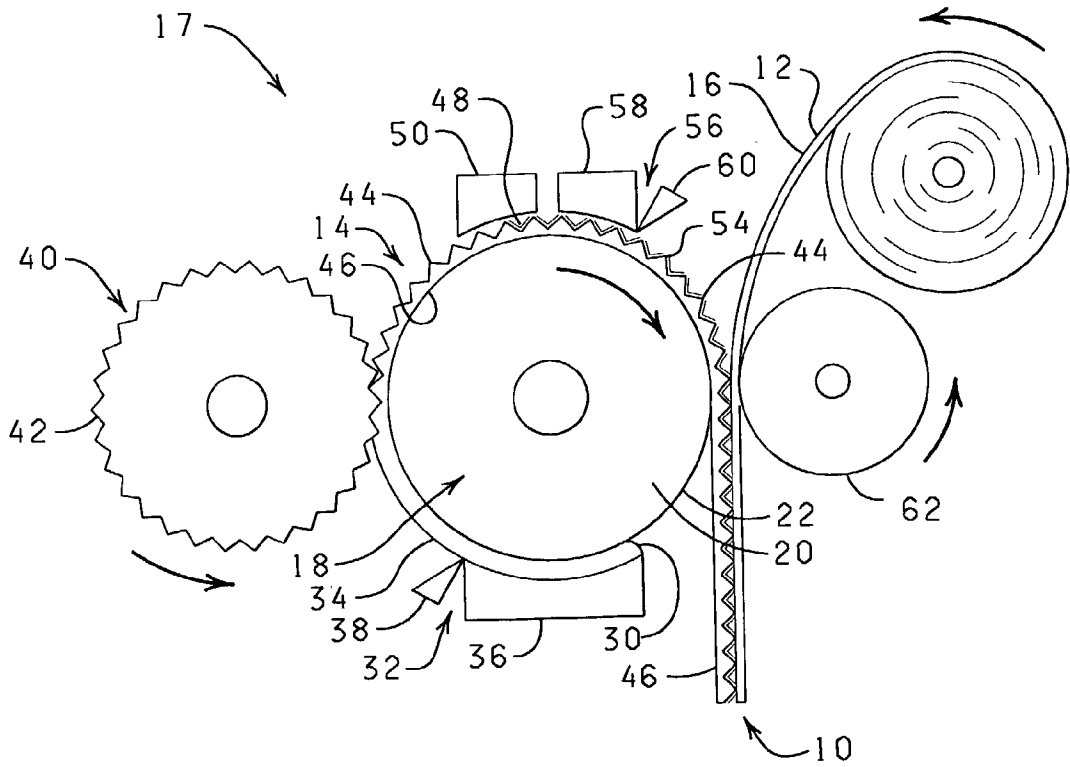

FIG. 3

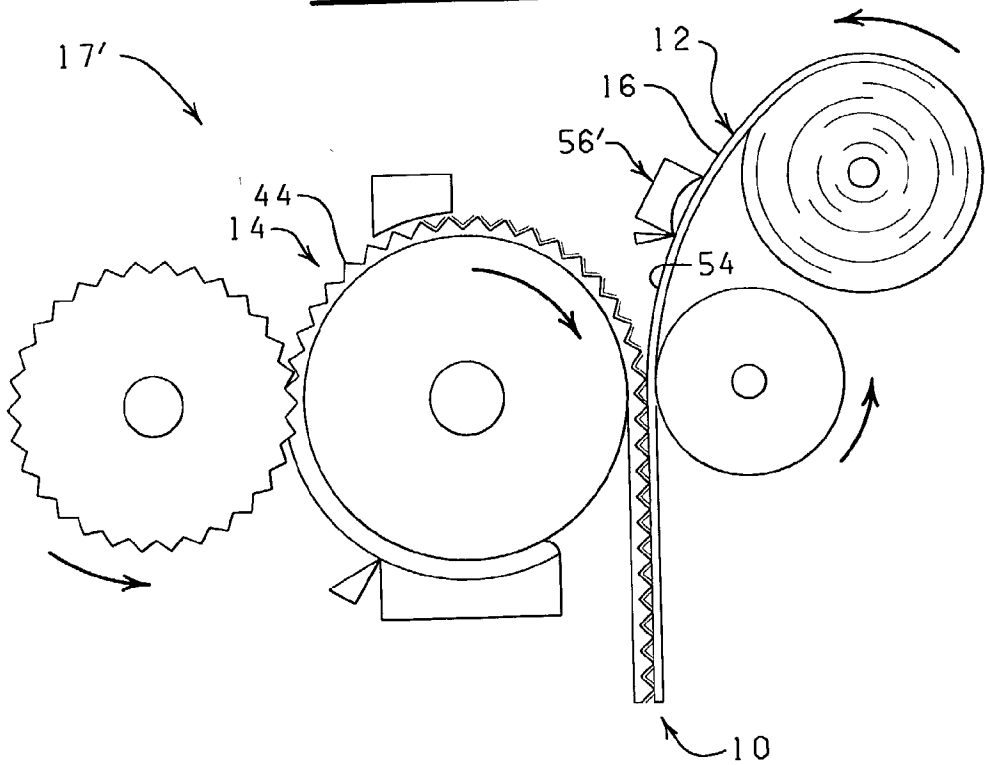

FIG. 3A

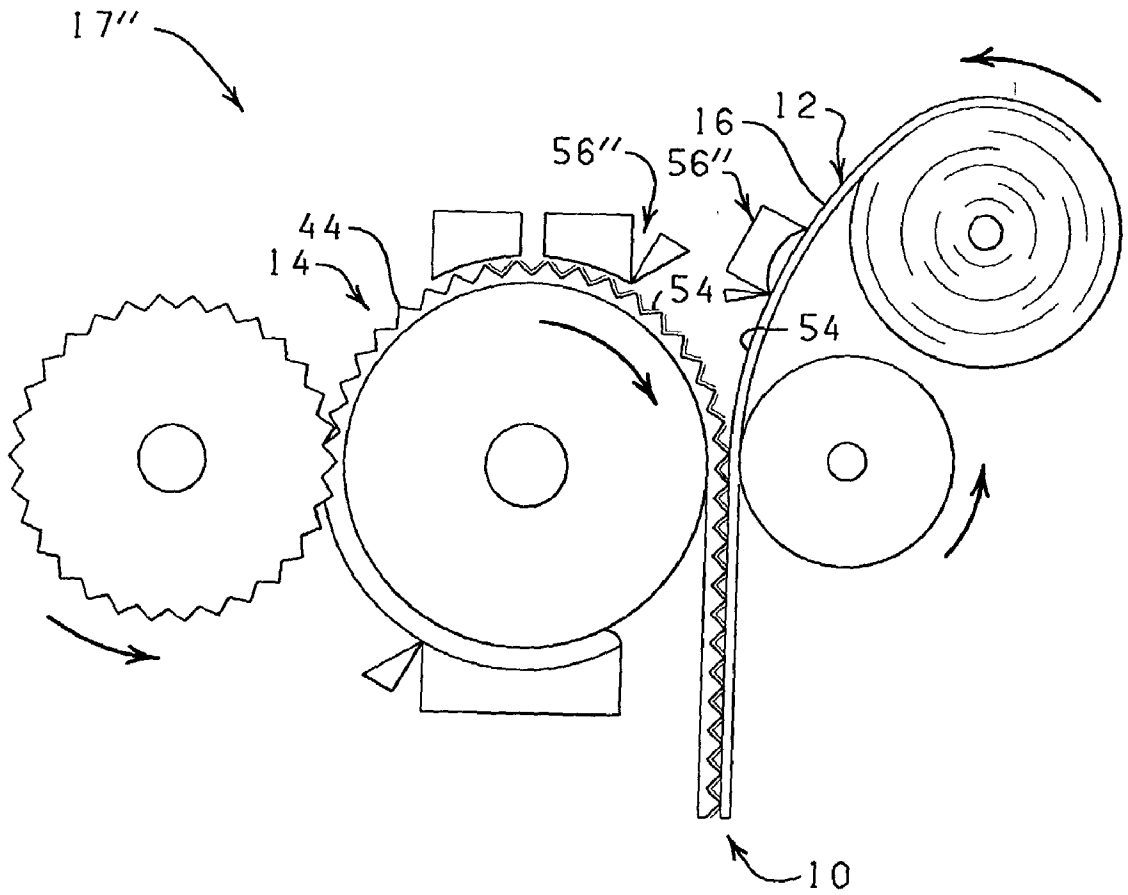
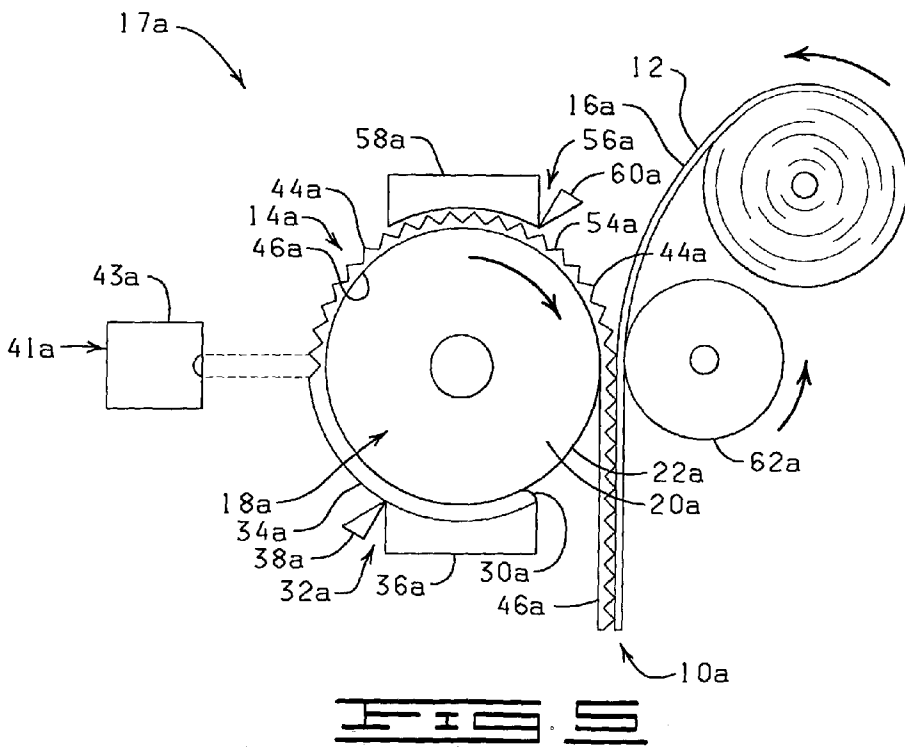
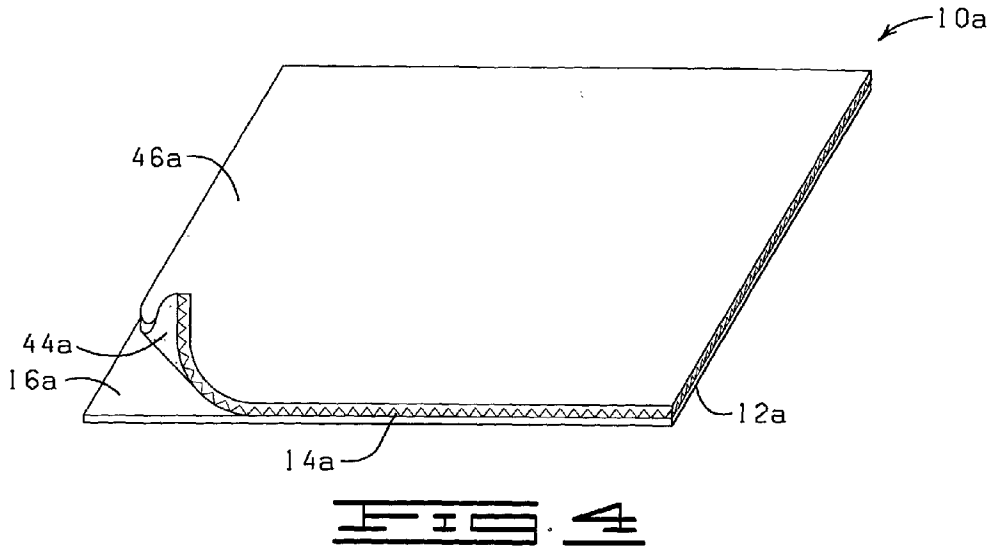
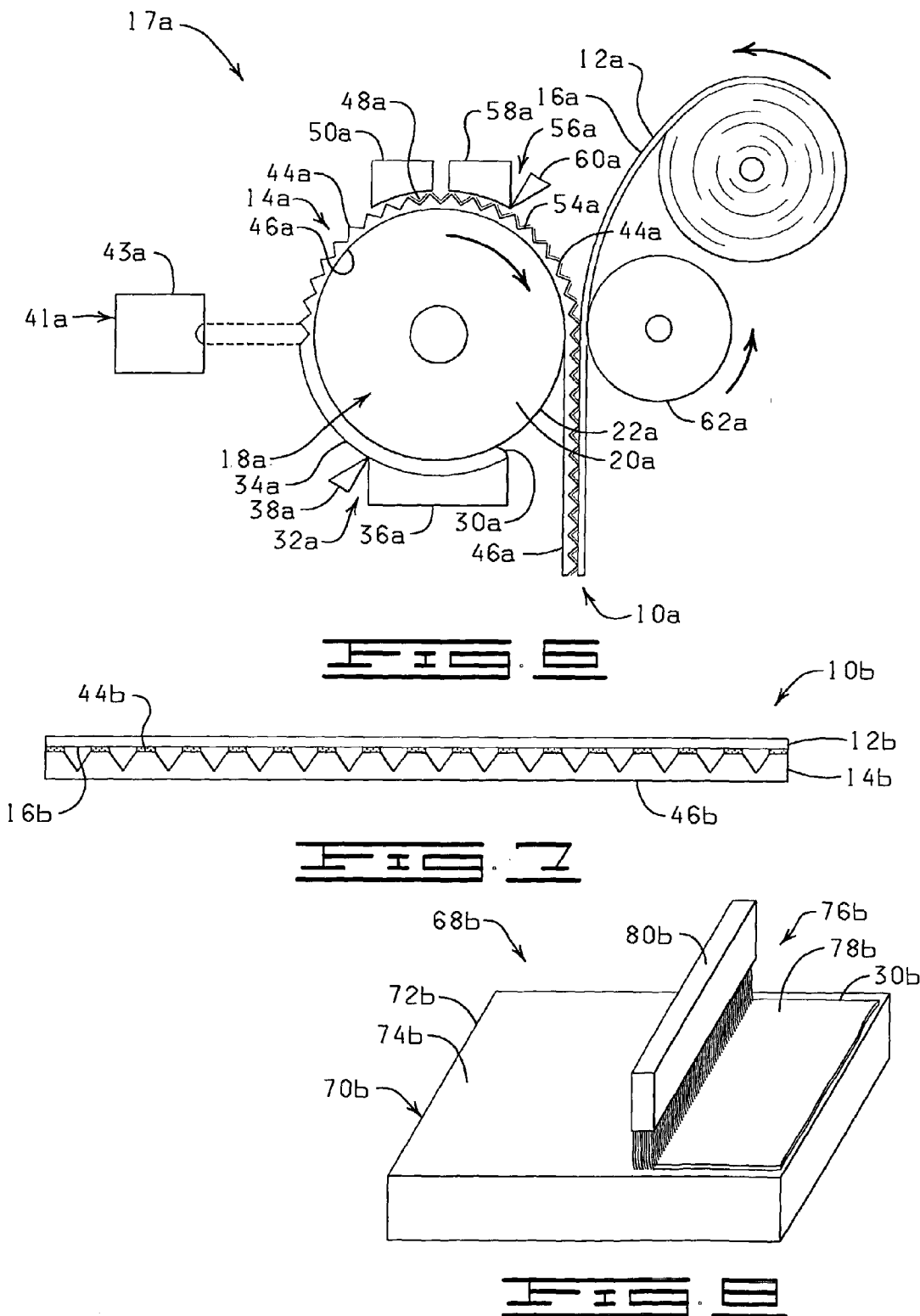

FIG. 3B





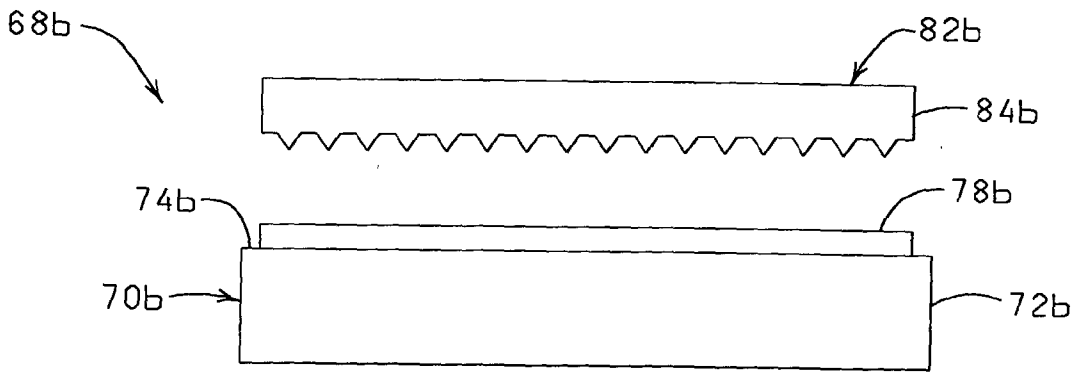

FIG. 9

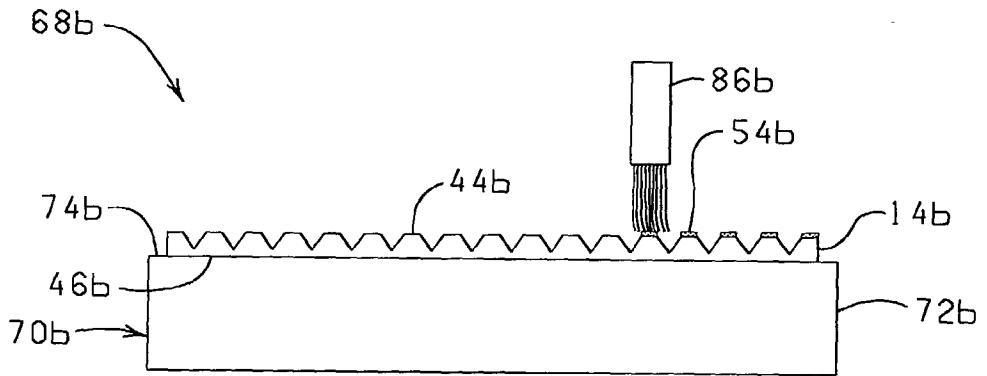

FIG. 10

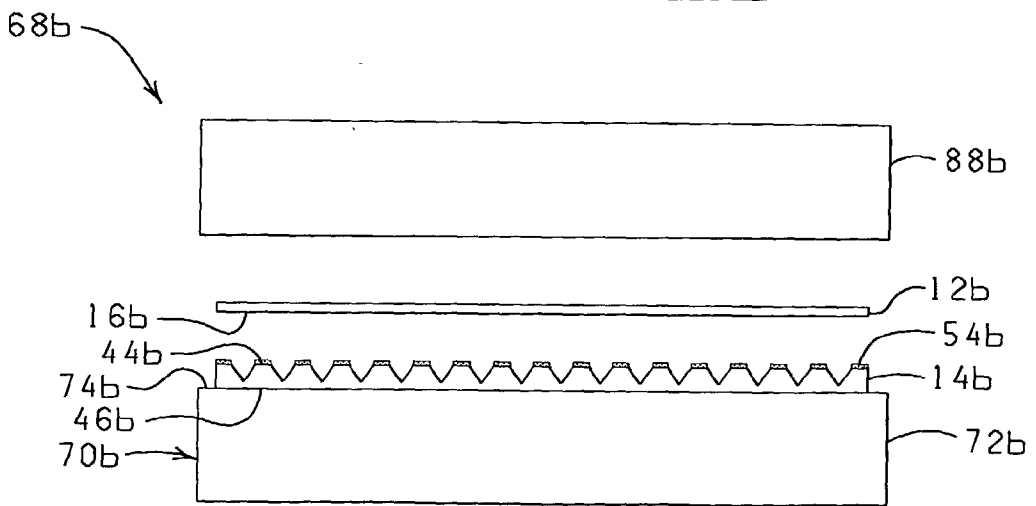

FIG. 11

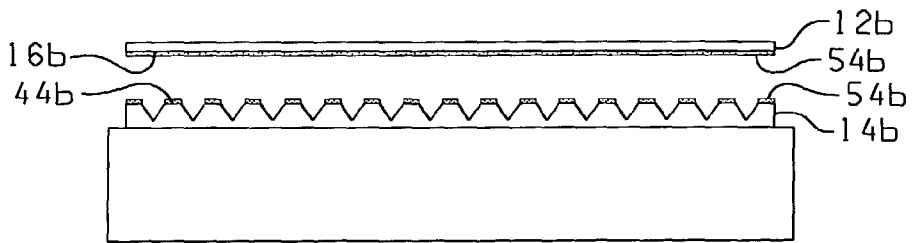
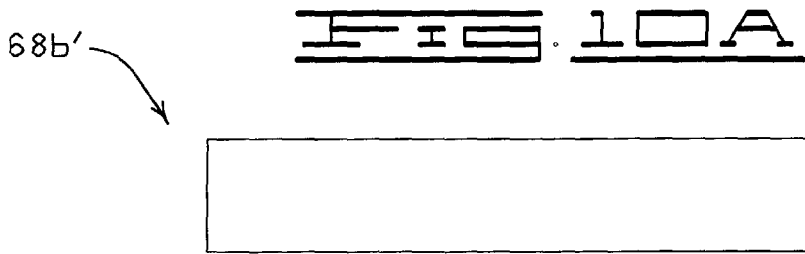
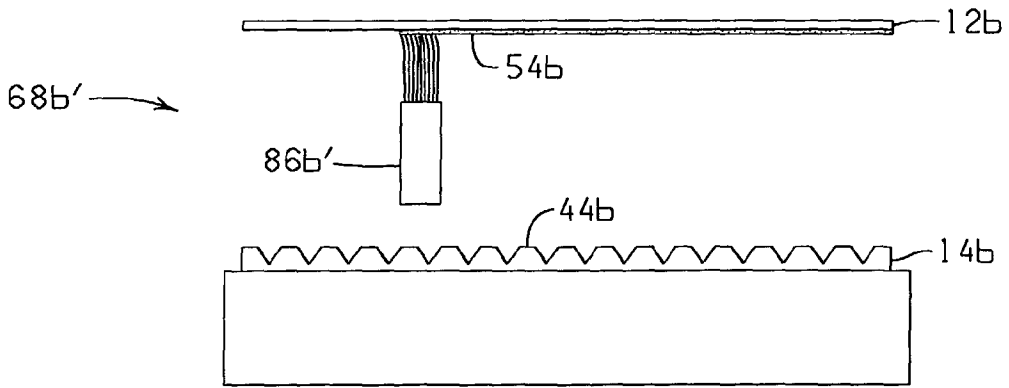

FIG. 11A

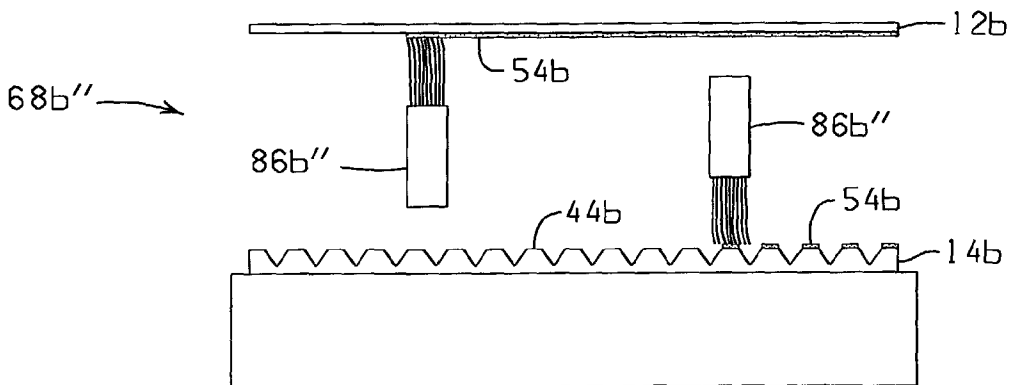

FIG. 10B

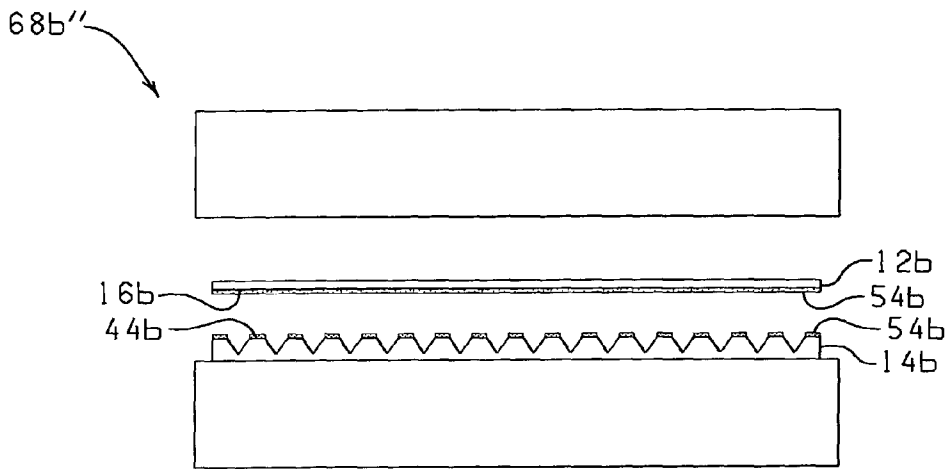

FIG. 11B

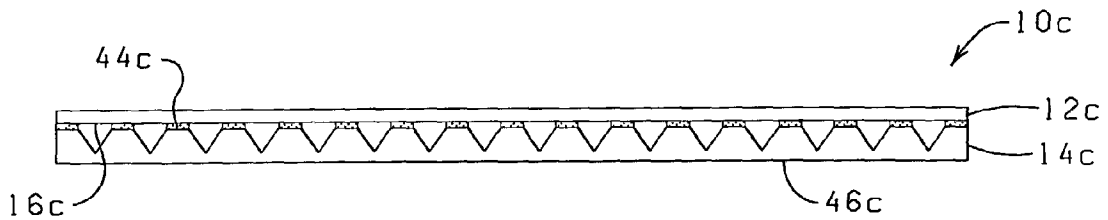

FIG. 12

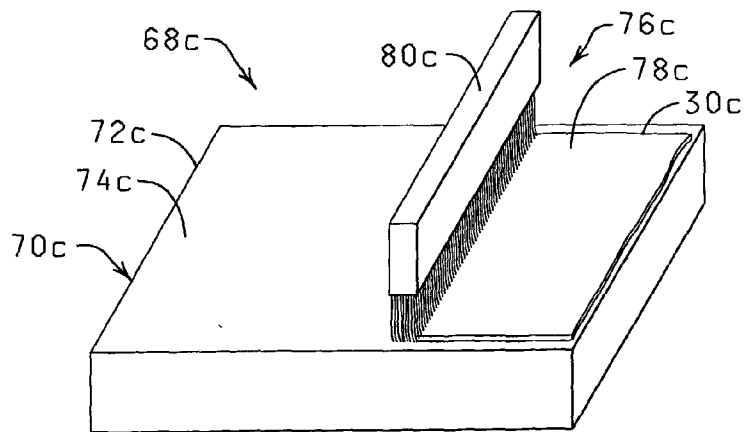

FIG. 13

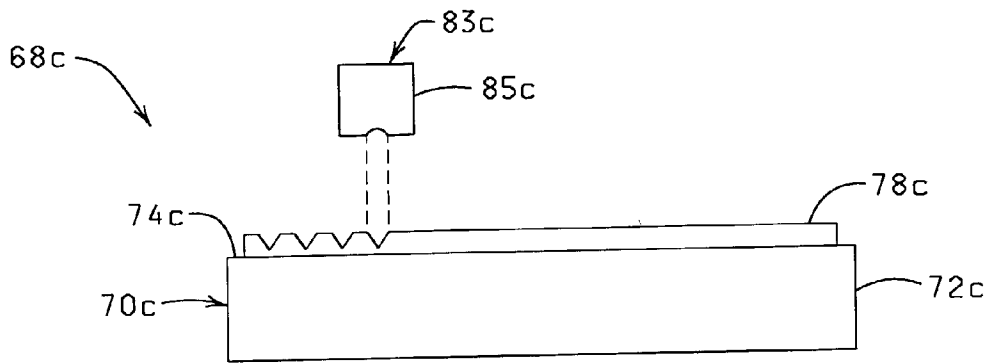

FIG. 14

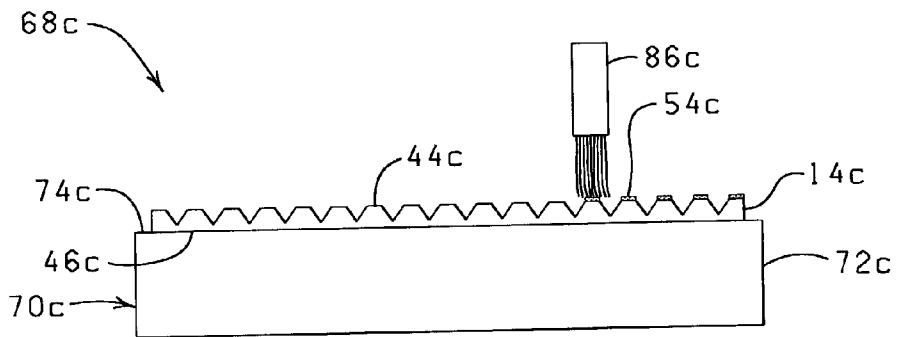

FIG. 15

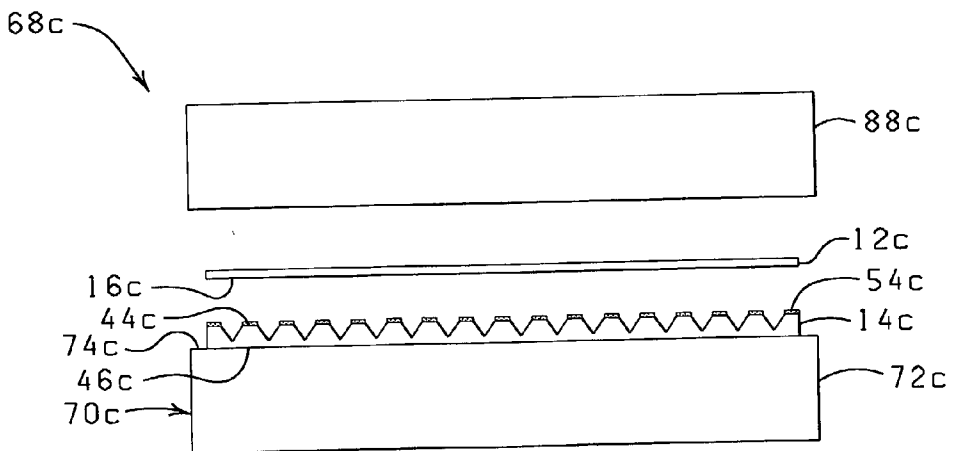

FIG. 16

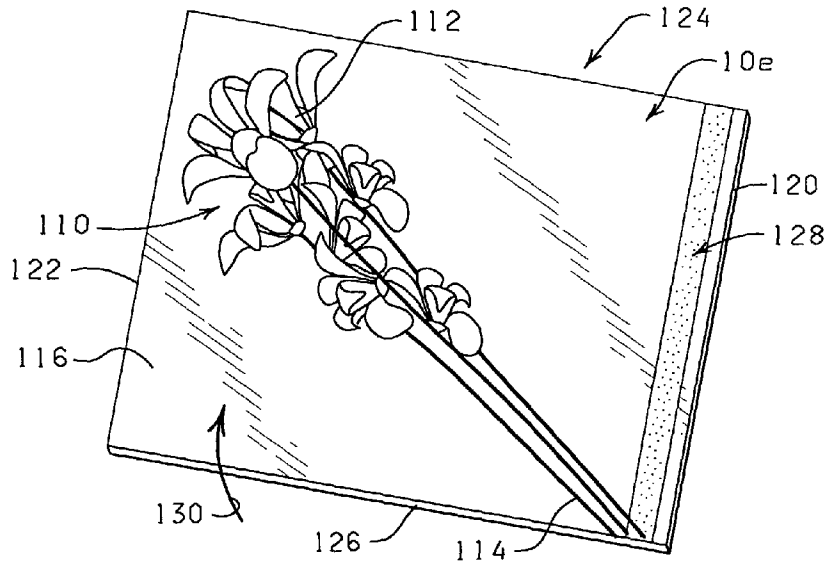

FIG. 19

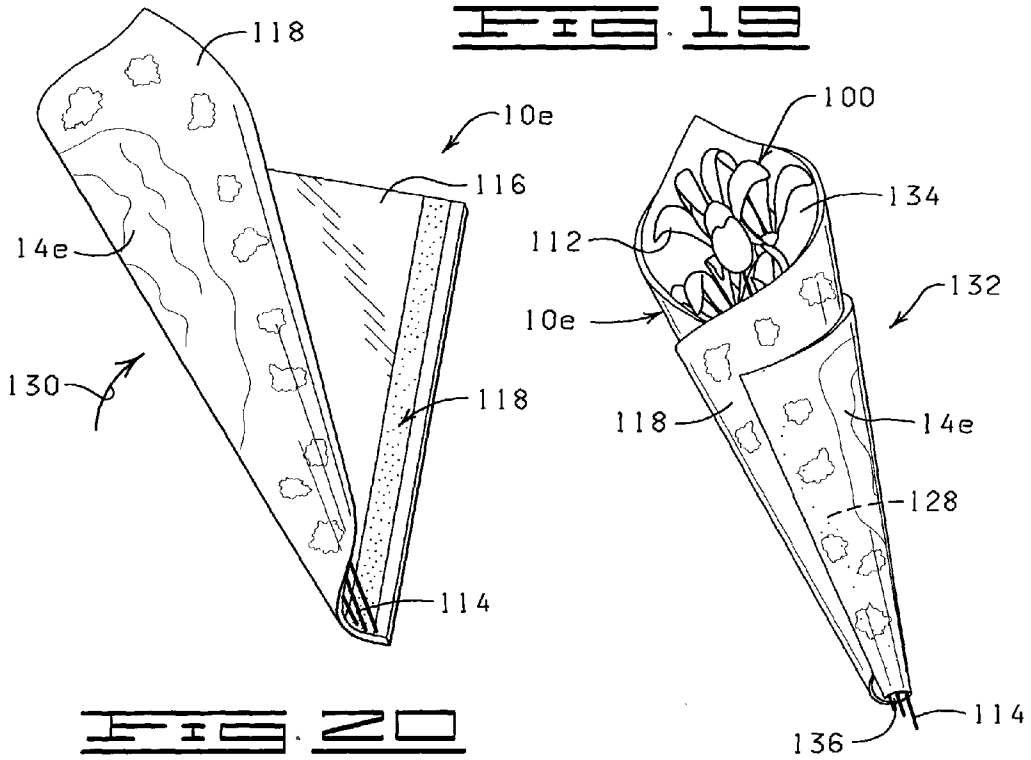

FIG. 20

FIG. 21

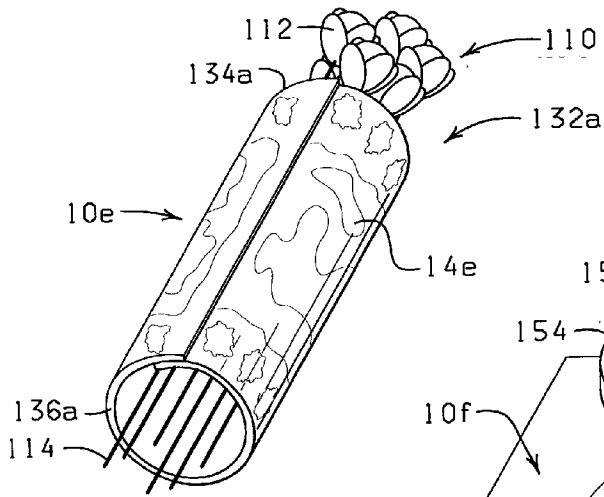

FIG. 22

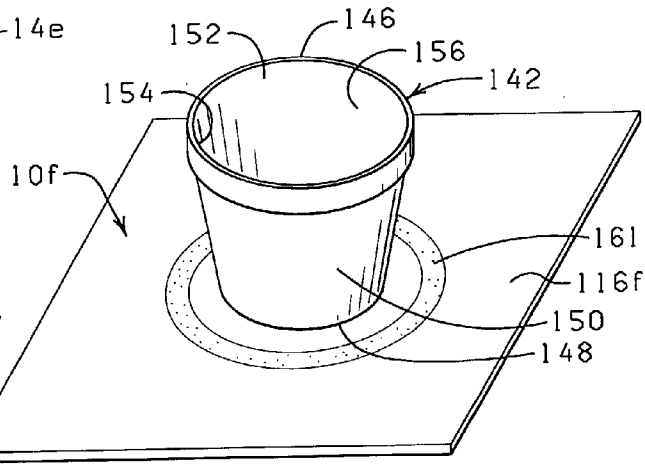

FIG. 23

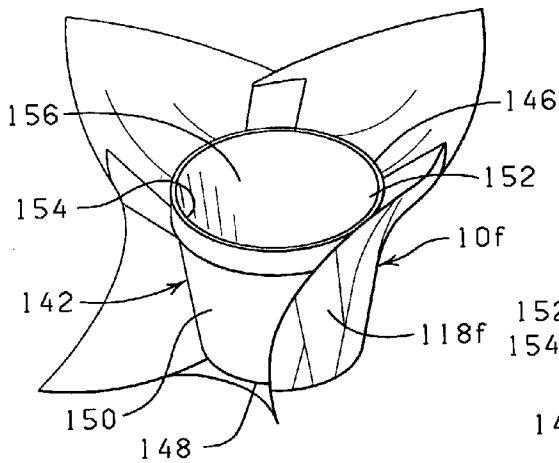

FIG. 24

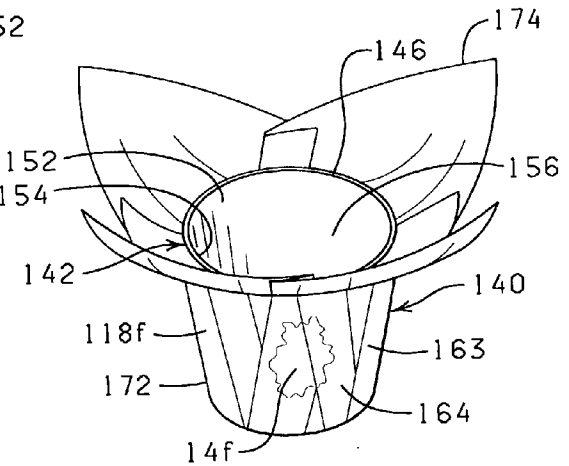

FIG. 25

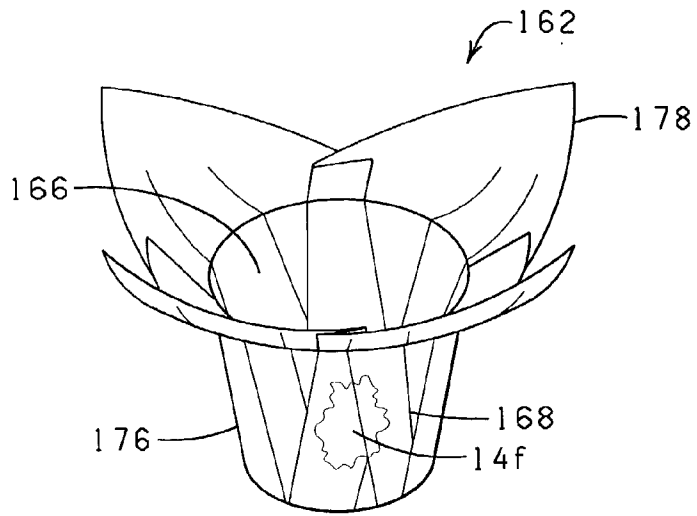

FIG. 26

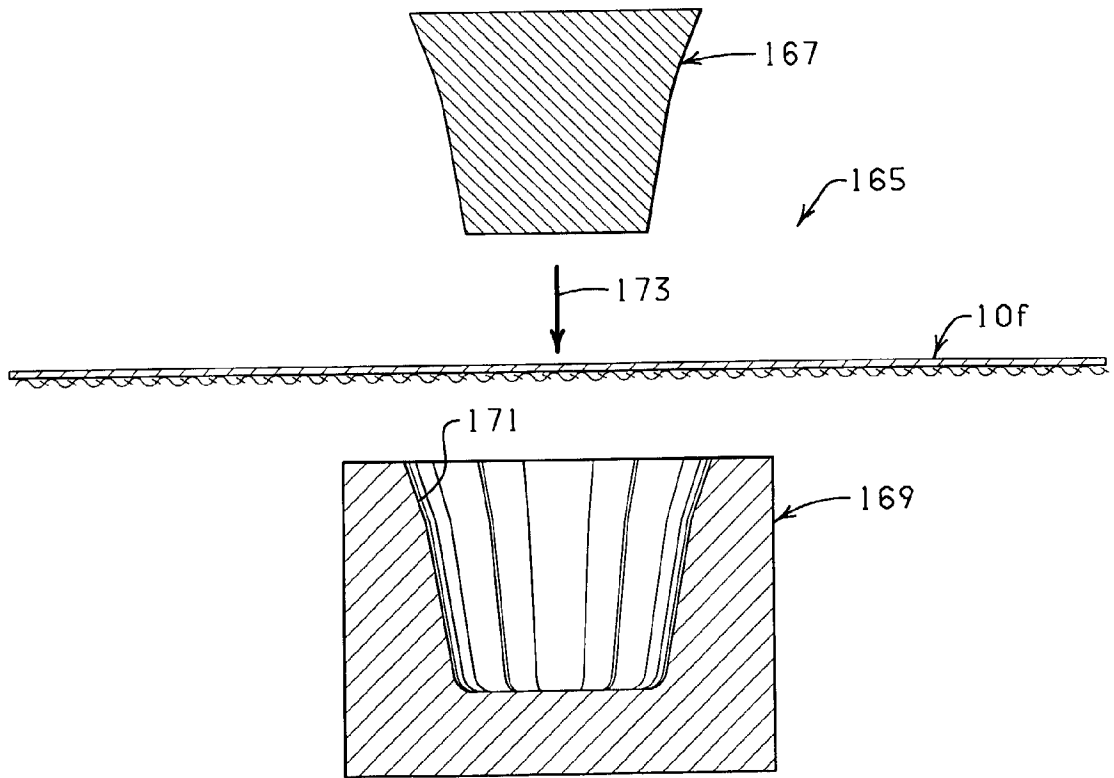

FIG. 27

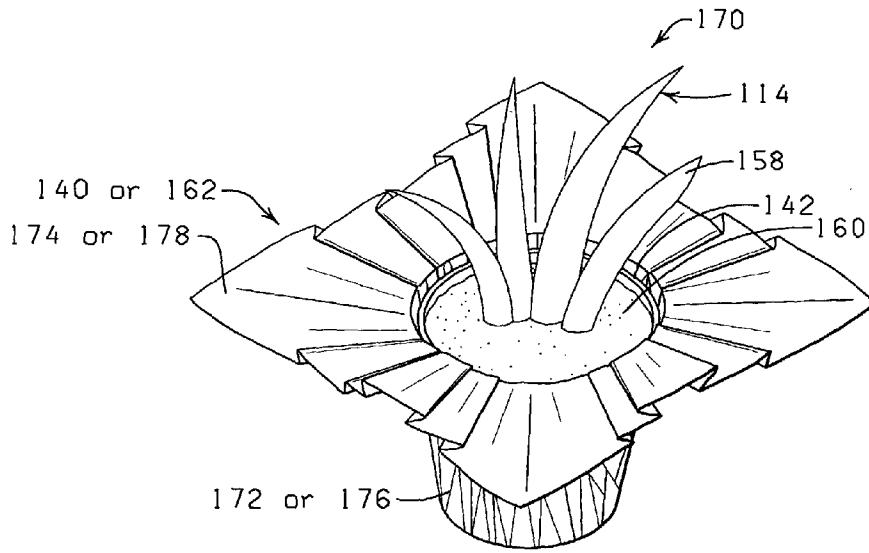

FIG. 28

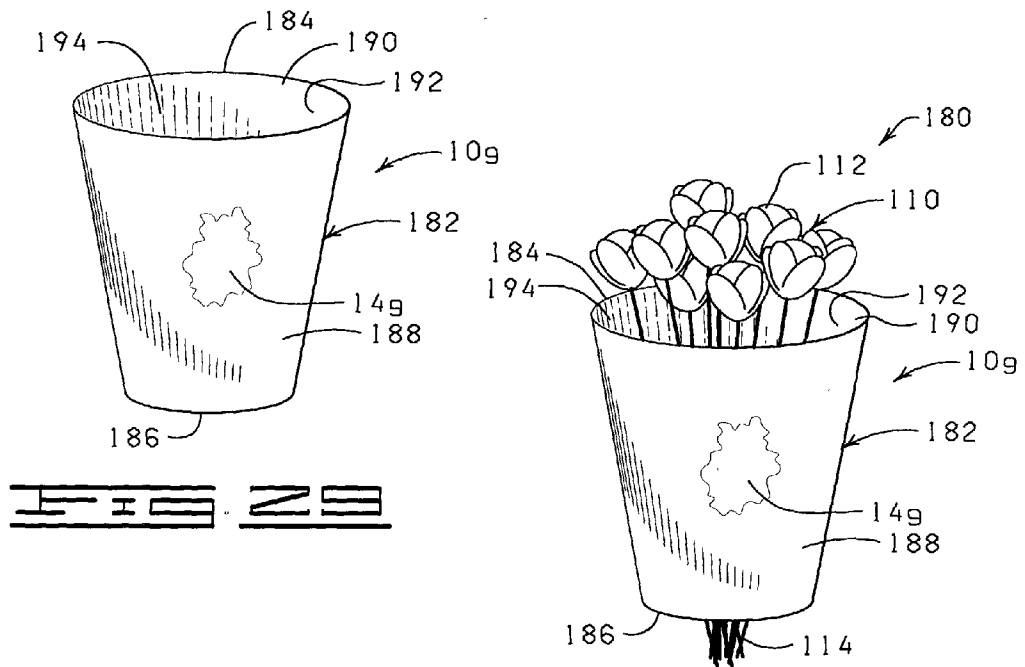
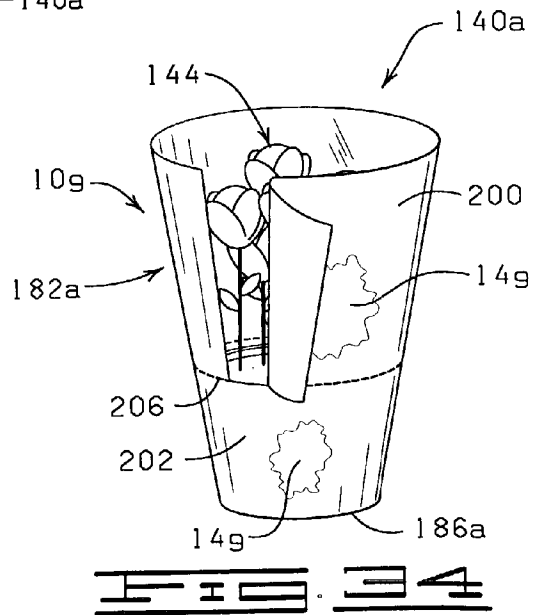
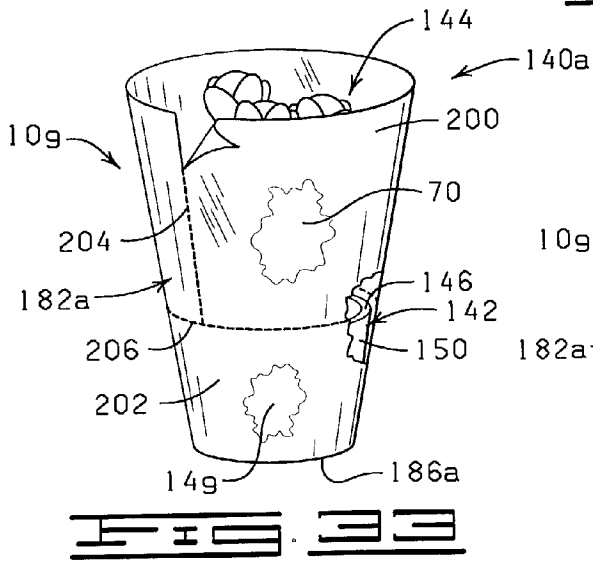
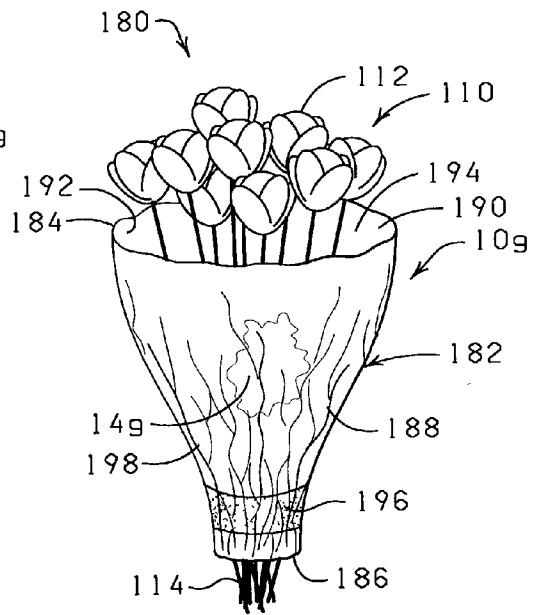
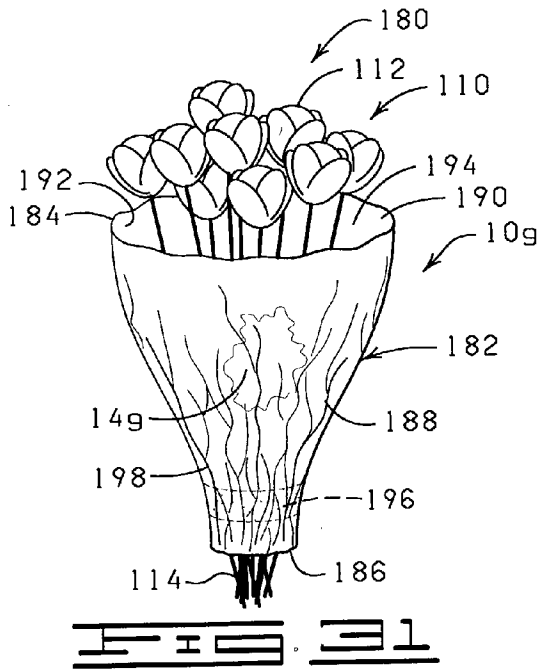
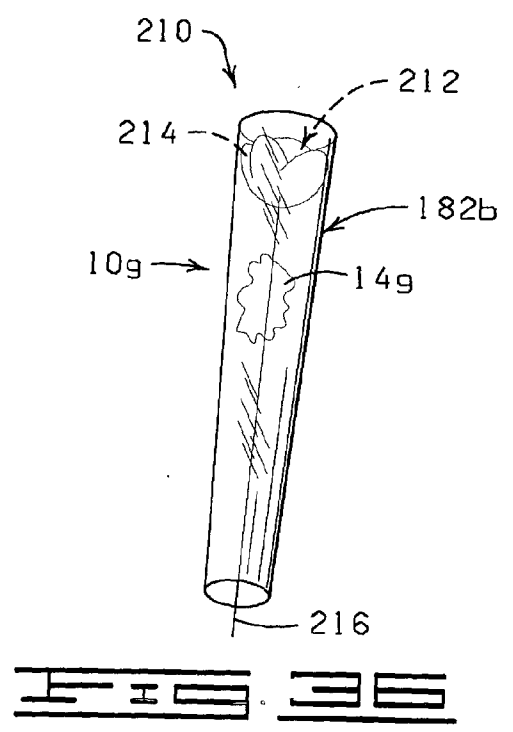
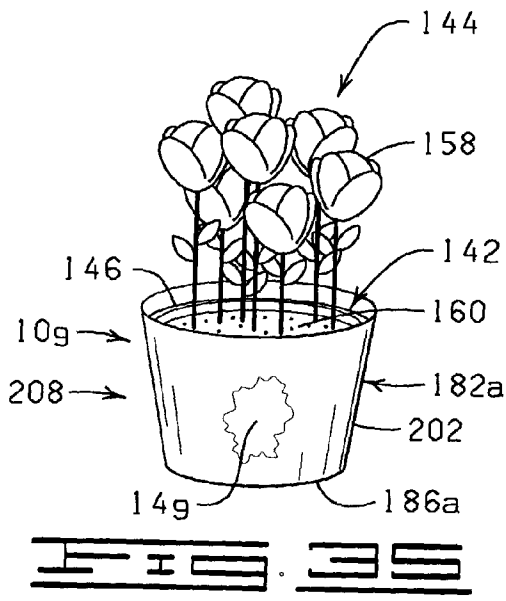

FIG. 29

FIG. 30





PROCESS FOR PRODUCING HOLOGRAPHIC MATERIAL

CROSS REFERENCE TO RELATED APPLICATIONS

[0001] This application is a divisional of U.S. Ser. No. 09/611,932, filed Jul. 7, 2002, entitled "PROCESS FOR PRODUCING HOLOGRAPHIC MATERIAL"; which is a continuation-in-part of U.S. Ser. No. 09/372,526, filed Aug. 11, 1999, entitled "PROCESS FOR PRODUCING HOLOGRAPHIC MATERIAL", now U.S. Pat. No. 6,372,073, issued Apr. 16, 2002.

STATEMENT REGARDING FEDERALLY SPONSORED RESEARCH OR DEVELOPMENT

[0002] Not applicable.

BACKGROUND OF THE INVENTION

[0003] 1. Field of the Invention

[0004] The present invention relates generally to processes for producing decorative material, and more particularly, but not by way of limitation, to processes for producing holographic material, as well as methods for using same.

[0005] 2. Brief Description of the Prior Art

[0006] Processes for producing holographic materials are well known in the art. One process involves passing a layer of plastic, for example, through a machine which imparts an image within the covering or upper strata of the plastic layer. A powdered metallic constituent or component (e.g. aluminum) is then applied thereon by a metallizing process. After metallizing, a holographic or 3-dimensional image is imparted on the metallized layer of plastic. This image is extremely pleasing and is widely used within the credit card and security industries since the resulting image is difficult to duplicate and thus assists in the prevention of fraud by counterfeiting, for example. However, images produced by this process can be quite expensive since the machines required for production of the images are complicated and costly in and of themselves. Additionally, holographic images produced by this process are usually small in size, and larger holographic images cannot be imprinted by this process. Thus, this process of producing holographic images has not been widely used outside of the credit card and novelty industry.

[0007] A process for producing large sheets of holographic material at a lower cost than the process described above involves producing the holographic image laminated to a polymeric support, contacting the holographic image on the polymeric support to a substrate such as tissue paper or foil via an adhesive, and delaminating the polymeric support, thereby transferring the holographic image from the polymeric support to the tissue paper or foil substrate. The image cannot be directly applied to a substrate having a rough surface because the rough surface of the substrate will refract light and will not have a highly reflective finish, thereby disrupting the holographic image.

[0008] Therefore, new and improved methods for producing holographic material requiring less time and expense are being sought. It is to such a process for producing holographic material that the present invention is directed.

SUMMARY OF THE INVENTION

[0009] According to the present invention, processes for producing holographic material are provided which avoid the disadvantages and defects of the prior art, making the processes more economically feasible. Broadly, processes are provided for transferring holographic images to a substrate to produce a holographic material. These processes involve producing the holographic image on a polished, substantially smooth surface and then transferring the holographic image to a substrate, thereby bypassing the need for the lamination/delamination steps used in the prior art.

[0010] In one aspect of the present invention, a printing element having a polished, substantially smooth surface is provided, and a metallic coating is applied to the smooth surface of the printing element to provide a coated surface. The coated surface is embossed or engraved to provide the holographic image on the coating, and the holographic image is then transferred to a substrate, thereby producing a holographic material.

[0011] In another aspect of the present invention, a non-metallic coating may be applied to the smooth surface of the printing element to provide a coated surface, which is then embossed or engraved to provide an image. The embossed or engraved coated surface may then be metallized, if necessary, to provide a holographic image on the coating, and the holographic image is transferred to a substrate to produce the holographic material.

[0012] The production of holographic materials in accordance with the present invention may be performed as a continuous process or as a batch process. Applications of the holographic materials produced in accordance with the present invention include wrapping a floral grouping and providing a decorative cover for an object such as a flower pot or a potted plant, decorative wrappings for various food and gift items, decorative and non-decorative elements, pigments, Christmas ornaments, etc.

[0013] An object of the present invention is to provide improved processes for producing holographic materials.

[0014] Another object of the present invention, while achieving the before-stated object, is to provide processes for producing holographic materials which do not suffer from the disadvantages of the prior art processes.

[0015] Other objects, features and advantages of the present invention will become apparent from the following detailed description when read in conjunction with the accompanying drawings and appended claims.

BRIEF DESCRIPTION OF THE DRAWINGS

[0016] FIG. 1 is a perspective view illustrating a sheet of holographic material having a holographic image embossed thereon produced by a continuous process in accordance with the present invention.

[0017] FIG. 2 is a partial schematic representation of an apparatus for producing holographic material in a continuous process, the apparatus utilizing a cylindrical drum and an embossing element.

[0018] FIG. 2A is a partial schematic representation of another apparatus for producing holographic material in a continuous process.

[0019] FIG. 2B is a partial schematic representation of yet another apparatus for producing holographic material in a continuous process.

[0020] FIG. 3 is a partial schematic representation of another apparatus for producing holographic material in a continuous process, the apparatus utilizing a cylindrical drum and an embossing element.

[0021] FIG. 3A is a partial schematic representation of yet another apparatus for producing holographic material in a continuous process.

[0022] FIG. 3B is a partial schematic representation of another apparatus for producing holographic material in a continuous process.

[0023] FIG. 4 is a perspective view illustrating a sheet of holographic material having a holographic image engraved thereon produced by another continuous process in accordance with the present invention.

[0024] FIG. 5 is a partial schematic representation of an apparatus for producing holographic material in a continuous process, the apparatus utilizing a cylindrical drum and an engraving element.

[0025] FIG. 6 is a partial schematic representation of another apparatus for producing holographic material in a continuous process, the apparatus utilizing a cylindrical drum and an engraving element.

[0026] FIG. 7 is a side elevational view illustrating a sheet of holographic material having a holographic image embossed thereon produced by a batch process in accordance with the present invention.

[0027] FIG. 8 is a diagrammatic representation of a flat plate used to produce sheets of holographic material having a holographic image embossed thereon in accordance with the present invention, the flat plate having a coating disposed on a surface thereof.

[0028] FIG. 9 is a diagrammatic representation of the flat plate with a coated surface of FIG. 8 and an embossing plate for embossing the coated surface of the flat plate to provide an embossed coated surface with a holographic image thereon.

[0029] FIG. 10 is a diagrammatic representation of the flat plate of FIG. 9 having an embossed coated surface and a holographic image thereon, the embossed coated surface of the flat plate having a bonding material applied thereto.

[0030] FIG. 10A is a diagrammatic representation of the flat plate of FIG. 9 having an embossed coated surface and a holographic image thereon, and a substrate having a bonding material applied thereto.

[0031] FIG. 10B is a diagrammatic representation of the flat plate of FIG. 9 having an embossed coated surface and a holographic image thereon and a substrate, wherein bonding material is applied to the embossed coated surface of the flat plate and to the substrate.

[0032] FIG. 11 is a diagrammatic representation of the flat plate of FIG. 10 having an embossed coated surface with a holographic image thereon and a bonding material applied thereto, the bonding material bondingly connecting the embossed coated surface to a substrate to produce a sheet of

holographic material constructed from the coating containing a holographic image and the substrate.

[0033] FIG. 11A is a diagrammatic representation of the flat plate having an embossed coated surface with a holographic image thereon and the substrate of FIG. 10A, the bonding material disposed on the substrate bondingly connecting the holographic image to the substrate to produce a sheet of holographic material.

[0034] FIG. 11B is a diagrammatic representation of the flat plate having an embossed coated surface with a holographic image thereon and the substrate of FIG. 10B, the bonding material bondingly connecting the holographic image to the substrate to produce a sheet of holographic material.

[0035] FIG. 12 is a side elevational view illustrating a sheet of holographic material having a holographic image engraved thereon produced by another batch process in accordance with the present invention.

[0036] FIG. 13 is a diagrammatic representation of a flat plate used to produce sheets of holographic material having a holographic image engraved thereon in accordance with the present invention, the flat plate having a coating disposed on a surface thereof.

[0037] FIG. 14 is a diagrammatic representation of the flat plate with a coated surface of FIG. 13 and an engraving element for engraving the coated surface of the flat plate to provide an engraved coated surface with a holographic image thereon.

[0038] FIG. 15 is a diagrammatic representation of the flat plate of FIG. 14 having an engraved coated surface and a holographic image thereon, the engraved coated surface of the flat plate having a bonding material applied thereto.

[0039] FIG. 16 is a diagrammatic representation of the flat plate of FIG. 15 having an engraved coated surface with a holographic image thereon and a bonding material applied thereto, the bonding material bondingly connecting the engraved coated surface to a substrate to produce a sheet of holographic material constructed from the coating containing a holographic image and the substrate.

[0040] FIG. 17 is a perspective view of a roll of holographic material constructed in accordance with the present invention and illustrating a knife assembly being actuated by an actuator to cut at least a portion of the roll of holographic material into elongated strips of holographic material.

[0041] FIG. 18 is a perspective view of the roll of holographic material of FIG. 17, showing the knife assembly being actuated in a second direction, so as to cut the elongated strips of holographic material into segments of holographic material.

[0042] FIG. 19 is a perspective view of a floral grouping disposed on a sheet of holographic material.

[0043] FIG. 20 is a perspective view of the floral grouping of FIG. 19 being wrapped in the sheet of holographic material in one method of wrapping with the sheet of holographic material.

[0044] FIG. 21 is a perspective view of the floral grouping wrapped in the sheet of holographic material in a conical fashion.

[0045] FIG. 22 is a perspective view of another method of using a sheet of holographic material to wrap a floral grouping, wherein the floral grouping is wrapped in the sheet of holographic material in a cylindrical fashion.

[0046] FIG. 23 is a perspective view of a sheet of holographic material having a flower pot disposed thereon.

[0047] FIG. 24 is a perspective view of the sheet of holographic material of FIG. 23 partially wrapped about the flower pot.

[0048] FIG. 25 is a perspective view of the sheet of holographic material of FIG. 23 wrapped about the flower pot.

[0049] FIG. 26 is a perspective view of a pre-formed decorative pot cover formed from a sheet of holographic material.

[0050] FIG. 27 is a diagrammatic, cross-sectional view of a male and female mold having a sheet of holographic material disposed therebetween for forming the preformed decorative pot cover of FIG. 26.

[0051] FIG. 28 is a perspective view of a pre-formed decorative pot cover formed from a sheet of holographic material wherein the pre-formed decorative pot cover has a potted plant disposed therein.

[0052] FIG. 29 is a perspective view of a sleeve for wrapping about a floral grouping, wherein the sleeve is constructed from a holographic material in accordance with the present invention.

[0053] FIG. 30 is a perspective view of a wrapper comprising the sleeve of FIG. 29 and a floral grouping disposed therein, with a bloom portion of the floral grouping disposed adjacent a first end of the sleeve and a stem portion of the floral grouping extending from a second end of the sleeve.

[0054] FIG. 31 is a perspective view of a modified wrapper similar to the wrapper of FIG. 30 but having a bonding material disposed on the inner peripheral surface of the sleeve, and showing the wrapper crimped about the stem portion of the floral grouping, the crimped portion forming overlapping folds.

[0055] FIG. 32 is a perspective view of a modified wrapper similar to the wrapper of FIG. 30 but having a bonding material disposed on the outer peripheral surface of the sleeve, and showing the wrapper crimped about the stem portion of the floral grouping, the crimped portion forming overlapping folds.

[0056] FIG. 33 is a perspective view of a wrapper formed from the holographic material of the present invention wherein the wrapper comprises a flower pot and a sleeve for covering the flower pot wherein the sleeve is provided with vertical and circumferential perforations.

[0057] FIG. 34 is a perspective view of the wrapper of FIG. 33 wherein the vertical perforations of the sleeve are torn open and the circumferential perforations of the sleeve are partially torn.

[0058] FIG. 35 is a perspective view of the wrapper of FIGS. 33 and 34 wherein an upper portion of the sleeve has been torn away and a remaining lower portion of the sleeve forms a decorative flower pot cover.

[0059] FIG. 36 is a perspective view of a wrapper formed from the holographic material of the present invention wherein the wrapper comprises a sleeve sized to wrap a floral grouping having a single bloom and a single stem and a floral grouping having a single bloom and a single stem.

DETAILED DESCRIPTION OF THE INVENTION

The Embodiments of FIGS. 1-6

[0060] Referring now to the drawings, shown in FIG. 1 and designated therein by the reference numeral 10 is a sheet of holographic material constructed in accordance with the present invention by a continuous process. The sheet of holographic material 10 comprises a substrate 12 having a holographic design or image 14 formed thereon. The holographic image 14 provides the sheet of holographic material 10 with a holographic or 3-dimensional appearance.

[0061] The term "holographic image" as used herein is to be understood to mean a three-dimensional image most visible from an oblique angle. The unique properties of holographic images are that they appear to float in space, are true-to-life and can change perspective, that is, permit one to look around corners and watch hidden features of the image come to light.

[0062] Further, the "holographic image" can be in any geometric form, or any combination of geometric forms, for example, squares, round spots, triangles, rectangles, octagons, or the like, or any non-geometric, asymmetrical or fanciful forms, or any combination thereof, for example, but not by way of limitation, hearts, balloons, flowers, lace, slogans, logos, print (any combination of letters and/or numbers), signs, human forms (real and fictional), animal forms (real and fictional), cartoon characters, and/or plant forms. Such holographic images may include a color, or a portion of a color, or a combination of colors and designs. Alternatively, at least a portion of the holographic image may be colorless, translucent, transparent, opaque, pearlescent, iridescent, or the like.

[0063] The term "substrate" when used herein means a sheet of material capable of receiving the holographic image 14 and which provides stability to the holographic image 14. The substrate 12 of the sheet of holographic material 10 may be flexible or non-flexible. The substrate 12 can be constructed of any suitable material capable of receiving a holographic image, such as polymeric film, foil, paper, tissue, laminations thereof and combinations thereof. The substrate 12 includes a surface 16 which may be substantially rough and textured or substantially smooth. For example, tissue paper, kraft paper and high density polyethylene film often have rough surfaces, while foil and chrome-coat paper typically have smooth surfaces.

[0064] The thickness of the substrate 12 can vary widely. Generally, however, the substrate 12 has a thickness in a range from about 0.0002 mil to about 30 mil, and more desirably from about 0.1 mil to about 20 mil.

[0065] The substrate 12 may have various printings, colorings, coatings, embossings, texturizing, flocking and/or metallic finishes, or other decorative surface ornamentation applied separately or simultaneously or may be characterized totally or partially by pearlescent, translucent, trans-

parent, iridescent, or other finishes. Each of the above-named characteristics may occur alone or in combination, and when present in combination, such characteristics may be in or out of register with one another.

[0066] Referring now to **FIGS. 2 and 3**, an apparatus **17** for continuously producing the holographic material **10** is schematically illustrated. As will be more fully described hereinafter, the holographic material **10** is produced using a printing element **18**. The printing element **18** may be provided with a smooth surface or a rough surface. When the printing element **18** is provided with a smooth surface, the need to produce the holographic image on a substrate having a smooth surface, such as required by the prior art methods, is substantially eliminated.

[0067] The term "printing element" as used herein means any element having a surface capable of having a holographic image produced thereon whereby the holographic image can be transferred to a substrate without substantially distorting the holographic image. Thus, the printing element **18** for producing the holographic material **10** utilizing the apparatus **17** may be, for example, but not limited to, a cylindrical drum, a roller and the like. The printing element **18** may be constructed of any suitable material capable of having a polished, substantially smooth surface and which is capable of having the holographic image formed thereon for transfer to a desired substrate. The printing element **18** may be constructed of chrome, stainless steel, tool steel and the like. The printing element **18** may also be constructed in part of a resilient or non-resilient material such that the printing element **18** is provided with a resilient or non-resilient surface.

[0068] The printing element **18** illustrated in **FIGS. 2 and 3** is a cylindrical drum **20** having a smooth surface **22**. The cylindrical drum **20** permits the holographic material **10** to be continuously produced. A coating **30** capable of receiving a holographic image is applied to the smooth surface **22** of the cylindrical drum **20** by a coating assembly **32**, thereby providing a coated surface **34** of the cylindrical drum **20**. The coating assembly **32** is illustrated as comprising a coating pan **36** and a reverse gravure doctor blade **38**. The thickness of the coating **30** on the coated surface **34** of the cylindrical drum **20** can be controlled and maintained within preselected limits by the reverse gravure doctor blade **38** of the coating assembly **32**.

[0069] It will be understood that other methods of applying the coating **30** to the smooth surface **22** of the cylindrical drum **20** may be employed, such as spraying, brushing, etc.

[0070] The term "coating" as used herein is to be understood to mean a malleable film, ink or lacquer which is able to be embossed or engraved to receive a holographic image on at least a portion thereof. For example, the coating **30** may be a metallic material such as metallic polymeric film, metallic, iridescent pigment, foil, metallized lacquer and combinations thereof. The coating **30** may also be a non-metallic material such as polymeric film, foil, lacquer and combinations thereof. The coating **30** may also consist of metallized film chopped into glitter and mixed with a lacquer to provide an ink or lacquer as the coating **30**. When the coating **30** is a nonmetallic material, the process for producing the holographic material **10** in accordance with the present invention may include an additional step of metallizing the coated surface **34** of the cylindrical drum **20**,

which will be described in detail below. The step of metallizing the non-metallic coated surface **30** will not be required when a non-metallic material employed as the coating **30** possesses the reflective properties necessary to highlight a holographic image. Examples of non-metallic coatings **30** possessing such characteristics include iridescent pigments and inks or lacquers containing metallized film glitter.

[0071] The term "lacquer" as used herein means a coating substance consisting of resinous materials, such as cellulose esters, cellulose ethers, shellac, gum, alkyd resins and the like, which are dissolved in a solvent that evaporates rapidly on application such as ethyl alcohol, thereby leaving a tough, adherent film. Lacquers which are useful in the present invention are mixtures, such as, but not limited to, lacquers produced by mixing styrene-acrylic emulsions, such as Lucidene 603 and Lucidene 395 (Morton International, Inc., 100 North Riverside Plaza, Chicago, Ill. 60606) with a non-ionic surfactant, such as Surfynol 465 (Air Products and Chemicals, Inc., 7201 Hamilton Boulevard, Allentown, Pa. 18195-1501) and ammonia (G. S. Robbins and Company, 126 Chouteau Avenue, St. Louis, Mo. 63102). The lacquer produced as described above may also contain a wax emulsion in water, such as Liquitron 440 (Carrol Scientific, Inc., 5401 S. Dansher Road, Countryside, Ill. 60525).

[0072] The coated surface **34** of the cylindrical drum **20** is then embossed by an embossing element **40**, such as an embossing drum **42**. Embossing elements are used to produce materials to decorate or cover articles by depressing, carving, raising, or printing designs, patterns, etc. so that at least a portion of the design, pattern, etc. is raised above the surface of the material. Embossing elements and methods for embossing materials are well known in the art; thus, no further discussion of the embossing element **40** or embossing methods need be set forth.

[0073] Embossing of the coated surface **34** of the cylindrical drum **20** produces a holographic image **14** on the coated surface **34** of the cylindrical drum **20**. The holographic image **14** is provided with a first surface **44** and a second surface **46** which is substantially adjacent the smooth surface **22** of the cylindrical drum **20**.

[0074] As shown in **FIG. 3**, if the coating **30** used to provide the coated surface **34** of the cylindrical drum **20** is formed of a non-metallic material which does not possess reflective properties necessary to provide the holographic image **14**, a metallic constituent or component **48** is applied to the embossed coated surface **34** of the cylindrical drum **20** to provide the holographic image **14**. The metallic constituent or component **48** can be applied to the embossed coated surface **34** of the cylindrical drum **20** by any suitable method, such as by discharging the metallic constituent or component **48** from a reservoir **50**. Metallic constituents or components which may be employed to metallize the embossed coated surface **34** of the cylindrical drum **20** are known in the art and include powdered metals such as powdered aluminum.

[0075] Once the holographic image has been produced, a bonding material **54** may be applied to the holographic image **14**, the substrate **12**, or both. **FIGS. 2 and 3** illustrate applying the bonding material **54** to the first surface **44** of the holographic image **14** by a bonding material applicator **56**. The bonding material applicator **56** comprises a pan **58** and

a reverse gravure doctor blade **60** for removing excess bonding material **54** and controlling the thickness of the bonding material **54** so as to insure a substantially uniform coating of bonding material **54** on the first surface **44** of the holographic image **14** present on the cylindrical drum **20**. The bonding material **54** applied to the first surface **44** of the holographic image **14** is contacted with the surface **16** of the substrate **12**, thereby bondingly contacting the holographic image **14** to the substrate **12** and producing the holographic material **10**.

[0076] The term "bonding material" when used herein may be an adhesive, such as a pressure sensitive adhesive, or a cohesive. Where the bonding material is a cohesive, a similar cohesive material must be placed on the adjacent surface for bondingly contacting and bondingly engaging with the cohesive material. The term "bonding material" may also be materials which are heat sealable and, in this instance, the adjacent portions of the materials must be brought into contact and then heat must be applied to effect the seal. The term "bonding material" when used herein also means a lacquer, which may be the coating **30** described above. In this instance, heat, sound waves, or vibrations may be applied to effect the sealing of the lacquer. In this way, the coating **30** may both receive the holographic image **14** and effect sealing of the holographic image **14** to the substrate **12**, thereby producing the holographic material **10**.

[0077] To bondingly secure the holographic image **14** to the substrate **12** and to transfer the holographic image **14** from the smooth surface **22** of the cylindrical drum **20** to the substrate **12**, various methods may be employed. For example, heat and/or pressure may be applied to effect the seal between the holographic image **14** and the substrate **12**. As shown in FIGS. 2 and 3, a nip formed by opposing rollers of the cylindrical drum **20** and a sealing drum **62** may sandwich the holographic image **14** and the substrate **12** to effect a seal between the substrate **12** and the holographic image **14**. In addition, the sealing drum **62** may be a heated roller to aid in effecting the seal between the holographic image **14** and the substrate **12**.

[0078] The holographic material **10** is then removed from the smooth surface **22** of the cylindrical drum **20**. Methods of removing the holographic material **10** from the cylindrical drum **20** are known in the art. The holographic material **10** produced by the continuous process **17** may be present in different forms such as a roll or sheets of holographic material **10**.

[0079] Following production of the holographic material **10**, the holographic material **10** may be modified by various methods, such as lamination of a transparent polymeric film thereto, as described in detail herein below.

[0080] It will be understood that other methods of bondingly securing and sealing the holographic image **14** and the substrate **12** which may be employed with the apparatus **17** for continuously producing the holographic material **10** as described herein may be employed in this process, and is not limited to the method described herein.

[0081] Shown in FIGS. 2A and 3A is another method of bondingly securing and sealing the holographic image **14a** and the substrate **12a**, wherein the method utilizes an apparatus **17'** for continuously producing the holographic material **10**, wherein the apparatus **17'** is substantially simi-

lar to the apparatus **17** described hereinbefore with reference to FIGS. 2 and 3, except that the bonding material **54** is applied to the surface **16** of the substrate **12** rather than to the first surface **44** of the holographic image **14**. The bonding material **54** is applied to the surface **16** of the substrate **12** by a bonding material applicator **56'** which is substantially similar to the bonding material applicator **56** described hereinbefore with reference to FIGS. 2 and 3.

[0082] While the bonding material **54** is depicted in FIGS. 2-3 and 2A-3A as being applied to either the holographic image **14** or the substrate **12**, respectively, it will be understood that the bonding material **54** may be applied to both the holographic image **14** and the substrate **12**. Shown in FIGS. 2B and 3B is an apparatus **17''** which is substantially similar to the apparatus **17** shown in FIGS. 2 and 3 and the apparatus **17'** shown in FIGS. 2A and 3A and described hereinbefore, except that the apparatus **17''** is provided with two bonding material applicators **56''** which apply bonding material **54** to both the first surface **44** of the holographic image **14** and to the surface **16** of the substrate **12**. In this manner, a cohesive may be used as the bonding material **54**, allowing for greater control in bondingly connecting the holographic image **14** to the substrate **12** to form the holographic material **10**.

[0083] Shown in FIG. 4 is a sheet of holographic material **10a** which is similar to the sheet of holographic material **10** illustrated in FIG. 1 and described in detail hereinbefore, except that the holographic image **14a** of the sheet of holographic material **10a** is produced by engraving rather than embossing. The sheet of holographic material **10a** comprises a substrate **12a** having a surface **16a** and a holographic image **14a** formed thereon, the holographic image **14a** having a first surface **44a** and a second surface **46a** wherein the first surface **44a** of the holographic image **14a** is bondingly connected to the surface **16a** of the substrate **12a**. The sheet of holographic material **10a** is produced continuously utilizing an apparatus **17a** which is shown in FIGS. 5 and 6 and which is substantially similar to the apparatus **17** illustrated in FIGS. 2 and 3 and described in detail previously, except that an engraving element **41a**, such as a laser **43a**, is employed to produce the holographic image **14a** of the sheet of holographic material **10a**, rather than the embossing element **40** shown in FIGS. 2 and 3.

[0084] Briefly, a coating **30a** capable of receiving a holographic image is applied to a smooth surface **22a** of a cylindrical drum **20a** by a coating assembly **32a**, thereby providing a coated surface **34a** of the cylindrical drum **20a**. The coating assembly **32a** is illustrated as comprising a coating pan **36a** and a reverse gravure doctor blade **38a**. The coated surface **34a** of the cylindrical drum **20a** is then engraved by an engraving element **41a**, such as a laser **43a**. Engraving elements are used to cut or etch letters, patterns, designs, etc. in or on a surface of a material. Engraving elements and methods for engraving materials are well known in the art; thus, no further discussion of the engraving element **41a** or engraving methods need be set forth.

[0085] As shown in FIG. 5, engraving of the coated surface **34a** of the cylindrical drum **20a** produces a holographic image **14a**, which is provided with the first and second surfaces **44a** and **46a**, respectively, wherein the second surface **46a** is substantially adjacent the smooth surface **22a** of the cylindrical drum **20a**.

[0086] As shown in FIG. 6, if the coating 30a is formed of a non-metallic material which does not possess reflective properties necessary to provide the holographic image 14a, a metallic constituent or component 48a is applied to the engraved coated surface 34a of the cylindrical drum 20a to provide the holographic image 14a by any suitable method, such as by discharging the metallic constituent or component 48a from a reservoir 50a.

[0087] As shown in FIGS. 5 and 6, a bonding material 54a is applied to the first surface 44a of the holographic image 14a by a bonding material applicator 56a comprising a pan 58a and a reverse gravure doctor blade 60a. The bonding material 54a applied to the first surface 44a of the holographic image 14a is contacted with the surface 16a of the substrate 12a, thereby bondingly connecting the holographic image 14a to the substrate 12a and producing the sheet of holographic material 10a.

[0088] While the bonding material 54a is depicted as being applied to the first surface 44a of the holographic image 14a, it will be understood that the bonding material 54a may be applied to the surface 16a of the substrate 12a, or to both the first surface 44a of the holographic image 14a and to the surface 16a of the substrate 12a. Application of the bonding material 54a to the substrate 12a or to both the substrate 12a and the holographic image 14a will be in a substantially similar manner to that described herein previously for application of the bonding material 54 to the substrate 12 by the apparatus 17 described hereinbefore with reference to FIGS. 2 and 3 or for application of the bonding material 54 to both the substrate 12 and the holographic image 14 by the apparatus 17' described hereinbefore with reference to FIGS. 2A and 3A.

[0089] The holographic image 14a is bondingly secured and transferred to the substrate 12a by any suitable method known in the art. As shown in FIGS. 5 and 6 for example only, a nip is formed by opposing rollers of the cylindrical drum 20a and a sealing drum 62a which sandwiches and effects a seal between the holographic image 14a and the substrate 12a. The holographic material 10a is then removed from the smooth surface 22a of the cylindrical drum 20a by any method known in the art, and the holographic material 10a produced by such processes may be present in different forms, such as a roll or sheets of holographic material 10a.

The Embodiments of FIGS. 7-16

[0090] Shown in FIG. 7 is a sheet of holographic material 10b constructed in accordance with the present invention by a batch process which utilizes an apparatus 68b. The sheet of holographic material 10b is similar to the sheet of holographic material 10 described hereinbefore, and comprises a substrate 12b having a surface 16b and having a holographic image 14b formed thereon, the holographic image 14b having a first surface 44b and a second surface 46b. The first surface 44b of the holographic image 14b is bondingly connected to the surface 16b of the substrate 12b. The apparatus 68b for producing the sheet of holographic material 10b in a batch process is illustrated in FIGS. 8-11 and described in detail hereinafter.

[0091] The sheet of holographic material 10b is produced using a printing element 70b. The printing element 70b may be provided with a smooth surface or a rough surface. When the printing element 70b is provided with a smooth surface,

the need to produce the holographic image on a substrate having a smooth surface, such as required by the prior art methods, is substantially eliminated. The printing element 70b for producing the sheet of holographic material 10b by the batch process utilizing the apparatus 68b may be a plate, a platen press and the like. The printing element 70b may be constructed of any suitable material capable of having the holographic image formed thereon for transfer to a desired substrate. Desirably, the printing element 70b is constructed of a material capable of having a polished, substantially smooth surface; however, it will be understood that the printing element 70b may be provided with a substantially rough surface which is capable of having the holographic image formed thereon. The printing element 70b may be constructed of chrome, stainless steel, tool steel and the like. The printing element 70b may also be constructed in part of a resilient or non-resilient material such that the printing element 70b is provided with a resilient or non-resilient surface.

[0092] The printing element 70b of the apparatus 68b utilized in producing the sheet of holographic material 10b in a batch process illustrated in FIG. 8 is a flat plate 72b having a smooth surface 74b. A coating 30b, which is substantially similar to the coating 30 as described hereinbefore, is applied to the smooth surface 74b of the flat plate 72b by a coating assembly 76b, thereby providing a coated surface 78b of the flat plate 72b. The coating assembly 76b is illustrated as a coating brush 80b. However, it should be understood that other methods of applying the coating 30b to the smooth surface 74b of the flat plate 72b may be employed, such as spraying, dipping, and the like.

[0093] The coated surface 78b of the flat plate 72b is then embossed by an embossing element 82b, such as an embossing plate 84b shown in FIG. 9. Embossing of the coated surface 78b of the flat plate 72b provides a holographic image 14b on the coated surface 78b of the flat plate 72b. The holographic image 14b is provided with a first surface 44b and a second surface 46b which is substantially adjacent the smooth surface 74b of the flat plate 72b.

[0094] If the coating 30b used to provide the coated surface 78b of the flat plate 72b is formed of a non-metallic material which does not possess reflective properties necessary to provide the holographic image 14b, a metallic constituent or component (not shown) is applied to the embossed coated surface 78b of the flat plate 72b to provide the holographic image 14b. This process is substantially similar to the metallizing of the embossed coated surface 34 of the cylindrical drum 20 by a metallizing constituent or component 50 to provide the holographic image 10 as illustrated in FIGS. 3 and 5 and described in detail above.

[0095] Once the holographic image 14b has been produced, a bonding material 54b, which is substantially similar to the bonding material 54 as described hereinbefore, may be applied to the holographic image 14b, to the substrate 12b, or both. FIG. 10 illustrates applying the bonding material 54b to the holographic image 14b by a bonding material applicator 86b. It will be understood that other methods of applying the bonding material 54b to the holographic image 14b on the flat plate 72b may be employed, such as spraying, brushing, etc.

[0096] The bonding material 54b applied to the holographic image 14b is contacted with the substrate 12b as

illustrated in FIG. 11, thereby bondingly connecting the holographic image 14b to the substrate 12b and producing the sheet of holographic material 10b.

[0097] To bondingly connect the holographic image 14b to the substrate 12b and to transfer the holographic image 14b from the smooth surface 74b of the flat plate 72b to the substrate 12b, various methods may be employed. For example, heat and/or pressure may be applied to effect the seal between the substrate 12b and the holographic image 14b. As shown in FIG. 11, the holographic image 14b and the substrate 12b may be sandwiched between the flat plate 72b and a sealing plate 88b to effect a seal between the substrate 12b and the holographic image 14b. In addition, the sealing plate 88b may be heated to aid in effecting the seal between the holographic image 14b and the substrate 12b.

[0098] It will be understood that other methods of bondingly connecting and sealing the holographic image 14b and the substrate 12b in the batch process 68b for producing the sheet of holographic material 10b as described herein may be employed.

[0099] FIGS. 10A and 11A depict another method for bondingly connecting and sealing the holographic image 14b to the substrate 12b which utilizes a batch process 68b' for producing the sheet of holographic material 10b. The batch process 68b' is substantially similar to the batch process 68b shown in FIGS. 8-11 and described herein previously, except that the bonding material 54b is applied to the surface 16b of the substrate 12b rather than to the holographic image 14b. The batch process 68b' utilizes a bonding material applicator 86b' for applying the bonding material 54b to the surface 16b of the substrate 12b, wherein the bonding material applicator 86b' is substantially similar to the bonding material applicator 86b described hereinbefore with reference to FIG. 10.

[0100] Shown in FIGS. 10B and 11B is yet another method for bondingly connecting and sealing the holographic image 14b to the substrate 12b which utilizes a batch process 68b'' for producing the sheet of holographic material 10b. The batch process 68b'' is substantially similar to the batch processes 68b and 68b' described hereinbefore with respect to FIGS. 8-11 and 10A-11A, respectively, except that the bonding material 54b is applied to both the surface 16b of the substrate 12b and the first surface 44b of the holographic image 14b. In this manner, a cohesive may be used for the bonding material 54b, allowing for greater control in bondingly connecting the holographic image 14b to the substrate 12b to form the holographic material 10b.

[0101] The batch process 68b'' may be provided with two bonding material applicators 86b'', as shown in FIG. 10B, whereby the bonding material 54b is applied to the substrate 12b and the holographic image 14b simultaneously. Alternatively, the batch process 68b'' may include only one bonding material applicator 86b'' which applies bonding material 54b consecutively to the substrate 12b and the holographic image 14b.

[0102] Referring now to FIG. 12, the sheet of holographic material 10b is then removed from the smooth surface 74b of the flat plate 72b. Methods of removing the sheet of holographic material 10b from the flat plate 72b are known in the art. The sheet of holographic material 10b produced by

the batch process which utilizes the apparatus 68b may be present in different forms such as a roll or sheets of sheet of holographic material 10b.

[0103] Shown in FIG. 12 is a sheet of holographic material 10c which is similar to the sheet of holographic material 10b illustrated in FIG. 7 and described in detail before, except that the holographic image 14c of the sheet of holographic material 10c is produced by engraving rather than embossing. The sheet of holographic material 10c comprises a substrate 12c and a holographic image 14c formed thereon. The sheet of holographic material 10c is produced by a batch process utilizing an apparatus 68c shown in FIGS. 13-16 which is similar to the batch process utilizing the apparatus 68b illustrated in FIGS. 8-11 and described in detail hereinbefore, except that the coated surface 78c of the flat plate 72c is engraved by an engraving element 83c, such as a laser 85c, to produce the holographic image 14c of the sheet of holographic material 10c substantially as shown in FIG. 14, rather than embossed by the embossing element 82b as illustrated in FIG. 9.

[0104] The sheet of holographic material 10c is produced using a printing element 70c which is similar to the printing element 70b shown in FIG. 8 and described in detail hereinabove. The printing element 70c of the apparatus 68c utilized in producing the sheet of holographic material 10c in a batch process illustrated in FIG. 13 is a flat plate 72c having a smooth surface 74c. A coating 30c, which is substantially similar to the coating 30 as described hereinbefore, is applied to the smooth surface 74c of the flat plate 72c by a coating assembly 76c, thereby providing a coated surface 78c of the flat plate 72c. The coating assembly 76c is illustrated as a coating brush 80c. However, it should be understood that other methods of applying the coating 30c to the smooth surface 74c of the flat plate 72c may be employed, such as spraying, dipping, and the like.

[0105] The coated surface 78c of the flat plate 72c is then engraved by an engraving element 83c, such as a laser 85c shown in FIG. 14. Engraving of the coated surface 78c of the flat plate 72c provides a holographic image 14c on the coated surface 78c of the flat plate 72c. The holographic image 14c is provided with a first surface 44c and a second surface 46c which is substantially adjacent the smooth surface 74c of the flat plate 72c.

[0106] If the coating 30c used to provide the coated surface 78c of the flat plate 72c is formed of a non-metallic material which does not possess reflective properties necessary to provide the holographic image 14c, a metallic constituent or component (not shown) is applied to the engraved coated surface 78c of the flat plate 72c to provide the holographic image 14c. This process is substantially similar to the metallizing of the embossed coated surface 34 of the cylindrical drum 20 by a metallizing constituent or component 50 to provide the holographic image 10 as illustrated in FIGS. 3 and 5 and described in detail above.

[0107] Once the holographic image 14c has been produced, a bonding material 54c, which is substantially similar to the bonding material 54 as described hereinbefore, is applied to the holographic image 14c by a bonding material applicator 86c, as shown in FIG. 15. It will be understood that other methods of applying the bonding material 54c to the holographic image 14c on the flat plate 72c may be employed, such as spraying, brushing, etc. The bonding

material **54c** applied to the holographic image **14c** is contacted with the substrate **12c** as illustrated in **FIG. 16**, thereby bondingly connecting the holographic image **14c** to the substrate **12c** and producing the sheet of holographic material **10c**.

[0108] While the bonding material **54c** is depicted as being applied to the holographic image **14c**, it will be understood that the bonding material **54c** may be applied to the substrate **12c** or to both the substrate **12c** and the holographic image **14c**. Application of the bonding material **54c** to the substrate **12c** or to both the holographic image **14c** and the substrate **12c** will be in a substantially similar manner to that described herein previously for application of the bonding material **54b** to the substrate **12b** in the batch process **68b'** described hereinbefore with reference to **FIGS. 10A and 11A**, or for application of the bonding material **54b** to the substrate **12b** and the holographic image **14b** in the batch process **68b"**, as described hereinbefore with reference to **FIGS. 10B and 11B**.

[0109] To bondingly connect the holographic image **14c** to the substrate **12c** and to transfer the holographic image **14c** from the smooth surface **74c** of the flat plate **72c** to the substrate **12c**, various methods may be employed. For example, heat and/or pressure may be applied to effect the seal between the substrate **12c** and the holographic image **14c**. As shown in **FIG. 16**, the holographic image **14c** and the substrate **12c** may be sandwiched between the flat plate **72c** and a sealing plate **88c** to effect a seal between the substrate **12c** and the holographic image **14c**. In addition, the sealing plate **88c** may be heated to aid in effecting the seal between the holographic image **14c** and the substrate **12c**.

[0110] It will be understood that other methods of bondingly connecting and sealing the holographic image **14c** and the substrate **12c** in the batch process which utilizes the apparatus **68c** for producing the sheet of holographic material **10c** as described herein may be employed.

[0111] The sheet of holographic material **10c** is then removed from the smooth surface **74c** of the flat plate **72c**. Methods of removing the sheet of holographic material **10c** from the flat plate **72c** are known in the art. The sheet of holographic material **10c** produced by the batch process which utilizes the apparatus **68c** may be present in different forms such as a roll or sheets of sheet of holographic material **10c**.

The Embodiments of FIGS. 17-18

[0112] Shown in **FIGS. 17-18** is a modified holographic material **10d** provided as a roll **90** of holographic material **10d**. As described in detail herein previously, any of the holographic materials **10** or **10a** produced by a continuous process which utilizes the apparatus **17** or **17a** or the holographic materials **10b** or **10c** produced by a batch process which utilizes the apparatus **68b** or **68c** may be provided as a roll of holographic material. The holographic material **10d** may be withdrawn from the roll **90** and severed or disconnected to provide a sheet of holographic material similar to the sheets of holographic material **10**, **10a**, **10b** and **10c** hereinbefore described with reference to **FIGS. 1, 4, 7** and **12**, respectively, or to provide decorative elements such as decorative grass or glitter, as described in detail hereinafter.

[0113] The roll **90** of holographic material **10d** may be supported on a journal mounted shaft **92**, substantially as shown in **FIGS. 17 and 18**. The holographic material **10d** is withdrawn from the roll **90** via a leading edge **94** until a predetermined length of the holographic material rod has been withdrawn from the roll **90** of holographic material **10d**. In this position, a portion of the holographic material **10d** is disposed under a knife assembly **96** having a plurality of knife edges **97**. The knife assembly **96** is connected to an actuator **98** adapted to move the knife assembly **96** in a first direction **100** and in a second direction **102**. When the predetermined length of holographic material **10d** has been withdrawn from the roll **90** of holographic material **10d**, the actuator **98** moves the knife assembly **96** in the first direction **100** to a position wherein the knife assembly **96** severingly engages the holographic material **10d** to shreddingly cut a plurality of elongated strips **101** of the holographic material **10d** from the roll **90** of holographic material **10d**.

[0114] In another optional mode, the actuator **98** may then turn the knife assembly **96** to the second direction **102** wherein the knife assembly **96** severingly re-engages the plurality of elongated strips **101** of holographic material **10d**, thereby causing the elongated strips **101** of the holographic material **10d** to be severed into segments of decorative grass **103** (**FIG. 17**) or into small pieces **104** (**FIG. 18**), for use as glitter, confetti, tinsel, decorative flakes, decals, labels, stickers, sequins, icicles for Christmas trees, imitation snow and the like (it will be appreciated that this process is represented schematically in the drawings). The actuator **98** may comprise a hydraulic or pneumatic cylinder or a motor and gear arrangement or any other form of arrangement suitable for moving the knife assembly **96** in the directions **100** and **102**. After the knife assembly **96** has cuttingly severed the desired portion of holographic material **10d** from the roll **90** of the holographic material **10d**, the actuator **98** moves the knife assembly **96** in a direction **106** to a storage position disposed a distance above the holographic material **10d**. Alternatively, the leading edge **94** of the holographic material **10d** may be run across a first knife assembly **96** set in the surface (not shown) to form the elongated strips **101** of holographic material **10d**, wherein the actuator **98** actuates a second knife edge (not shown) to cross-cut the elongated strips **101** of holographic material **10d** into segments of decorative grass **103** or small pieces **104** for use as glitter, confetti, tinsel and the like. Apparatus and methods for making decorative shredded materials and the like are disclosed in U.S. Pat. No. 4,646,388, entitled "APPARATUS FOR PRODUCING WEIGHED CHARGES OF LOOSELY AGGREGATED FILAMENTARY MATERIAL", issued to Weder et al on Mar. 3, 1987, which is hereby expressly incorporated by reference herein. However, it will be understood that while the primary uses of the segments of grass **103** and the small pieces **104** of holographic material **10d** are for decorative purposes, the segments of grass **103** and small pieces **104** of holographic material **10d** may also be used for purposes other than decorative purposes, such as but not by way of limitation, uses for scattering light for camouflage or scattering radar beams, as well as for producing sunscreens, pigments, paints, inks and adhesives.

[0115] It will be appreciated that the holographic material **10d** may be a laminate formed by laminating a sheet of material such as a transparent polymeric film to either surface of a holographic material, such as one of the

holographic materials **10-10c** produced as described in detail herein before. The transparent polymeric film of the holographic material **10d** increases the thickness of the holographic material **10d** while still maintaining visual display of the holographic image **14d**, and thus the grass **103** or small pieces **104** of the holographic material **10d** produced upon cutting the holographic material **10d** will have a larger volume at substantially less cost than the grass **103** or small pieces **104** produced from the holographic material **10d** which is not a laminate containing the transparent polymeric film. In addition, barrier properties, heat resistant properties and other desirable properties can be provided to the holographic material **10d** by lamination of different types of sheets of material to the holographic material to provide the holographic material **10d**.

Embodiments of FIGS. 19-21

[0116] As noted previously, the sheet of holographic material **10** may be used to wrap a floral grouping **110**. "Floral grouping" as used herein will be understood to include cut fresh flowers, artificial flowers, a single flower, other fresh and/or artificial plants or other floral materials and may include other secondary plants and/or ornamentation or artificial or natural materials which add to the aesthetics of the overall floral arrangement. The floral grouping **110** comprises a bloom or foliage portion **112** and a stem portion **114**. The term "floral grouping" may be used interchangeably herein with the term "floral arrangement".

[0117] In a method of use, a modified sheet of holographic material **10e** is provided, which is similar to the sheet of holographic material **10** shown in **FIG. 1** and described in detail previously, except as described below. The sheet of holographic material **10e** has an upper surface **116**, a lower surface **118**, a first side **120**, a second side **122**, and third side **124** and a fourth side **126**. A strip of bonding material **128** is disposed on the upper surface **116** and near the first side **120** of the sheet of holographic material **10e**, the strip of bonding material **128** extending between the third and fourth sides **124** and **126**, respectively, of the sheet of holographic material **10e**.

[0118] The floral grouping **110** having the bloom portion **112** and the stem portion **114** (**FIG. 19**) is disposed on the upper surface **116** of the sheet of holographic material **10e**. The sheet of holographic material **10e** is then wrapped about the floral grouping **110** by taking the second side **122** of the sheet of holographic material **10e** and rolling the sheet of holographic material **10e** in a direction **130** about the floral grouping **110** (**FIG. 20**). The sheet of holographic material **10e** is continued to be rolled about the floral grouping **110** until a portion of the bonding material **128** is disposed adjacent a portion of the lower surface **118** of the sheet of holographic material **10e** and brought into bonding contact or engagement therewith (**FIG. 21**), thereby bondingly connecting the bonding material **128** on the upper surface **116** of the sheet of holographic material **10e** to a portion of the lower surface **118** of the sheet of holographic material **10e** for cooperating to secure the sheet of holographic material **10e** in a wrapped condition about the floral grouping **110** to provide a wrapper **132** wrapped about the floral grouping **110**, as shown in **FIG. 21**.

[0119] In the wrapped condition with the sheet of holographic material **10e** wrapped about the floral grouping **110**

as shown in **FIG. 21**, the wrapper **132** forms a conical shape with an open upper end **134** and an open lower end **136**. The wrapper **132** covers a portion of the bloom portion **112** of the floral grouping **110**. A portion of the stem portion **114** of the floral grouping **110** extends through the open lower end **136** of the wrapper **132**. The wrapper **132** is tightly wrapped about the stem portion **114** of the floral grouping **110**. The bonding material **128** on the sheet of holographic material **10e** may contact and engage some of the stem portion **114** of the floral grouping **110** to cooperate in securing the wrapper **132** so that the wrapper **132** is tightly wrapped about the stem portion **114** of the floral grouping **110** and to prevent the floral grouping **110** from slipping or moving within the wrapper **132**.

[0120] At least a portion of the floral grouping **110** is disposed within the wrapper **132**. In some applications, the stem portion **114** of the floral grouping **110** extends through the open lower end **136** of the wrapper **132**, as described before. In other applications, the stem portion **114** of the floral grouping **110** does not extend through the open lower end **136** of the wrapper **132**. In some applications, the wrapper **132** is tightly wrapped about the stem portion **114** of the floral grouping **110**. The bloom portion **112** of the floral grouping **110** is disposed adjacent or above the open upper end **134** of the wrapper **132** and the bloom portion **112** of the floral grouping **110** is visible via the open upper end **134** of the wrapper **132**. In some instances, the bloom portion **112** of the floral grouping **110** may extend beyond the open upper end **134** of the wrapper **132**. In some applications, the upper end **134** of the wrapper **132** may be closed is desired. In some applications, the lower end **136** of the wrapper **132** may be closed if desired.

[0121] The wrapper **132**, as shown in **FIG. 21**, is generally conically shaped. The sheet of sheet of holographic material **10e** may also be wrapped about the floral grouping **110** to form a cylindrically shaped wrapper **132a** having an open upper end **134a** and an open lower end **136a** substantially as shown in **FIG. 22**, or any other shape wrapper if desired in a particular application.

[0122] U.S. Pat. No. 5,181,364, entitled "WRAPPING A FLORAL GROUPING WITH SHEETS HAVING AN ADHESIVE OR COHESIVE MATERIAL APPLIED THERETO", issued to Weder et al on Jan. 26, 1993, which has been incorporated by reference herein above, discloses methods of wrapping a floral grouping in a cylindrically-shaped wrapper.

Embodiments of FIGS. 23-28

[0123] As noted above, a sheet of holographic material **10f** may be used to provide a decorative cover **140** for an object such as a flower pot **142** or a potted plant **144**. The term "flower pot" refers to any type of container used for holding a floral grouping or a plant. Examples of flower pots used in accordance with the present invention are clay pots, plastic pots, wooden pots, pots made from natural and/or synthetic fibers, and the like.

[0124] The flower pot **142** has an open upper end **146**, a closed lower end **148**, and an outer peripheral surface **150**. An opening **152** intersects the open upper end **146** forming an inner peripheral surface **154** and a retaining space **156**. A plant **158** and growing medium **160** (shown in **FIG. 28**) may be disposed in the flower pot **142**, thereby forming the potted plant **144**.

[0125] To form the sheet of holographic material **10f** into the decorative cover **140** about the outer peripheral surface **150** of the flower pot **142**, both the flower pot **142** and the sheet of holographic material **10f** are provided. The sheet of holographic material **10f** is desirably formed of a flexible yet shape-sustaining material. The flower pot **142** is disposed upon the upper surface **116f** of the sheet of holographic material **10f** so that the closed lower end **148** of the flower pot **142** is disposed substantially adjacent a portion of the upper surface **116f** of the sheet of holographic material **10f**. To cover the object, the sheet of holographic material **10f** may be manually or automatically formed about the outer peripheral surface **150** of the flower pot **142** or potted plant **144**.

[0126] In one embodiment of a manual application of wrapping the sheet of holographic material **10f** about the flower pot **142** to provide the decorative cover **140** for the flower pot **142**, the sheet of holographic material **10f** is wrapped about the outer peripheral surface **150** of the flower pot **142** so that the upper surface **116f** of the sheet of holographic material **10f** is disposed substantially adjacent the outer peripheral surface **150** of the flower pot **142** (FIGS. 24 and 25) to form the decorative cover **140** about the flower pot **142** wherein the holographic image **14f** of the sheet of holographic material **10f** is visible and thereby provides the desired holographic effect to the decorative cover **140** (FIG. 25). That is, the lower surface **118f** of the sheet of holographic material **10f** becomes an outer surface **164** of the decorative cover **140** and at least a portion of the holographic design **14f** constitutes at least a portion of the decor of the decorative cover **140**. Methods of manually wrapping a material about a flower pot are known to those having ordinary skill in the art.

[0127] The decorative cover **140** comprises a base portion **172** and a skirt portion **174**. The base portion **172** of the decorative cover **140** is dimensioned to encompass at least a portion of the outer peripheral surface **150** of the flower pot **142** such that the open upper end **146** of the flower pot **142** remains substantially uncovered by the decorative cover **140**, and the skirt portion **174** of the decorative cover **140** extends outwardly from the base portion **172** of the decorative cover **140**.

[0128] Another method for forming the decorative cover **140** about a flower pot **142** using the sheet of sheet of holographic material **10f** is disclosed in U.S. Pat. No. 4,733,521, entitled "COVER FORMING APPARATUS", issued to Weder et al on Mar. 29, 1988, which is hereby expressly incorporated herein by reference.

[0129] The decorative cover **140** formed by wrapping the sheet of holographic material **10f** about the flower pot **142** may be secured to the outer peripheral surface **150** of the flower pot **142** by the use of one or more bonding materials described herein. A bonding material **161**, such as a pressure sensitive adhesive, may be disposed on the upper surface **116f** of the sheet of holographic material **10f** to secure the decorative cover **140** about the outer peripheral surface **150** of the flower pot **142**. In such instance, a portion of the overlapping folds **163** formed in the decorative cover **140** may be connected via the bonding material **161** and a portion of the overlapping folds **163** may remain unconnected.

[0130] Alternatively, the sheet of holographic material **10f** may be constructed of a shape-sustaining material such that

no bonding material is required to form the decorative cover **140**. Upon wrapping the shape-sustaining sheet of holographic material **10f** about the outer peripheral surface **150** of the flower pot **142** to form the decorative cover **140**, the plurality of overlapping folds **163** formed therein are dead folds. The term "dead folds" as used herein is understood to mean the formation of pleats wherein the pleats are unsecured (i.e., not bondingly connected) but maintain their pleated configuration, such as when one folds metal foil.

[0131] Another method of securing the decorative cover **140** to the flower pot **142** is by applying a band (not shown) about the decorative cover **140** and the flower pot **142** to hold the decorative cover **140** in place about the flower pot **142** such as is described in U.S. Pat. No. 5,115,599, entitled "MEANS FOR SECURING A DECORATIVE COVER ABOUT A FLOWER POT", issued to Weder on Apr. 21, 1992 and which is hereby expressly incorporated herein by reference.

[0132] The term "band" when used herein refers to any material which may be secured about an object such as a flower pot, such bands commonly being referred to as elastic bands, rubber bands or non-elastic bands and also includes any other type of material such as an elastic or non-elastic string, elastic or non-elastic piece of material, a round piece of material, a flat piece of material, a ribbon, a piece of paper strip, a piece of plastic strip, a piece of wire, a tie wrap or a twist tie or combinations thereof or any other device capable of gathering the holographic material to removably or substantially permanently form a crimped portion and secure the crimped portion formed in the holographic material which may be secured about an object such as the flower pot. The band may also include a bow if desired in a particular application.

[0133] Once the decorative cover **140** is constructed by wrapping the sheet of holographic material **10f** about a flower pot **142** and the decorative cover **140** is secured to the flower pot **142**, growing medium **160** and a plant **158** may be disposed in the flower pot **142** to which the decorative cover **140** is secured, thereby resulting in a decoratively cover potted plant **170** as shown in FIG. 28.

[0134] Alternatively, the sheet of holographic material **10f** may be formed into a preformed decorative cover **162** (FIG. 26) which is then placed about the outer peripheral surface **150** of the flower pot **142** or potted plant **144**. The preformed decorative cover **162** has an opening **166** and comprises a base portion **176** and a skirt portion **178**. The base portion **176** of the preformed decorative cover **162** is dimensioned to encompass at least a portion of the outer peripheral surface **150** of the flower pot **142** when the flower pot **142** is disposed in the preformed decorative cover **162**. The skirt portion **178** of the preformed decorative cover **162** extends outwardly from the base portion **176** of the preformed decorative cover **140**. The preformed decorative cover **162** is self-supporting by virtue of overlapping folds **168** wherein at least a portion of the overlapping folds **168** are bonded together, thereby providing structural integrity to the preformed decorative cover **162**. The holographic design **14f** of the sheet of holographic material **10f** provides at least a portion of the decor of the preformed decorative cover **162**.

[0135] The preformed decorative cover **162** may be formed using a conventional mold system **165** comprising a male mold **167** and a female mold **169** having a mold cavity

171 for matingly receiving the male mold **167** (FIG. 27). The sheet of holographic material **10f** is positioned between the male and female molds **165** and **167**, respectively. Movement of the male mold **167** in the direction **173** and into the mold cavity **171** of the female mold **169** forces the sheet of holographic material **10f** to be disposed about the portion of the male mold **167** disposed in the mold cavity **171** of the female mold **169** and thereby forms the sheet of holographic material **10f** into the preformed decorative cover **162** (FIGS. 26 and 27). The preformed decorative cover **162**, which may be constructed from the materials described herein above, may have a bonding material disposed upon a portion thereof.

[0136] Methods for forming such preformed decorative pot covers are well known in the art. One method for forming such a preformed plant cover or pot cover is shown in U.S. Pat. No. 4,773,182 entitled "ARTICLE FORMING SYSTEM", issued to Weder et al on Sep. 27, 1988, which is hereby expressly incorporated herein by reference. Another method for forming such covers is described in U.S. Pat. No. 5,291,721 entitled "COVER FORMING APPARATUS HAVING PIVOTING FORMING MEMBERS", issued to Weder et al on Mar. 8, 1994, which is expressly incorporated herein by reference.

[0137] A potted plant **144** can be disposed in the opening **166** of the preformed decorative cover **162** such that the open upper end **146** of the flower pot **142** remains substantially uncovered by the preformed decorative cover **162**, thereby also resulting in a decoratively covered potted plant **170** as shown in FIG. 28.

[0138] The term "potted plant" as used herein refers to a plant having a bloom or foliage portion, a stem portion and a root portion, the root portion being disposed in a growing medium. The term "potted plant" as used herein also includes botanical items and propagules.

[0139] The term "botanical item" when used herein refers to a natural or artificial herbaceous or woody plant, taken singly or in combination. The term "botanical item" also refers to any portion or portions of natural or artificial herbaceous or woody plants including stems, leaves, flowers, blossoms, buds, blooms, cones or roots, taken singly or in combination, or in groupings of such portions such as a bouquet or a floral grouping.

[0140] The term "propagule" when used herein refers to any structure capable of being propagated or acting as an agent of reproduction including seeds, shoots, stems, runners, tubers, plants, leaves, roots or spores.

[0141] The term "growing medium" when used herein refers to any liquid, solid or gaseous material used for plant growth or for the cultivation of propagules, including organic and inorganic materials such as soil, humus, perlite, vermiculite, sand, water, and including the nutrients, fertilizers or hormones or combinations thereof required by the plants or propagules for growth.

Embodiments of FIGS. 29-35

[0142] Shown in FIGS. 29-32 and designated therein by the general reference numeral **180** is a wrapper for a floral grouping **110** constructed from a holographic material **10g** which is substantially similar to the holographic material **10** shown in FIG. 1 and described in detail herein previously.

The wrapper **180** comprises a sleeve **182**, which is generally tubular in shape, and the floral grouping **110**. The sleeve **182**, as illustrated in FIG. 29, has a first end **184**, a second end **186**, an outer peripheral surface **188** and an opening **190** intersecting both the first end **184** and the second end **186**, forming an inner peripheral surface **192** and providing a retaining space **194** therein. The holographic design **14g** of the holographic material **10g** is visible on the outer peripheral surface **188** of the sleeve **182**. It should be noted that the second end **186** of the sleeve **182** may be closed, forming a closed second end, in which case the opening **190** only intersects the first end **184** of the sleeve **182**. Sleeves and their construction are well known in the art, and sleeves are commercially available, as are various devices and mechanisms capable of forming sleeves.

[0143] The sleeve **182** is adapted to receive a floral grouping **110** within the retaining space **194** thereof. The floral grouping **110** (FIG. 30) may be disposed in the opening **190** in the sleeve **182** and contained substantially in the retaining space **194** of the sleeve **182**, thereby forming the wrapper **180**, as will be described in detail below.

[0144] A bonding material **196** may be disposed on at least a portion of the inner peripheral surface **192** of the sleeve **182** (FIG. 31), or alternatively, the bonding material **196** may be disposed on the outer peripheral surface **188** of the sleeve **182** as illustrated in FIG. 32, or in a further alternative, the bonding material **196** may be disposed on both the inner peripheral surface **192** and the outer peripheral surface **188** of the sleeve **182** (not shown).

[0145] The bonding material **196** may further comprise a color, or a combination of colors, as previously described herein. Further, the bonding material **196** may comprise at least a portion of a design on the sleeve **182**. The term "design" as used herein is defined as any geometric form, or any combination of geometric forms, for example, squares, round spots, triangles, rectangles, octagonals, or the like (not shown). The term "design" is further defined as any non-geometric, asymmetrical or fanciful forms, or any combination thereof, for example, but not by way of limitation, hearts, balloons, flowers, lace, slogans, logos, print (any combination of letters, numbers and/or symbols), signs, human forms (real and fictional), animal forms (real and fictional), cartoon characters, and/or plant forms.

[0146] Such a design may comprise a color or a portion of a color or any combination of colors. Alternatively, at least a portion of the design may be colorless, translucent, transparent, opaque, pearlescent, iridescent, or the like.

[0147] However, it will be understood that the sleeve **182** may not be provided with a bonding material disposed thereon, and other methods and devices, such as a band, may be employed to secure the sleeve **182** about the floral grouping **110** to form the wrapper **180**. Such bands and methods of use thereof have been described in detail hereinbefore.

[0148] The sleeve **182** is generally tubularly shaped, but the sleeve **182** may be, by way of example only, cylindrical, conical, frusto-conical, or a combination of both frusto-conical and cylindrical (not shown). Further, as long as the sleeve **182** is capable of receiving a floral grouping **110**, any shape of sleeve **182**, whether geometric, non-geometric, asymmetrical and/or fanciful, may be utilized.

[0149] In a general method of use, illustrated in FIGS. 30-32, at least a portion of the floral grouping 110 is disposed within the sleeve 182. In some applications, the stem portion 114 of the floral grouping 110 extends into the sleeve 182 via the open first end 184 of the sleeve 182, extending through and beyond the open second end 186 of the sleeve 182. The bloom portion 112 of the floral grouping 110 is therefore disposed adjacent the open first end 184 of the sleeve 182 and the bloom portion 112 of the floral grouping 110 is visible via the open first end 184 of the sleeve 182 (FIGS. 30-32). In some instances, the bloom portion 114 of the floral grouping 110 may extend above the open first end 184 of the sleeve 182. In some applications, the first end 184 of the sleeve 182 may be closed if desired (not shown). In some circumstances, the second end 186 of the sleeve 182 may be closed if desired (not shown).

[0150] In one method of use (FIGS. 30-32), an operator provides the sleeve 182 (FIG. 29), and the floral grouping 110 (FIG. 30). The operator then disposes the floral grouping 110 into the sleeve 182 by opening the sleeve 182 at the first end 184 and disposing the floral grouping 110 into the opening 190 in the sleeve 182 and the retaining space 194 of the sleeve 182 by inserting first the stem portion 114 of the floral grouping 110 into the retaining space 194 of the sleeve 182 via the opening 190 intersecting the first end 184 of the sleeve 182, in a manner which permits a portion of the stem portion 114 of the floral grouping 110 to be disposed in the retaining space 194 adjacent the second end 186 of the sleeve 182, the second end 186 generally having the narrowest diameter. By inserting the floral grouping 110 into the sleeve 182 in this manner, the bloom portion 112 of the floral grouping 110 is also disposed in the retaining space 194 of the sleeve 182 and the bloom portion 112 of the floral grouping 110 is disposed substantially adjacent the first end 184 of the sleeve 182, the first end 184 generally having the widest diameter. In this method, at least a portion of the stem portion 114 of the floral grouping 110 extends slightly beyond the second end 186 of the sleeve 182, and the bloom portion 112 of the floral grouping 110 is clearly visible at the open first end 184 of the sleeve 182.

[0151] The sleeve 182 may then be crimped about the floral grouping 110 as shown in FIGS. 31-32. The crimping operation is conducted by an operator after the floral grouping 110 is disposed in the sleeve 182 by crimping at least a portion of the sleeve 182 in the area of the stem portion 114 of the floral grouping 110, wherein the bonding material 196 retains the sleeve 182 in the crimped condition. Such crimping may be conducted by hand, by grasping and substantially encompassing with one or more hands the second end 186 of the sleeve 182 in the area of the bonding material 196 and evenly and firmly squeezing that portion of the sleeve 182 about the area having the bonding material 196, thereby pressing and gathering both the sleeve 182 and the bonding material 196 against itself and about the stem portion 114 of the floral grouping 110. The sleeve 182 may also be crimped by using both a crimping motion (as described above) and a turning motion to create a twisted crimping, resulting in a sleeve 182 which is both crimped as previously described, and which is twisted about at least a portion of the stem portion 114 of the floral grouping 110, the sleeve 182 adjacent the stem portion 114 of the floral grouping 110 being rotated about the stem portion 114 of the floral

grouping 110, for example but not by way of limitation, between about one-eighth of a turn to about a full turn (not shown).

[0152] When the sleeve 182 is crimped, a plurality of overlapping folds 198 are formed in the crimped area. The plurality of overlapping folds 198 (only one overlapping fold designated by the reference numeral 198 in FIGS. 31 and 32) resulting from the gathered, crimped material of the sleeve 182 may be connected, that is, all of the overlapping portions of the sleeve 182 are bondingly connected together via the bonding material 196. A plurality of overlapping folds 198 may be formed by hand, during crimping, or by mechanical methods and devices. Such mechanical methods and devices are disclosed generally in "ARTICLE FORMING SYSTEM", which has previously been incorporated by reference herein. Alternatively, the crimping may be conducted in a manner in which not all of the plurality of overlapping folds 198 are bondingly connected together. It will be appreciated that the plurality of overlapping folds 198 (connected or unconnected) are formed primarily in the crimped area. Such crimping as described above may also be conducted by any device or mechanism known in the art and used for gathering or crimping materials.

[0153] Alternatively, the sleeve 182 may remain uncrimped. The bonding material 196 disposed upon the sleeve 182 may cause the sleeve 182 to bondingly connect to portions of itself, causing the sleeve 182 to conform, either generally or closely (depending, as will be appreciated, upon the amount of bonding material 196 and the amount of holographic material 10g of the sleeve 182 which overlaps and connects to itself) to the floral grouping 110.

[0154] When the floral grouping 110 is disposed in the sleeve 182 by any method described herein, or known in the art, the sleeve 182 substantially surrounds and encompasses a substantial portion of the floral grouping 110. When the sleeve 182 is disposed about the floral grouping 110, the sleeve 182 forms a wrapper 180 which provides a decorative packaging for the floral grouping 110 contained therein.

[0155] It will be appreciated that the sleeve 182 has sufficient flexibility but also sufficient rigidity to both remain in and sustain its general shape, thereby substantially surrounding and encompassing the floral grouping 110.

[0156] Illustrated in FIGS. 33-35 is a decorative cover 140a for a flower pot 142 which is constructed from a sheet of holographic material 10g. The decorative cover 140a is substantially similar in construction to the decorative cover 140 previously described herein with the exceptions hereinafter described. The decorative cover 140a comprises a sleeve 182a, which is substantially similar to the sleeve 182 illustrated in FIG. 29, and may extend over the outer peripheral surface 150 of the flower pot 142. The sleeve 182a includes an upper portion 200 and a lower portion 202. The lower portion 202 of the sleeve 182a is sized to closely surround and encompass a flower pot 142 disposed within the sleeve 182a, while the upper portion 200 of the sleeve 182a extends upwardly from the flower pot 142 disposed in the sleeve 182a. The upper portion 200 of the sleeve 182a is detachable from the lower portion 202 of the sleeve 182a via vertical perforations 204 and/or circumferential perforations 206 which extend about the sleeve 182a adjacent to or above the open upper end 146 of the flower pot 142, as illustrated in FIGS. 33-35, thereby forming a decorative

flower pot cover **208** having a holographic image **14g** thereon. The holographic design **14g** of the holographic material **10g** is visible on at least a portion of the lower portion **202** of the sleeve **182a**, and the holographic design **14g** of the holographic material **10g** may be visible on at least a portion of both the upper and lower portions **200** and **202**, respectively, of the sleeve **182a**.

[**0157**] In one method of use, the flower pot **142** having growing medium **160** and a floral grouping **110** or a plant **158** disposed therein is disposed in the sleeve **182a** such that the lower portion **202** of the sleeve **182a** is positioned substantially adjacent the outer peripheral surface **150** of the flower pot **142** and the upper portion **200** of the sleeve **182a** extends upwardly from the flower pot **142**. In this manner, the upper portion **200** of the sleeve **182a** substantially surrounds and encompasses at least a portion of the floral grouping **110** or plant **158** disposed in the flower pot **142**.

[**0158**] The sleeve **182a** may have a bonding material (not shown) disposed thereupon such that the second end **186a** of the sleeve **182a** can be connected to the flower pot **142**. Alternatively, a bonding material may be disposed upon the outer peripheral surface **150** of the flower pot **142**. In a further alternative, the bonding material may be disposed on both the flower pot **142** and the sleeve **182a** (not shown).

[**0159**] Alternatively, the sleeve **182a** may extend over a flower pot **142** already covered by a decorative cover such as the decorative covers **140** or **162** (FIGS. **25** and **26**), the sleeve **182a** often being torn away from the decorative cover **140** or **162** after shipment and delivery (not shown).

[**0160**] It will be appreciated that the method of disposing the flower pot **142** into the sleeve **182a** is generally substantially similar to the method described above for disposing the floral grouping **110** into the sleeve **182**.

Embodiment of FIG. 36

[**0161**] Shown in FIG. **36** and designated therein by the general reference numeral **210** is a wrapper for a floral grouping **212** comprising a sleeve **182b** and a floral grouping **212**, the sleeve **182b** being constructed from the holographic material **10g** and being substantially similar to the sleeve **182** as shown in FIGS. **29-32** and described in detail herein previously. The wrapper **210** is similar to the wrapper **180** above, except that the wrapper **210** is a narrow tubular shape which is constructed to accommodate a floral grouping **212** comprising generally only a single bloom **214** and stem **216**. The holographic design **14g** of the holographic material **10g** is visible on at least a portion of the sleeve **182b**, thereby providing the wrapper **210** with a holographic effect.

[**0162**] The method of use of the wrapper **210** is similar to the method of use of the wrapper **180** shown in FIGS. **29-32** and described in detail herein above.

[**0163**] For the sake of brevity, only the use of holographic materials similar to the holographic material **10** for providing decorative covers and wrappers for floral groupings such as cut flowers and potted plants have been described herein. However, it will be understood that holographic materials similar to the holographic materials **10a-10d** may be used in the same manner. In addition, while several uses of the holographic materials **10-10d** have been disclosed herein, other products which can be produced from the holographic materials of the present invention include sunglasses, sun

visors, controlled spectrum lighting, decorative functional boxes and bags, ornaments, window decorations, clothing, signs, highway markings, anti-counterfeiting and copying devices, toys and toy enhancements, heat shielding, radiation shielding, spectrum-modifying glazing and other spectrum-modifying devices, protective coverings for solar cells, insulating material for buildings, refrigerators and freezers, and other insulating needs, greenhouse and terrarium films, UV blocking materials, and photographic and light filters.

[**0164**] From the above description, it is clear that the present invention is well adapted to carry out the objects and to attain the advantages mentioned herein as well as those inherent in the invention. While presently preferred embodiments of the invention have been described for purposes of this disclosure, it will be understood that numerous changes may be made which will readily suggest themselves to those skilled in the art and which are accomplished within the spirit of the invention disclosed and as defined in the appended claims.

What is claimed is:

1. A batch process for applying a holographic image to a substrate to produce a holographic material, the process comprising:

providing a printing element having a polished surface;
applying a coating capable of receiving a holographic image to the polished surface of the printing element to provide a coated surface;

engraving the coated surface to provide a holographic image thereon, the holographic image having a first surface and a second surface wherein the second surface of the holographic image is disposed substantially adjacent the polished surface of the printing element;

providing a substrate;

applying a bonding material to at least one of the substrate and the first surface of the holographic image; and

disposing the substrate adjacent the first surface of the holographic image containing the bonding material so as to bondingly connect the holographic image to the substrate, thereby producing the holographic material and thus removing the holographic material from the polished surface of the printing element.

2. The batch process of claim 1 wherein, in the step of providing a printing element, the printing element is selected from the group consisting of a flat plate and a platen press.

3. The batch process of claim 2 wherein, in the step of providing a printing element, the printing element is constructed of a material selected from the group consisting of chrome, stainless steel and tool steel.

4. The batch process of claim 2 wherein, in the step of providing a printing element, the surface of the printing element is resilient.

5. The batch process of claim 2 wherein, in the step of providing a printing element, the surface of the printing element is non-resilient.

6. The batch process of claim 1 wherein, in the step of applying a coating, the coating is selected from the group consisting of metallic polymeric film, nonmetallic polymer film, foil, metallized lacquer, non-metallized lacquer, iridescent film, ink containing metallized glitter mixed with a lacquer, and combinations thereof.

7. The batch process of claim 1 wherein, in the step of providing a substrate, the substrate is constructed of a material selected from the group consisting of polymeric film, foil, paper, tissue, laminates thereof and combinations thereof.

8. The batch process of claim 7 wherein the substrate has a substantially rough, textured surface.

9. The batch process of claim 7 wherein the substrate has a smooth surface.

10. A batch process for applying a holographic image to a substrate to produce a holographic material, the batch process comprising:

providing a printing element having a polished surface;

applying a coating capable of receiving a holographic image to the polished surface of the printing element to provide a coated surface;

engraving the coated surface to provide an image on the coating;

applying a metallic constituent or component to the image to provide a holographic image having a first surface and a second surface wherein the second surface of the holographic image is disposed substantially adjacent the polished surface of the printing element;

providing a substrate;

applying a bonding material to at least one of the substrate and the first surface of the holographic image; and

disposing the substrate adjacent the first surface of the holographic image containing the bonding material so

as to bondingly connect the holographic image to the substrate, thereby producing the holographic material and thus removing the holographic material from the polished surface of the printing element.

11. The batch process of claim 10 wherein, in the step of providing a printing element, the printing element is selected from the group consisting of a flat plate and a platen press.

12. The batch process of claim 11 wherein, in the step of providing a printing element, the printing element is constructed of a material selected from the group consisting of chrome, stainless steel and tool steel.

13. The batch process of claim 11 wherein, in the step of providing a printing element, the surface of the printing element is resilient.

14. The batch process of claim 11 wherein, in the step of providing a printing element, the surface of the printing element is non-resilient.

15. The batch process of claim 10 wherein, in the step of applying a coating, the coating is selected from the group consisting of polymeric film, foil, lacquer and combinations thereof.

16. The batch process of claim 10 wherein, in the step of providing a substrate, the substrate is selected from the group consisting of polymeric film, foil, paper, tissue, laminates thereof and combinations thereof.

17. The batch process of claim 16 wherein the substrate has a substantially rough, textured surface.

18. The batch process of claim 16 wherein the substrate has a smooth surface.

* * * * *