



(12) **United States Design Patent**
Mahe et al.

(10) **Patent No.:** **US D930,058 S**
(45) **Date of Patent:** **** Sep. 7, 2021**

(54) PET ROBOT	6,428,432 B1 *	8/2002	Kachel	A63B 43/06	473/570
(71) Applicant: FUZHI TECHNOLOGY	D465,733 S *	11/2002	Hill		D9/519
(SHENZHEN) CO., LTD, Shenzhen	D473,984 S *	4/2003	Stephens		D32/21
(CN)	D474,312 S *	5/2003	Stephens		D32/21
(72) Inventors: Yingsheng Mahe, Shenzhen (CN);	D478,813 S *	8/2003	Beene		D9/519
Jialin Li, Shenzhen (CN); Dongdu	D547,430 S *	7/2007	Low		D21/713
Song, Shenzhen (CN); Hong Zhu,	D564,900 S *	3/2008	Green		D9/504
Shenzhen (CN)	D567,673 S *	4/2008	Chu		D10/15
(73) Assignee: FUZHI TECHNOLOGY	D582,281 S *	12/2008	Zanaletti		D9/516
(SHENZHEN) CO., LTD, Shenzhen	D596,306 S *	7/2009	Levine		D24/214
(CN)	D612,245 S *	3/2010	Canamasas Puigbo		D9/519
(**) Term: 15 Years	D731,180 S *	6/2015	Neuhaus		D3/273
	D758,557 S *	6/2016	Jih		D23/355
	D777,847 S *	1/2017	Rost		D21/680
	D810,166 S *	2/2018	Lee		D15/199
	D824,460 S *	7/2018	Wang		D21/578
	D832,326 S *	10/2018	Lee		A63H 5/00
					D15/199

(Continued)

Primary Examiner — Patricia A Palasik

(21) Appl. No.: **29/721,281**

(22) Filed: **Jan. 20, 2020**

(30) **Foreign Application Priority Data**

Sep. 20, 2019 (CN) 201930519183.1

(51) **LOC (13) Cl.** **15-09**

(52) **U.S. Cl.**
USPC **D15/199**

(58) **Field of Classification Search**
USPC D15/199; D21/578–583, 621, 622;
D32/21; D34/34
CPC B25J 5/007; B25J 11/00; B25J 11/008;
B62D 57/024; G06N 3/008; Y10S 901/01
See application file for complete search history.

(56) **References Cited**

U.S. PATENT DOCUMENTS

D324,106 S *	2/1992	Greenblatt	D24/200
D420,403 S *	2/2000	Bart	D21/398
6,368,176 B1 *	4/2002	Lozowski	A63H 5/00
			446/169

(57) **CLAIM**

The ornamental design for a pet robot, as shown and described.

DESCRIPTION

FIG. 1 is a first perspective view of an embodiment of a pet robot shown our design;
FIG. 2 is a second perspective view of the embodiment of the pet robot shown our design;
FIG. 3 is a front elevation view thereof;
FIG. 4 is a rear elevation view thereof;
FIG. 5 is a left side elevation view thereof;
FIG. 6 is a right side elevation view thereof;
FIG. 7 is a top plan view thereof; and,
FIG. 8 is a bottom plan view thereof.
The broken lines shown in the drawings are included for the purpose of illustrating portions of the article that form no part of the claimed design.

1 Claim, 8 Drawing Sheets

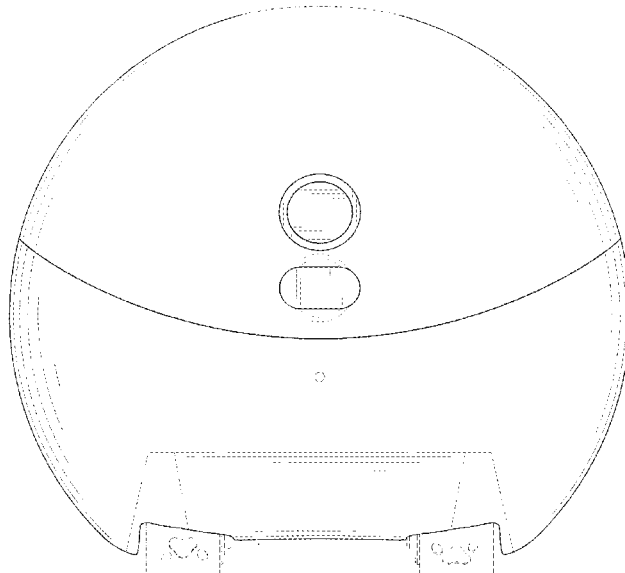

(56)

References Cited

U.S. PATENT DOCUMENTS

D832,327 S * 10/2018 Miao A63H 33/18
D15/199
D843,498 S * 3/2019 Clerc A63H 33/26
D21/578
D855,094 S * 7/2019 Li D15/199
10,399,616 B2 * 9/2019 Ellerman A63H 33/26
D866,553 S * 11/2019 Miura D14/388
D872,384 S * 1/2020 Crane D30/160
D881,886 S * 4/2020 Bidwell D14/420
D910,728 S * 2/2021 Chung D15/199
D910,729 S * 2/2021 Chung D15/199
D912,114 S * 3/2021 Reichert D15/199
2004/0253904 A1 * 12/2004 Lin A63B 23/12
446/236
2005/0043125 A1 * 2/2005 Nakano A63H 33/18
473/571
2015/0224640 A1 * 8/2015 Vu B25J 5/007
700/259
2018/0024561 A1 * 1/2018 Soh G05D 1/0272
700/258
2018/0043838 A1 * 2/2018 Ellerman A63H 33/26
2019/0009181 A1 * 1/2019 Kroyan B25J 9/1697
D21/578
2019/0061161 A1 * 2/2019 Higuchi G05D 1/0255
D15/199

* cited by examiner

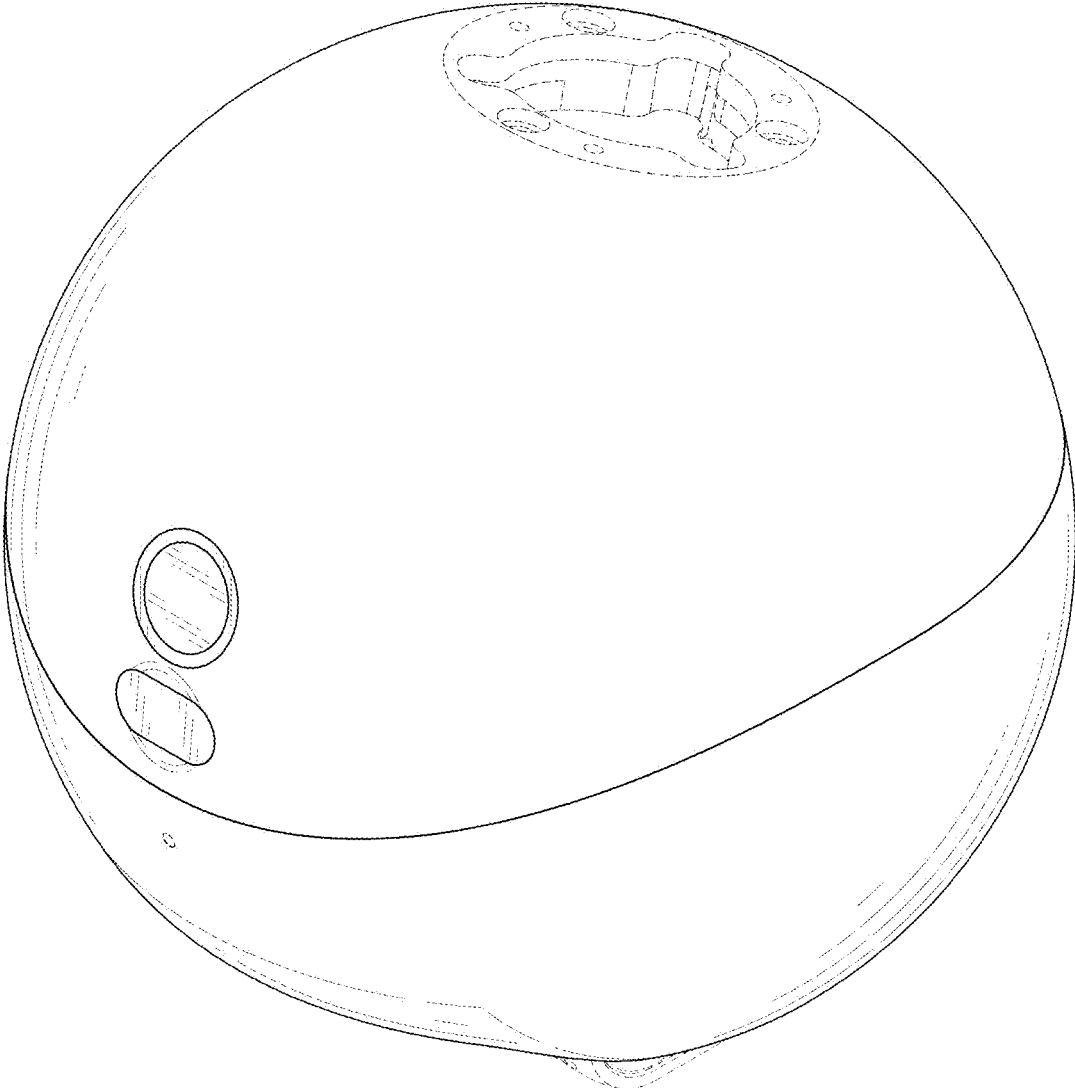

FIG.1

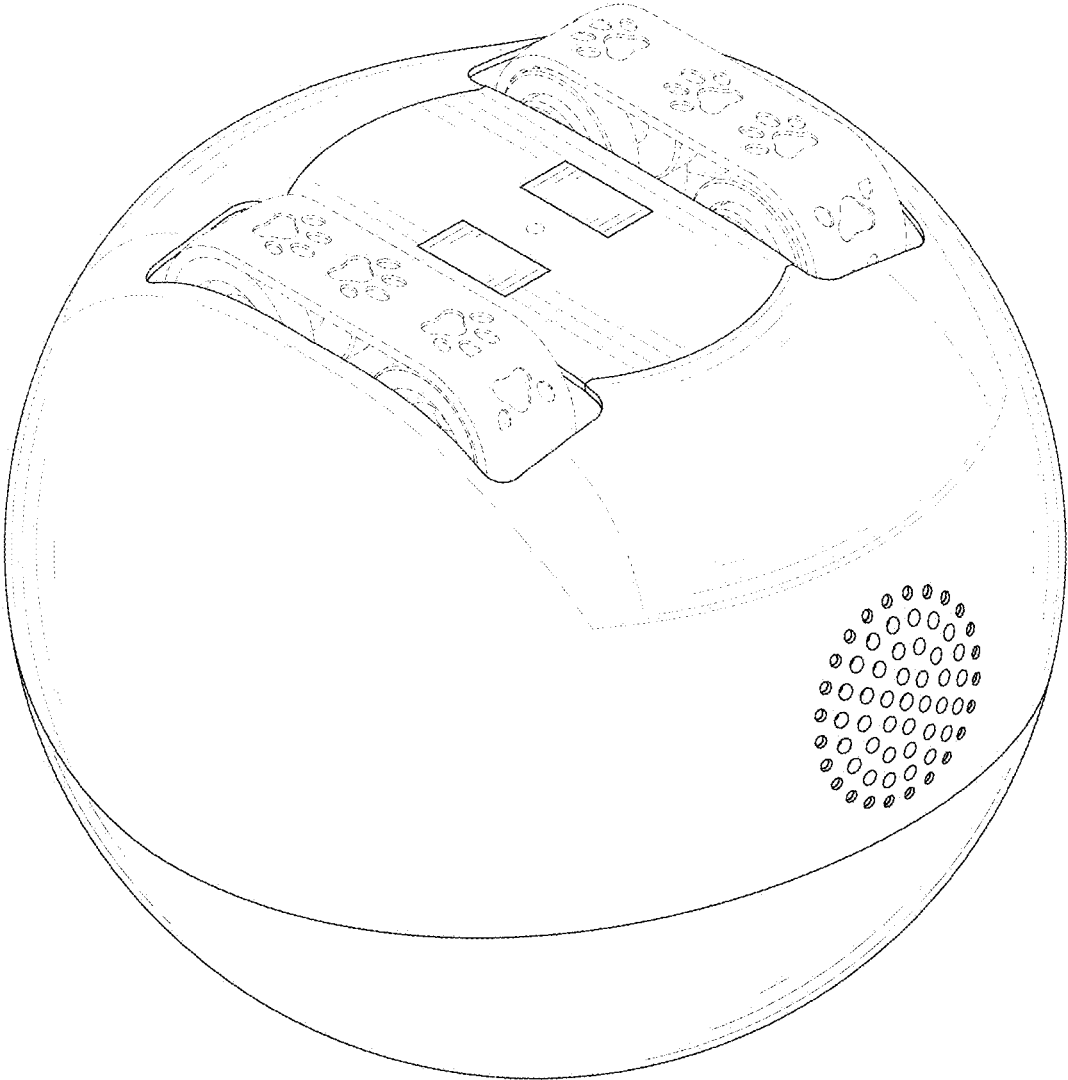

FIG.2

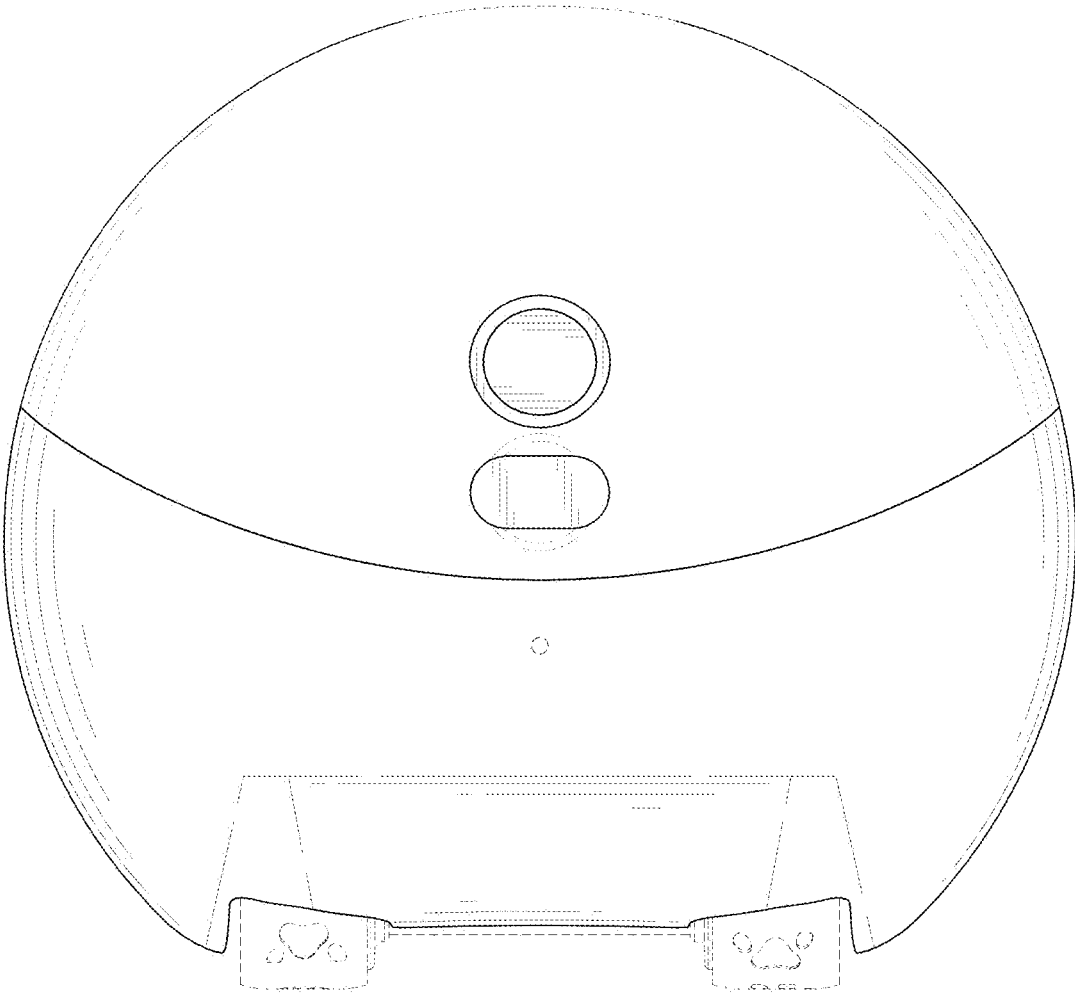

FIG.3

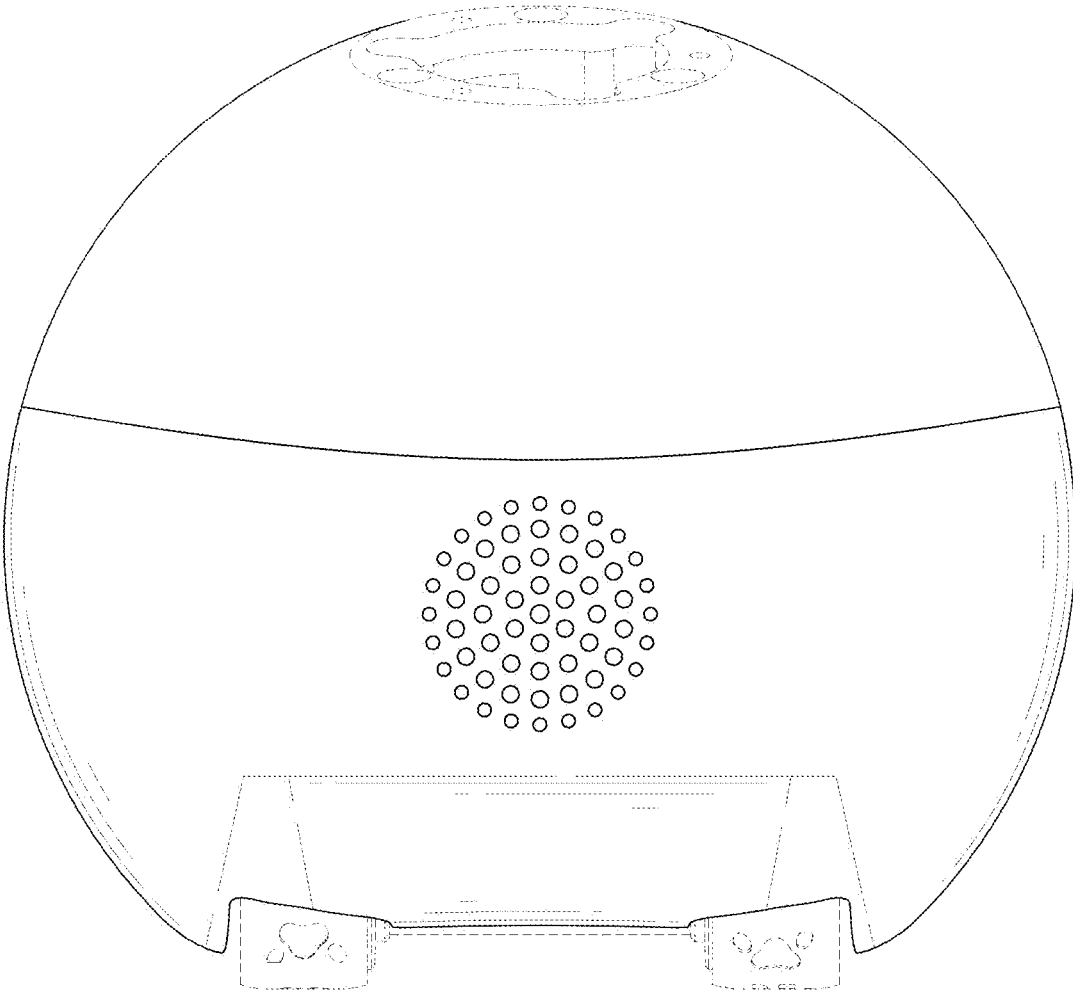

FIG.4

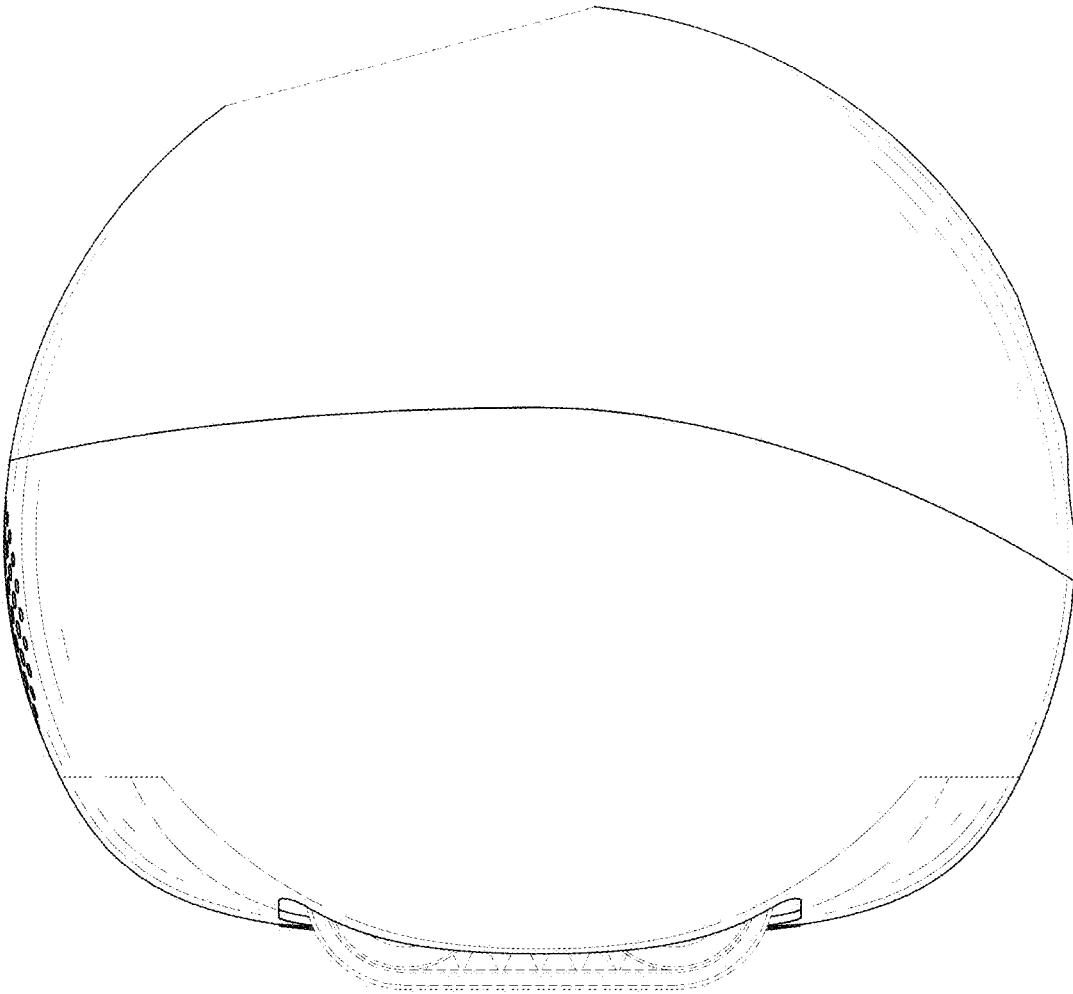

FIG.5

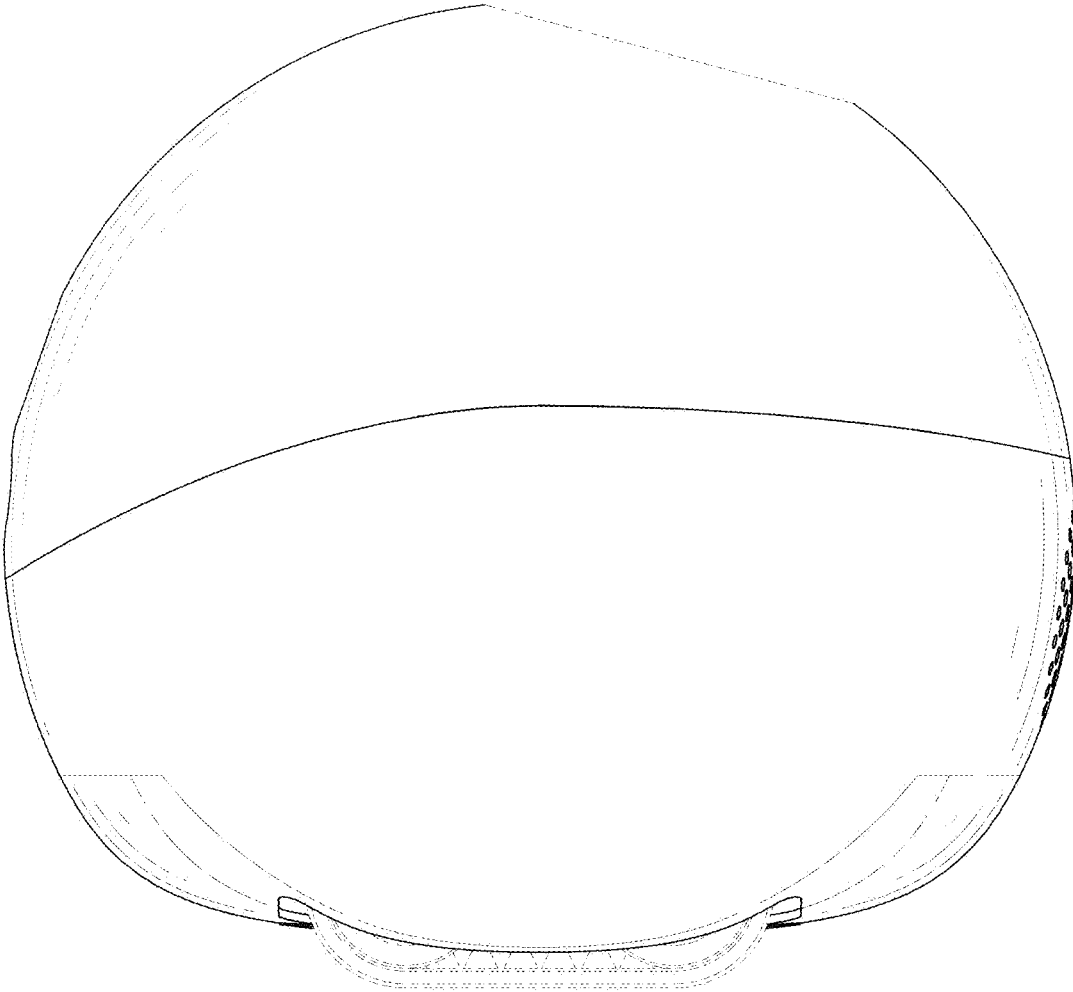

FIG.6



FIG.7

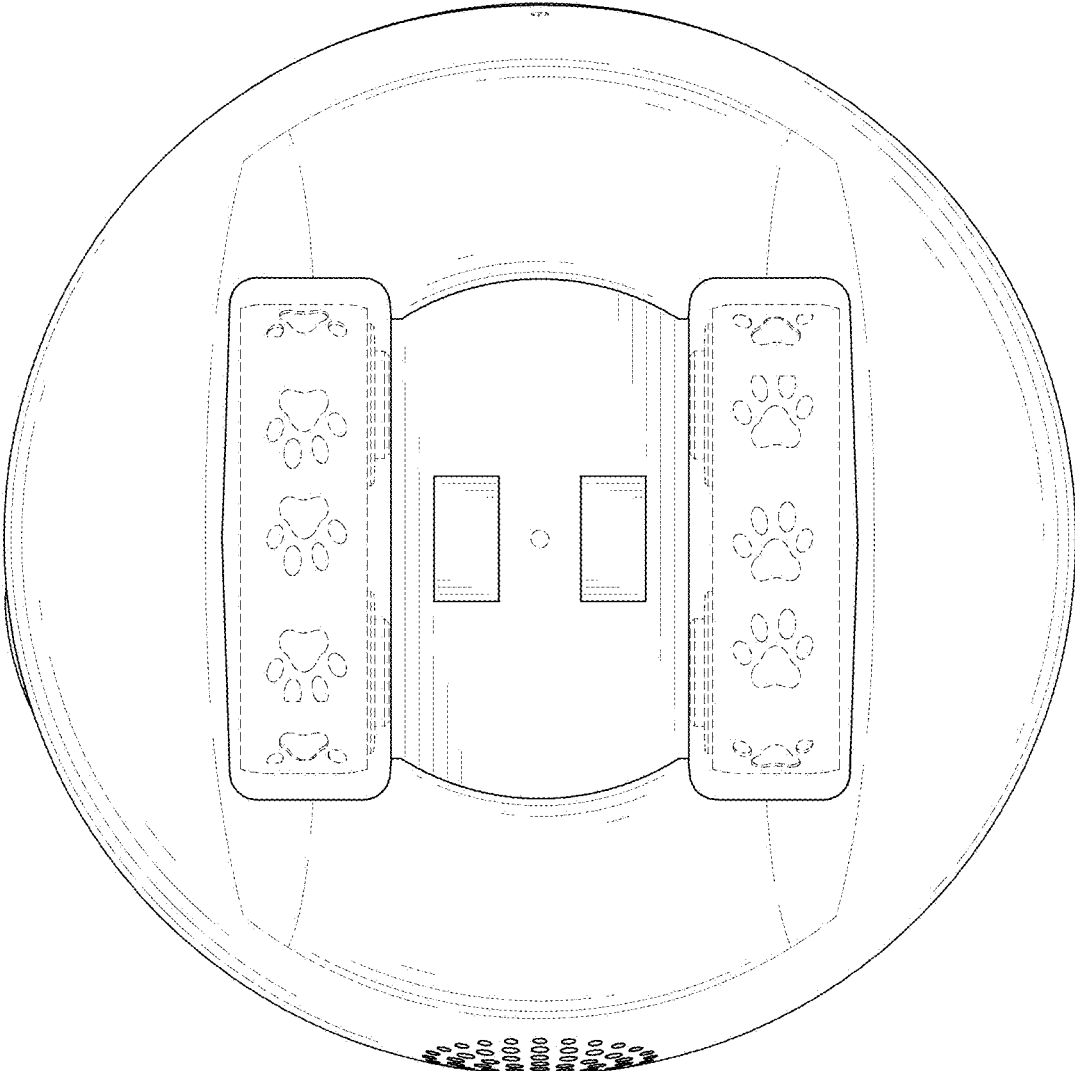

FIG.8