



US00D868660S

(12) **United States Design Patent**  
**De Leon**

(10) **Patent No.:** **US D868,660 S**

(45) **Date of Patent:** **\*\* Dec. 3, 2019**

- (54) **VEHICLE REAR VALANCE PANEL**
- (71) Applicant: **GM GLOBAL TECHNOLOGY OPERATIONS LLC**, Detroit, MI (US)
- (72) Inventor: **Reymin De Leon**, Birmingham, MI (US)
- (73) Assignee: **GM GLOBAL TECHNOLOGY OPERATIONS LLC**, Detroit, MI (US)
- (\*\*) Term: **15 Years**
- (21) Appl. No.: **29/673,560**
- (22) Filed: **Dec. 15, 2018**

- D605,083 S 12/2009 Manoogian, II et al.
- D605,977 S 12/2009 Zipfel et al.
- D605,978 S 12/2009 Wolff et al.
- D608,249 S 1/2010 Peters
- D608,690 S 1/2010 Folden et al.
- D608,691 S 1/2010 Zak, Jr. et al.
- D609,608 S 2/2010 Boniface et al.
- D611,387 S 3/2010 Thompson et al.
- D611,879 S 3/2010 Kim et al.
- D612,297 S 3/2010 Peters et al.
- D613,645 S 4/2010 Song et al.
- D615,458 S 5/2010 Thompson et al.
- D618,595 S 6/2010 Ware et al.
- D623,090 S 9/2010 Cox et al.
- D627,262 S 11/2010 Ikeda et al.
- D635,488 S 4/2011 Phipps
- D644,147 S 8/2011 Suh et al.
- D644,567 S 9/2011 Kozub
- D657,718 S 4/2012 Zipfel et al.

(Continued)

**Related U.S. Application Data**

- (62) Division of application No. 29/629,235, filed on Dec. 12, 2017, now Pat. No. Des. 849,630.
- (51) **LOC (12) Cl.** ..... **12-16**
- (52) **U.S. Cl.**  
USPC ..... **D12/196**
- (58) **Field of Classification Search**  
USPC ..... D12/86, 90, 91, 92, 163, 169, 171, 196, D12/216  
CPC ..... B60R 19/02; B60R 19/04; B60R 19/12; B60R 19/52; B60K 11/08; B62D 25/08  
See application file for complete search history.

*Primary Examiner* — Susan Bennett Hattan  
*Assistant Examiner* — Suzanne E Tisdell

(57) **CLAIM**

The ornamental design for a vehicle rear valance panel, as shown and described.

**DESCRIPTION**

FIG. 1 is a front and left perspective view of the vehicle rear valance panel according to a first embodiment of the present disclosure;  
 FIG. 2 is a left end elevation view thereof;  
 FIG. 3 is a front elevation view thereof; and,  
 FIG. 4 is a bottom plan view thereof.  
 The right end elevation view is omitted, because the right end elevation view is a mirror image to the left end elevation view.  
 The broken lines shown in the drawings depict portions of the vehicle rear valance panel that form no part of the claimed design.

**1 Claim, 2 Drawing Sheets**

(56) **References Cited**  
**U.S. PATENT DOCUMENTS**

- D570,742 S 6/2008 Takagi et al.
- D592,105 S 5/2009 Dean et al.
- D597,447 S 8/2009 Folden
- D600,595 S 9/2009 Nakamura et al.
- D601,925 S 10/2009 O'Donnell
- D603,755 S 11/2009 Peters
- D604,203 S 11/2009 O'Donnell
- D605,082 S 12/2009 Munson

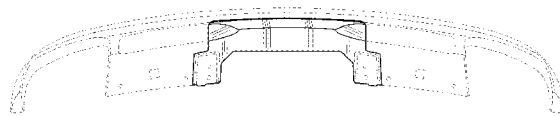

(56)

## References Cited

## U.S. PATENT DOCUMENTS

D659,052 S	5/2012	Ware et al.	
D659,053 S	5/2012	Ware et al.	
D668,182 S	10/2012	Barba Franco et al.	
D668,183 S	10/2012	Smart	
D678,820 S	3/2013	Son et al.	
D678,821 S	3/2013	Ikeda et al.	
D680,909 S	4/2013	Munson et al.	
D680,910 S	4/2013	David	
D684,899 S	6/2013	Baker	
D686,536 S	7/2013	McCabe et al.	
D692,798 S	11/2013	Thurber	
D692,799 S	11/2013	Smith et al.	
D696,157 S	12/2013	Loeb	
D698,708 S	* 2/2014	Rupar	D12/169
D699,629 S	2/2014	Ikeda et al.	
D700,871 S	3/2014	O'Donnell et al.	
D701,800 S	* 4/2014	Campbell	D12/169
D703,103 S	4/2014	Lee	
D704,103 S	5/2014	Mack et al.	
D705,132 S	5/2014	Ware et al.	
D705,699 S	5/2014	Ware et al.	
D711,653 S	* 8/2014	Pacetti	D3/318
D712,322 S	* 9/2014	Kobayashi	D12/169
D712,805 S	* 9/2014	Murkett	D12/169
D713,298 S	9/2014	Dyson	
D713,764 S	9/2014	Ferlazzo et al.	
D716,696 S	11/2014	Thole et al.	
D716,706 S	11/2014	Thole et al.	
D716,709 S	11/2014	Thole et al.	
D717,696 S	11/2014	Thole et al.	
D718,189 S	11/2014	Krieg et al.	
D718,683 S	12/2014	Thole et al.	
D722,282 S	2/2015	Loeb	
D722,533 S	2/2015	Thole et al.	
D722,534 S	2/2015	Munson et al.	
D724,510 S	3/2015	McMahan et al.	
D725,001 S	3/2015	McMahan et al.	
D726,591 S	4/2015	Jacob	
D730,776 S	6/2015	Smart	
D730,783 S	6/2015	Henriques et al.	
D732,427 S	6/2015	Loeb	
D732,429 S	6/2015	Loeb	
D732,430 S	6/2015	Loeb	
D732,431 S	6/2015	Loeb	
D732,432 S	6/2015	Aengenheyster	
D732,433 S	6/2015	Aengenheyster	
D732,435 S	6/2015	Mackay	
D733,002 S	6/2015	Loeb	
D735,611 S	8/2015	Aengenheyster	
D735,627 S	8/2015	Smith	
D736,451 S	8/2015	Smith	
D739,306 S	9/2015	McMahan et al.	
D739,317 S	9/2015	McMahan et al.	
D741,223 S	10/2015	Kim et al.	
D742,119 S	* 11/2015	Batista	D3/318
D743,309 S	11/2015	Thole et al.	
D743,313 S	11/2015	Smith et al.	
D743,314 S	11/2015	Thole et al.	
D743,857 S	11/2015	McMahan et al.	
D744,158 S	11/2015	Willett et al.	
D744,915 S	* 12/2015	Curic	D12/169
D745,086 S	12/2015	Finos et al.	
D745,719 S	12/2015	Boniface et al.	
D745,725 S	12/2015	McMahan et al.	
D745,726 S	12/2015	McMahan et al.	
D745,837 S	12/2015	Smith et al.	
D746,726 S	1/2016	Smith et al.	
D746,727 S	1/2016	Smith et al.	
D746,728 S	1/2016	Smith et al.	
D746,729 S	1/2016	Boniface et al.	
D746,730 S	1/2016	Kim et al.	
D747,514 S	1/2016	McMahan et al.	
D747,515 S	1/2016	McMahan et al.	
D747,819 S	1/2016	Thole et al.	
D749,021 S	2/2016	Boniface et al.	
D749,026 S	2/2016	Smith et al.	
D749,027 S	2/2016	McMahan et al.	
D749,246 S	2/2016	Thole et al.	
D749,249 S	2/2016	Thole et al.	
D749,250 S	2/2016	Thole et al.	
D749,985 S	2/2016	Kozub et al.	
D749,997 S	2/2016	McMahan et al.	
D750,001 S	2/2016	Thole et al.	
D751,003 S	* 3/2016	Rupar	D12/163
D751,007 S	* 3/2016	Curic	D12/169
D753,032 S	4/2016	Smith et al.	
D753,033 S	4/2016	Thole et al.	
D753,034 S	4/2016	Thole et al.	
D753,035 S	4/2016	Boniface et al.	
D753,036 S	* 4/2016	Curic	D12/169
D753,559 S	4/2016	McMahan et al.	
D753,560 S	4/2016	McMahan et al.	
D753,567 S	4/2016	Boniface et al.	
D754,571 S	4/2016	Boniface et al.	
D754,572 S	4/2016	McMahan et al.	
D755,088 S	5/2016	McMahan et al.	
D756,869 S	5/2016	McMahan et al.	
D758,259 S	* 6/2016	Messale	D12/169
D758,271 S	6/2016	McMahan et al.	
D762,147 S	* 7/2016	Messale	D12/169
D763,143 S	* 8/2016	Varga	D12/169
D763,744 S	* 8/2016	Behmer	D12/169
D764,975 S	8/2016	Aengenheyster	
D764,976 S	8/2016	Aengenheyster	
D767,449 S	9/2016	Pevovar et al.	
D767,450 S	9/2016	Lee et al.	
D767,451 S	9/2016	Kozub et al.	
D767,454 S	9/2016	McMahan et al.	
D767,458 S	9/2016	Kim	
D767,459 S	9/2016	Kim	
D767,460 S	9/2016	Kozub et al.	
D767,461 S	9/2016	Kozub et al.	
D771,528 S	11/2016	Smith et al.	
D771,529 S	11/2016	Thole et al.	
D771,532 S	11/2016	Kapitonov	
D771,533 S	11/2016	Kapitonov	
D771,536 S	* 11/2016	Wolff	D12/169
D772,766 S	11/2016	Kozub et al.	
D772,767 S	11/2016	Kim	
D773,084 S	11/2016	Kapitonov	
D773,086 S	11/2016	McCabe et al.	
D774,226 S	12/2016	McCabe et al.	
D775,003 S	12/2016	Pevovar et al.	
D775,007 S	12/2016	Thole et al.	
D775,010 S	12/2016	Kim et al.	
D775,038 S	* 12/2016	Frascella	D12/169
D775,049 S	12/2016	Scheer et al.	
D775,549 S	1/2017	Karras	
D775,554 S	1/2017	Kapitonov	
D776,020 S	1/2017	Kapitonov	
D776,021 S	* 1/2017	Kapitonov	D12/169
D776,581 S	1/2017	Pevovar et al.	
D776,583 S	1/2017	Scheer et al.	
D776,841 S	1/2017	Kozub et al.	
D776,843 S	1/2017	McCabe et al.	
D776,846 S	1/2017	Willett et al.	
D777,359 S	1/2017	Kozub et al.	
D777,360 S	1/2017	Kozub et al.	
D777,361 S	1/2017	Kozub et al.	
D777,604 S	1/2017	McNerney	
D777,605 S	1/2017	Ferlazzo et al.	
D777,620 S	1/2017	Pevovar et al.	
D777,621 S	1/2017	Kim	
D777,622 S	1/2017	Kozub et al.	
D777,628 S	1/2017	Kozub et al.	
D777,955 S	1/2017	Willett et al.	
D778,212 S	2/2017	Kozub et al.	
D778,215 S	2/2017	Kozub et al.	
D780,064 S	2/2017	Smith et al.	
D780,067 S	2/2017	Zipfel et al.	
D780,068 S	2/2017	Whitla et al.	
D780,077 S	2/2017	Kim et al.	
D780,081 S	2/2017	Lee	
D780,084 S	2/2017	Scheer et al.	

(56)

References Cited

U.S. PATENT DOCUMENTS

D780,631 S	3/2017	Kozub et al.	
D780,644 S	3/2017	Kim et al.	
D781,184 S	3/2017	Thole et al.	
D781,192 S	3/2017	Kozub et al.	
D781,586 S *	3/2017	Reinhart .....	D3/318
D781,587 S *	3/2017	Mangano .....	D3/318
D782,379 S	3/2017	Wassell	
D783,482 S	4/2017	Smith et al.	
D784,213 S	4/2017	Karras	
D784,223 S	4/2017	Lee	
D784,226 S	4/2017	Cheng	
D784,579 S	4/2017	Cheng et al.	
D784,877 S	4/2017	Lee	
D784,886 S	4/2017	Smith et al.	
D785,521 S	5/2017	Smith et al.	
D786,149 S	5/2017	Pevovar et al.	
D786,743 S	5/2017	Smith et al.	
D786,750 S	5/2017	Lee	
D787,446 S	5/2017	Cockerill	
D787,984 S	5/2017	Fang	
D787,988 S	5/2017	Lee	
D787,989 S	5/2017	Kozub et al.	
D787,990 S	5/2017	Kozub et al.	
D787,992 S	5/2017	Lee	
D787,993 S	5/2017	McCabe et al.	
D788,001 S	5/2017	Lee	
D788,641 S	6/2017	Arnold	
D788,644 S	6/2017	Mueller	
D788,645 S	6/2017	Mueller	
D789,250 S	6/2017	Arnold	
D789,260 S	6/2017	Smith	
D789,575 S	6/2017	Willett	
D789,841 S	6/2017	Lee	
D789,849 S	6/2017	Lee	
D791,018 S	7/2017	Mylenek	
D791,644 S	7/2017	Fang	
D792,290 S	7/2017	Smith et al.	
D792,293 S	7/2017	McCabe et al.	
D792,294 S	7/2017	McCabe et al.	
D792,295 S	7/2017	McCabe et al.	
D792,815 S	7/2017	Kozub	
D792,816 S	7/2017	Kozub	
D793,290 S	8/2017	Kozub	
D793,292 S	8/2017	Lee	
D793,293 S	8/2017	Lee et al.	
D793,294 S *	8/2017	Lee .....	D12/169
D793,295 S *	8/2017	McCabe .....	D12/169
D793,296 S	8/2017	Smith et al.	
D793,297 S	8/2017	Smith et al.	
D793,299 S	8/2017	Krieg et al.	
D793,300 S	8/2017	Krieg et al.	
D793,301 S	8/2017	Kozub	
D793,302 S	8/2017	Kozub	
D793,311 S	8/2017	Whitla et al.	
D793,590 S	8/2017	Kozub et al.	
D793,591 S	8/2017	Kozub et al.	
D793,917 S	8/2017	Kozub	
D793,918 S	8/2017	Kozub	
D794,229 S	8/2017	Barry	
D794,230 S	8/2017	Kozub	
D795,747 S	8/2017	Bailie	
D795,757 S	8/2017	Pevovar et al.	
D795,758 S	8/2017	Karras	
D795,759 S	8/2017	Kozub et al.	
D795,760 S	8/2017	Kozub et al.	
D795,762 S	8/2017	Lee	
D795,763 S	8/2017	Kozub	
D796,088 S	8/2017	McCabe et al.	
D796,093 S	8/2017	Mainville	
D796,390 S	9/2017	Pevovar et al.	
D797,456 S *	9/2017	Chen .....	D3/318
D797,537 S	9/2017	Cooper et al.	
D797,603 S	9/2017	Noone et al.	
D797,614 S	9/2017	Lee	
D797,616 S *	9/2017	Lee .....	D12/169
D797,624 S	9/2017	Nakamura	
D797,625 S	9/2017	Perkins	
D797,631 S	9/2017	Pevovar et al.	
D797,632 S	9/2017	Zipfel et al.	
D797,967 S	9/2017	Barry	
D797,970 S	9/2017	Mainville	
D797,971 S	9/2017	Mainville	
D797,972 S	9/2017	Whitla et al.	
D798,201 S *	9/2017	Zavatski .....	D12/169
D798,204 S	9/2017	Mainville	
D799,384 S	10/2017	Kozub et al.	
D799,385 S	10/2017	Kozub et al.	
D799,386 S	10/2017	Kozub et al.	
D799,728 S	10/2017	Whitla et al.	
D800,621 S *	10/2017	Bucher .....	D12/196
D801,236 S *	10/2017	Kozub .....	D12/169
D801,577 S	10/2017	Ruiz	
D801,882 S	11/2017	Kozub et al.	
D802,205 S	11/2017	Ruiz	
D802,478 S	11/2017	Perkins	
D802,491 S	11/2017	Mainville	
D802,496 S	11/2017	Mainville	
D802,502 S	11/2017	McMahan	
D803,727 S	11/2017	Noone et al.	
D803,731 S	11/2017	Zipfel	
D803,738 S *	11/2017	Granlund .....	D12/169
D804,370 S	12/2017	Kozub et al.	
D804,371 S	12/2017	Whitla et al.	
D804,372 S	12/2017	Kozub	
D804,378 S	12/2017	Perkins	
D804,379 S	12/2017	McMahan	
D805,006 S	12/2017	Nakamura	
D805,013 S	12/2017	Whitla et al.	
D805,014 S	12/2017	Zipfel et al.	
D805,441 S	12/2017	Karras	
D805,964 S	12/2017	Whitla et al.	
D805,965 S	12/2017	Davis	
D805,966 S	12/2017	Perkins	
D805,985 S	12/2017	Nakamura	
D807,232 S	1/2018	Bailie	
D807,239 S	1/2018	Perkins	
D807,240 S	1/2018	Perkins	
D807,241 S	1/2018	Perkins	
D807,255 S *	1/2018	Piscitelli .....	D12/169
D809,442 S	2/2018	Zipfel et al.	
D811,269 S	2/2018	Thompson et al.	
D811,942 S	3/2018	Jacob	
D811,957 S	3/2018	Whitla et al.	
D811,958 S	3/2018	Zipfel et al.	
D811,959 S	3/2018	Perkins	
D811,960 S	3/2018	Nakamura	
D811,961 S	3/2018	Sullivan	
D811,962 S	3/2018	Sullivan	
D811,963 S	3/2018	Sullivan	
D811,964 S	3/2018	Perkins	
D811,965 S	3/2018	Moffett et al.	
D812,525 S	3/2018	Lee	
D812,526 S	3/2018	Zipfel et al.	
D812,527 S	3/2018	Perkins	
D812,528 S	3/2018	Nakamura	
D813,098 S	3/2018	Thompson et al.	
D813,109 S	3/2018	Zipfel et al.	
D813,110 S	3/2018	Whitla et al.	
D813,111 S	3/2018	Sullivan	
D813,116 S	3/2018	Park	
D813,117 S	3/2018	Sullivan	
D813,121 S	3/2018	Swanseger	
D813,730 S	3/2018	Zipfel et al.	
D813,731 S	3/2018	McMahan	
D813,732 S	3/2018	Whitla et al.	
D813,733 S	3/2018	Lee	
D813,734 S	3/2018	Nakamura	
D813,740 S	3/2018	Park	
D813,741 S	3/2018	Perkins	
D813,742 S	3/2018	McMahan et al.	
D813,743 S	3/2018	Lee	
D813,744 S	3/2018	Whitla et al.	
D813,748 S	3/2018	Kim	
D813,753 S	3/2018	Loeb	

(56)

**References Cited**

## U.S. PATENT DOCUMENTS

D813,754 S	3/2018	Loeb	D818,907 S	5/2018	Whitla et al.
D813,755 S	3/2018	Loeb	D818,915 S	5/2018	Kozub et al.
D813,756 S	3/2018	Loeb	D818,922 S	5/2018	Whitla et al.
D813,757 S	3/2018	Kozub	D819,505 S	6/2018	McMahan et al.
D813,758 S	3/2018	Gonzales	D819,519 S	6/2018	Whitla et al.
D813,759 S	3/2018	Perkins	D821,617 S	6/2018	Perkins
D814,369 S	4/2018	Loeb	D822,550 S	7/2018	Wassell et al.
D814,982 S	4/2018	Whitla et al.	D822,551 S	7/2018	McMahan et al.
D814,983 S	4/2018	Whitla et al.	D823,188 S	7/2018	Loeb
D815,570 S	4/2018	McMahan et al.	D823,738 S	7/2018	Kim
D815,572 S	4/2018	Perkins	D823,741 S	7/2018	Kim
D815,573 S	4/2018	Whitla et al.	D823,762 S	7/2018	Loeb
D815,574 S	4/2018	Mainville	D823,763 S	7/2018	Koo et al.
D815,985 S	4/2018	Mueller	D824,811 S	8/2018	Mainville
D815,993 S	4/2018	Kozub et al.	D824,812 S	8/2018	Loeb
D815,994 S	4/2018	Nakamura	D824,824 S	8/2018	Kim
D816,003 S	4/2018	Perkins	D824,825 S	8/2018	Loeb
D816,558 S	5/2018	McMahan et al.	D825,083 S	8/2018	Perkins
D816,559 S	5/2018	McMahan et al.	D825,388 S	8/2018	Karras et al.
D816,561 S	5/2018	McMahan	D825,403 S	8/2018	Whitla et al.
D816,562 S	5/2018	Whitla et al.	D826,114 S	8/2018	Smith et al.
D816,563 S	5/2018	McMahan et al.	D826,435 S	8/2018	Kim
D816,564 S	5/2018	Kim	D826,803 S	8/2018	Smith et al.
D816,565 S	5/2018	Kim	D827,506 S	9/2018	McMahan et al.
D816,566 S	5/2018	Loeb	D827,508 S	9/2018	Whitla et al.
D817,836 S	5/2018	McMahan et al.	D827,510 S	9/2018	Kim
D818,156 S	5/2018	Kim et al.	D827,527 S	9/2018	Loeb
D818,157 S	5/2018	Zipfel et al.	D828,246 S	9/2018	Loeb
D818,158 S	5/2018	Zipfel et al.	D828,261 S	9/2018	Moffett et al.
D818,159 S	5/2018	Zipfel et al.	D828,935 S	9/2018	Hochmuth
D818,160 S	5/2018	Perkins	D829,622 S	10/2018	Jacob
D818,406 S	5/2018	McMahan et al.	D830,241 S	10/2018	Kozub
D818,876 S	5/2018	Whitla et al.	D830,242 S	10/2018	Zipfel
D818,877 S	5/2018	Nakamura et al.	D830,252 S	10/2018	Swaneger
D818,878 S	5/2018	McMahan et al.	D830,258 S	10/2018	Moffett et al.
D818,892 S	5/2018	Lee	D830,261 S	10/2018	Jacob
D818,893 S	5/2018	Kim	D830,589 S	10/2018	Henriques
D818,903 S	5/2018	Zipfel et al.	D832,752 S	11/2018	Lee
D818,906 S	5/2018	McMahan	D835,003 S	12/2018	Thompson et al.
			D835,012 S	12/2018	Smith et al.

\* cited by examiner

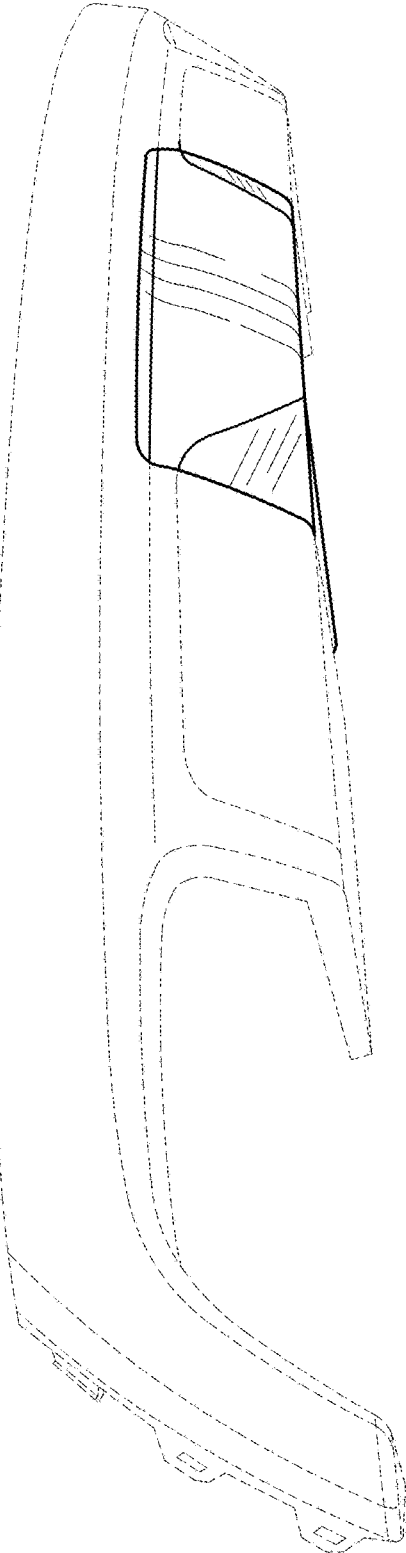

FIG - 1

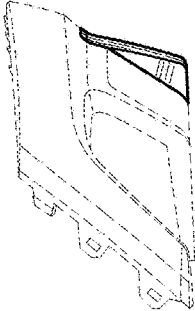
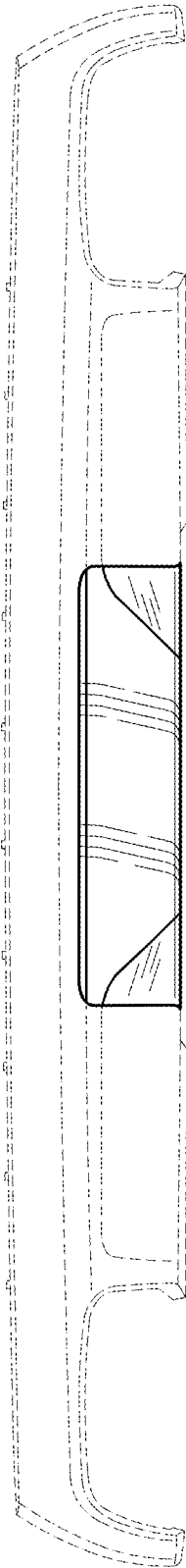
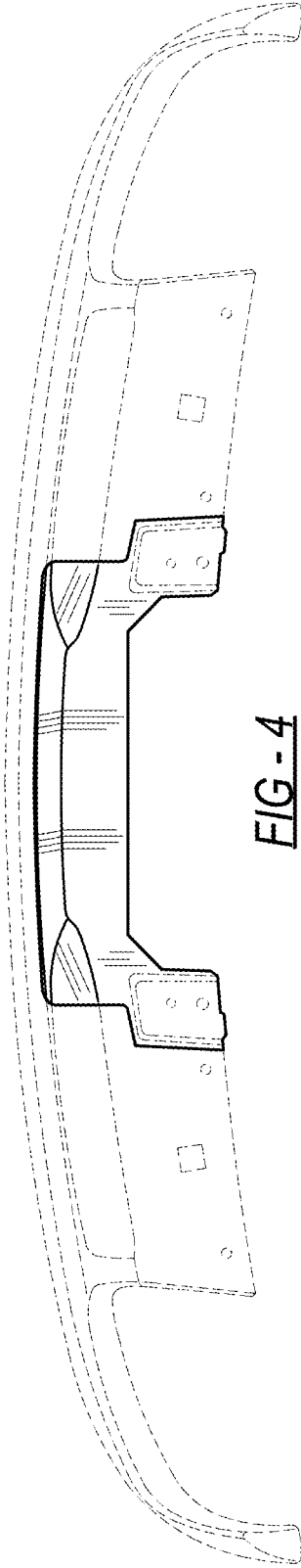

FIG - 2



*FIG - 3*



*FIG - 4*