

(19)
(12)

(KR)
(B1)

(51) 。 Int. Cl.⁷
H02K 15/10

(45)
(11)
(24)

2004 09 18
10-0449469
2004 09 09

(21) 10-2001-0049071
(22) 2001 08 14

(65)
(43)

10-2002-0073371
2002 09 26

(30) JP-P-2001-00073860 2001 03 15 (JP)

(73) 가 가 2 2 3

(72) 2 2-3 가 가

2 2-3 가 가

가 2 2-3 가 가

2 2-3 가 가

2 2-3 가 가

(74)

:

(54)

(7) , (7) (15) (15) (15) (16)
(8) (15) (15) (15a) (15f)
(15a) (100) , (15) (16) 가 (15g) (15f)
15a) (15b) (150) (150) (15) (15g) (15f) (

1	1
2	1
3	1
4	1
5	1
6	2
7	2
8	2
9	2
10	2
11	3
12	3
13	
14	
15	
16	
17	
18	
19	
20	
21	

1

< >

1 : , 2 : ,

3 : , 4 : ,

5 : , 6 : ,

7 : , 8 : ,

9 : , 10 : ,

11 : , 12 : ,

13 : , 15 : ,

15a : , 15c : ,

15d : , 15f : ,

15h : 15g : ,

16 : , 17 : ,

18 : , 19 : ,

20,21 : , 22,23 : ,

30 : , 50 : ,

100 : , 150 : .

(3) (6) , (8)가 (7) (3)
(6) (4)가 (6) (1) (2) 가 (6)
(9) (7) (9) (6) (11) (8) (10)가
(18)가 (11) (17) (8)
(7) (8) (12)가 (3) (8)
3) (13) (13) (1) (1)
8 (20),(21) (20),(21)
(22),(23) 가 (22),(23)
(6) (5) (7)
(1a),(2a) (1) (2) (1b),(2b)
(1) (2) (16) (16a),(16b)
(8) 14 (15a)
(15) (15) (16) (15a)
(16) (16) (15) (19)
(15a) (30) (15) (15a)
(15) (7) 16 , 3 (16) 2 96
(15a) 가 (30) 가
(8) 15 21 15 16
12 가 (30) 가 , 17 (30A)
가 18 2 (30) 21 6 (30B) (30A),(30B)
(30) 가 (30A),(30B) 6 (30a)가 (30A)
(15d) (15a) (15c)가 (30 °) SPCC
(150) 가 19
A),(30B) 20 (a) 21 (19)가 (36) (15a) , 2 (30
(30b) 20 (b) (15a) 2 (30A),(30B) (150) , (30)
(19) (150) (15a)
, 2 (30A),(30B) 21 (15a) 4
(150) (15g) , 20 (c)
(8)

(16) (15) (19)
(19) 가 (16) 가 (15) 가 (19)
가 가 가
(15) (15) (15c)
(15) (15c)
(19) (15c) (19)가 (15) (16)
(16)
, 21 (16) (15) (15a) A (15)
20(c) (16) (16) (16) (16)
c) (15) (16) (16) (15)
(16) (16) (16) (19)

19) (19) (15) (16) (16) (15a) ()
(16) (15) ()
가
가
가
1. 1 1 2 1
(15) (16) 가 (2) 0.35mm SPCC가 (15) ,
(15a) 가 (30) (19) (16) (16) (19)
(15) (100) (15) (15a)
(100)
(100)) (52) (51) (50) (51) (50)
(150) 가 (150) (15) (150) (15)
a) (, 2 (燒付) 가) (15f) (100) (150) (15)
(150) (15f) (100) (15f) (150)
4 (15f) 가 (100)) (150) 가
(100) , 가
(15a) 가
4 (15c) 5 (8) (15f)
(15a) 35μm, 20μm (15a) R (16) 20μm
(150) (15g) (100) (15)
(100) (150) (15g) (15c) (100)가 (15) 가
(15) (15c) (100)가 가
(100) (150) (15a) 15 21 (16)
) (15a) (15a) (30) (15) (16) , (16)
(16) (15a) (100)가
(150) (15g) (15) , 1
(8)가

(16) (15a) (19)

(100) 가 (150)

(100) (150) (150) 가 (15b)가

가 가 (150) (15a) (15) (15c) (15)

(100) (15) (15) (15)

(19) (100) (15) (15a) 가

(19) (100) (19)

(100) (15a) 가 (15)

(15) (19) (15a) 가 (100) (15a) (15)

가 가 (100) (15a)

1 (100) 가 (100)

100) 가 (100)

2.

6 2 7 8 1.6mm x 가 1.4mm x R 0.2mm

가 (30) 1 (16) 3 가 (100)

9 2 (15a) (100)

(15a) 가 (150) (15a) (15h) (15h) (15h)

50) (100) (15h) (15h) (15h)

가 (15a) (150) (15h)

(15a) (100) (15h) (15h)

10 9 (15d) 가 0.35mm (15e) 0.5mm (15f)

(16) (100) (16) R (15a) (100) (15a) R

가 (15e) (16) (15a) 가

가 9 (150) (16) (15a)

(100) (16) (15a) 가 (15c) 가 (15a) (1)

(15a) (100) 1

(30) (30) 1 (16) (15a)

(30) (16) (15a) 가

3.

11 (15) 3 (15f)가 (凹凸) (15) 11 (15f)
 가 (100) (凹凸) 가 (16) (15a) (100) (15) (15f)
 , 11 (15a) (凹凸) 가 (凹凸)
 가 (360d) , (361d) , (15c) (凹凸)
 , (凹凸) , 12
 (15d) R (凹凸) (150) (100) (150) (16)
) (15d) (15g) (15) (15)
 , (15) 가 (30) 가 (U , I , J)
 가 가 9-10352

가 가

가 ,
 가 .
 가 ,
 가 .

(57)

- 1.
- 2.
- 3.
- 4.
- 5.
- 6.
- 7.
- 8.
- 9.
- 10.

- 11.
- 12.
- 13.
- 14.
- 15.
- 16.
- 17.
- 18.
- 19.
- 20.
- 21.
- 22.

가

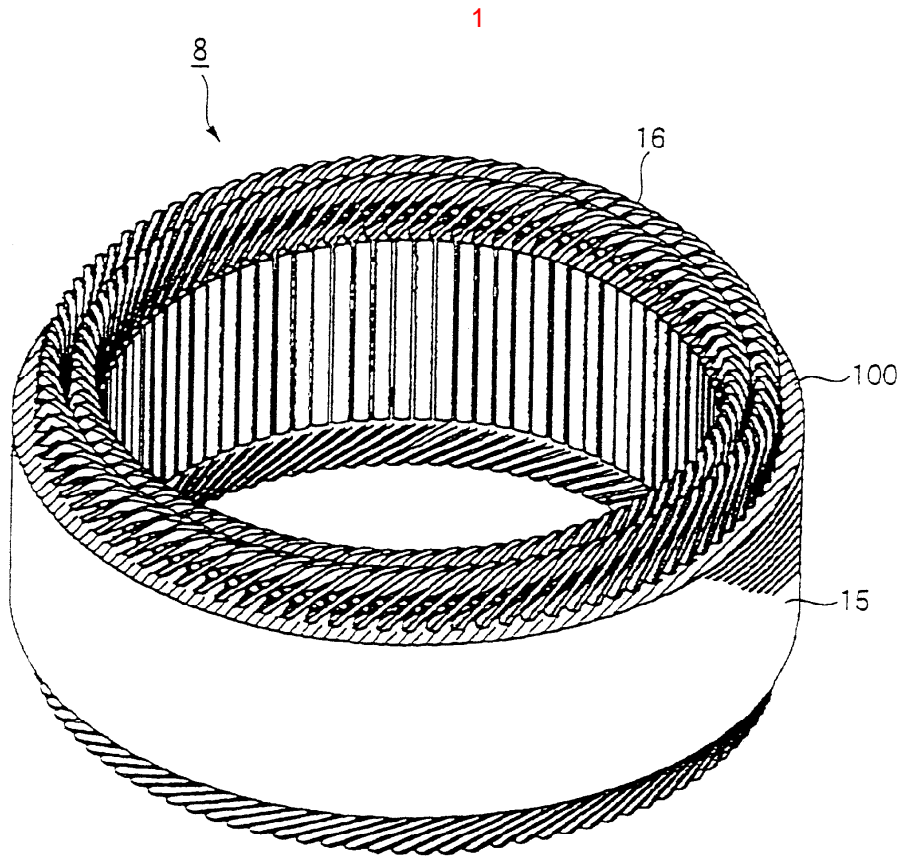

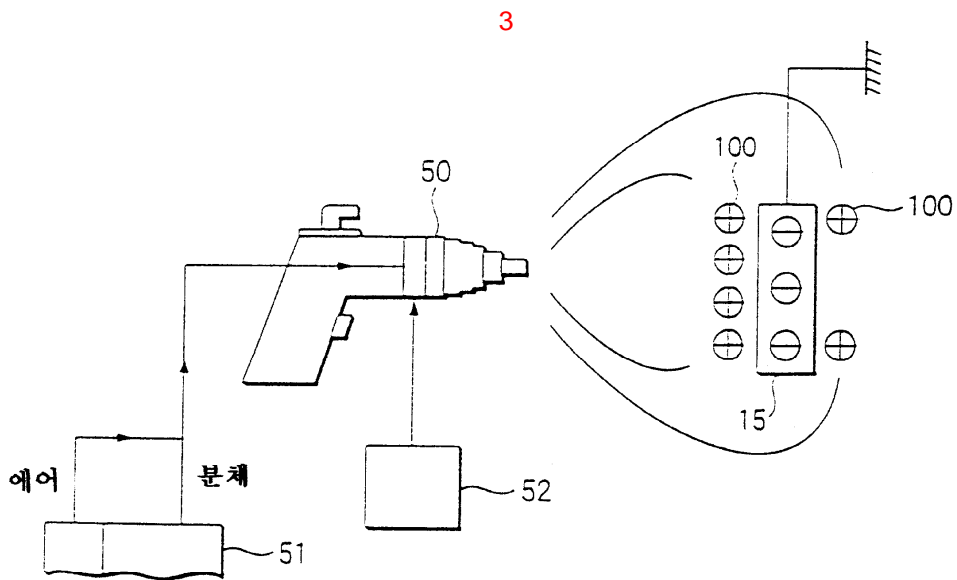
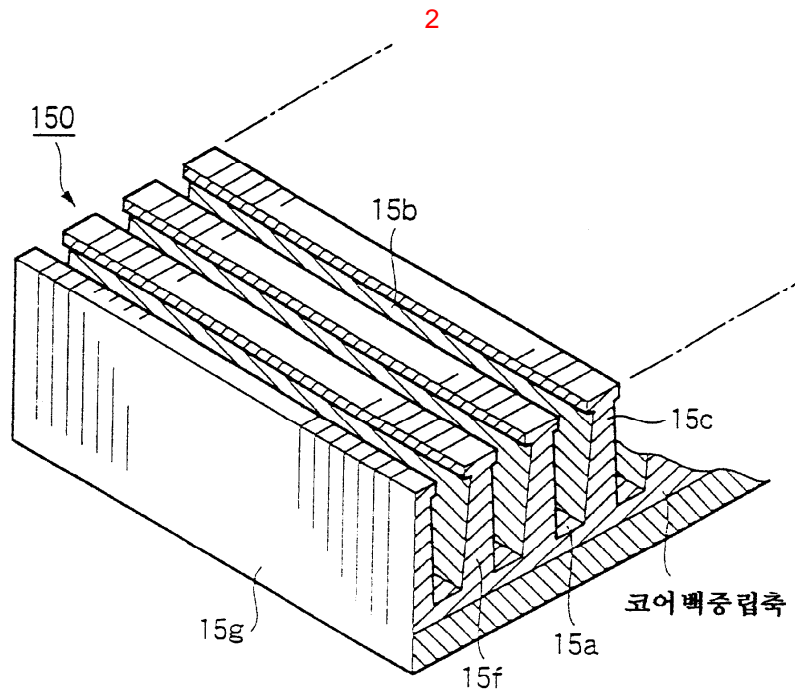

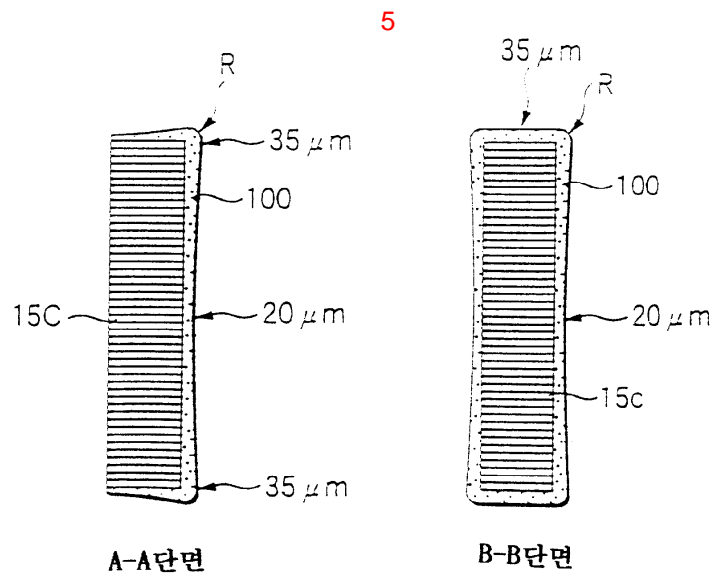
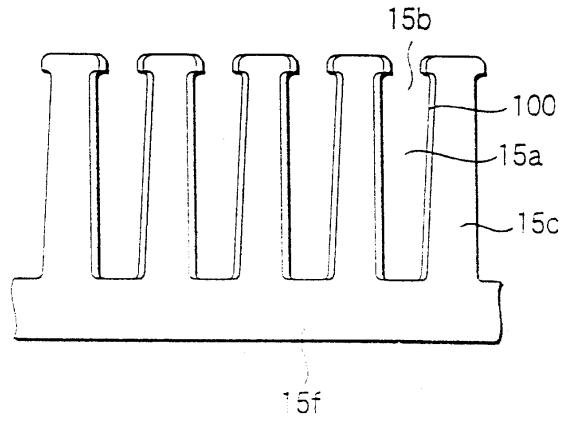
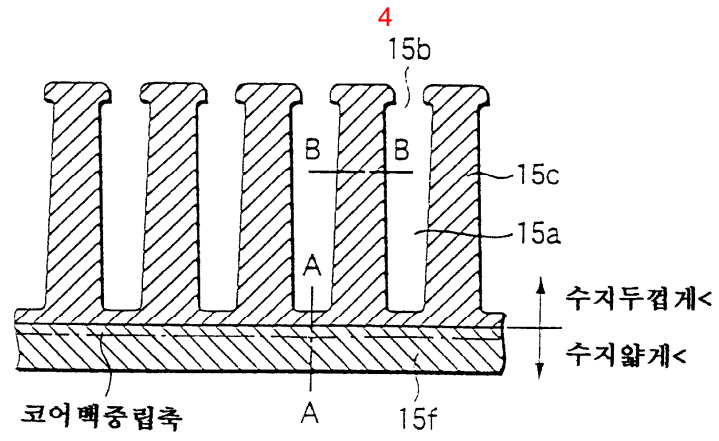

6

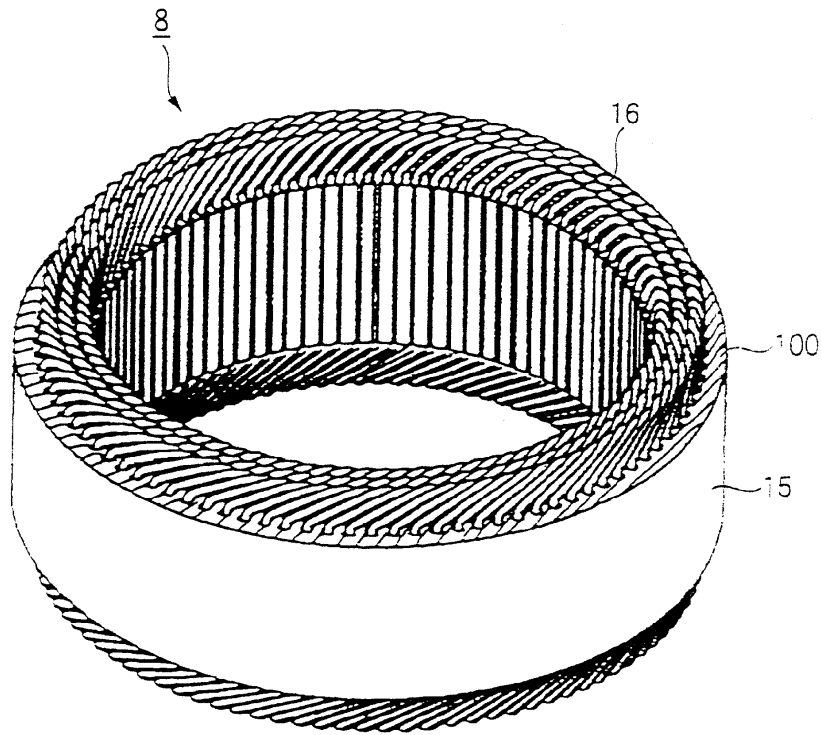

7

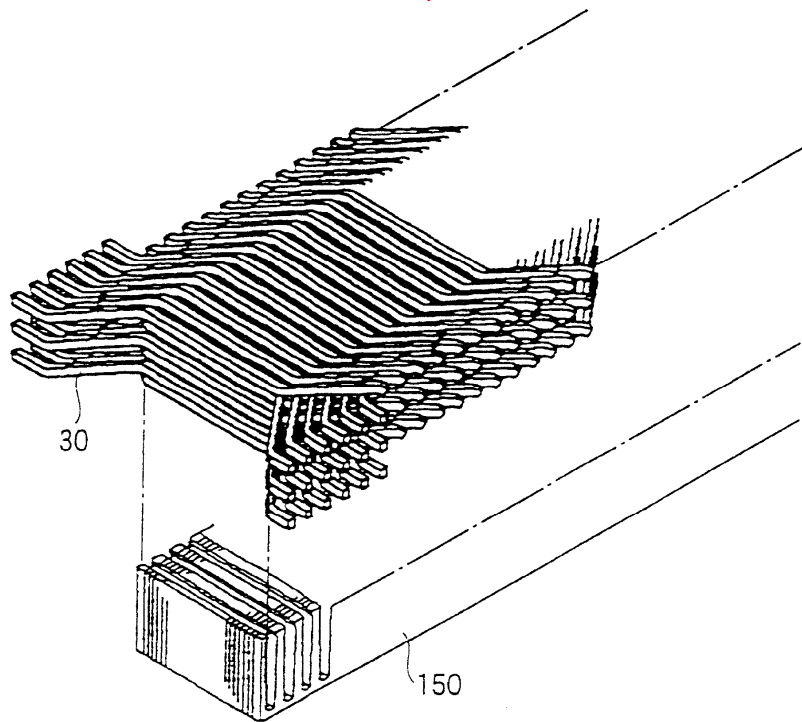

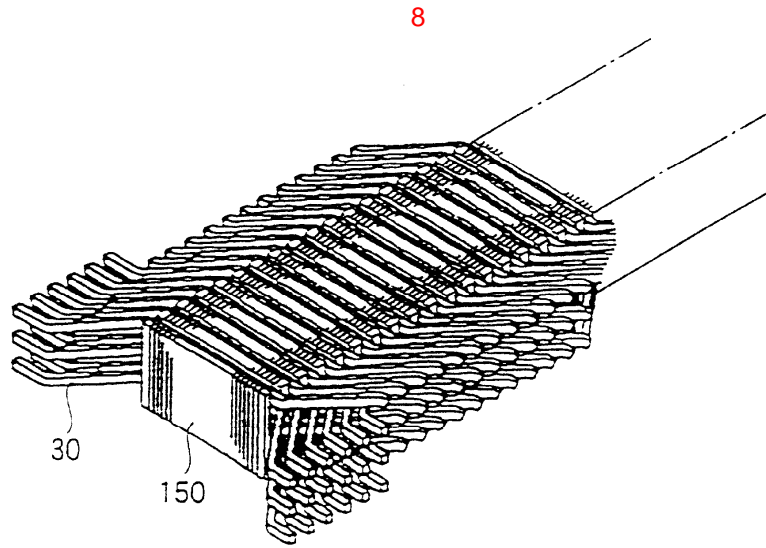

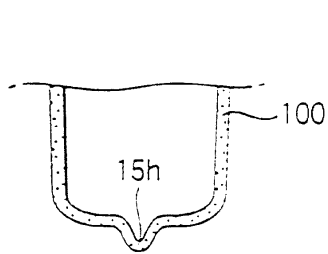
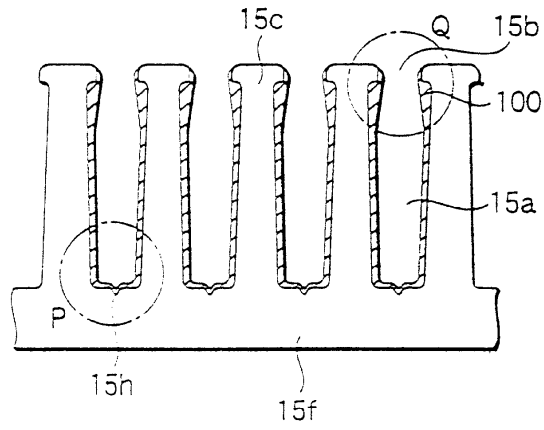
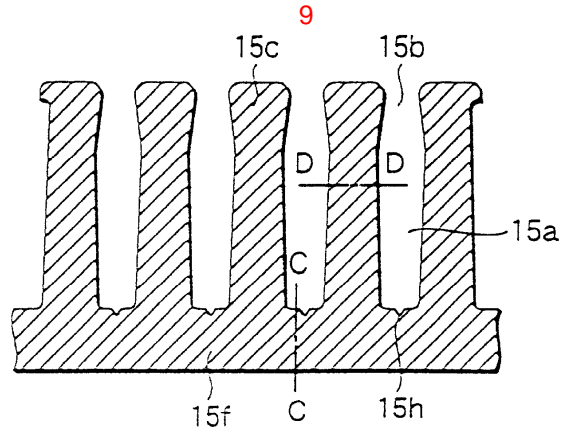

P부상세도

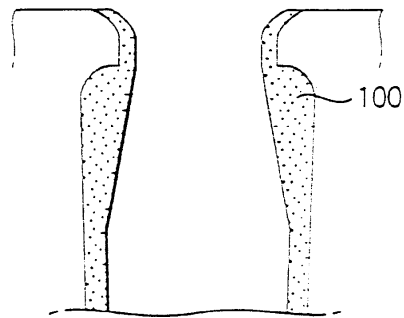

Q부상세도

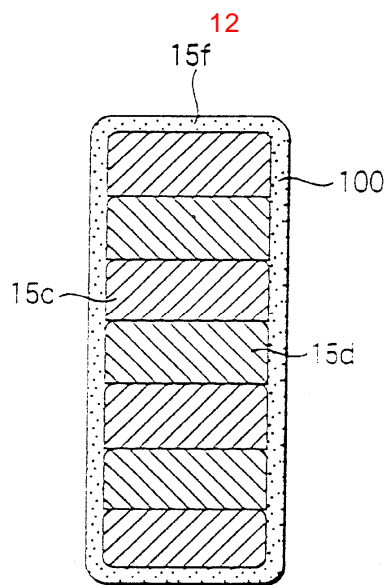
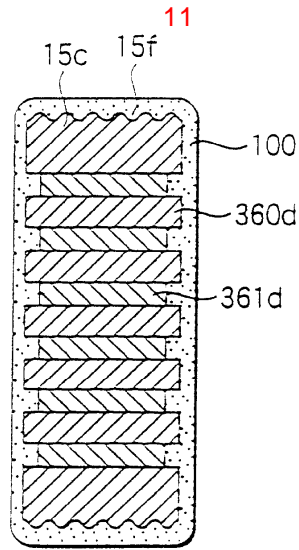
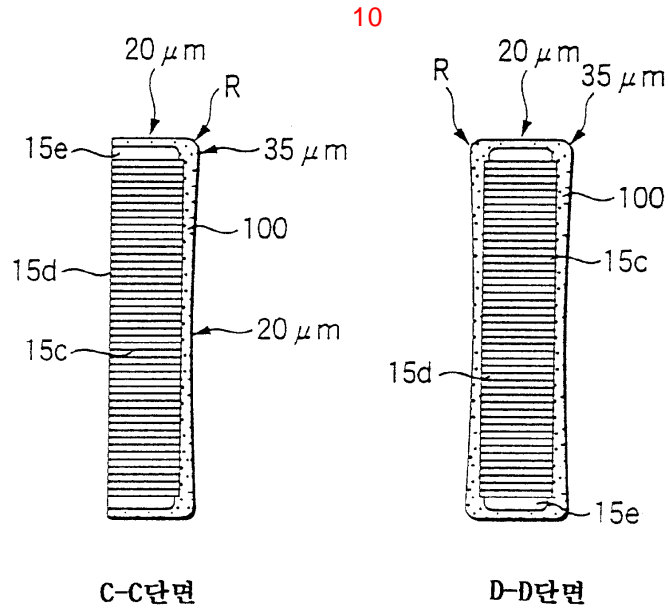

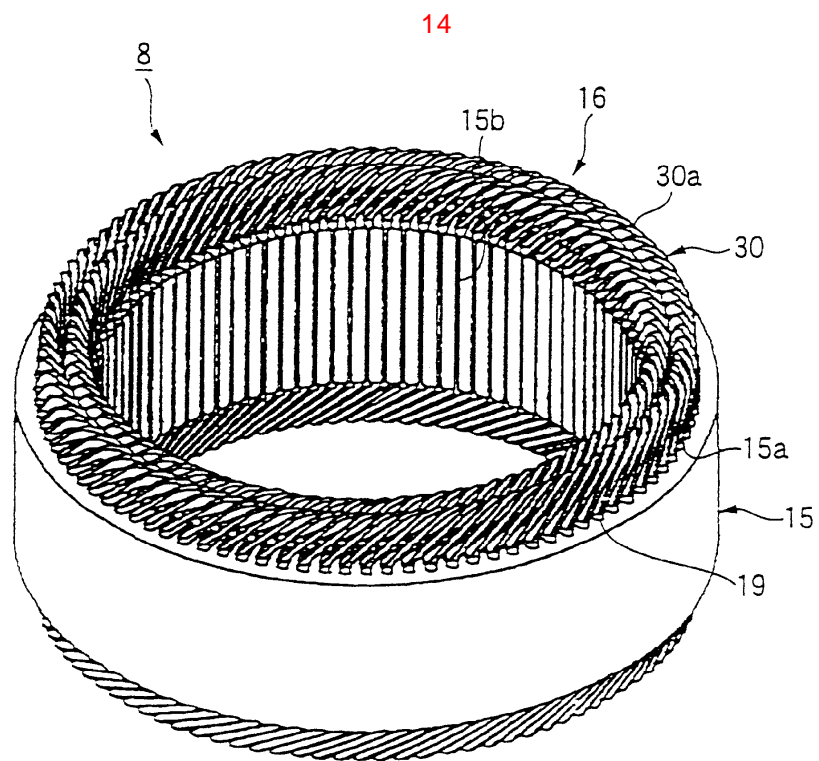
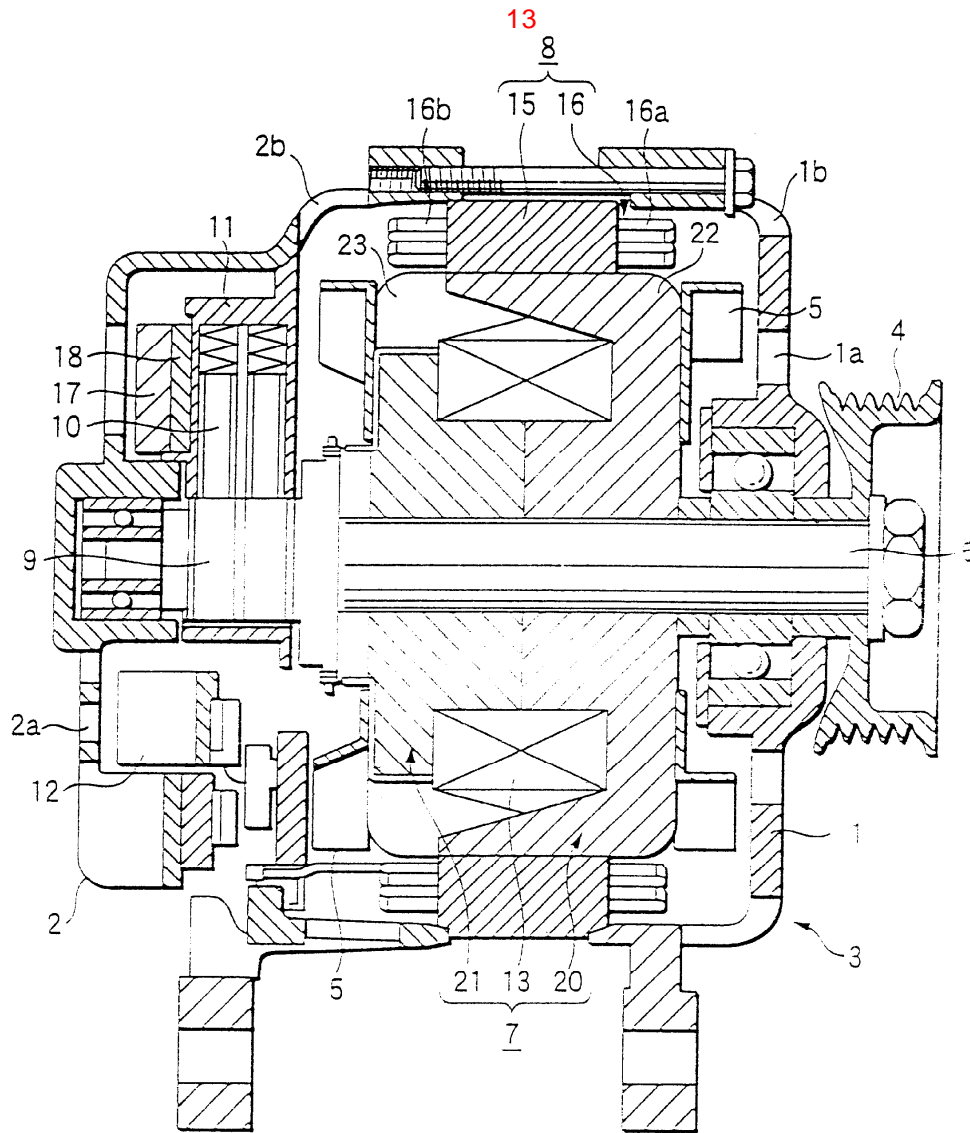

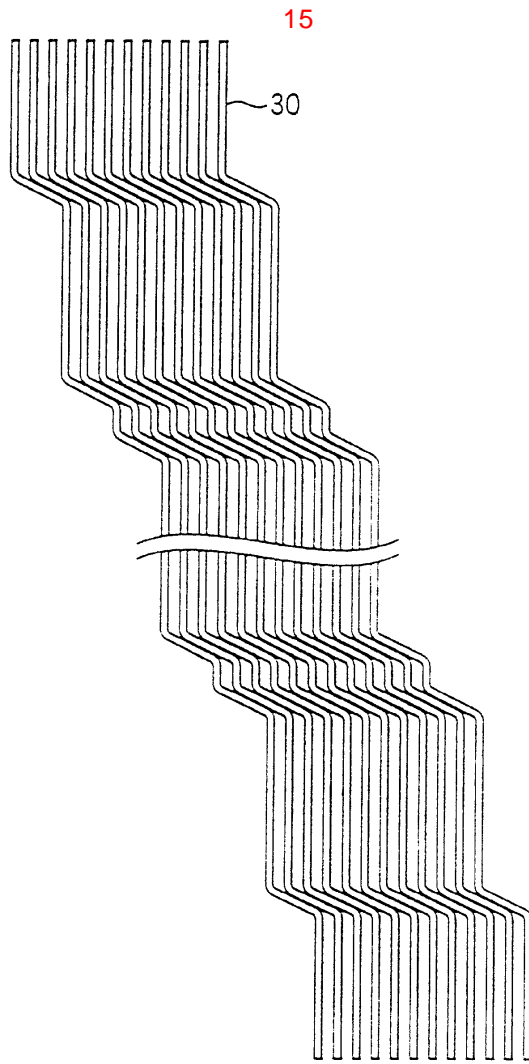

16

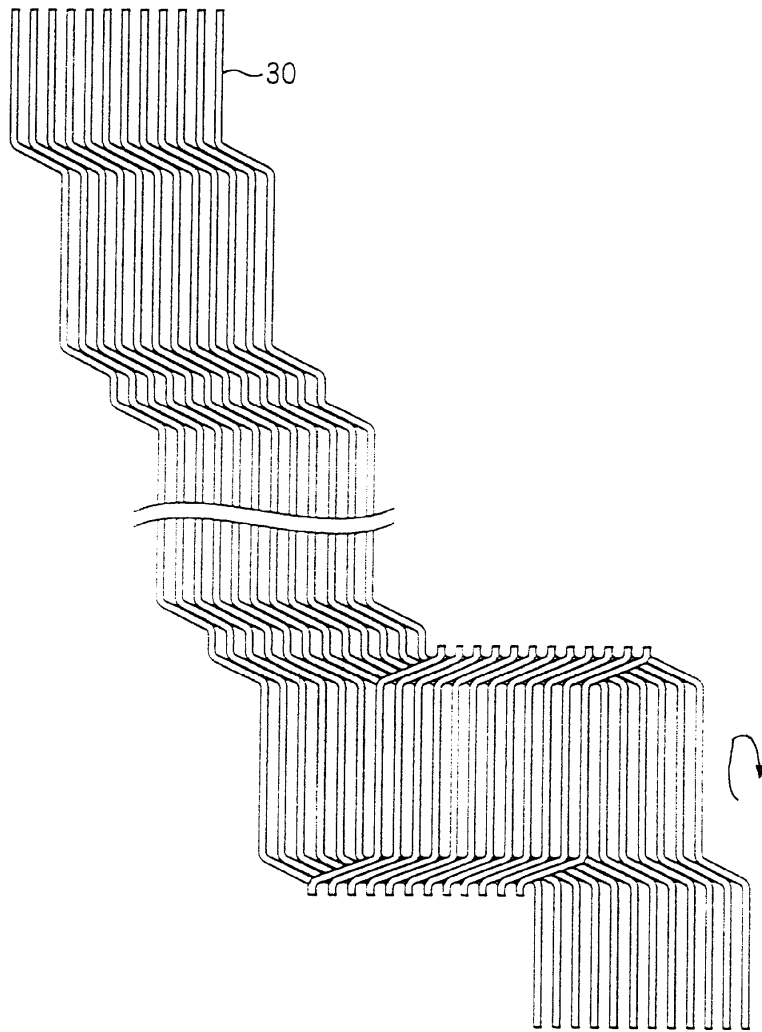

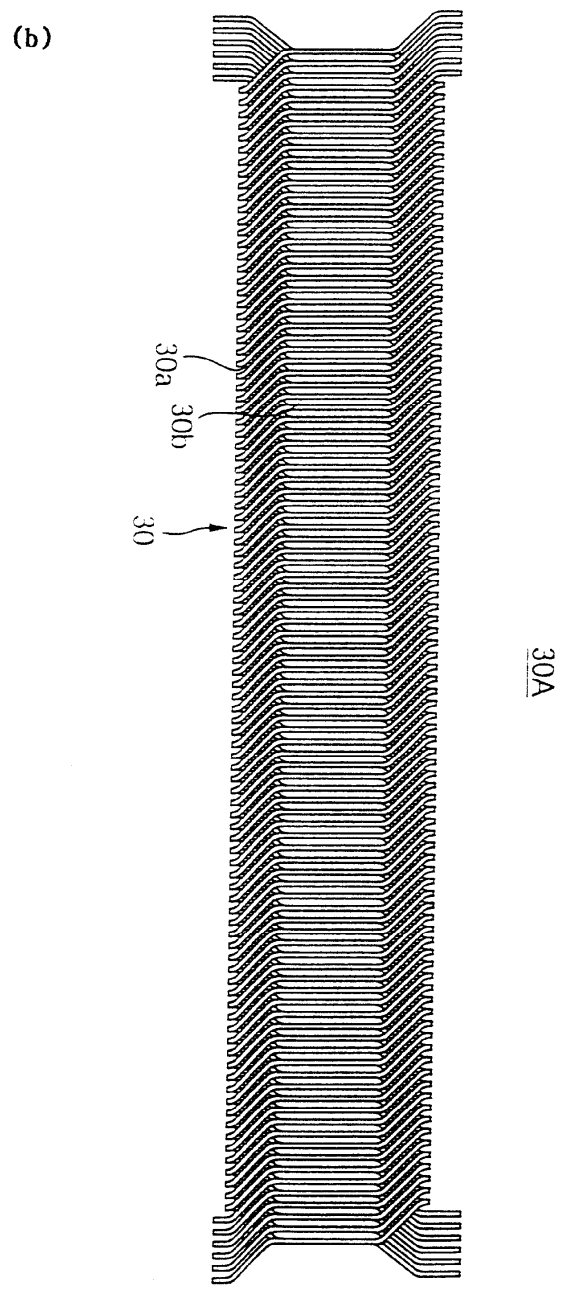
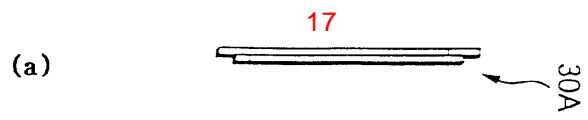

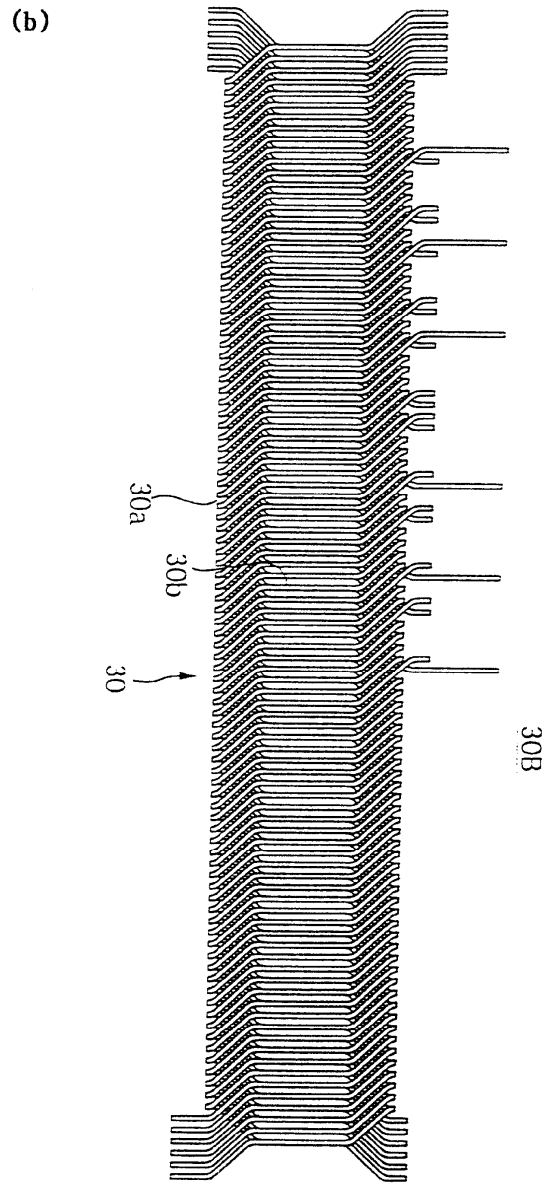
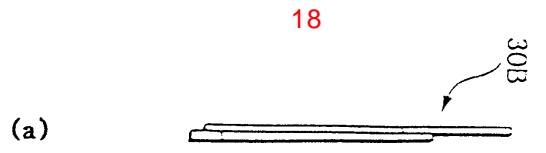

19

