

(No Model.)

2 Sheets—Sheet 1.

J. CORNELIUS. STUMP EXTRACTOR.

No. 393,541.

Patented Nov. 27, 1888.

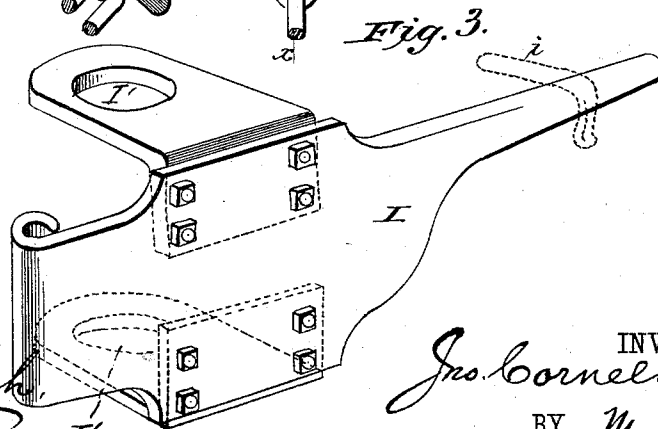
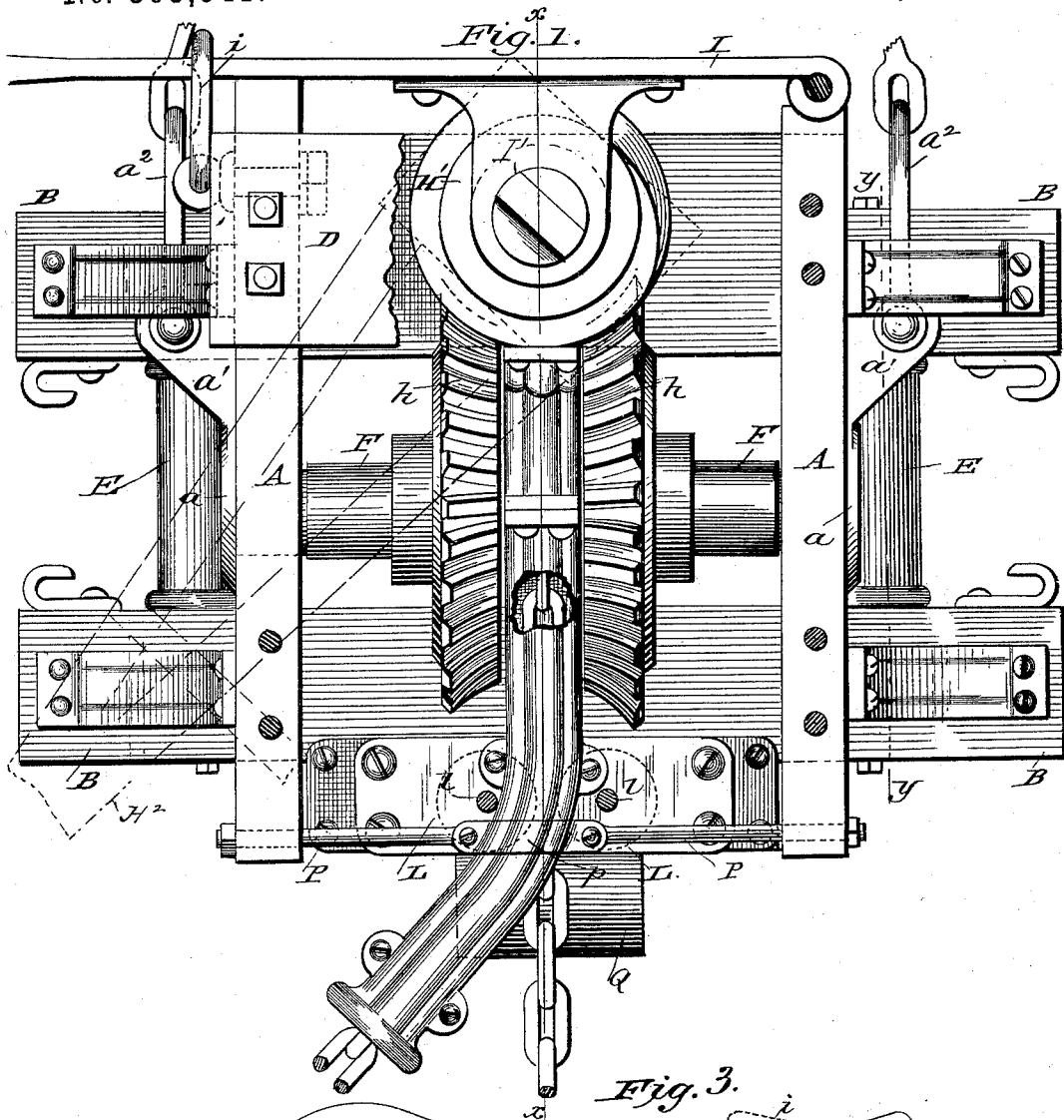

WITNESSES:
Fred G. Dietrich,
P. B. Turpin.

INVENTOR:
Jos. Cornelius,
 BY *Munn & Co*

ATTORNEYS.

J. CORNELIUS.
STUMP EXTRACTOR.

No. 393,541.

Patented Nov. 27, 1888.

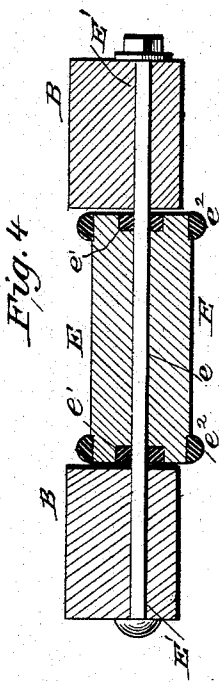

Fig. 4

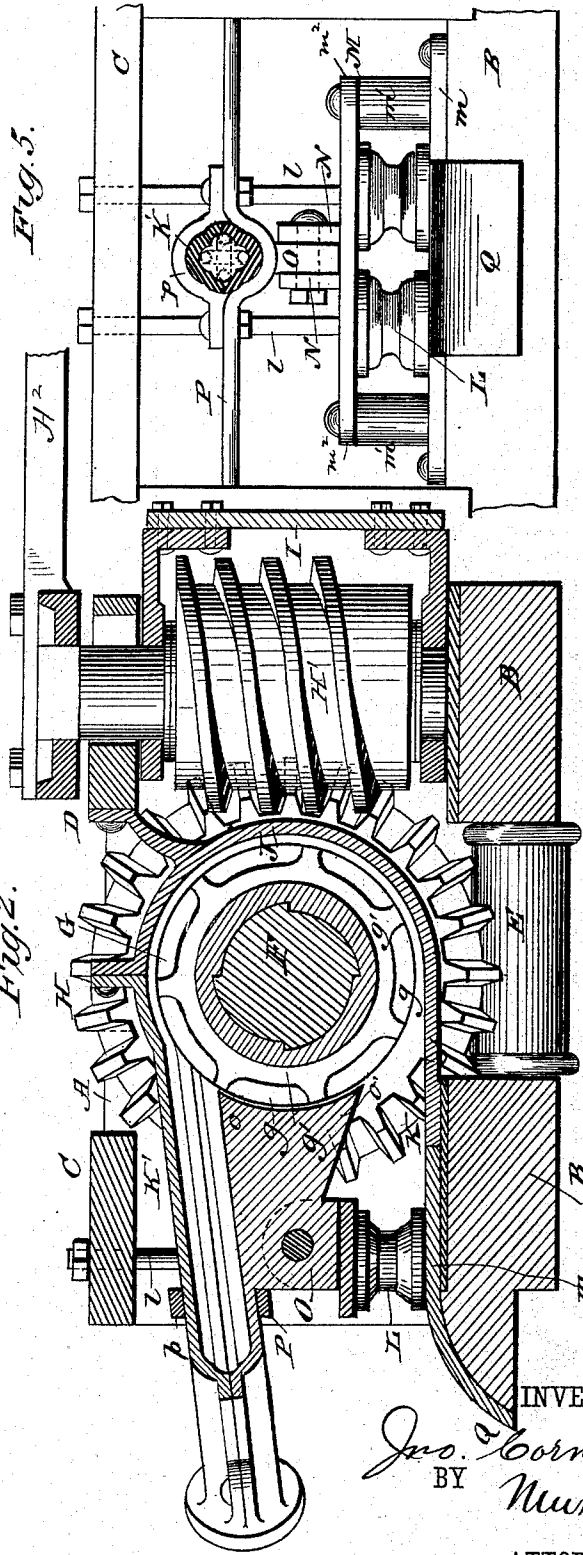

Fig. 5.

Fig. 2.

WITNESSES:
Fred G. Dieterich,
P. B. Surpin.

INVENTOR:
Jos. Cornelius.
 BY *Munn & Co.*
 ATTORNEYS.

UNITED STATES PATENT OFFICE.

JOHN CORNELIUS, OF EVANSVILLE, INDIANA.

STUMP-EXTRACTOR.

SPECIFICATION forming part of Letters Patent No. 393,541, dated November 27, 1888.

Application filed March 1, 1888. Serial No. 265,869. (No model.)

To all whom it may concern.

Be it known that I, JOHN CORNELIUS, of Evansville, in the county of Vanderburg and State of Indiana, have invented a new and useful Improvement in Stump-Extractors, of which the following is a specification.

My invention is an improvement in stump-extractors, and seeks to provide improvements whereby the machine will be strong in operation and easily adjusted in position for use; by which the chain will be accurately guided into the guide-pulleys with its links properly presented to enter between said pulleys in the manner desired; by which the chain when it has been drawn up to the machine in pulling a stump may be quickly adjusted out to position for drawing another stump or stumps, and to so arrange the parts that the power of the operating-worm will be applied on opposite sides of the chain-wheel.

The invention also seeks to provide other improvements; and it consists in certain features of construction and novel combinations of parts, as will be hereinafter described, and pointed out in the claims.

In the drawings, Figure 1 is a plan view of the machine, parts being removed and others shown in section. Fig. 2 is a section of the machine on about line *x x*, Fig. 1. Fig. 3 is a detail view of the worm-supporting lever. Fig. 4 is a detached section on line *y y*, Fig. 1. Fig. 5 is a partial front view of the machine.

In the construction shown the framing consists of the sides *A A*, the runners *B B*, secured below and extended at their ends beyond the said sides, and the front and rear top beams, *C D*.

The runners *B B* are set a considerable distance apart, forming a space between them, in which space I support rollers *E E*, arranged between the runners near their ends and extended slightly below such runners, as shown. These rollers coact with the runners in supporting the machine, so it can be conveniently moved, the rollers on a smooth hard surface bearing the weight of the machine, while on a soft or irregular surface the machine can be easily moved on the rollers and runners. It is preferred to support the roller *E* so the supports therefor will in a measure brace the runners. To this end I form such rollers with

axial openings *e*, and, the rollers being preferably of wood, place metallic bushings *e'* in such openings *e* at the ends of the rollers. I also provide tires or rims *e''*, of metal, encircling the ends of the rollers. The rods *E' E'*, on which the rollers turn, are extended through the runners *B B* and through the openings *e* of the rollers, the said rods being suitably held on the outer sides of said runners, as shown. These rods, it will be seen, in addition to forming bearings for the rollers, serve as braces between the runners and aid in strengthening the machine.

The horizontal or main shaft *F* is supported at its ends in the sides *A*, preferably being journaled in boxes *a*, secured in said sides and having lugs *a'*, to which the anchor-bail *a''* may be connected. On this shaft *F*, I support the chain-wheel *G* and the worm-wheel *H*, which latter is, by preference, formed in two sections, *h*, such sections being arranged on opposite sides of the chain-wheel, and are fixed as to rotary movement with reference to the said chain-wheel. The chain-wheel and sections may be fixed on the main shaft, as shown; but manifestly it would involve no departure from my invention to journal such parts on the shaft. By preference the chain-wheel and worm-wheel are cast or otherwise formed in a single piece, the worm-wheel sections being formed on the opposite sides of the chain-wheel, as shown. By this construction the application of the parts to the shaft is facilitated, the construction of the parts is rendered easier, the accurate relative arrangement of the worm-wheel sections is insured, and the number of parts is reduced, rendering the machine simpler, as will be readily understood.

The chain-wheel and worm-wheel sections form what may be called a "combined worm and chain wheel," the chain-wheel being suitably pocketed at *g* and grooved at *g'* to properly receive and grip the links presented side-wise and edgewise thereto.

The described arrangement of the worm-wheel sections secures an equal distribution of power on opposite sides of the resistance exerted against the chain-wheel and renders the operation of the machine smoother and easier. The worm *H'* is formed and arranged to mesh with the worm-wheel. I support this worm

in bearings I' in lever I, which lever is pivoted or hinged at one end to one side A, and extends at its opposite end to and usually past the opposite side A, and is secured by a suitable fastening, *z*, usually a hook, as shown. By throwing this lever in and out the worm may be thrown into and out of gear with the worm-wheel, so that when the end of the chain has been drawn up to the guide-pulleys in pulling a stump the worm may be thrown out of gear with the worm-wheel and the chain drawn rapidly back through the machine to position for starting another stump.

The arrangement of the lever I shown is very simple and provides a construction which requires but little force or strength to properly move the worm into and out of mesh with the worm-wheel. I prefer to house or case the chain-wheel in at J around its rear side and provide guides or ways K K', leading forward from the under and upper side thereof, through which the chain is directed to and discharged from the machine in the operation of pulling a stump. The lower way, K, leads to the guide-pulleys L, which are supported in a frame, M, consisting of a base-plate, *m*, standards *m'* thereon, and a top plate, *m''*, mounted on said standards and bolted securely thereto, the pulleys being supported between the base and top plates, and being, by preference, journaled on bolt-like rods *l*, which extend between the front runner and front top beam and serve as braces for such parts of the machine.

On the top plate, *m''*, of the pulley-frame M, I cast or otherwise form two upwardly-projected parallel plates, N N, slightly separated to receive between them the plate O, cast on the under side of the guide-tube K', and having its upper and lower rear corners at *o o'* extended into the base-groove of the chain-wheel to strip the chain therefrom in the operation of the machine in either direction—that is to say, in drawing the chain through the machine in pulling a stump or in the reverse direction, as when the chain is being returned through the machine after a stump has been drawn. The lower stripper portion, *o'*, also prevents any crowding and clogging of the chain in case the machine should be turned backward by reversing the movement of the sweep, thus preventing any clogging and the consequent possibility of breaking or damaging the chain or parts of the machine.

The plate O is bolted securely between the plates N, and is thereby held in position, the plate O serving as a support for the upper tube and being extended to form the stripper for clearing the chain from the chain-wheel. When the heavy chain is drawn rapidly through the upper way or guide-tube, K', in returning the chain after a stump has been pulled, there is considerable strain on such tube, to obviate which I provide a cross-brace, P, extended between the sides A, near the forward ends thereof, which brace extends under and supports the tube K', such tube being secured by a cap-piece, *p*, fitted over it and se-

cured at its ends to the body or main portion of the cross-brace. This brace holds the tube K' firmly and enables the same to be made of much lighter metal than would otherwise be practicable.

In order to direct the chain properly to the guide-pulleys, as in taking up slack preparatory to pulling a stump, I provide an inclined platform or bearing-plate, Q, formed, preferably, integral with the lower plate of the pulley-frame and leading up to such pulleys, as shown, in moving up which platform the links will assume the proper position to enable their presentation to the pulleys in the desired manner.

In operation the machine is anchored in position at its rear end, and the chain leading out from the guide-pulleys is secured to one or more stumps, as desired, and power is applied usually by hitching a horse or horses to the sweep secured on the upper end of the worm, the latter being properly meshed with the worm-wheel. Then the machine will be drawn to face the direction of greatest strain, and as one, two, or more stumps of a group are pulled it will from time to time change its position to face the direction of greatest strain, as will be understood from the drawings.

When the stump or stumps are pulled and the chain is drawn up to the guide-pulleys, a horse or horses may be hitched to such end of the chain, the worm be thrown out of mesh with the worm-wheel, and the chain be quickly drawn back through the machine.

A sweep, H², indicated in dotted lines, Fig. 1, and full lines, Fig. 2, forms a convenient means of applying the moving force to the worm.

Having thus described my invention, what I claim as new is—

1. In a stump-puller, the combination of the chain-wheel, the worm-wheel formed in sections and having such sections arranged on opposite sides of such chain-wheel, the worm fitted to mesh with said sections, and suitable supporting-framing, substantially as set forth.

2. In a stump-puller, the combination of the framing having sides A A, the main shaft, a worm-wheel and chain-wheel thereon, a worm fitted to mesh with such worm-wheel, a lever provided with bearings for such worm and hinged at one end to one of the sides A and extended at its opposite end to the other side A, and a fastening for securing such end of the lever to said side, substantially as and for the purposes specified.

3. In a stump-puller, the combination of the framing, the main shaft supported therein, the combined worm-wheel and chain-wheel supported on said shaft and formed in a single piece, the worm-wheel being formed in sections arranged on opposite sides of the chain-wheel, and the worm meshing with both such sections of the worm-wheel, substantially as set forth.

4. In a stump-puller, the combination, with the framing having runners set apart, substan-

tially as described, of rollers journaled between said runners, near the ends thereof, and projected slightly below said runners, substantially as set forth.

5 5. In a stump-puller, the main framing having runners set apart, substantially as described, combined with rollers arranged between said runners and having axial openings formed through them, and rods extended through said
10 runners and through the axial openings and secured, forming axles for the rollers, and braces between the runners, substantially as and for the purposes specified.

15 6. In a stump-puller, the combination of the framing, the chain-wheel, the discharge-tube leading therefrom, through which the chain may be discharged, and the cross-brace secured to and bracing said discharge-tube, the said cross-brace being extended laterally from
20 the discharge-tube, substantially as set forth.

25 7. The combination of the main frame, the pulley-frame having upwardly-projected plate N, the chain-wheel, and the discharge-tube provided with a plate, O, such plate being fitted
30 and secured between the plates N, and having upper and lower portions, *o o'*, extended into the groove of the chain-wheel, whereby to strip the chain from said wheel in either direction of movement of the latter, substantially as set
35 forth.

8. In a stump-puller, the combination of the main frame, the chain-wheel, the pulley-frame having its top plate provided with upwardly-projected plates N, and the plate O, fitted and
35 secured between said plates N and formed with stripping portions *o o'*, extended into the

base-groove of the chain-wheel, all substantially as and for the purposes specified.

9. In a stump-puller, substantially as herein described, the combination of the framing, the
40 chain-wheel, the guide-pulleys, the pulley-frame formed of a base-plate having an inclined plate or platform, Q, projected forward from it, and a top plate having upwardly-projected plates N N, separated as described, and
45 the discharge guide or tube having the depending plate O, secured between said plates N, and formed with upper and lower portions, *o o'*, projected into the base-groove of the chain-pulley, substantially as and for the purposes
50 specified.

10. The improvement in stump-pullers herein described and shown, consisting of the main frame, the main shaft supported therein,
55 the chain-wheel supported on said shaft, the worm-wheel formed in sections arranged on opposite sides of the chain-wheel, the worm arranged to mesh with both sections of the worm-wheel, the lever hinged at one end to the main
60 frame and provided between its ends with bearings for the worm, whereby the worm may be adjusted into and out of mesh with the worm-wheel sections, a fastening for securing such lever with the worm in mesh, and guides
65 for the chain, through which guides the chain may be directed to and discharged from the chain-wheel, substantially as and for the purposes specified.

JOHN CORNELIUS.

Witnesses:

P. B. TURPIN,
SOLON C. KEMON.