

(43) Date of A Publication 15.12.1999

(21) Application No 9812750.9

(22) Date of Filing 13.06.1998

(71) Applicant(s)
Magna Seating Systems Limited
(Incorporated in the United Kingdom)
Newmanleys Road, New Eastwood, NOTTINGHAM,
NG16 3JG, United Kingdom

(72) Inventor(s)
Francis Edward Craig
Robert Walkley

(74) Agent and/or Address for Service
Eric Potter Clarkson
Park View House, 58 The Ropewalk, NOTTINGHAM,
NG1 5DD, United Kingdom

(51) INT CL⁶
B60N 2/26

(52) UK CL (Edition Q)
A4L LAL LBEQ LCC LC15 LC31 LC5 LC54 LC55 LC56
L108 L109

(56) Documents Cited
GB 2297479 A GB 2207043 A WO 96/01748 A1
US 5538319 A US 5183312 A US 5098157 A
US 5083837 A US 4762364 A

(58) Field of Search
UK CL (Edition P) **A4L LAAR LAL LBEJ LBEP LBEQ**
LCC
INT CL⁶ **B60N 2/14 2/26 2/28 2/30**
On-line: **WPI, Patents Citation Index**

(54) Abstract Title
Child and baby seat for a vehicle

(57) A child seating unit a vehicle is adaptable for use as a baby seat 10 in a rear facing direction, and a child seat 10 in either forward or rear facing direction. The unit includes a seat 10 comprising a squab portion 12 and a cushion portion 11 for supporting an occupant of the seating unit; a base module 2 for supporting the seat 10 in the vehicle and providing swivel means 6 to allow the seat to rotate between a forward facing condition and a rearward facing condition and tilt means (32-36, Fig. 4) for rotating the seat about a horizontal axis between a normal seating condition and a reclined condition. A canopy (7, Figs 8 and 9) for head protection extends from a top portion of the squab, and a rising head rest (13, Figs 8 and 9) includes seat belt guides (131, 132, Figs 8 and 9) for correctly positioning the belt (138, 139, Fig 11) in relation to the occupant. Side bolsters arranged in pairs 14, 15 and 16, 17 may be moved in concert to adjust the width of seat 10. Preferably the seat 10 is fixed to the floor of the vehicle by means 3.

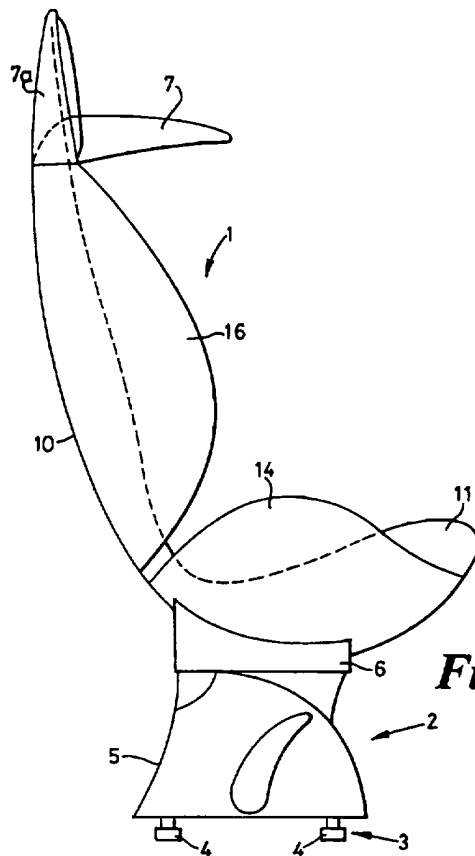

Fig. 2

GB 2 338 181 A

1/9

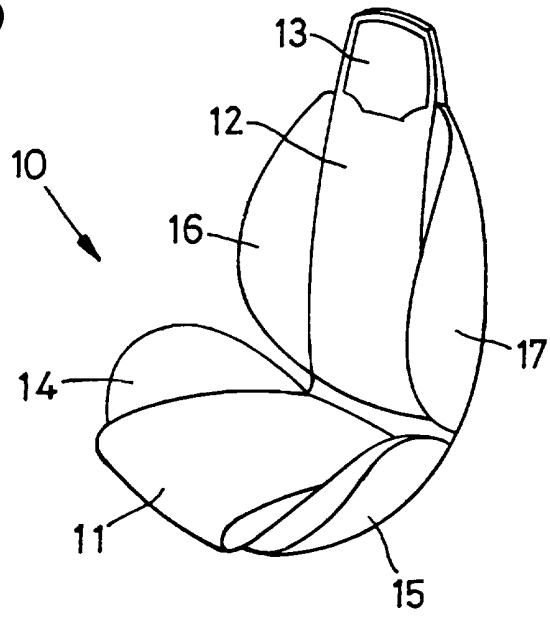
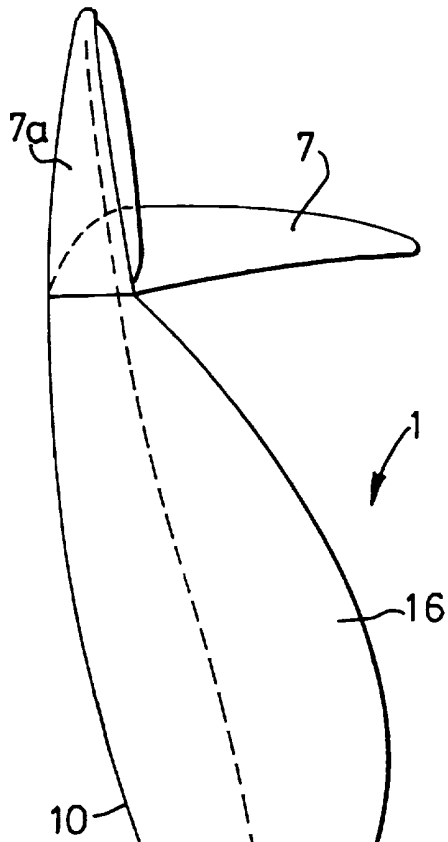

Fig. 1

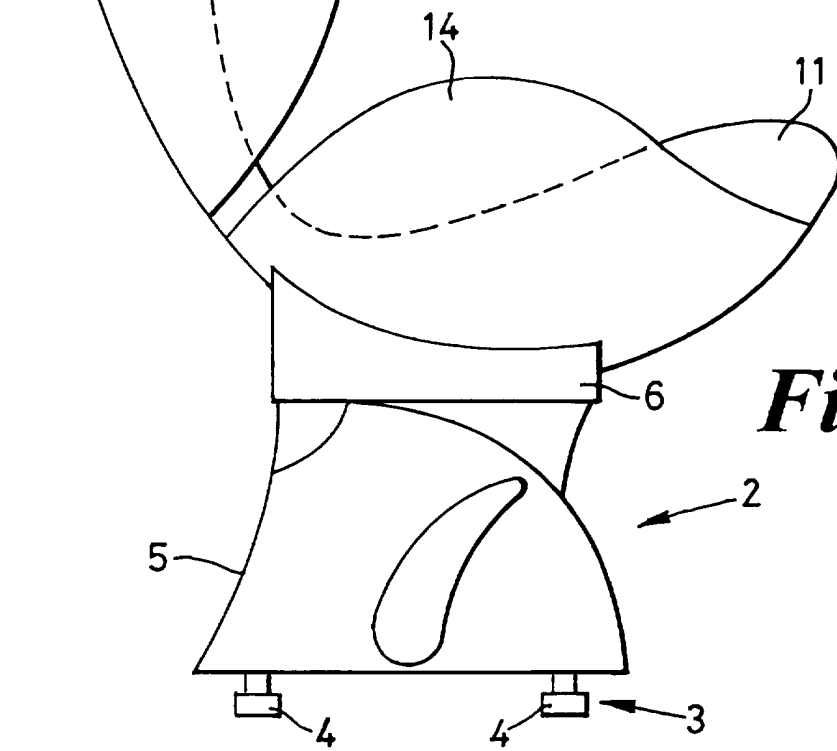
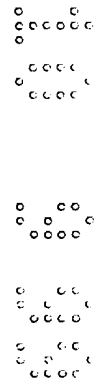

Fig. 2



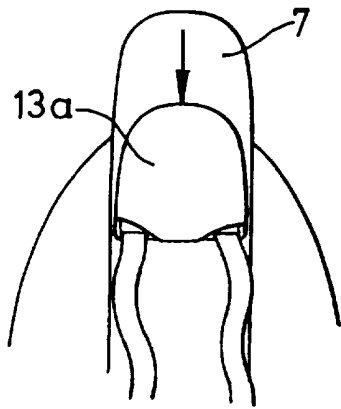

Fig. 3a

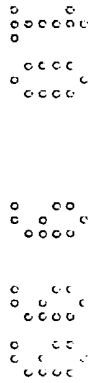
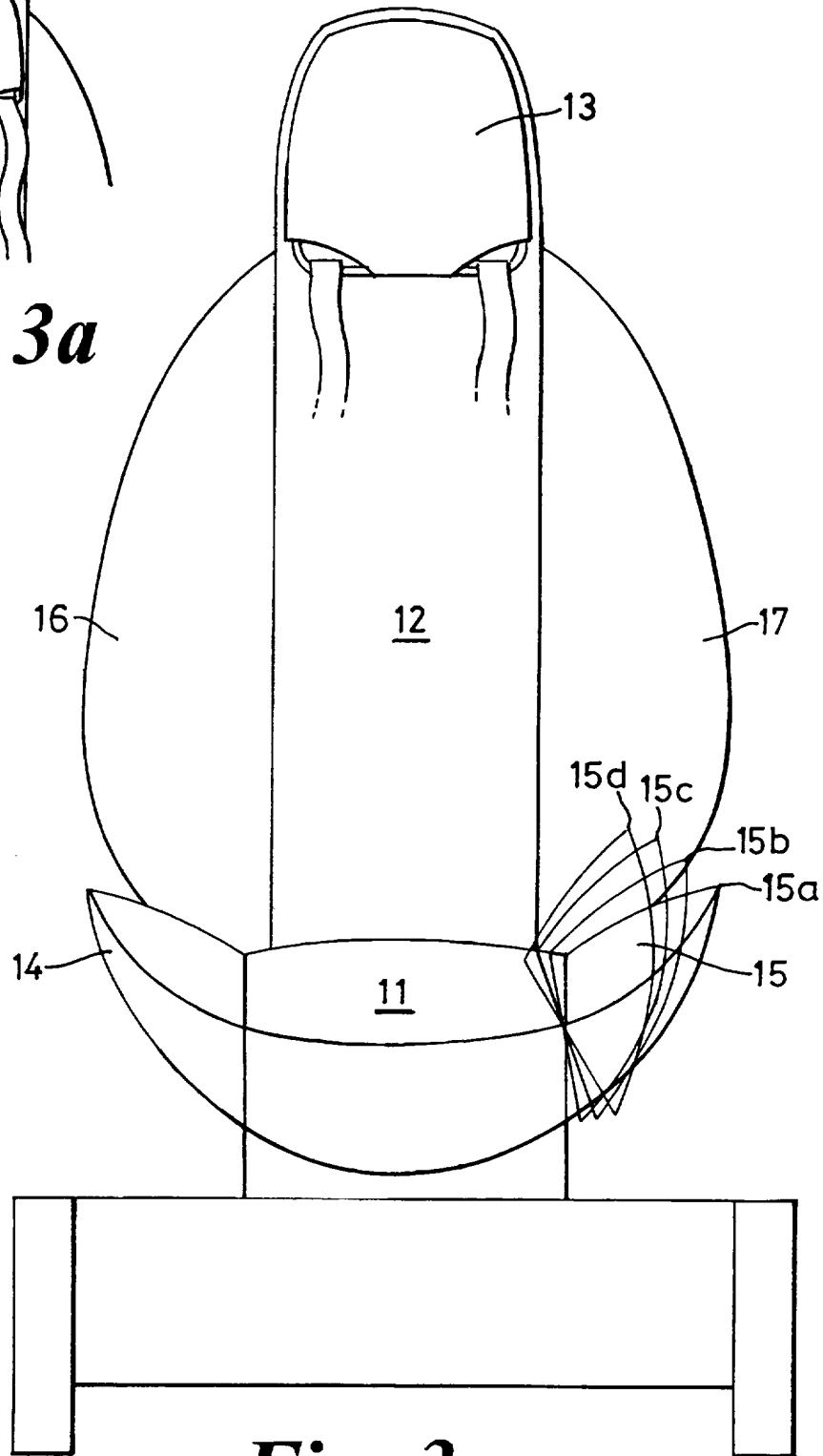

Fig. 3

3/9

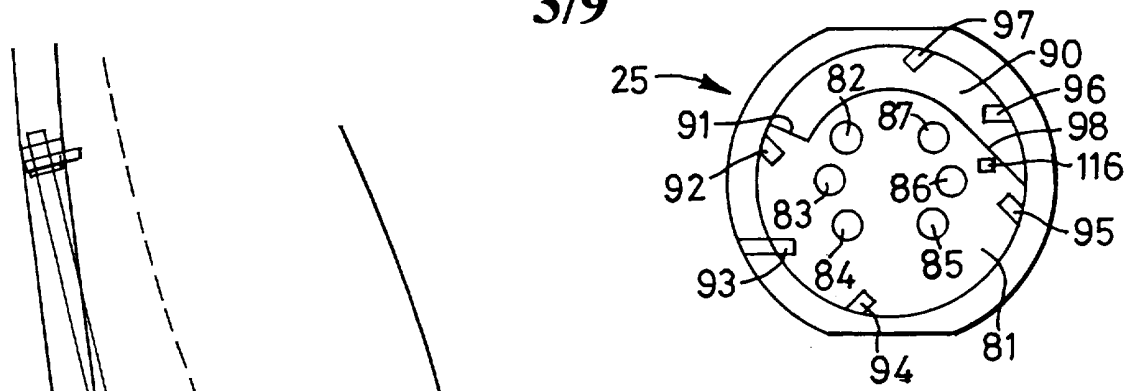

Fig. 6

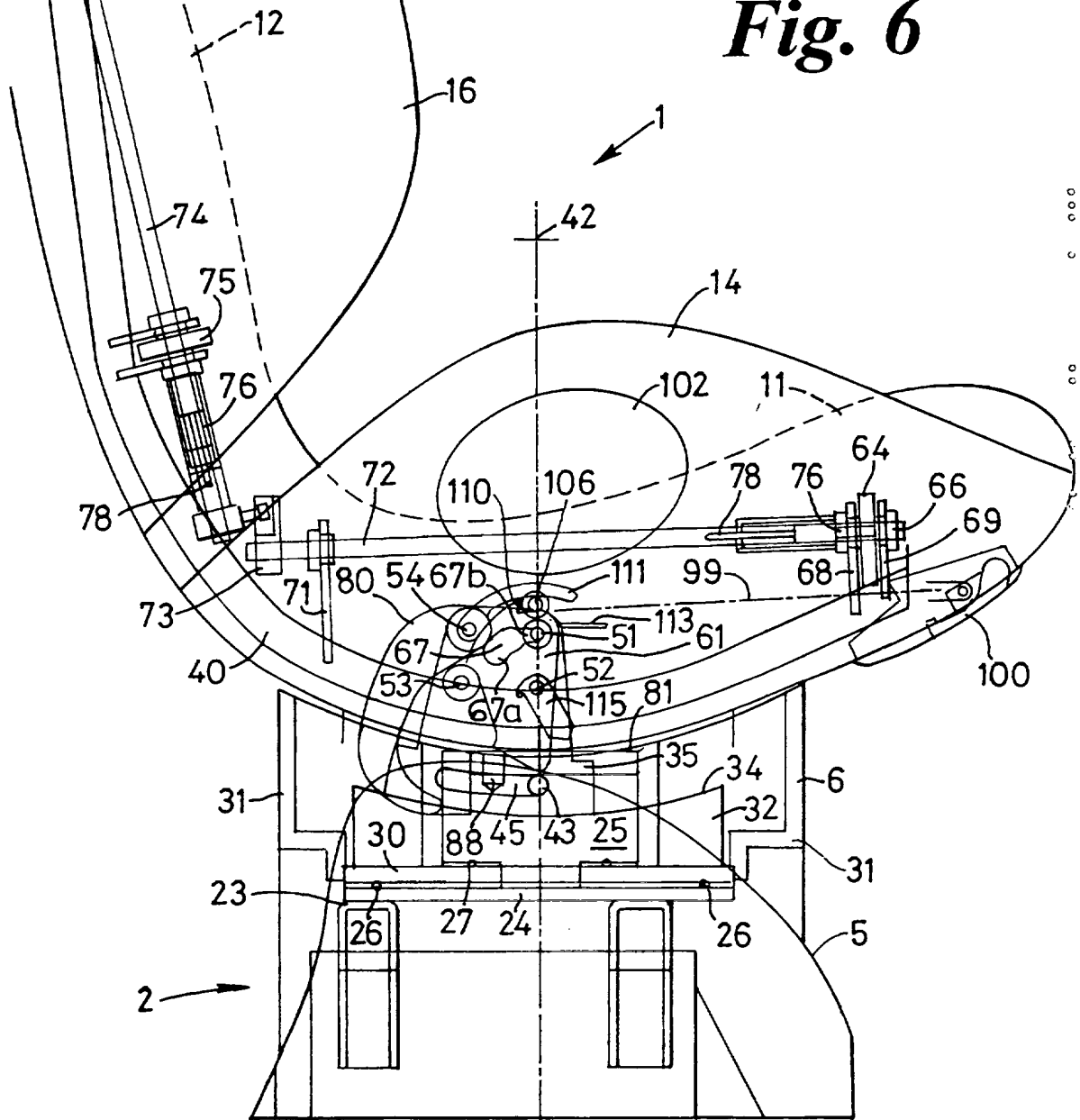

Fig. 4

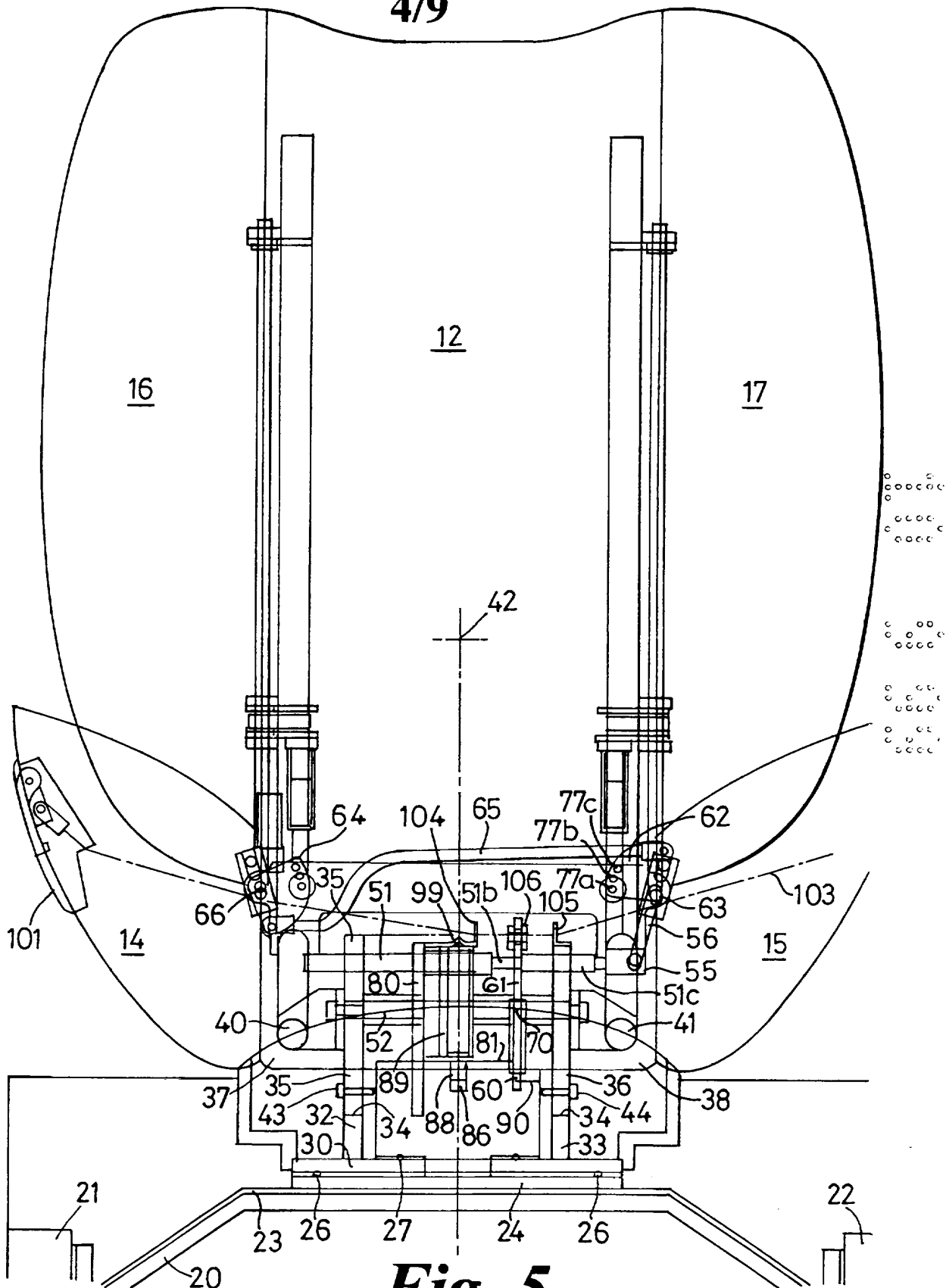

Fig. 5

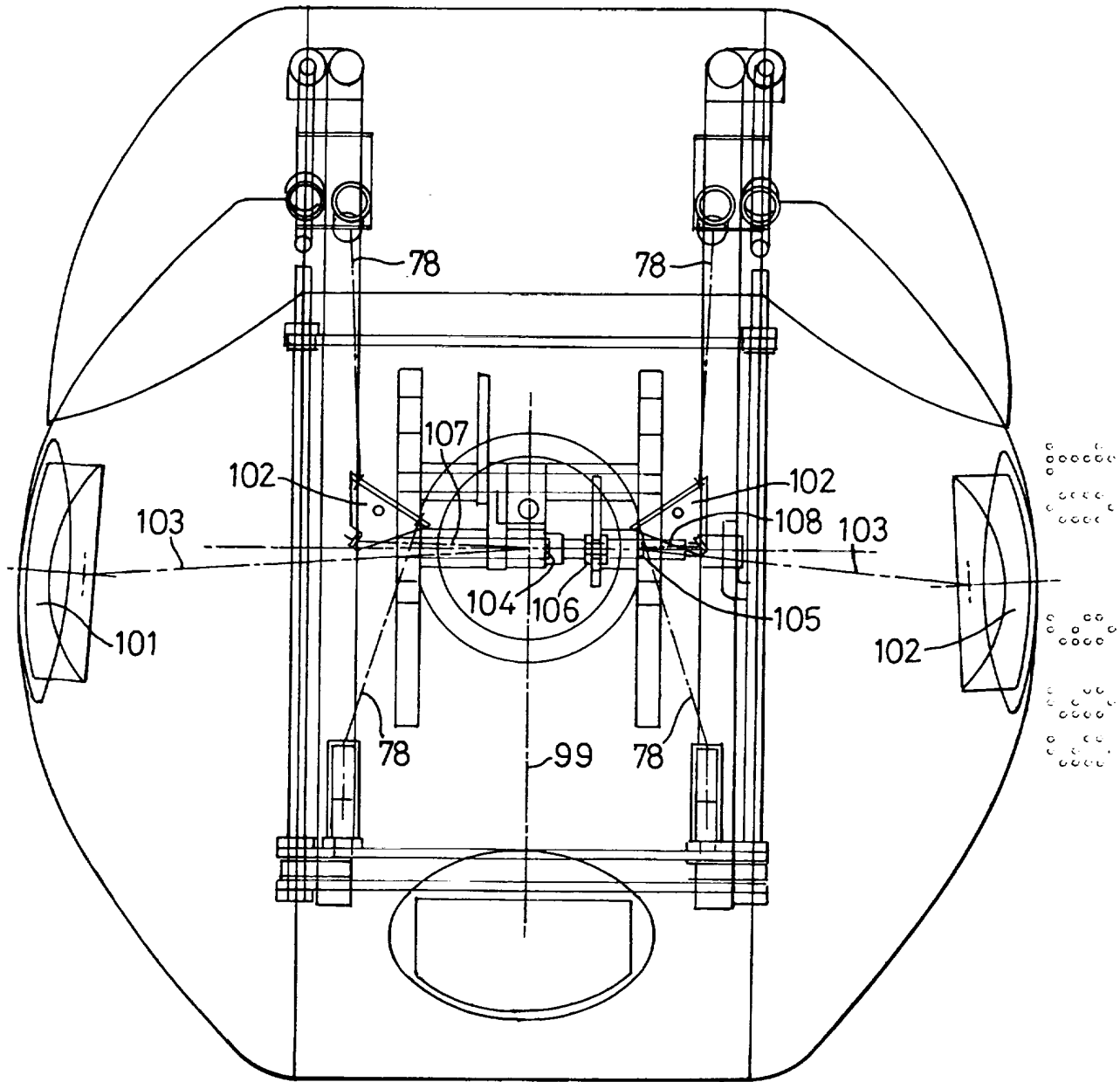

Fig. 7

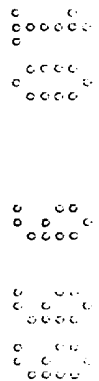
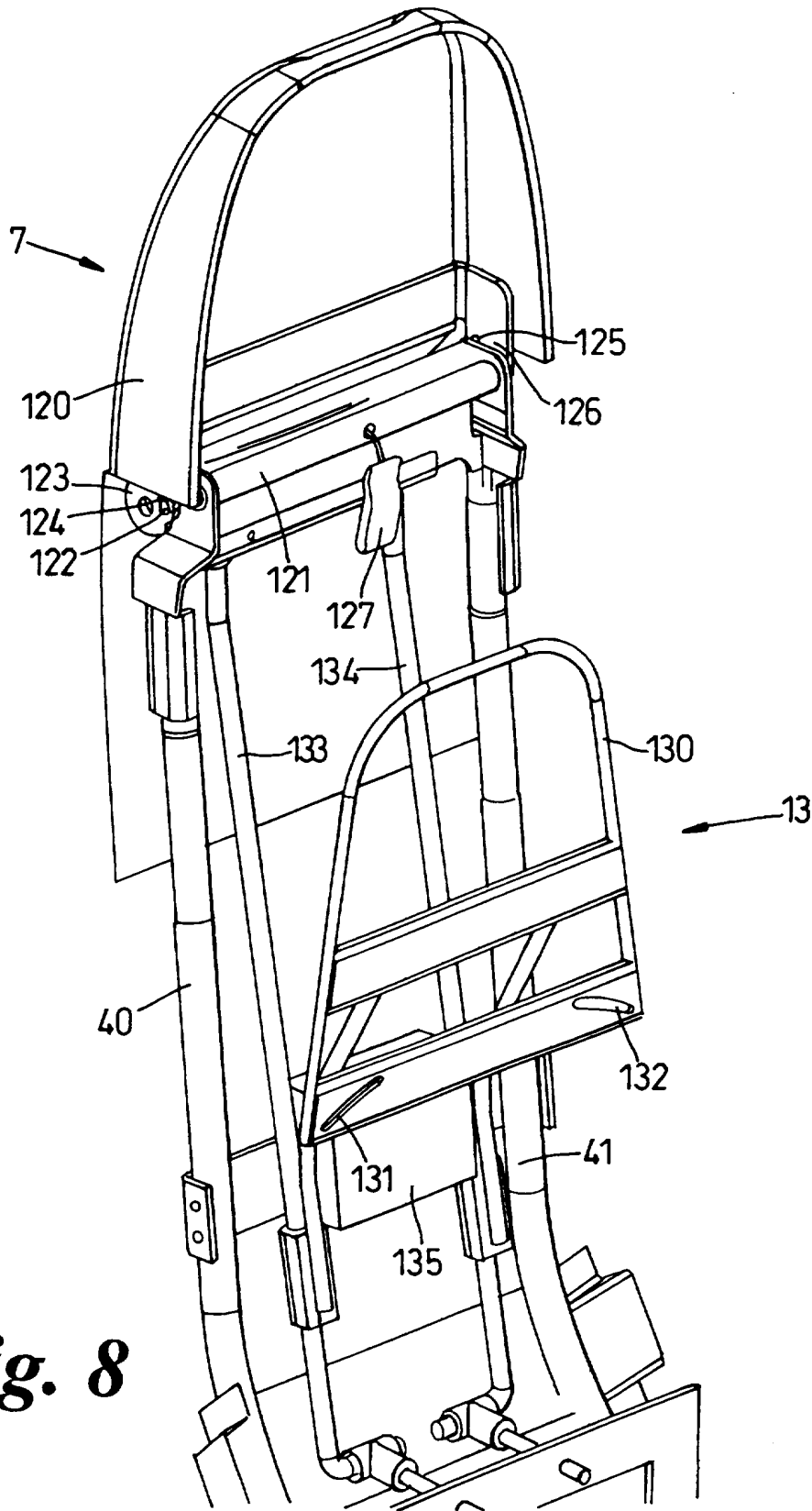

Fig. 8

7/9

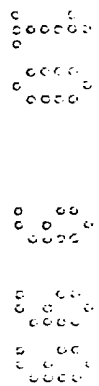
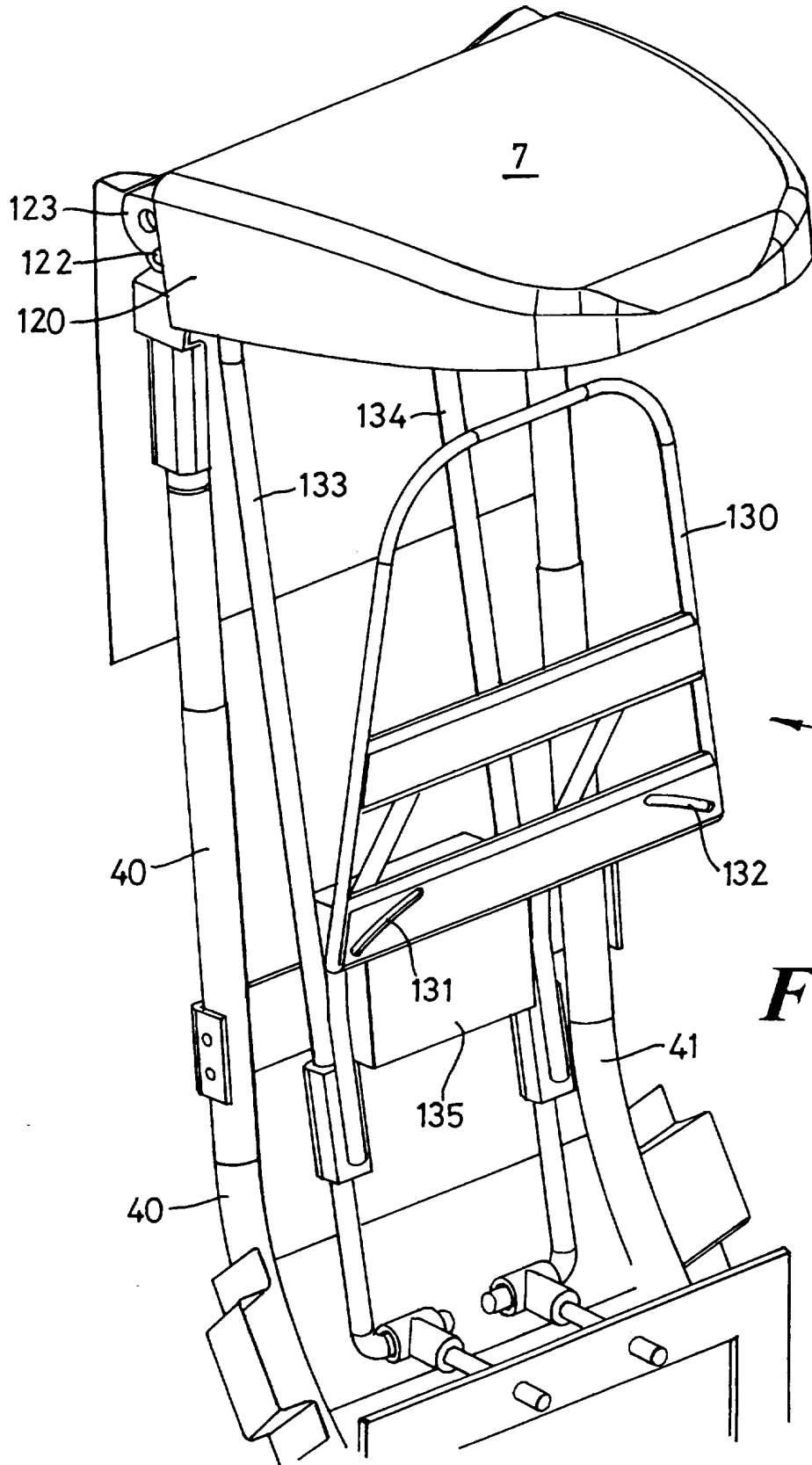

Fig. 9

8/9

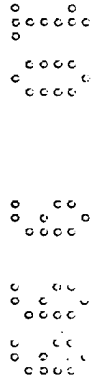
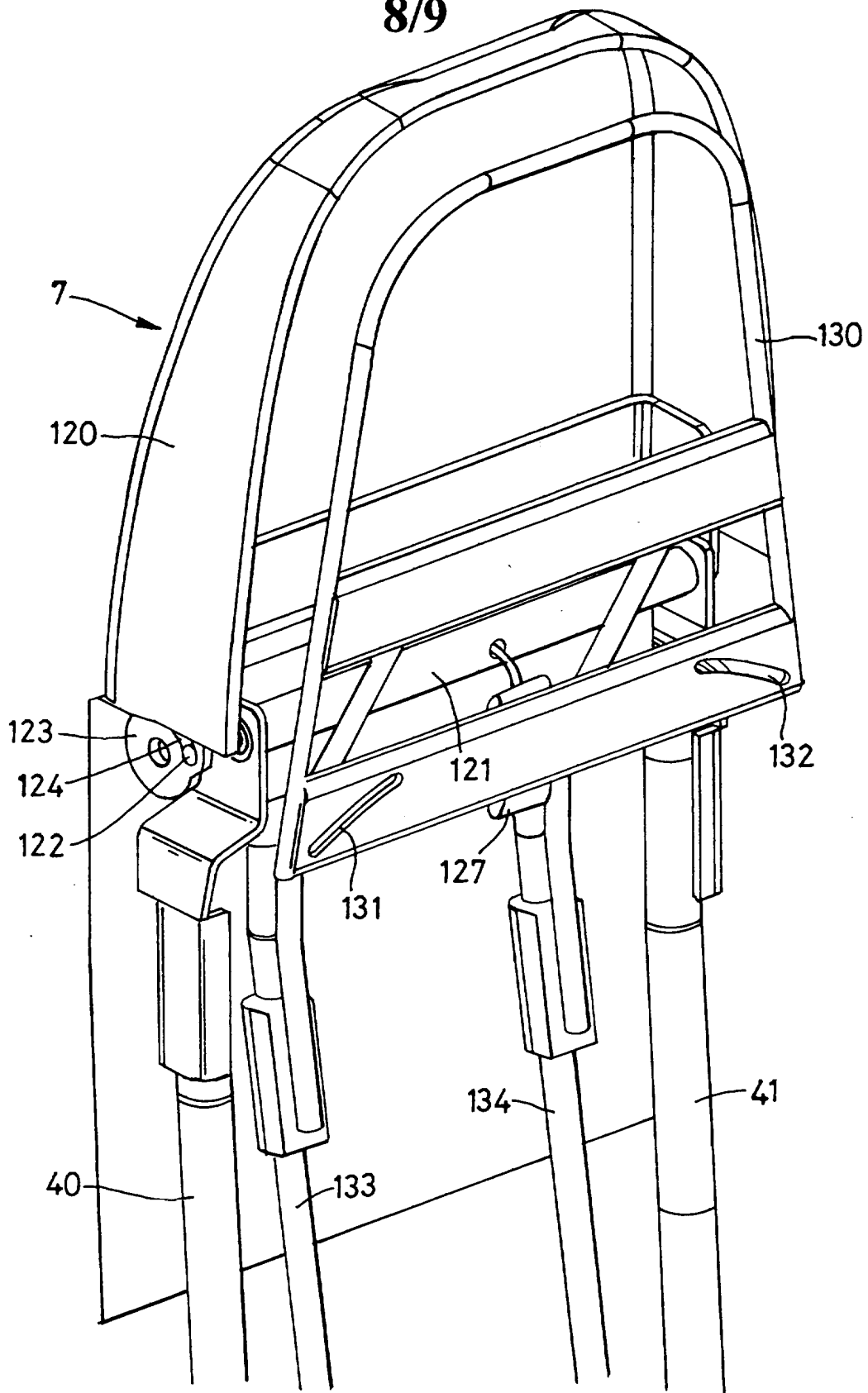

Fig. 10

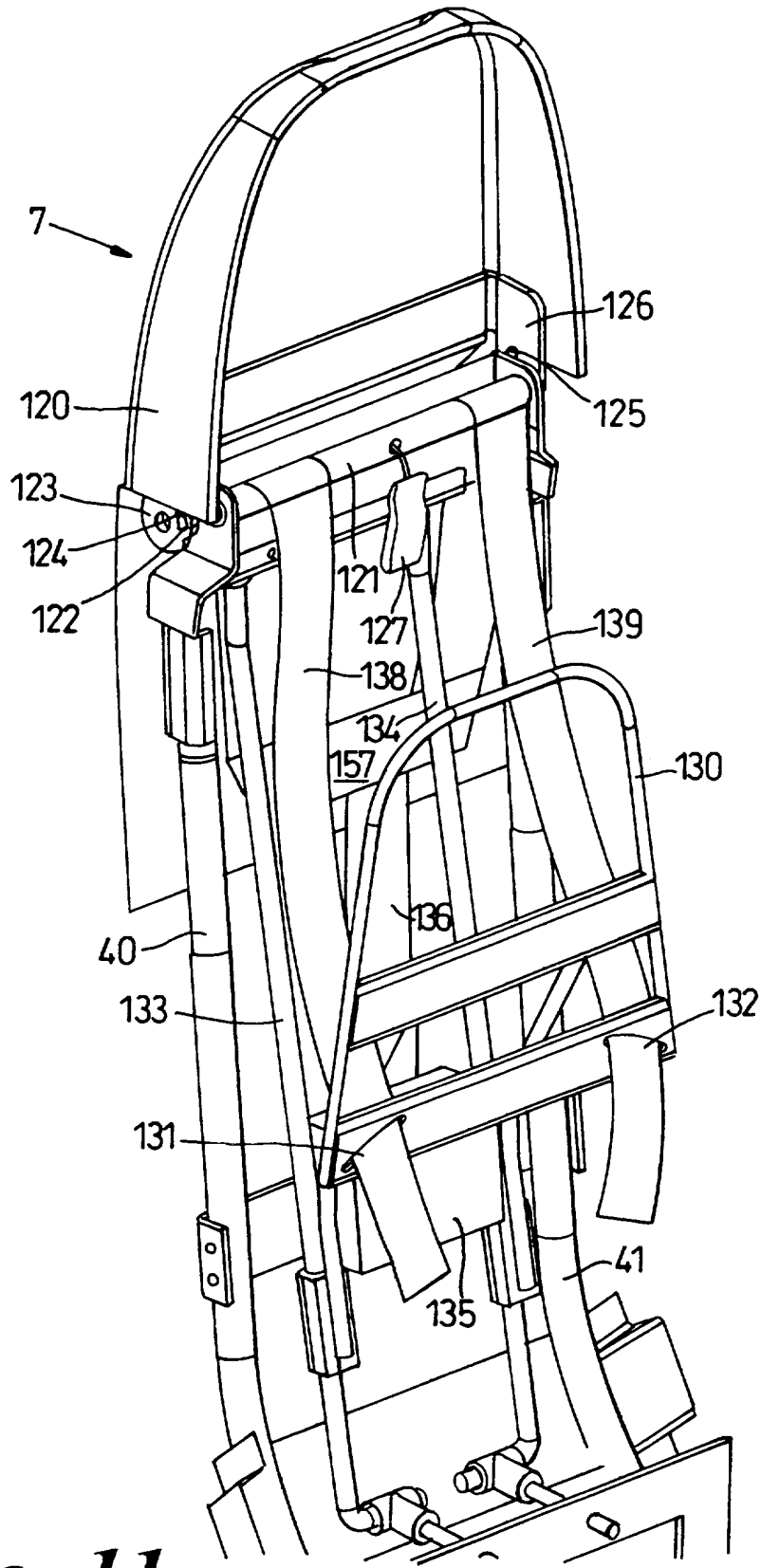
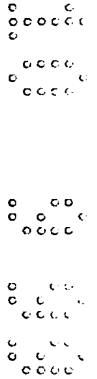

Fig. 11



CHILD AND BABY SEAT FOR A VEHICLE

The present invention relates to child and baby seats for vehicles, and in particular to a child and/or baby seat which can be adapted to both
5 forward and rearward facing orientations.

There are many designs of child and baby seats or carriers for vehicles which are adapted to be strapped into or onto existing adult vehicle seats. However, recently there has been much interest in providing customised
10 seats for children which are directly fitted to the vehicle body, eg. the floor. This is particularly so in vehicles offering flexible seating arrangements in which seats can readily be inserted and removed from the vehicle.

15 Such customised seats directly fitted to the vehicle floor can offer a greater degree of security against injury of the occupant than some carriers which are secured to an adult seat using existing seat belts, for example, where there is a risk of inadvertent incorrect fitting or usage.

20 The present invention seeks to provide a vehicle seat, for connection to the vehicle floor, which is adaptable for use both by a child and a baby. The present invention also seeks to provide such a seat which may be deployed in both forward and rearward facing arrangements, and which provides a high degree of security for its occupant.

25

The present invention also seeks to provide a child seat for a vehicle with head restraint and integral seat belt which is adaptable to suit a variety of occupant sizes.

According to one aspect, the present invention provides a child seating unit for a vehicle, including:

a seat comprising a squab portion and a cushion portion for supporting an occupant of the seating unit;

5 a base module for supporting the seat;

means for connecting the seating unit to the vehicle floor;

the base module including swivel means to allow the seat to rotate between a forward facing condition and a rearward facing condition while the seat is connected to the vehicle floor.

10

According to a further aspect, the present invention provides a child seat for a vehicle, including:

a squab portion and a cushion portion for supporting an occupant of the seat;

15 means for connecting the seat to the vehicle;

wherein the squab portion further includes a head restraint support frame mounted thereon, substantially parallel thereto, adapted to be slidable between an upper position above the squab portion to a lower position in front of, and part way down, the front of the squab portion.

20

According to a further aspect, the present invention provides a child seat for a vehicle, including:

a squab portion and a cushion portion for supporting an occupant of the seat;

25 means for connecting the seat to the vehicle;

wherein the squab portion further includes a folding canopy adapted to fold from an upright position above the squab portion and substantially co-planar therewith when not deployed, to a deployed

condition in which it extends forward of the squab portion substantially orthogonal thereto.

Embodiments of the present invention will now be described by way of example and with reference to the accompanying drawings in which:

Figure 1 shows a perspective view of the seat portion of a child seating unit according to the present invention;

Figure 2 shows a side view of the seat of figure 1, including a base module;

Figure 3 shows a front view of the seat of figure 2, with figure 3a showing detail of an alternative position of the head restraint;

Figure 4 shows a schematic side view of the seating unit of figure 2, including a base module and detail of the control mechanism;

Figure 5 shows a schematic front view of the seating unit of figure 4;

Figure 6 shows a schematic plan view of a central spigot of the seating unit of figures 4 and 5;

Figure 7 shows a schematic plan view of the seating unit of figures 4 and 5;

Figure 8 shows a perspective view of a head restraint and canopy assembly for use on the seating unit of figure 1, with head restraint in lowered position and canopy not deployed;

Figure 9 shows a perspective view of the assembly of figure 8 with head restraint in lowered position and canopy deployed;

Figure 10 shows a perspective view of the assembly of figure 8 with head restraint in the higher position; and

Figure 11 shows a perspective view of the assembly of figure 8 showing additional detail of a seat belt mechanism.

With reference now to figure 1, a child seating unit for a vehicle includes a seat 10 which comprises a cushion portion 11 (hereinafter also "cushion"), a squab portion 12 (hereinafter also "squab") and a head restraint 13.

5

A pair of side bolsters 14, 15 are provided along lateral edges of the cushion. A pair of side bolsters 16, 17 are provided along lateral edges of the squab. The cushion 11, squab 12, and side bolsters 14-17 are preferably formed of any suitable material, for example, carbon fibre, shaped and upholstered as required for comfort and safety.

10

With reference to figure 2, the seating unit 1, incorporating the seat 10, is mounted onto a base module 2 which includes a floor engaging mechanism 3 for removably installing the seating unit into a vehicle.

15

Preferably, the floor engaging mechanism 3 includes a set of floor latch rods 4 which engage with tracks in the vehicle floor, as described in detail in co-pending UK patent application no. 98121247, entitled "Track-based seating for a vehicle". However, it will be understood that any suitable mechanism may be used to secure the seating unit within the vehicle.

20

The base module 2 includes a fixed portion 5, which is in fixed relation to the vehicle floor, and a swivel portion 6, on which the seat 10 is mounted, which is able to rotate about a vertical axis so that the seat 10 can be moved to be forward or rearward facing within the vehicle without disconnecting the seat from the vehicle floor.

25

The seat is preferably also provided with a plurality of intermediate swivel lock positions between the forward and rearward facing conditions, so that

a user of the vehicle may easily reach in and install a baby or child in the seat through a side door of the vehicle. Preferably, the swivel lock positions are 0° , $\pm 45^\circ$, $\pm 135^\circ$ and 180° positions where 0° is the forward facing condition, 180° is the rearward facing condition, the others being
5 intermediate swivel lock positions.

Throughout the present specification, the terms forward, rearward, up, down, horizontal and vertical and other similar terms are used in the context of a customary installation of the seating unit within a vehicle.
10 The terms “left” and “right” are used to denote left and right hand sides of the seat as viewed by an occupant of the seat.

The seating unit is particularly adapted to be usable as a baby seat in a rearward facing configuration and reclined from the position shown in
15 figure 2. The seating unit is also adapted to be used as a child seat for larger children in either a forward or rearward facing configuration in the upright or “normal” configuration of figure 2, or in the reclined position referred to above.

20 The seating unit 1 also includes a canopy 7 which is adapted to fold from an upright storage condition indicated at 7a, in which it is above and substantially co-planar with the squab portion 12, to a deployed condition indicated at 7, in which it extends substantially orthogonal to, ie. forward of and above, the squab portion 12. The canopy 7, in the deployed
25 condition, is preferably used when the seating unit is in the baby seat (rearward facing, reclined) position as a measure of protection against falling glass or other debris in the event of a vehicle collision.

With reference to figure 3, the side bolsters 14-17 of both the squab and cushion are adapted to move between a wide configuration depicted by 15a, through a series of positions (eg. 15b, 15c) to a narrow configuration 15d. The wide configuration is suitable for larger children, and the narrower configurations are suitable for smaller children and infants or babies.

The cushion side bolsters 14, 15 are preferably hinged to the cushion 11 along an axis substantially parallel to the cushion 11, while the squab side bolsters 16, 17 are preferably hinged to the squab 12 along an axis substantially parallel to the squab 12.

Preferably, all four side bolsters 14-17 move in concert with one another between wide and narrow configurations, for example using a mechanism to be described hereinafter.

The seating unit preferably also includes a head restraint 13 which is displaceable from an upper position above and substantially parallel to the squab 12 as shown in the main part of figure 3, to a lower position 13a in front of, substantially parallel with and part way down the front of the squab 12, as shown in figure 3a. Intermediate positions between the upper and lower positions are also possible.

With reference to figures 4 and 5, details of the base module 2 will now be described. The seating unit 1 is adapted to be connected to a vehicle floor using latching points corresponding to a standard width adult seat. Thus, the base module 2 includes a bridge 20 extending between two floor latching mechanisms 21, 22. An upper surface 23 of the bridge 20 supports a fixed plate 24 coupled thereto. Rigidly connected to the fixed

plate 24 is a central spigot 25 about which the seat 10 rotates. Rotatably mounted onto the fixed plate 24, by way of ball bearing race 26 is a rotating plate 30 which is retained in the horizontal plane by a second ball bearing race 27 adjacent to a lower surface of the spigot 25.

5

Extending upwardly from the rotating plate 30 is a circular cylindrical side wall 31, and a pair of tilt mechanism support walls 32, 33, each of which has an upper surface 34 profile (best seen in figure 4) which is curved to correspond with an arc of a swinging stand 35 on the right hand side of the seat and a corresponding swinging stand 36 on the left hand side of the seat.

10

The swinging stands 35, 36 each include a corresponding side arm 37, 38 onto which is clamped a tubular support member 40, 41 corresponding to the right and left sides of the seat, respectively.

15

The tubular support members 40, 41 provide the basis of a framework which supports the cushion 11, squab 12, head restraint 13, and side bolsters 14-17. The seat may be moved from a normal seating condition, as depicted in figure 4, to a reclined condition in which the seat is tilted backwards about a reference point axis 42 by sliding the swinging stands 35, 36 along the upper surfaces 34 of the tilt mechanism support walls 32, 33. The swinging stands, and therefore the seat 10, are limited in their movement between normal and reclined condition by a pair of pins 43, 44 which pass through corresponding arcuate swinging stand slots 45 (only the right hand side shown). The pair of pins 43, 44 are also operative to retain the swinging stands 35, 36, and thereby the entire seat 10 assembly, engaged on the support walls 32, 33.

20

25

Extending across between the swinging stands 35, 36 are first, second, third and fourth pins, respectively numbered 51, 52, 53, 54, as shown in figure 4.

5

The first pin 51 is a control pin for the side bolster movement, and passes through (from left to right as viewed in figure 5) the right side swinging stand 35, a control plate 61, and the left side swinging stand 36. The side bolster control pin 51 then terminates in a head 55 which provides a pivoting connection to a link member 56 which drives a left cushion bolster cam 62 which pivots about an axis 63. Left cushion bolster cam 62 is connected to a right cushion bolster cam 64 by a control rod 65. The right cushion bolster cam 64 pivots about an axis 66. Cams 62, 64 are secured to the respective tubular support members 41, 40 by means of brackets 68, 69 (front) and 71 (rear). Cams 62 and 64 are coupled to drive left and right bolsters correspondingly, in opposite directions in concert with one another, between the wide 15a and narrow 15d configurations.

20 Bolster control pin 51 includes a first section 51a of first diameter, a second section 51b of second, smaller diameter, and a third section 51c of diameter equal to the first section and is axially moveable to correspond to movement of the bolsters. Control pin 51 passes through a slot 67 in the control plate, which slot 67 includes an arcuate, large width portion 67a and an arcuate small width portion 67b. The second section 51b of the
25 bolster control pin can pass through either portion 67a or 67b; however, the first section 51a is precluded from moving through the small width portion 67b. Bolster control pin 51 is biased to the right as viewed in figure 5.

The second pin 52, also connecting right and left swinging stands 35, 36 provides a pivot point 70 for the control plate 61.

5 The third pin 53, also connecting right and left swinging stands 35, 36 acts as a stop to the rotation of the control plate 61 in both clockwise and anticlockwise directions about its pivot, pin 52.

10 The fourth pin 54, also connecting right and left swinging stands 35, 36 acts as a pivot about which a restraining finger 80 can rotate. As viewed in figure 4, the restraining finger extends down to the central spigot to engage therewith in a manner to be described later. The restraining finger is biased towards the central spigot, ie. in an anticlockwise direction as viewed in figure 4.

15

With reference to figure 6, the central spigot 25 comprises a flat upper surface 81 into which are formed six holes 82-87 each adapted to receive a plunger 88 (figure 4). The hole selected by the plunger depends upon which position the seat is turned to, and the angle of tilt of the seat. In the preferred embodiment, each hole is drilled approximately 5 degrees to the direction normal to the upper surface 81, thereby accommodating a 10 degree tilt of seat. It will be understood, however, that the positioning and angle of these holes 82, 87 may be varied to accommodate different tilt angles of the seat, if required.

25

In figure 6, the left hand side of the central spigot 25 is rearmost with respect to the seat, and the right hand side is foremost. Hole 83 corresponds to the plunger 88 position when the seat 10 is turned to forward facing condition, holes 82, 84 corresponding to the plunger 88

position when the seat 10 is turned to $\pm 45^\circ$ from the forward facing condition, all when the seat is in normal or upright condition.

Hole 86 corresponds to the plunger 88 position when the seat 10 is turned
5 to an upright rearward facing condition, holes 85, 87 corresponding to the
plunger 88 position when the seat 10 is turned to $\pm 45^\circ$ from the upright
rearward facing condition. Holes 82, 83, 84 correspond to respective
positions to holes 85, 86, 87 when the seat is in reclined condition, ie.
tilted by 10 degrees from the normal to the baby position, when rearward
10 facing.

The central spigot 25 also includes a plurality of slots 92-97 each for
receiving the restraining finger 80 when the seat is turned to a position
corresponding respectively to the positions described in connection with
15 the plunger 88 and holes 82-87, and when the seat is in the reclined
position. This prevents rotation of the seat when the seat is in the reclined
position.

The central spigot 25 also includes a shelf 90 which extends part way
20 round the circumference of the spigot, terminating at wall 91. The shelf
90 effectively forms a rebate in the upper surface 81 of the central spigot
25 which receives a heel portion 60 of the control plate 61 when the seat
10 is rotated to certain predetermined orientations.

25 The plunger 88 resides in a housing 89 and is spring loaded downwards to
engage with any suitably located one of the holes 82-87. It is connected,
by wire pull 99 to a front release lever 100.

Referring back to figure 4, the cushion side bolster cam 64 rotates on its axis 66 which comprises an axle rod 72 held by brackets 68, 69 and 71. At the distal end of the axle rod 72 is an angle drive mechanism 73 which connects with a corresponding axle rod 74 which drives a corresponding arrangement of squab bolster cams (right hand side, 75, shown). The left hand side of the seat corresponds. Thus, rotational movement of the left and right cushion side bolsters 15, 14 forces corresponding movement of the left and right squab side bolsters 17, 16.

The side bolsters are locked into position by one or more spring loaded plungers 76 each of which is engageable with any one of three locking holes 77a, 77b, 77c in the cams 62, 64, 75. Preferably, each of the three locking holes 77 are 15° apart, referenced against the cam axis 63. Each spring loaded plunger 76 is releasable by a wire pull 78, and wire pulls for each plunger 76 (for each cam) may be connected in common to an actuating lever. Alternatively, since all side bolsters are interconnected, only one plunger, wire pull and actuating lever might be required.

In the preferred embodiment shown, right and left side release levers 101, 102 are each connected to a control wire 103 which passes through wire guides 104, 105 and grommet 106. The control wire 103 also connects, by control wires 107, 108 to bell cranks 109, as seen in figure 7, to actuate the various plungers 76 by wire pulls 78.

By virtue of a step 110 in the control plate 61 bearing against the grommet 106, rotation of the control plate 61 in a clockwise direction (as viewed from the perspective of figure 4) also causes actuation of the wire pull 103 independently of both release levers 101, 102, against a bias provided by spring loaded finger 111 which is pivoted on pin 54.

The operation of the seating unit 1 will now be described.

To rotate the seat 10 from the forward facing, normal condition of figures
5 4 and 5, the front release lever 100 is pulled to disengage plunger 88 from
hole 83. The seat is then free to turn through $\pm 45^\circ$ to either engage the
plunger 88 into hole 82 or 84. Anticlockwise movement of the seat (as
viewed from the perspective of figure 6) beyond the 45° position is
precluded by collision of the heel 60 of the control plate 61 with the
10 terminating wall 91 of shelf 90, the collision attempting to rotate the
control plate 61 in an anticlockwise direction, which is blocked by the first
pin 51 in slot 67b.

Clockwise movement of the seat (as viewed from the perspective of figure
15 6) beyond the 45° position causes the heel 60 of the control plate 61 to
gradually be deflected up the tapering wall portion 98 of the shelf 90,
thereby rotating the control plate 61 in a clockwise direction (figure 4).
This results in the step 110 driving grommet 106 rightwards, pulling on
wire pull 99 to release plungers 76 from hole 77a, freeing up bolster cams
20 62, 64, 75 to move the side bolsters 14-17 to their narrow configuration.

After sufficient clockwise rotation of the control plate 61 (viewed in figure
4) it reaches a position where the large diameter section 51a of rod 51 can
pass through the gap 67a which it does under bias, and thus causes the
25 side bolsters 14-17 to move to the narrow (baby) configuration. During
this part of the control plate motion, the grommet 106 is constrained to
move with the control plate 61 by the step 110 and the spring loaded
finger 111. However, further rotation of the control plate 61 allows the
grommet 106 to jump the step 110, against the bias of the spring loaded

finger 111, as it is guided away from the control plate along a guide plate 113. This causes the grommet 106 to return to its original position, thus releasing the wire 103 and subsequently the plungers 76 into holes 77c.

5 Thus, as the seat is rotated to a rearward facing configuration, the side bolsters are automatically moved to the narrow, baby seat configuration.

The seat may be locked in any one of the three rearward facing conditions by engagement of the plunger 88 with one of the holes 85-87. In the
10 rearward facing condition, the side release levers 101, 102 may be actuated to release plungers 76 so that the side bolsters can be moved back to the wide setting. This is permitted because the control plate 61 is tilted such that the pin 51 is passing through the wide part of the slot 67a, which allows either the narrow section 51b or the wide section 51a to pass
15 through the control plate 61. Thus, the seat can be used as both baby seat and child seat in the rear facing conditions.

On returning the seat 10 to a forward facing condition, the front release lever 100 is used to release plunger 88 from the central spigot hole 85, 86
20 or 87 and the seat is rotated toward the forward facing condition. However, movement to the forward facing condition is only permitted when the side bolsters are in a wide (non-baby seat) configuration, to ensure that babies are always carried in a rear facing mode.

25 As the seat 10 is rotated anticlockwise (figure 4a), a pawl 115 pivotally coupled to the second pin 52, engages with a pawl slot 116 in the surface of the central spigot 25 which prevents continued movement round to the forward facing position if the side bolsters are in the narrow (baby) configuration. Once the side bolsters 14-17 have assumed the wide (non-

baby) configuration, and the control plate 61 once again drops into the rebated shelf portion 90 of the central spigot 25, return of the side bolsters 14-17 to the narrow configuration is prevented by the wide section 51a of the control pin 51 being unable to pass through the narrow portion 67b of the slot 67.

If the seat is in the reclined position at any of the six rotational points corresponding to holes 82-87, restraining finger 80 will be engaged in a corresponding one of the slots 92-97 and the seat 10 cannot be rotated until returned to an upright position as shown in the figures.

It will be noted from the configuration of the central spigot 25 that the seating unit 1 is adapted for use as a passenger seat for location on the right hand side of a vehicle, since the preferred direction of rotation from forward facing to rearward facing is clockwise. This means that the rotation will be towards the nearest door of the vehicle. A reverse pattern of central spigot 25, with corresponding changes to the base module 2 mechanism can be used for use on the other side of the vehicle.

In another configuration, the seat 10 is prevented from full 360° rotation by a pin extending down from the seat 10 which collides with a lug situated at an appropriate location on the central spigot upper surface 81, eg. at a minus 90° or minus 120° position with respect to the forward facing side.

With reference now to figures 8 to 11, there is described a preferred head restraint 13 and canopy 7 assembly for the seating unit 1.

The canopy includes a framework 120 which is hinged to a cross-bar 121 between the tops of the tubular support members 40,41. The cross-bar 121 comprises a tubular housing from which extends at one end a pin 122.

The pin 122 engages with a slot 124 in a side plate 123 coupled to the framework 120 to limit movement of the canopy between the upright condition of figure 8 and the deployed condition of figure 9.

The tubular cross-bar 121 also includes a shoot bolt (not visible) which extends from the other end, and engages with one of two holes 125 (only one visible) in a pivot side plate 126 at the side of the canopy framework 120. The shoot bolt engages with one hole to lock the canopy in the upright condition and in the other hole 125 to lock the canopy in the deployed condition. The shoot bolt is spring loaded in the extended position and is withdrawn into the tubular cross-bar 121 to release the canopy by pulling on a wire tab 127 against the spring bias.

The head restraint 13 includes a support frame 130 which preferably includes a pair of seat belt guides 131, 132. The support frame 130 is slidably mounted on a pair of runners 133, 134 between the tubular support members 40, 41. The support frame may thus be positioned in a plurality of positions between a lower position shown in figure 8, corresponding to the baby position, a higher position shown in figure 9 for larger infants, in which it is still possible to deploy the canopy 7, and the highest position shown in figure 10 which is used for the largest child position. In the position of figure 10, it is no longer possible to deploy the canopy, the head restraint lying parallel to and in front of the upright canopy.

The head restraint support frame 130 is preferably lockable in a plurality of height positions by any suitable mechanism, such as a spring biased latching pin which engages in notches or holes (not shown) in the runner 133 or 134.

5

In the preferred embodiment, the rising head restraint support frame includes an integrally mounted seat belt retractor reel 135 which dispenses a belt web 136. The belt web 136 splits at yoke 137 into two shoulder harnesses 138, 139 which pass around the tubular cross-bar and through
10 belt guides 131, 132.

The shoulder harnesses 138, 139 preferably terminate in a suitable buckle arrangement (not shown) which forms a connection with, for example, a lap belt arrangement to form a full four- or even five-point harness.

15

It will be noted that the integrated belt mechanism in the sliding head restraint ensures that, regardless of the height of the occupant of the seat, the shoulder harnesses 138, 139 are correctly positioned for the occupant.

CLAIMS

1. A child seating unit for a vehicle, including:
 - a seat comprising a squab portion and a cushion portion for supporting an occupant of the seating unit;
 - a base module for supporting the seat;
 - means for connecting the seating unit to the vehicle floor;
 - the base module including swivel means to allow the seat to rotate between a forward facing condition and a rearward facing condition while the seat is connected to the vehicle floor.
2. A child seating unit according to claim 1 in which the base module further includes tilt means for rotating the seat about a horizontal axis between a normal seating condition and a reclined condition.
3. A child seating unit according to claim 2 in which the base module includes swivel lock means for preventing rotation of the seat from forward facing condition to rearward facing condition except when the seat is in a normal seating condition.
4. A child seating unit according to claim 2 in which the base module includes swivel lock means for preventing rotation of the seat from rearward facing condition to forward facing condition except when the seat is in a normal seating condition.
5. A child seating unit according to any one of claims 2 to 4 in which the squab portion of the seat includes a pair of squab side bolsters adapted to move between a wide configuration and a narrow configuration.

6. A child seating unit according to any one of claims 2 to 5 in which the cushion portion of the seat includes a pair of cushion side bolsters adapted to move between a wide configuration and a narrow configuration.

5

7. A child seating unit according to claim 8 in which said squab side bolsters and said cushion side bolsters are adapted to move in concert with one another between said wide and narrow configurations.

10 8. A child seating unit according to claim 7 in which said side bolsters are adapted to be lockable into one of a plurality of possible configurations between said wide and narrow configurations.

15 9. A child seating unit according to any one of claims 5 to 8 in which the base module includes an interlock mechanism which prevents the side bolsters from assuming a narrow configuration when the seat is in the forward facing condition.

20 10. A child seating unit according to any one of claims 6 to 10 in which the base module includes an interlock mechanism which causes the side bolsters to assume the narrow configuration when the seat is rotated from a forward facing condition to a rearward facing condition.

25 11. A child seating unit according to claim 2 in which the horizontal axis is a seat reference axis located above the cushion portion and in front of the squab portion.

12. A child seating unit according to claim 11 in which the seat reference axis is positioned to be approximately in line with the hip joints of an occupant of the seat.
- 5 13. A child seating unit according to claim 1 in which said swivel means includes means for locking the seat in a plurality of swivel positions between said forward facing condition and said rearward facing condition.
- 10 14. A child seating unit according to claim 13 in which said swivel means includes means for locking the seat at approximately 0° , $\pm 45^\circ$, $\pm 135^\circ$ and 180° positions where 0° is the forward facing condition.
- 15 15. A child seating unit according to any preceding claim in which the squab portion further includes a canopy adapted to extend forward of, and above the squab portion.
- 20 16. A child seat according to any preceding claim in which the squab portion further includes a head restraint support frame mounted thereon, substantially parallel thereto, and adapted to be slidable between a position above the squab portion to a position in front of, and part way down, the front of the squab portion.
- 25 17. A child seat according to claim 16 in which the head restraint support frame includes at least one seat belt guide integrally formed therewith.
18. A child seat according to claim 17 in which the head restraint support frame includes a pair of seat belt guides, one on each side thereof.

19. A child seat for a vehicle, including:

a squab portion and a cushion portion for supporting an occupant of the seat;

means for connecting the seat to the vehicle;

5 wherein the squab portion further includes a head restraint support frame mounted thereon, substantially parallel thereto, adapted to be slidable between an upper position above the squab portion to a lower position in front of, and part way down, the front of the squab portion.

10 20. A child seat according to claim 19 in which the head restraint support frame includes at least one seat belt guide.

21. A child seat according to claim 20 in which the head restraint support frame includes a pair of seat belt guides, one on each side thereof.

15

22. A child seat according to claim 19 further including a folding canopy adapted to extend forward of, and above the squab portion when the canopy is in a deployed condition.

20 23. A child seat according to claim 22 in which the canopy is adapted to fold to an upright position above the squab portion and substantially coplanar therewith, when not deployed, and wherein the head restraint support frame is adapted, when in its upper position, to lie in front of the canopy.

25

24. A child seat for a vehicle, including:

a squab portion and a cushion portion for supporting an occupant of the seat;

means for connecting the seat to the vehicle;

wherein the squab portion further includes a folding canopy adapted to fold from an upright position above the squab portion and substantially co-planar therewith when not deployed, to a deployed condition in which it extends forward of the squab portion substantially
5 orthogonal thereto.

25. A child seat for a vehicle, including:

a squab portion and a cushion portion for supporting an occupant of the seat;

10 means for connecting the seat to the vehicle;

in which the squab portion and/or the cushion portion of the seat include a pair of side bolsters adapted to move between a wide configuration and a narrow configuration for conversion of the seat between a baby configuration and a child configuration.

15



Application No: GB 9812750.9
Claims searched: 1-18 & 25

Examiner: Jeremy Philpott
Date of search: 24 September 1998

Patents Act 1977
Search Report under Section 17

Databases searched:

UK Patent Office collections, including GB, EP, WO & US patent specifications, in:

UK CI (Ed.P): A4L [LAAR, LAL, LBEJ, LBEP, LBEQ, LCC]

Int CI (Ed.6): B60N: 2/14, 2/26, 2/28, 2/30

Other: WPI, Patents Citation Index

Documents considered to be relevant:

Category	Identity of document and relevant passage	Relevant to claims
X, Y	GB 2297479 A (Deborah Robinson) whole document & Figures	1 (X) 2 & 15 (Y)
X, Y	GB 2207043 A (Charlotte Jane Strong) whole document & Figures	1 (X) 2 & 15 (Y)
Y	WO 96/01748 A1 (Century Products Company) whole document & Figures	2
Y	US 5538319 (Vincent J. DiMurro) whole document & Figures	15
X, Y	US 5183312 (Renolux) whole document & Figures, note col 2 line 65 to col 3 line 3, and col 3 lines 19-26.	1 & 2 (X) 5-8, 15 (Y)
Y	US 5098157 (Ampafrance S.A.) whole document & Figures, note col 1 lines 52-55	5-8
Y	US 5083837 (Beulah Roach) whole document & Figures	15
X, Y	US 4762364 (Rock-A-Bye Restraint Company Inc.) whole document & Figures	1 (X) 2 & 15 (Y)

X Document indicating lack of novelty or inventive step
Y Document indicating lack of inventive step if combined with one or more other documents of same category.

& Member of the same patent family

A Document indicating technological background and/or state of the art.
P Document published on or after the declared priority date but before the filing date of this invention.
E Patent document published on or after, but with priority date earlier than, the filing date of this application.