

**(12) STANDARD PATENT**  
**(19) AUSTRALIAN PATENT OFFICE**

(11) Application No. **AU 2009212972 B2**

(54) Title  
**Force-sensing catheter with bonded center strut**

(51) International Patent Classification(s)  
**A61M 25/01** (2006.01)

(21) Application No: **2009212972** (22) Date of Filing: **2009.09.07**

(30) Priority Data

(31) Number	(32) Date	(33) Country
<b>12/207,155</b>	<b>2008.09.09</b>	<b>US</b>

(43) Publication Date: **2010.03.25**

(43) Publication Journal Date: **2010.03.25**

(44) Accepted Journal Date: **2015.03.05**

(71) Applicant(s)  
**Biosense Webster, Inc.**

(72) Inventor(s)  
**Selkee, Thomas Vaino**

(74) Agent / Attorney  
**Callinans, PO Box 1189, Hartwell, VIC, 3124**

(56) Related Art  
**US 6612992**  
**US 5487757**  
**US 2008/0051704**  
**EP 1690564**  
**US 6272371**  
**US 2002/0165461**

ABSTRACT OF THE DISCLOSURE

5 A force-sensing catheter for diagnosing or treating the vessels found within a body or  
body space includes a center strut that is bonded, preferably thermally, along its  
longitudinal axis with the thermoplastic tubular member within which it is housed.  
The tubular member preferably has three layers: an inner layer, a braided layer and  
an outer layer. . One or more semiconductor or metallic foil strain gages are affixed  
10 to the center strut in order to provide a measure of the bending and torsional forces  
on the distal tip of the catheter. Temperature compensation is achieved by having a  
temperature sensor near the strain gages and calibrating the catheter over a range of  
temperatures.

15

2009212972 07 Sep 2009

**AUSTRALIA**

**Patents Act 1990**

**ORIGINAL**

**COMPLETE SPECIFICATION**

---

**INVENTION TITLE:**

**FORCE-SENSING CATHETER WITH BONDED CENTER STRUT**

---

The following statement is a full description of this invention, including the best method of performing it known to us:-

## FORCE-SENSING CATHETER WITH BONDED CENTER STRUT

## FIELD OF THE INVENTION

5 [0001] The present invention relates to a medical device for use in the vessel of a patient for the purpose of diagnosing or treating the patient, such as mapping tissue and/or ablating tissue using radio frequency (RF) or other sources of energy. More particularly, the invention relates to a catheter having a center strut bonded into the catheter tip to define an inseparable composite tip structure that maximizes the open  
10 internal volume of the catheter tip and the torsional rigidity of the catheter tip while minimizing the outside diameter of the catheter tip and providing uniform on-plane tip deflection. On the bonded center strut one or more strain gage force sensors are affixed for measuring catheter tip deflection and tip axial and side forces. The catheter may also include puller wires for deflecting the tip portion of the catheter.

15

## BACKGROUND OF THE INVENTION

[0002] Many abnormal medical conditions in humans and other mammals have been associated with disease and other aberrations along the lining or walls that define  
20 several different body spaces. In order to treat such abnormal conditions of the body spaces, medical device technologies adapted for delivering various therapies to the body spaces using the least invasive means possible.

[0003] As used herein, the term "body space," including derivatives thereof, is  
25 intended to mean any cavity within the body which is defined at least in part by a tissue wall. For example, the cardiac chambers, the uterus, the regions of the gastrointestinal tract, and the arterial or venous vessels are all considered illustrative examples of body spaces within the intended meaning.

30 [0004] The term "vessel," including derivatives thereof, is herein intended to mean any body space which is circumscribed along a length by a tubular tissue wall and which terminates at each of two ends in at least one opening that communicates externally of the body space. For example, the large and small intestines, the vas deferens, the trachea, and the fallopian tubes are all illustrative examples of vessels

within the intended meaning. Blood vessels are also herein considered vessels, including regions of the vascular tree between their branch points. More particularly, the pulmonary veins are vessels within the intended meaning, including the region of the pulmonary veins between the branched portions of their ostia along a left ventricle wall, although the wall tissue defining the ostia typically presents uniquely tapered luminal shapes.

[0005] One means of treating body spaces in a minimally invasive manner is through the use of catheters to reach internal organs and vessels within a body space. Electrode or electrophysiology (EP) catheters have been in common use in medical practice for many years. They are used to stimulate and map electrical activity in the heart and to ablate sites of aberrant electrical activity. In use, the electrode catheter is inserted into a major vein or artery, e.g., the femoral artery, and then guided into the chamber of the heart that is of concern in order to perform an ablation procedure.

[0006] United States Patent No. 6,272,672 to Ben-Heim discloses the use of one or more piezoelectric elements or strain gages for generating signals indicative of bending about the axes of a catheter. While this patent discusses the use of such sensors for measuring and depicting the bend of the catheter to the user it does not provide a means for accurately providing force sensing at the tip of the catheter.

[0007] United States Patent No. 6,612,992 to Rambow et al. discloses an ultrasound catheter that uses a plurality of strain gages placed along the periphery of the catheter to provide information regarding the position of the catheter in the cardiovascular system, however, there is no teaching with respect to sensing the force at the tip of the catheter.

[0008] As EP catheters are used in more procedures where tissue perforation is an issue, it would be desirable to have a tip electrode that provides more feedback such as force detection and tissue contact while having similar characteristics to existing EP catheter tips electrodes.

[0009] Furthermore, as EP catheters are used to ablate dynamically moving tissue, it will be necessary to have a catheter that accurately measures the force at the tip of the catheter while also having desirable deflection characteristics such as on-plane deflection.

5 SUMMARY OF THE INVENTION

[0010] The invention is directed to a force-sensing catheter having a longitudinal axis for use in a vessel including: an elongate tubular member having a proximal end and a distal end, the distal end including a deflectable tip portion termination in a distal tip, the elongate tubular member having a central lumen disposed through the proximal end and two half-cylindrical lumens in the deflectable tip portion; a tip electrode disposed at the distal tip of the deflectable tip portion; a center strut having a rectangular beam section along the longitudinal axis extending from near the proximal end of the tip electrode through the deflectable tip portion of the elongate tubular member and having a first longitudinal edge and a second longitudinal edge and a first side and a second side wherein the width of the first side and the second side are greater than the width of the first longitudinal edge and the second longitudinal edge respectively; wherein the center strut is bonded to the elongate tubular member substantially along entire length of the first longitudinal edge and the second longitudinal edge to form the two half-cylindrical lumens and create an inseparable composite structure from the center strut and the elongate tubular member; and, at least one strain gage, the at least one strain gage affixed to only the first side or the second side of the center strut, the at least one strain gage oriented and configured to detect a bending strain or a torsional strain in the center strut for measuring force near the distal end of the tubular member.

25 [0011] The strain gages are affixed to the bonded central strut in distinct orientations. Bending strain is detected by the strain sensor affixed in parallel to the longitudinal axis of the strut. Torsional strain is detected by the two strain sensors oriented at 90 degrees to each other and at forty-five degrees with respect to the longitudinal axis of the strut. Because both bending and torsional strains of the bonded center strut are monitored and the strut is bonded along its longitudinal edge to the inner diameter of the elongate tubular member, forces applied to the outer diameter of the catheter tip can be determined. For added sensitivity, at the location of the torsional deflection sensors the center strut may be “necked down” or slotted to provide a means of amplifying the sensed strain. The strain gage may be either a silicon based strain gage or a metallic foil strain gage. Circuitry for determining strain based on the resistance seen at the strain gage resides in the handle of the catheter and/or the navigation or ablation system to which the catheter is connected. Most metallic strain

gage alloys exhibit a nearly linear gage factor variation over a broad temperature range which is less than  $\pm 1\%$  within  $\pm 100^\circ\text{C}$ . In two-wire installations, the error introduced by lead-wire resistance is a function of the resistance ratio  $R1/Rg$ . The lead-wire error is usually not significant if the lead-wire resistance ( $R1$ ) is small in comparison to the gage resistance ( $Rg$ ), but if the lead-wire resistance exceeds 0.1% lead-wire temperature compensation should be provided for improved measurement accuracy. Temperature compensation is required for silicon based strain gages. Temperature compensation can be based on the temperature sensors which are used as a means of feedback control in ablation catheters.

5  
10 [0012] The catheter further comprises first and second puller wires having proximal and distal ends. Each puller wire extends from a control handle at the proximal end of the catheter body through a lumen in the catheter body and into one of the lumens in the tip section. The puller wires may be disposed in a tubular sleeve dimensioned so as to maintain the puller wires in close adjacent relationship. The distal ends of the  
15 puller wires are fixedly attached either to opposite sides of the center strut, to the tip electrode or the tubular structure of the distal tip section of the catheter.

[0013] The control handle includes a steering assembly having a lever arm carrying a pair of pulleys for drawing corresponding puller wires to deflect the tip section of the  
20 catheter. The pulleys are rotatably mounted on opposing portions of the lever arm such that one pulley is moved distally as the other pulley is moved proximally when the lever arm is rotated. Because each puller wire is trained on a respective pulley, rotation of the lever arm causes the pulley that is moved proximally to draw its puller wire to deflect the tip section in the direction of the off-axis lumen in which that  
25 puller wire extends.

[0014] Specifically, the present invention is a composite catheter tip comprising an extruded thin walled elastomeric tube spirally wrapped with a reinforcing braid wherein the elastomeric tube that has a center strut comprised of a thin elongated  
30 rectangular metallic strip where both thin longitudinal sides (edges) of the said strip are bonded, preferably thermally, to the inside wall of the elastomeric tube thereby creating a composite structure with inseparable members. The term "inseparable" is

used to denote the creation of a composite structure between the elastomeric tube and the metallic strip so that any attempt to separate the elastomeric tube and metallic strip would cause irreversible destruction of the composite structure.

5 [0015] This composite tip structure provides two enclosed, large diametrically-opposed, half moon shaped lumens extending through the tip providing space for wiring, sensors, fluid carrying tubing and the like. The strut separating the half moon shaped lumens can be constructed from any of a number of superelastic (metallic) alloys such as nitinol, beta titanium or spring tempered stainless steel. This  
10 composite catheter tip design maximizes the cross-sectional area of the open lumens in the catheter tip and torsional rigidity of the catheter tip while minimizing the outer diameter of the catheter tip by providing a single uniform area moment of inertia at any cross section of the catheter tip the longitudinal axis because the bonded center strut and elastomeric tube are not allowed to move with respect to each other during  
15 tip deflection. This composite structure provides uniform on-plane tip deflection and uniform torque and deflection forces regardless of the tip deflection angle because the tip cross-sectional area moment of inertia remains constant along the entire tip length during tip deflection. All known prior art tip designs exhibit varying cross-sectional area moments of inertia during tip deflection because the inner strut and  
20 outer elastomeric tube are fixed to each other only at their proximal and distal end locations and the strut and outer tube move with respect to each (other) during tip deflection. In all prior art designs, the combined centroidal axis of the independently moving strut and outer tube is continuously variable during tip curvature since the absolute distance between the centroidal axis of the whole (strut and outer tube) and  
25 the centroidal axis of each of the parts is variable. This produces non-uniform torque and deflection forces that are dependent on the degree of tip curvature.

[0016] The deflection curve profile of the catheter tip can be modified by varying the area moment of inertia of the strut cross section perpendicular to the struts  
30 longitudinal axis by utilizing cutting or coining operations that either remove material or change the material thickness in various portions of the center strut cross section. The composite deflecting tip with a bonded center strut has a large width to



thickness ratio thus providing a first centroidal axis that has a large area moment of inertia and a second corresponding low area moment of inertia about a centroidal axis orthogonal to the first centroidal axis thereby providing exceptional on-plane deflection characteristics.

5

[0017] The present invention provides a single unified high-performance composite structure for the deflecting tip assembly of a deflectable catheter that combines the properties of elastomers and metals and eliminates extruded core lumens. The two half-cylindrical lumens created by the bonded strut provide a large volume in which to place wiring, tip force and location sensors and tip irrigation lumens.

10

Alternatively, an intermediate portion between the deflectable tip section and the tip electrode can be provided in which there is no center strut and which provides even greater room for temperature and location sensors. Catheter tip diameters can be reduced since the working volume of the tip lumen is maximized with this design.

15

[0018] In a preferred embodiment of the catheter an elongate tubular member having a proximal end and a distal end and having a lumen is thermally bonded to the longitudinal edges of a center strut that extends in the deflectable portion of the catheter. This bonding creates an inseparable composite structure from the elongate tubular member and the center strut.

20

[0019] A tip electrode is disposed at the distal end of the tubular member. A molded coupling has a distal portion adapted to receive a portion of the proximal end of the tip electrode and a proximal portion having at least one slot adapted to receive at least one of the first or second longitudinal edges of the center strut.

25

[0020] The distal end of the center strut comprises at least one snap-fit notch and the molded coupling further comprises at least one snap-fit wedge adapted to receive the snap-fit notch. This construction enables the rapid assembly of the tip electrode and the composite tubular member and center strut.

30

35

## BRIEF DESCRIPTION OF THE DRAWINGS

5 [0021] FIGS. 1A-C are a planar views of a deflectable EP catheter with rocker type deflection control handle in accordance with the present invention.

[0022] FIG. 1D is a planar view of the friction control knob located on the rocker type deflection control handle.

10 [0023] FIG. 2 is a longitudinal cross-sectional view of the deflectable distal tip section and a portion of the proximal section of the catheter of FIG. 1 including strain gage force sensors on the bonded center strut.

15 [0024] FIG. 3 is a cross-sectional view of the tubular section of the EP catheter of FIG. 2 through line A-A.

[0025] FIG. 4 is an exploded perspective view of the distal tip of an embodiment of a deflectable catheter in accordance with the present invention.

20 [0026] FIG. 5 is a perspective view of a tip electrode of the deflectable tip section of a catheter in accordance with the present invention.

[0027] FIG. 6 is a cross-sectional perspective view of a molded coupling of the deflectable tip section of a catheter in accordance with the present invention.

25

[0028] FIG. 7a is a planar view of a puller wire for use in the deflectable tip section of a catheter in accordance with the present invention.

30 [0029] FIG. 7b is a perspective view of the distal section of a deflectable catheter in accordance with the present invention.

[0030] FIG. 8 is an elevational view of a center strut in accordance with a further embodiment the deflectable tip section of a catheter in accordance with the present invention.

5 [0031] FIG. 9 is a perspective view of the device for manufacturing the deflectable tip section of a catheter in accordance with the present invention.

[0032] FIG. 10 is a perspective view of the distal tip of a deflectable catheter in accordance with the present invention.

10

[0033] FIG. 11 is a perspective view of the distal tip of a deflectable catheter in accordance with the present invention.

[0034] FIG. 12 is a planar view of a portion of the bonded center strut having the strain gage force sensors mounted thereon.

15

[0035] FIGS. 13 is a planar view of a strain gage force sensor for use in the catheter of the present invention.

20 [0036] FIG. 14 depicts a schematic for the force measurement circuitry for use in a deflectable catheter having a silicon MEMS strain gage sensor in accordance with the present invention.

[0037] FIG. 15 depicts a schematic for the force measurement circuitry for use in a deflectable catheter having a metallic foil strain gage sensor in accordance with the present invention.

25

## DETAILED DESCRIPTION OF THE INVENTION

[0038] FIGS. 1A-C depict a planar view of an embodiment of a deflectable catheter in accordance with the present invention. As shown in FIG. 1B, a preferred catheter 100 comprises an elongated tubular catheter body having a proximal section 32, a distal tip section 34 and a control handle 36 at the proximal end of the proximal section 32. Tip electrode 38 and optional ring electrode 40 are placed at or near deflectable distal tip section 34 so as to provide a source of ablation energy if the desired device is an RF ablation catheter or for receiving electrical signals if the catheter is a diagnostic EP mapping catheter. Control handle 36 may be one of many designs capable of placing a pulling force on puller wires used to deflect the deflectable tip section 34. Preferably, control handle 36 is the handle used in the Biosense EZ-Steer bidirectional family of products which control handle is depicted in FIGS. 1A-C. The "rocker" type lever 37 pulls one of two puller wires to deflect the catheter tip in one direction (FIG. 1A) then can alternatively select the second (opposite) puller wire to deflect the catheter tip in the other direction (FIG. 1C). The control handle 36 also had an adjustable friction control knob 37a shown in FIG. 1D that allows the operator to use the rocker lever 37 in a free state or to adjust the tension to lock the rocker level 37 and the deflected tip in place. The amount of friction in the movement of the rocker lever 37 increases as the friction control knob 37a is rotated clockwise until it reaches the fully locked position.

[0039] FIG. 2 depicts a cross-sectional view of the transition from proximal section 32 and deflectable section 34 of catheter 100 taken perpendicular to the center strut 80 that forms a portion of the catheter and FIG. 3 depicts the cross-section of the catheter of FIG. 2 through line A-A. Catheter 100 comprises an elongated tubular construction having a central lumen 58 through the distal portion 32 and two half-cylindrical lumens 58a and 58b in the deflectable tip portion 34. The proximal section 32 is flexible but substantially non-compressible along its length. Proximal section 32 can be made of any suitable construction and made of any suitable material. The preferred construction comprises an outer wall 30 made of Pellethane or PEBAX and an optional inner wall 18. The outer wall 30 may also comprise an

imbedded braided mesh of stainless steel or similar material to increase torsional stiffness so that when control handle **36** is rotated the distal end of proximal section **32** as well as the distal section **34** will rotate in a corresponding manner.

5 [0040] The overall length of the length of the catheter will vary according to its application for use but a preferred length is between approximately 90 and 120 cm and more preferably between approximately 100 and 110 cm. The outer diameter of the proximal section **32** is also a design characteristic that varies according to the application of the catheter but is preferably less than approximately 8 French (Fr).  
10 Optional inner wall **18** comprises a polymeric tube which may optionally be spirally-sliced and is sized so that the outer diameter is about the same size or slightly smaller than the inner diameter of outer wall **30** thereby providing additional stiffness which can be controlled by the pitch angle of the spiral slice.

15 [0041] In the embodiment shown, the distal section **34** and the proximal section **32** are separate structures that have been fixedly attached to each other. Proximal section **32** and distal section **34** may be attached using a polyurethane adhesive at the joint **35** between the two sections. Other means of attachment include joining the proximal and distal sections using heat to fuse the sections together.

20 [0042] In the EP catheter of the present invention, tip electrode **38** and optional ring electrodes **40** shown in FIGS. 1A-1C are each electrically connected to one of the bundle of lead wires **70**. Each wire in the bundle of lead wire **70** extends from the control handle **36** through the lumen **58** in the proximal section **32** and through one  
25 of lumens **58a** or **58b** in distal section **34** to tip electrode **38** and optional ring electrode (or electrodes) **40**. The proximal end of each lead wire **70** is connected to an appropriate connector (not shown) in the control handle **36** which can be connected to a suitable source of RF energy or to an EP mapping or other diagnostic or therapeutic system.

30 [0043] Irrigation lumen **90** provides a conduit for transporting fluid from the proximal end of the catheter to the distal tip portion **34**. Irrigation lumen **90** is in

fluid communication with one or more fluid ports in the tip electrode **38**. FIGS. 4 and 5 depict on possible arrangement of irrigation fluid ports **439** in a tip electrode. Irrigation lumen **90** is used to transport an irrigation fluid through the catheter and out through the fluid ports in the tip in order to reduce coagulation of bodily fluids such as blood at or near the tip electrode.

[0044] In a bi-directional catheter a pair of puller wires **44a** and **44b** extend through the through lumen **58** in the proximal section **32** and each extend through one of lumens **58a** and **58b** in distal section **34**. The puller wires are made of any suitable material such as stainless steel or Nitinol wire or a non-metallic yarn such as Vectran® material. Preferably, each puller wire **44** is covered with a lubricious coating such as PTFE or a similar material. Each puller wire **44** extends from the control handle **36** to near the tip of distal section **34**.

[0045] A sleeve or sleeves (not shown) may be used to house the puller wires proximally to the soft tip of the catheter. The sleeve is used to keep each puller wire on its respective sides of the center strut. For bi-directional deflection the opposing puller wires will always be placed in a separate lumen. With this design placing multiple puller wires in one lumen would be used for achieving different deflection curves in one deflection direction. Such a sleeve may be made of any suitable material, e.g., polyamide or polyurethane.

[0046] Examples of other suitable control handles **36** that can be used with the present invention are described in United States Patent No. 6,123,699, 6,171,277, 6,183,463 and 6,198,974 the disclosures of which are hereby incorporated by reference. In such control handles proximal movement of the thumb control relative to the handle housing results in proximal movement of the first piston and first puller wire relative to the handle housing and catheter body, which results in deflection of the tip section in the direction of the lumen into which the first puller wire extends. Distal movement of the thumb control relative to the handle housing results in distal movement of the first piston, causing proximal movement of the second piston and puller wire relative to the handle housing and catheter body, which results in

deflection of the tip section in the direction of the lumen into which the second puller wire extends. Additional configurations of puller wires **44** and gearing within the control handle may be used such as those disclosed in United States Patent No. 7,077,823 which is also hereby incorporated by reference.

5

[0047] The distal section **34** is comprised of an inner layer **62**, braid layer **64** and outer layer **66** of the distal tip section. The inner layer **62** of the distal section **34** of a catheter is a thin layer of a thermoplastic elastomeric material, preferably between 0.0025-0.0035 inch in thickness. The inner layer **62** is a synthetic fiber braid layer **64** of approximately 0.002 to 0.003 inches in diameter. In a preferred embodiment the synthetic fiber is Pen monofilament from Biogeneral Advanced Fiber Technology. Outer layer **66** is an elastomeric material extruded over the braided inner layer. The inner layer **62** and the outer layer **66** may be made from elastomers having the same shore hardness or from materials having different shore hardnesses. Preferably, the elastomer is PEBAX or Pellethane due to processability and high heat deflection temperatures.

10  
15

[0048] Additionally, a safety wire **95** may be used to secure the tip electrode to the catheter shaft so as to prevent detachment of the tip electrode. The safety wire is preferably a 0.0065 inch monel which is routed through the lumen **58** in the proximal portion **32** of the catheter as well as through one of the two lumens **58a** or **58b** in the distal tip portion **34**. The distal end of the safety wire is attached to the tip electrode **38** while the proximal portion is attached to an anchor point inside the control handle **36**.

20  
25

[0049] FIG. 4 depicts an exploded view of the distal tip of a deflectable catheter in accordance with the present invention. FIG. 5 is a perspective view of tip electrode **438**. Tip electrode **438** depicted in FIGS. 4 and 5 is a machined metallic electrode comprised of a metal that is non-reactive in bodily fluid such as of gold, platinum, palladium or an alloy thereof. Tip electrode **438** may also be made of a first metal such as copper, silver, gold, aluminum, beryllium, bronze, palladium or alloys

30

thereof which is then plated either internally and/or externally with a non-reactive metal such as gold, platinum, palladium or an alloy thereof. Tip electrode **438** may include a plurality of irrigation ports **439** connected to a central irrigation lumen **440** although such ports and lumens are optional. The proximal end of tip electrode **438** comprises a base **437** having a smaller diameter than the remainder of the tip electrode and adapted to fit coupling **442**. Base **437** may include a plurality of serrations **437a** that improve the bonding of tip electrode **438** into coupling **442**. Base **437** of the tip electrode **438** is heat bonded or ultrasonically welded to the coupling **442**. Tip dome **438a** may be machined to provide a rounded atraumatic distal tip in order to reduce tissue damage during placement and/or use of the catheter. Lumen **495** provides a passageway for safety wire **95** and lumen **470** provides a passageway for lead wire **70** that provide energy to the tip electrode **438**. Lead wire **70** is attached to tip electrode **438** using a conductive solder or epoxy.

[0050] Injection molded coupling **442** depicted in FIGS. 4 and 6 has a distal section **443** with an internal diameter at its distal end adapted to receive the base **437** of tip electrode **438** and has a proximal section **441** with a slot **441a** adapted to receive the distal end **480** of the center strut **80**. Coupling **442** is injection molded from a medical grade polymer such as PEEK, ABS or Polycarbonate or other appropriate material known to one skilled in the art. Distal end **480** of center strut **80** also includes a snap-fit notch **481** adapted to lock over snap-fit wedge **441b** in the coupling **442** thereby providing an mechanism for the quick assembly of the distal section of the deflectable catheter which method is described in greater detail below. Puller wire anchor holes **444a** and **444b** are lumens that are adapted to receive puller wires **44a** and **44b**. Puller wires adapted for this use are shown in FIG. 7A. Puller wires **44a** and **44b** for use in this embodiment are preferably made of Vectran<sup>®</sup> wire which has had a ball of epoxy **444c** attached to its distal end. The Vectran<sup>®</sup> wire should be cleaned with alcohol and/or an ultrasonic bath before application of a ball of epoxy that is then cured under ultraviolet light. It is important that the epoxy be well fixed to the distal end of the puller wires **44a** and **44b**. Alternatively, the puller wire could be high strength stainless steel (304V) to which a ball is produced at one end using a high-speed laser melting process.



[0051] Near the distal end **480** of center strut **80** are mounted one or more strain gages **490a-c**. The strain gages are affixed to the bonded central strut in distinct orientations. Bending strain is detected by the strain gage **490c** affixed in parallel to the longitudinal axis of the strut. Torsional strain is detected by the two strain sensors **490a** and **490b** oriented at 90 degrees to each other and at forty-five degrees with respect to the longitudinal axis of the strut. Because both bending and torsional strains of the bonded center strut are monitored and the strut is bonded along its longitudinal edge to the inner diameter of the elongate tubular member, forces applied to the outer diameter of the catheter tip can be determined. For added sensitivity, at the location of the torsional strain gages **490a** and **490b** the center strut may be "necked down" by removing portions **492** from the edge of the center strut **80** as depicted in FIG. 12. Likewise, sensitivity for the bending strain may be amplified by cutting one or more slots **494** into center strut **80**. Alternatively, a double set of strain gages located on opposite sides of the center strut may be used with one in compression and the other in tension. In this arrangement, the bridge output for the same strain can be effectively doubled. In installations where all of the bridge arms are connected to strain gages, temperature compensation is automatic, as resistance changes due to temperature variations will be the same for all arms of the bridge.

[0052] FIG. 13 depicts a typical strain sensor for use in the present invention. The preferred strain gage **490** is a rectangular single-crystal or polycrystalline silicon member aligned to the direction of the measured strain. The lead wire attachment pads **496** on either side of the sensing member **498** are designed with a symmetrical, low-stress geometry to minimize the residual stress effects on the silicon bar. They can be either conventional solder pads or wire bond pads. An aluminum surface is typically used for wire bonding and a gold-plated nickel surface for soldering. Because they are the largest feature of the strain gage device the pads determine the size of the device and the total device can be sized down to fractions of a square millimeter. A rugged, low-stress polyimide backing similar to Kapton tape supports the entire structure whose total thickness is typically less than 1 mil. Because the

element and the pad structure are foil thin the entire strain gage has a bend radius of less than 0.06 inch.

5 [0053] Lead wires preferably comprise a miniature shielded cable comprised of three inner twisted pair No. 38-48 (copper) average wire gage (AWG) double insulated poly nylon covered conductors covered with a shield and then a FEP jacket overlay. Since there are a minimum of three strain gages requiring a minimum two wires each (three wires for foil gage temperature compensation ), there six total wires would be required in this embodiment. If temperature compensation at the strain gage location 10 is utilized, at least two more wires would be required for temperature sensing using a thermocouple or thermister.

[0054] The center strut **80** is comprised of a rectangular beam section thus simple beam bending along its longitudinal axis is easy to define, but complicated 15 deformation is induced with the addition of torsional deflection of the center strut which is a superposition of the combined stresses and variations in the tip force vectors make this a complex problem. Strain is defined as the amount of deformation per unit length of an object when a load is applied. Bending strain (moment strain) is calculated by determining the relationship between the tip curve 20 deflection and the amount of bending which results from it. Torsional strain is measured when twisting of the catheter tip during side deflection produces a twisting strain component. Torsional strain is calculated by dividing the torsional stress by the modulus of elasticity.

25 [0055] The three main factors influencing the election of the strain sensor are operating temperature, strain state (gradient, magnitude, and time dependence) and required system stability. An ideal strain sensor would change resistance only due to the deformations of the center strut member, but temperature, material properties, the adhesive used to bond the sensor to the surface of the center strut and the stability of 30 the strut member all affect the measured resistance. The two types of strain gages (semiconductor and metal based foil) could be used for sensing the center strut deflection characteristics but semiconductor sensors are the preferred type.

Semiconductor sensors are more elastic than metallic foil sensors and therefore have a high propensity to return to their unstrained shape. Semiconductor sensors have a gage factor of fifty times and a sensitivity of more than 100 times (30-120) compared to metallic foil sensors which have significantly lower gage factors and sensitivity.

5 Semiconductor sensors come in a much smaller package size at a much lower cost than for metallic foil sensors. For semiconductor sensors the resistance-to-strain relationship is nonlinear varying by 10-20% from a straight-line equation, but this is known in advance and can be compensated for mathematically. Lead wires for semiconductor based strain gages are very small and are connected to the gage by  
10 conductive epoxy, wire bonding, laser soldering/welding or ultrasonic means.

[0056] Because the center strut member is bonded along its longitudinal edge to a braided catheter tip, the sensor calibration must be performed on each semi-finished or finished catheter at the catheters operational temperature (i.e., body temperature).

15 Manufacturing variables such as variations in the catheter shaft material properties (elastic and torsional modulus), braid pitch variation, braid diameter and tip material dimensional tolerances necessitate this requirement. Strain sensor calibration data for each catheter can be stored in an EEPROM or other storage means in the handle of the catheter so as to provide easy access to the necessary operational information.  
20 Dynamically monitoring and recording strain sensor outputs, catheter puller wire tension force and tip location as the catheter tip is deflected at different angles while exposed to different tip loading force vectors is required. Utilizing flexible catheter tip materials such as PEBA<sup>X</sup> or Arnitel<sup>®</sup> (thermoplastic copolyester based elastomer) that have a stable and flat modulus at catheter operation temperatures will  
25 increase contact force measurement accuracy.

[0057] A single puller wire **44**, made of a non-metallic yarn such as Vectran<sup>®</sup> material, may be attached to the distal end of the catheter by threading the puller wire through one or more anchor holes **82a-e** in center strut **80** so that the opposing ends  
30 of the puller wire, **44a** and **44b**, reside on opposing sides of the center strut as depicted in FIG. 8. Such anchor holes **82a-e** in center strut **80** preferably have a diameter of 0.015 inch and are spaced apart by approximately 0.078 inch. Such

anchor holes may be placed in the center strut **80** by laser cutting, punching and drilling. The number of holes on the strut, and the placement of the puller wires in one or more anchor holes **82a-e** will alter the curve shape and allow for both symmetric and asymmetric curve designs. For creating a symmetric curve the  
5 opposing ends of the puller wires would exit the same anchor hole towards opposing sides of the strut. Means for changing curve shape can be controlled by the distance between anchor holes used for the opposing ends of the puller wire. When the end of each of the pull wires **44a** and **44b** are attached to opposing sides of the center strut **80**, pulling pull wire **44a** or **44b** in the proximal direction will cause the distal end of  
10 the catheter **100** to deflect in-plane in the direction of the off-axis lumen in which the respective puller wire extends.

[0058] An alternate embodiment (not shown) uses two puller wires with metallic ferrules or plastic slugs to constrain the puller wires in their respective anchor hole  
15 located in the center strut. The puller wire would be threaded through the center strut on one side using the ferrule as a constraint from pulling completely through the anchor hole. An additional method for anchoring the puller wires is soldering, welding or using an adhesive to attach them to the center strut.

[0059] Alternatively, the puller wires do not need to be attached to the center strut. A puller wire or puller wires could be attached to the tip dome or the distal end of the catheter's soft deflectable tip section. FIGS. 9-11 show multiple configurations of  
20 tip electrodes **38** that are adapted to receive a single puller wire **44**. The single puller wire **44** connected to the tip electrode **38** provides bi-directional control. To achieve this, a single puller wire is threaded through the dome electrode with the opposite  
25 sides of the puller wire residing on opposite sides of the center strut. Deflection direction will correspond with the path of least resistance. Moreover, individually manipulating a puller wire will result in in-plane deflection in the direction of the off-axis lumen in which the respective puller wire extends. Such embodiment  
30 directly supports symmetric curve designs.

[0060] FIGS. 10 and 11 depict hollow tip electrodes **38** that are adapted to receive a plug **45** which is force fit into the hollow dome. Puller wire **44** is threaded through the plug. One or more puller wires may be anchored in this manner. The puller wire is constrained in place once the plug is appropriately placed in the tip electrode.

5

[0061] FIG. 7B depicts another embodiment of the distal tip section of the catheter **100** where the puller wires are attached to the side wall of the distal tip section **34** of catheter **100**. A small hole **71** is drilled through the inner layer **62**, braid layer **64** and outer layer **66** of the distal tip section. After the hole **71** is drilled, a grinder is used to lightly reduce the outer profile around the hole by removing approximately length=.04" depth=.013" of material. A stainless steel puller wire bar **72** is attached to the distal end of the puller wire **44** via crimping to a ferrule or other means of adhesion. When the puller wire **44** is brought through the anchor window the bar rests on the outer profile of the thermoplastic soft deflectable tip section. Polyurethane is used to pot over the puller wire bar **72** thereby rebuilding the original profile of the distal tip section **34**. In this manner each puller wire may be anchored to the outer periphery of the catheter **100** at any location along the longitudinal axis of the distal tip section **34**. It is possible to anchor multiple puller wires in this manner, each on opposing sides of the center strut. Changing the location of the anchoring location changes the deflection profile of the catheter.

10  
15  
20

[0062] The proximal end of the center strut **80** extends out of the proximal end of the soft deflectable tip portion. The proximal end of the center strut may be tapered so it can be readily placed within the proximal section **32** of the catheter helping to support the transition area. A sleeve preferably composed of PTFE may be placed over the tapered portion of the center strut constraining the puller wires and thereby preventing them from crossing. The sleeve is form fitting so it is tight around the center strut and wires but not so tight as to prevent the puller wires from readily moving in the longitudinal direction.

25  
30

[0063] FIG. 14 depicts the schematic for a measurement circuit **500** for use with a force-sensing catheter having the silicon based strain gages. Measurement circuit **500** utilizes a high-resolution, sigma-delta analog-to-digital converter (ADC) **502**

that includes differential inputs, programmable internal amplifiers, automatic zero calibration, high common-mode rejection, and digital noise filtering to aid in the strain sensor integration to accurately measure bridge circuit voltage output. Silicon strain gages 490 exhibit a high temperature coefficient of resistance (TCR) (temperature sensitivity) compared to constantan and other metal foils therefore temperature compensation circuitry and software algorithms (tables of temperature coefficients) are required as discussed below.

$$V_{OUT} = V_B \times (S \times S_0 \times (1 + S_1 \times (T - T_r)) + U_0 + U_1 \times (T - T_r)) \quad (1)$$

Equation (1) sets forth the formula for calculating the detected strain, where  $V_{OUT}$  is the bridge voltage output,  $V_B$  is the bridge excitation voltage,  $S$  is the applied sensor strain,  $T_r$  is the reference temperature measured near the silicon strain sensor,  $S_0$  is the strain gage sensitivity at reference temperature  $T_r$ ,  $S_1$  is the temperature coefficient of sensitivity (TCS),  $U_0$  is the offset or unbalance of the bridge at  $T_r$  with no strain applied, and  $U_1$  is the offset temperature coefficient (OTC). OTC is the error band defined by the maximum deviation in offset voltage as the temperature is varied from 25°C to any other temperature within the specified range. TCS corresponds to the slope of a tangent on the curve sensitivity versus temperature. Specifying this coefficient makes sense only if a linear or nearly linear relationship between temperature and sensitivity exists (Units: ppm/°C). The semiconductor strain gages that would be utilized in this application have a linearity of ±0.25% to 600u inch/inch and better than ± 1.5% to 1500u inch/inch.

[0064] Equation (1) uses first-order polynomials to model the silicon strain gage. To obtain higher measurement accuracy, higher-order polynomials, discrete interval linear techniques, or discrete interval second-order approximations with a table of coefficients may also be used. Digital calibration requires the ability to digitize  $V_{OUT}$ ,  $V_B$ , and  $T$ , as well as a way to determine all the coefficients and perform the necessary calculations by utilizing a microcontroller or computer to calculate an accurate strain value.

[0065] The circuit shown in the FIG. 14 uses a single high-resolution ADC **502** to digitize  $V_{OUT}$ , the temperature near the silicon strain gage, and  $V_B$  (bridge voltage). These measurements are then sent to a microprocessor or computer **504** (housed either in the handle of the catheter or in the ablation or navigation system to which the catheter is connected) where the strain is calculated using Equation (1).  
5 Microprocessor or computer **504** may be any type of general purpose computing device capable of providing mathematical computations by executing object code residing in an associated memory device. The bridge circuit is powered directly from the same power supply (not shown) as the ADC and the reference voltage  $V_r$  **506**. A  
10 resistance temperature detector (RTD) or thermocouple comprising temperature sensor **508** measures the temperature near the silicon strain sensor for temperature compensation purposes. The strain sensor may also contain an integrated temperature sensor for temperature compensation purposes. The input multiplexer on the ADC **502** allows multiple silicon strain gage bridge voltages to be measured using the  
15 same ADC. To determine the temperature calibration coefficients, the catheter with internal silicon strain sensors is placed in a temperature controlled chamber or water bath and bridge voltage measurements are made at several different temperatures where the catheter will be used to determine the temperature calibration coefficients. These temperature calibration coefficients are then stored in a memory device  
20 associated with the catheter such as an EEPROM in the handle **36** of the device for use by the microprocessor **504**.

[0066] Because of its outstanding sensitivity, the Wheatstone bridge circuit **510** is used for static strain measurement. Ideally, the strain gage is the only resistor in the  
25 circuit that varies and the bridge is considered balanced when  $R1/R2 = Rg/R3$  and, therefore,  $V_{OUT}$  equals zero. When the bridge is set up so that  $R_g$  is the only active strain gage, a small change in  $R_g$  will throw the bridge out of balance resulting in an output voltage from the bridge.

30 [0067] For effective temperature compensation in metal foil strain gages **90** with long lead wires as in a catheter tip force-sensing application, a three-wire connection to the strain gage can be utilized as shown in FIG. 15. One-half of the lead wire resistance ( $1/2RL$ ) is applied to the adjacent side of the Wheatstone bridge **510** to

compensate the resistive components of the two leads affected by a similar temperature change and thus the bridge is free from any temperature effects from the long lead wires leading from the circuit to the location of the metal foil strain gage near the distal tip of the catheter. The temperature effect of the third lead wire  
5 connected to the amplifier can be ignored since the amplifier provides a high impedance input connection. With the three-wire system each lead wire must be of the same material, wire gage and length for proper temperature compensation purposes. Temperature effects on gage resistance and gage factor may not require compensation since most metallic gage alloys exhibit a nearly linear gage factor  
10 variation with temperature over a broad range which is less than  $\pm 1\%$  within  $\pm 100^\circ\text{C}$  temperature range. Each strain gage wire material has its characteristic gage factor, resistance, temperature coefficient of gage factor, thermal coefficient of resistivity, and stability. Materials that may be used for strain gage construction include constantan, nichrome, platinum alloys, isoelastic (nickel-iron alloy), and karma-type  
15 alloy wires (nickel-chrome alloy). To double the bridge output for the same strain it may be useful to connect gages that are on opposite sides of a beam, one in compression and the other in tension.

[0068] A high-resolution analog-to-digital converter (ADC) **502** that includes  
20 differential inputs, programmable internal amplifiers, automatic zero calibration, high common-mode rejection, and digital noise filtering to aid in the strain sensor integration and to accurately measure bridge circuit voltage output. The output of the ADC **502** is communicated to the microprocessor **504** which perform the calculation set forth above to determine the strain.

25

[0069] In the elastic region of a stress-strain curve, the stress is linearly proportional to strain. The catheter tip is used in the elastic region so the tip is not permanently deformed, as this would cause the strain sensors not return to zero strain since the material that they are bonded would have yielded. Since the catheter is used in the  
30 linear region of the stress strain curve, the strain value is directly proportional and can be converted to the stress on the strut member in multiple orientations. The catheter tip has three different types of stresses acting upon it: Bending moment



induced stress, torsional stress and shear stress which may be negligible compared to the other two stress components. By calibrating each catheter with different three-dimensional tip force vectors, the tip forces (grams) can be determined based upon the strain value from each strain gage and their corresponding placement orientation  
5 with respect to the strut.

[0070] The preceding description has been presented with reference to presently preferred embodiments of the invention. Workers skilled in the art and technology to which this invention pertains will appreciate that alterations and changes in the described structure may be practiced without meaningfully departing from the principal, spirit and scope of this invention.  
10

[0071] Accordingly, the foregoing description should not be read as pertaining only to the precise structures described and illustrated in the accompanying drawings, but rather should be read consistent with and as support to the following claims which are to have their fullest and fair scope.  
15

[0072] Throughout this specification and the claims which follow, unless the context requires otherwise, the word "comprise", and variations such as "comprises" and "comprising", will be understood to imply the inclusion of a stated integer or step or group of integers or steps but not the exclusion of any other integer or step or group of integers or steps.  
20

[0073] The reference to any prior art in this specification is not, and should not be taken as, an acknowledgment or any form or suggestion that the prior art forms part of the common general knowledge in Australia.  
25

## Claims:

1. A force-sensing catheter having a longitudinal axis for use in a vessel including:
- 5 an elongate tubular member having a proximal end and a distal end, the distal end including a deflectable tip portion termination in a distal tip, the elongate tubular member having a central lumen disposed through the proximal end and two half-cylindrical lumens in the deflectable tip portion;
- a tip electrode disposed at the distal tip of the deflectable tip portion;
- 10 a center strut having a rectangular beam section along the longitudinal axis extending from near the proximal end of the tip electrode through the deflectable tip portion of the elongate tubular member and having a first longitudinal edge and a second longitudinal edge and a first side and a second side wherein the width of the first side and the second side are greater than the width of the first longitudinal edge
- 15 and the second longitudinal edge respectively;
- wherein the center strut is bonded to the elongate tubular member substantially along entire length of the first longitudinal edge and the second longitudinal edge to form the two half-cylindrical lumens and create an inseparable composite structure from the center strut and the elongate tubular member; and,
- 20 at least one strain gage, the at least one strain gage affixed to only the first side or the second side of the center strut, the at least one strain gage oriented and configured to detect a bending strain or a torsional strain in the center strut for measuring force near the distal end of the tubular member.
- 25 2. The force-sensing catheter of claim 1 wherein a first strain gage and a second strain gage each having a strain measuring component are affixed to either the first side or the second side of the center strut with the strain measuring component of the first strain gage perpendicular to the strain measuring component of the second strain gage and the strain measuring component of each at a forty-five
- 30 degree angle to the longitudinal axis of the catheter for measuring torsional strain on the distal tip of the catheter.

3. The force-sensing catheter of claim 1 wherein the strain gage having a strain measuring component is affixed to either the first side or the second side of the center strut so that the strain measuring component is axially aligned with the longitudinal axis of the catheter for measuring bending strain on the distal tip of the catheter.
- 5
4. The force-sensing catheter of claim 1 wherein a first strain gage and a second strain gage each having a strain measuring component are affixed to either the first side or the second side of the center strut with the strain measuring component of the first strain gage perpendicular to the strain measuring component of the second strain gage and the strain measuring component of each at a forty-five degree angle to the longitudinal axis of the catheter for measuring torsional strain on the distal tip of the catheter and a third strain gage having a strain measuring component is affixed to either the first side or the second side of the center strut so that the strain measuring component is axially aligned with the longitudinal axis of the catheter for measuring bending strain on the distal tip of the catheter.
- 10
- 15
5. The force-sensing catheter of claim 1 wherein the strain gage is a semiconductor strain gage.
- 20
6. The force-sensing catheter of claim 5 wherein the semiconductor strain gage is silicon based.
7. The force-sensing catheter of claim 5 wherein a table of offset temperature variations in sensed strain due to changes in the temperature of the environment in which the catheter is used.
- 25
8. The force-sensing catheter of claim 1 wherein the strain gage is a metallic foil strain gage.
- 30

9. The force-sensing catheter of claim 2 wherein the width of the center strut is narrowed parallel to where the first and second strain gages are affixed in order to amplify the torsional strain.
- 5 10. The force-sensing catheter of claim 3 further including at least one slot cut into the center strut near the strain gage, the slot configured to amplify the bending strain.
11. The force-sensing catheter of claim 1 wherein the center strut has been  
10 thermally bonded to the elongate tubular member substantially along the entire length of the center strut.
12. The force-sensing catheter of claim 1 further including a pull wire, having a proximal end and a distal end, for causing the deflectable distal portion of the  
15 elongate tubular member to deflect wherein the proximal end of the pull wire is attached to a control handle at the distal end of the catheter.
13. The force-sensing catheter of claim 12 wherein the distal end of the pull  
20 wire is attached to the tip electrode.
14. The force-sensing catheter of claim 1 further including a first pull wire and a second pull wire, each having a proximal end and a distal end, wherein the proximal end of the first and second pull wires are attached to a control handle and the distal end of the first pull wire is attached to the first side of the center strut and the distal  
25 end of the second pull wire is attached to the second side of the center strut.
15. The force-sensing catheter of claim 14 wherein the center strut includes at least one anchor hole for attachment of the distal ends of the first and second pull  
30 wires.

16. The force-sensing catheter of claim 14 wherein the center strut includes a plurality of anchor holes longitudinally spaced along the length of the center strut for attachment of the distal end of the first and second pull wires.
- 5 17. The force-sensing catheter of claim 16 wherein the plurality of anchor holes are spaced from adjacent anchor holes by approximately 0.078 inch.
18. The force-sensing catheter of claim 16 wherein the anchor holes are approximately 0.015 inch in diameter.
- 10 19. The force-sensing catheter of claim 1 further including a first pull wire and a second pull wire each having a proximal end and a distal end, wherein the proximal ends of the first and second pull wires are attached to a control handle and the distal ends of the first and second pull wires are attached to the tip electrode.
- 15 20. The force-sensing catheter of claim 19 wherein the tip electrode has a hollow portion and a plug and the distal ends of the first and second pull wires are attached to the plug prior to insertion in the hollow portion.
- 20 21. The force-sensing catheter of claim 1 further including a temperature sensor.
22. The force-sensing catheter of claim 21 wherein the temperature sensor is configured to provide an indication of the temperature of the tip of the catheter for use in temperature compensation of the output of the strain gage.
- 25 23. The catheter of claim 1 further including a location sensor.
24. The catheter of claim 1 wherein the tip electrode has irrigation ports and the catheter further includes an irrigation lumen in communication with the irrigation
- 30 ports.

25. The catheter of claim 1 further including a first pull wire and a second pull wire each having a proximal end and a distal end, wherein the proximal ends of the first and second pull wires are attached to a control handle and the distal ends of the first and second pull wires are attached to anchors and are threaded through first and second holes in the tubular member.
26. The catheter of claim 1 wherein the tubular member has an inner layer, a braided layer and an outer layer and wherein the first longitudinal edge and the second longitudinal edge of the center strut is thermally bonded to the inner layer.
27. The catheter of claim 1 wherein the center strut has been roughened along the first longitudinal edge and the second longitudinal edge to improve bonding with the tubular member.
28. The catheter of claim 1 further including a molded coupling adapted to receive the proximal end portion of the tip electrode.
29. The catheter of claim 28 wherein the distal end of the center strut includes at least one snap-fit notch and the molded coupling further includes at least one snap-fit wedge adapted to receive the snap-fit notch.
30. The catheter of claim 28 wherein the molded coupling further includes at least one slot adapted to receive at least one of the first or second longitudinal edges of the distal portion of the center strut.
31. A catheter for use in a vessel including:  
an elongate tubular member having a proximal end and a distal end, the distal end including a deflectable tip portion terminating in a distal tip, the elongate tubular member having a central lumen disposed through the proximal end and two half-cylindrical lumens in the deflectable tip portion;  
a tip electrode disposed at the distal tip of the deflectable tip portion;

a center strut having a rectangular beam section extending from near the proximal end of the tip electrode through the deflectable tip portion of the elongate tubular member and having a first longitudinal edge and a second longitudinal edge and a first side and a second side;

5 a molded coupling having a distal portion adapted to receive a portion of the proximal end of the tip electrode and having a proximal portion having at least one slot adapted to receive the distal end of at least one of the first or second longitudinal edges of the center strut, the molded coupling defining a quick assembly mechanism;

wherein the center strut is bonded to the elongate tubular member  
10 substantially along entire length of the first longitudinal edge and the second longitudinal edge to form the two half-cylindrical lumens and create an inseparable composite structure of the center strut and the elongate tubular member and,

at least one strain gage, the at least one strain gage affixed to only one of the first side and/or the second side of the center strut, the at least one strain gage  
15 oriented and configured to detect the bending strain or torsional strain in the center strut for measuring force near the distal end of the tubular member.

32. The catheter of claim 31 wherein the distal end of the center strut includes at least one snap-fit notch and the molded coupling further includes at least one snap-fit  
20 wedge adapted to receive the snap-fit notch.

33. The force-sensing catheter of claim 31 wherein a first strain gage and a second strain gage each having a strain measuring component affixed to either the first side and/or the second side of the center strut with the strain measuring  
25 component of the first strain gage perpendicular to the strain measuring component of the second strain gage and the strain measuring component of each at a forty-five degree angle to the longitudinal axis of the catheter for measuring torsional strain on the distal tip of the catheter.

30 34. The force-sensing catheter of claim 31 wherein the strain gage having a strain measuring component is affixed to either the first side or the second side of the center strut so that the strain measuring component is axially aligned with the

longitudinal axis of the catheter for measuring bending strain on the distal tip of the catheter.

5 35. The force-sensing catheter of claim 31 wherein a first strain gage and a second strain gage each having a strain measuring component are affixed to either the first side or the second side of the center strut with the strain measuring component of the first strain gage perpendicular to the strain measuring component of the second strain gage and the strain measuring component of each at a forty-five degree angle to the longitudinal axis of the catheter for measuring torsional strain on 10 the distal tip of the catheter and a third strain gage having a strain measuring component is affixed to either the first side or the second side of the center strut so that the strain measuring component is axially aligned with the longitudinal axis of the catheter for measuring bending strain on the distal tip of the catheter.

15 36. The force-sensing catheter of claim 1 wherein the output of the strain gage is used to calculate the sensed force in accordance with the following equation:

$$V_{OUT} = V_B \times (S \times S_0 \times (1 + S_1 \times (T - T_r)) + U_0 + U_1 \times (T - T_r))$$

where  $V_{OUT}$  is the bridge voltage output,  $V_B$  is the bridge excitation voltage,  $S$  is the applied sensor strain,  $T_r$  is the reference temperature measured near the silicon strain 20 sensor,  $S_0$  is the strain gage sensitivity at reference temperature  $T_r$ ,  $S_1$  is the temperature coefficient of sensitivity (TCS),  $U_0$  is the offset or unbalance of the bridge at  $T_r$  with no strain applied, and  $U_1$  is the offset temperature coefficient (OTC).

25



FIG. 1A

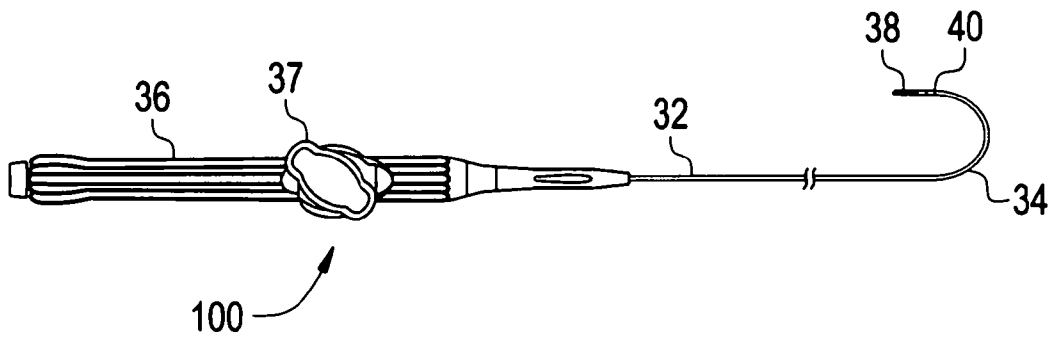

FIG. 1B

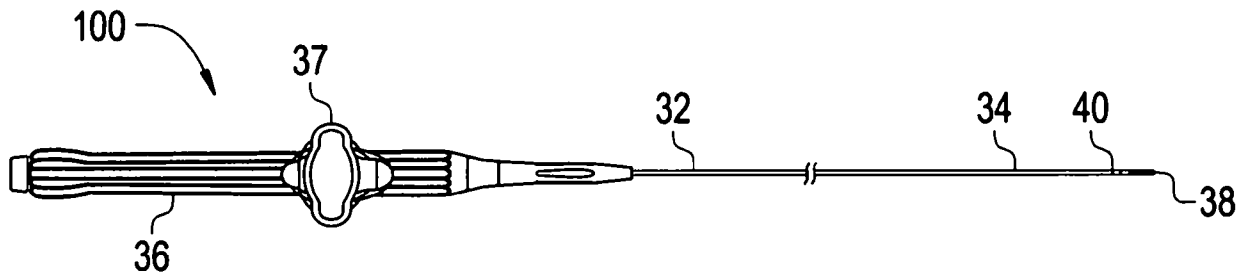

FIG. 1C

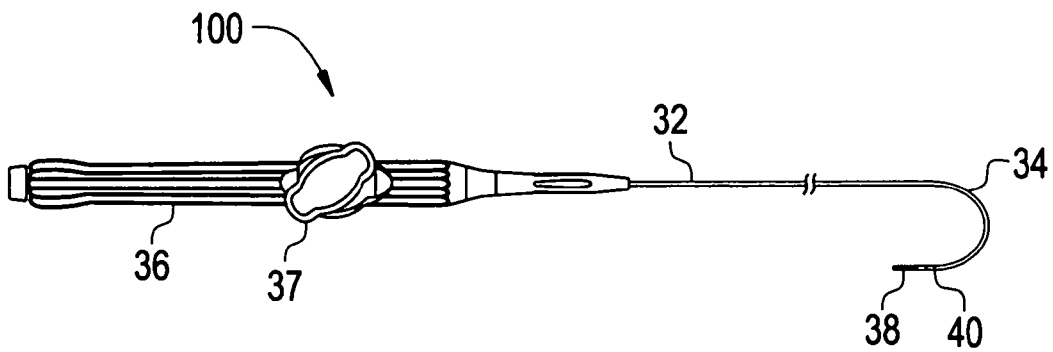

FIG. 1D

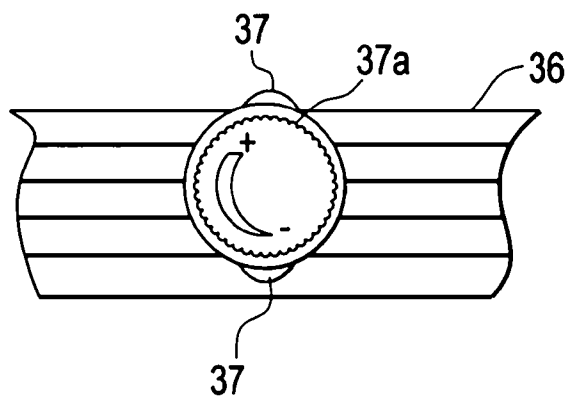

FIG. 2

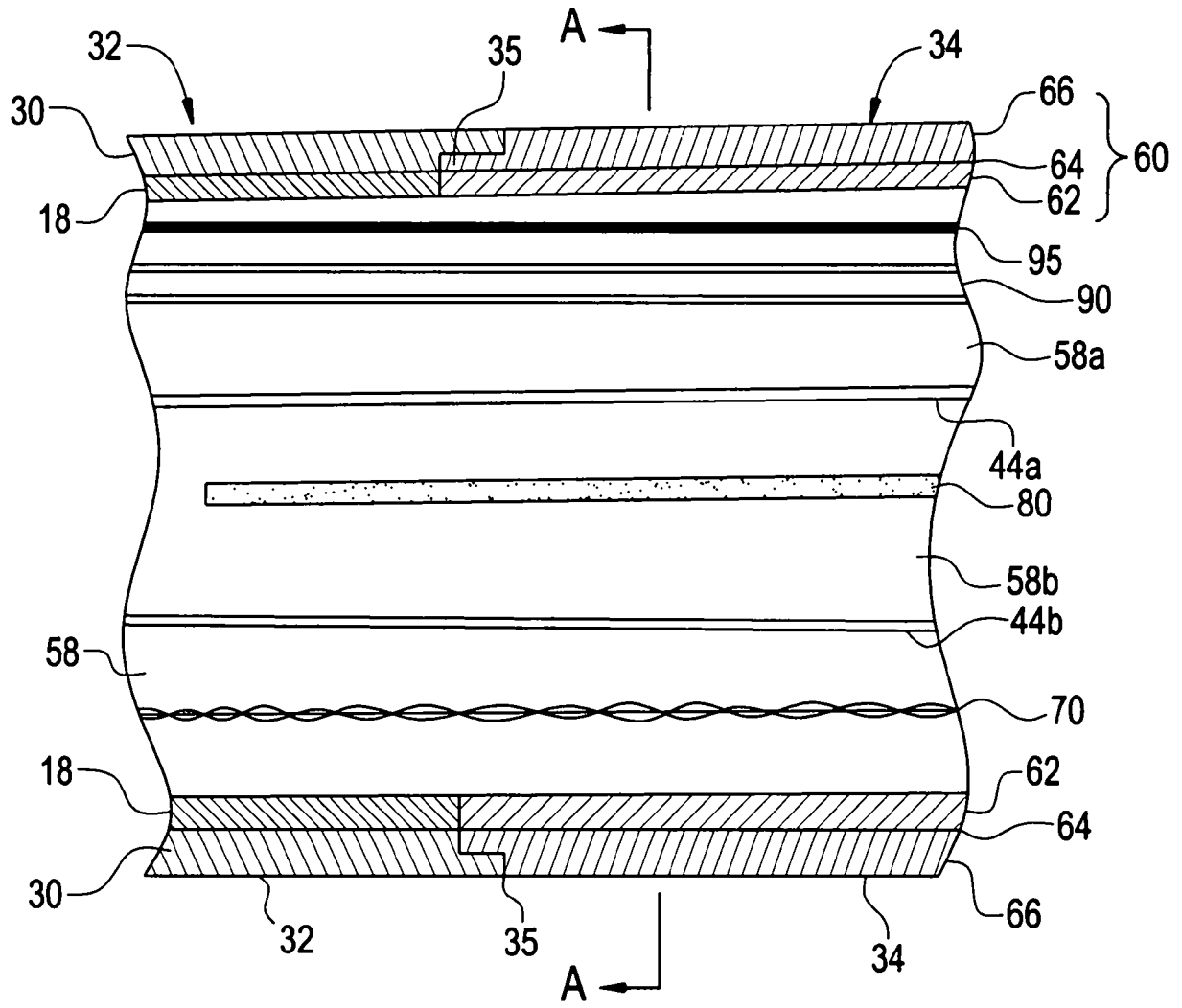

FIG. 3

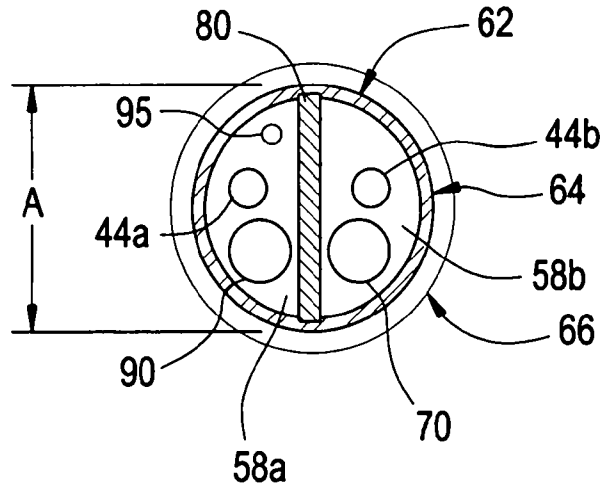

FIG. 4

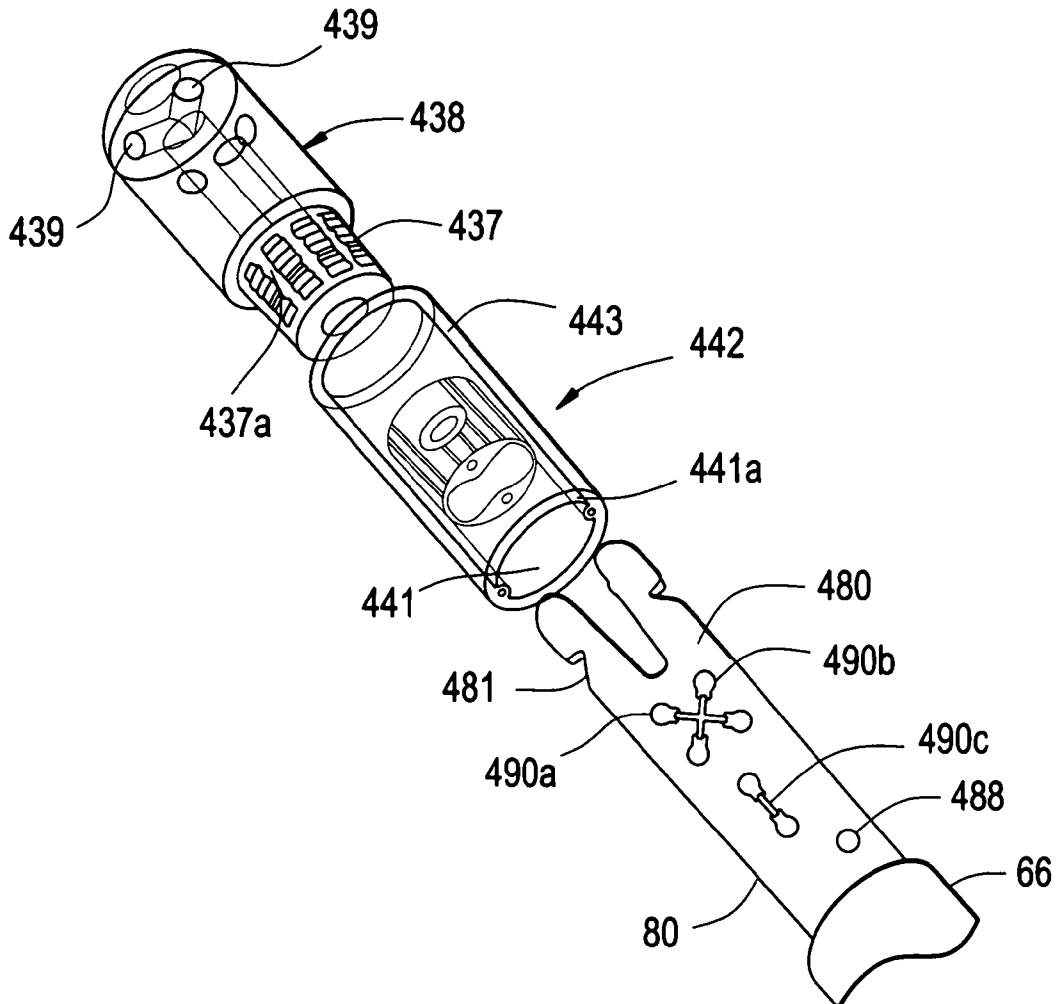

FIG. 5

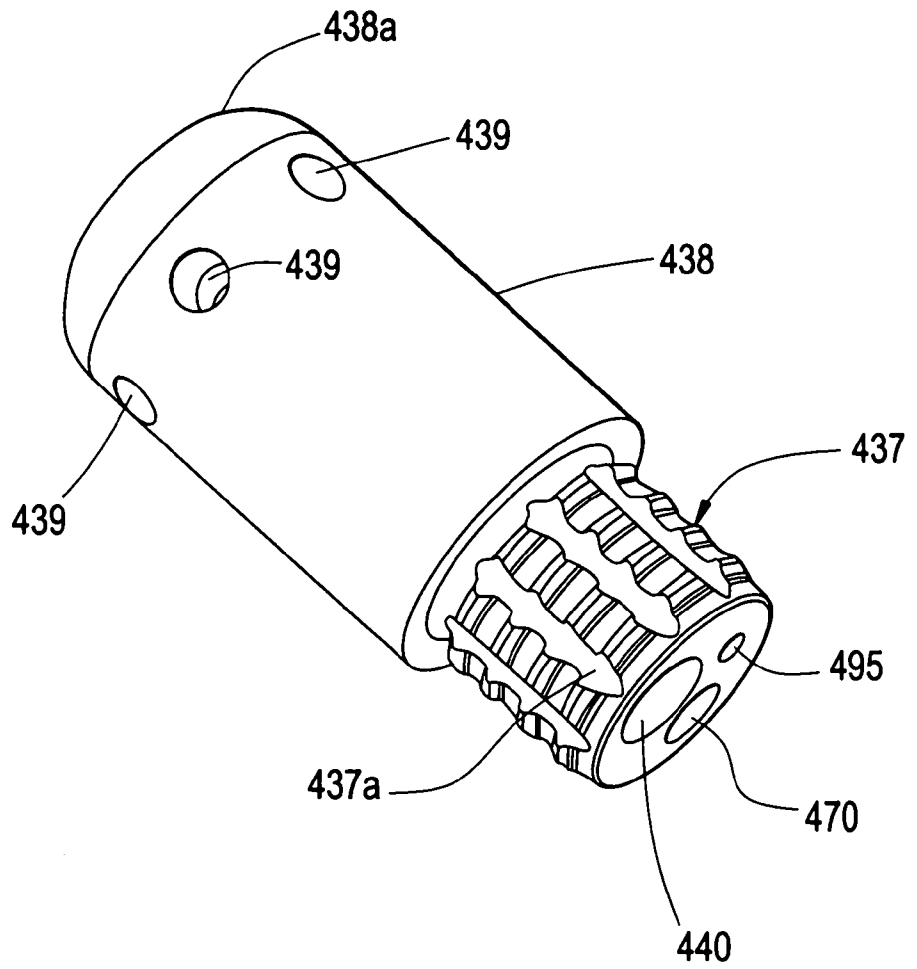

FIG. 6

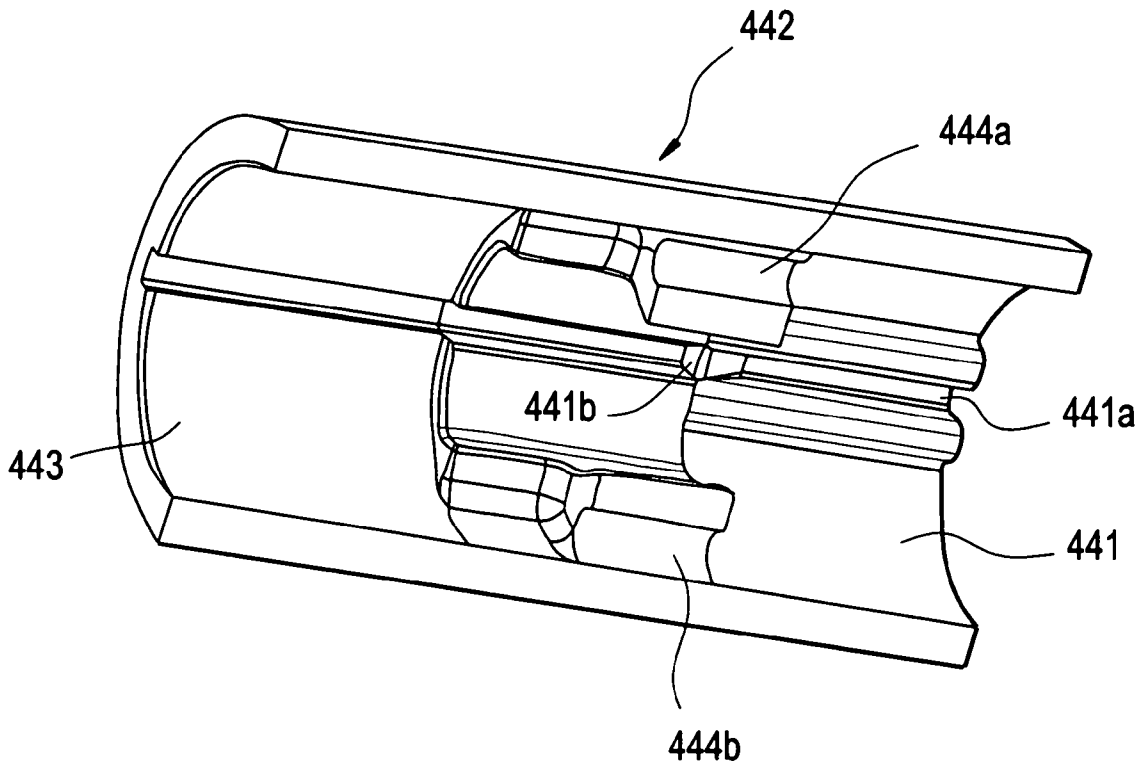

FIG. 7A

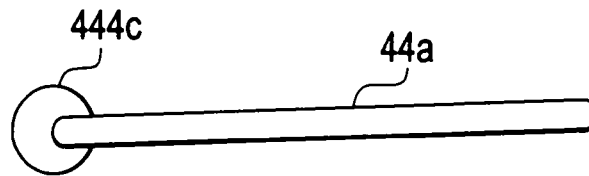

FIG. 7B

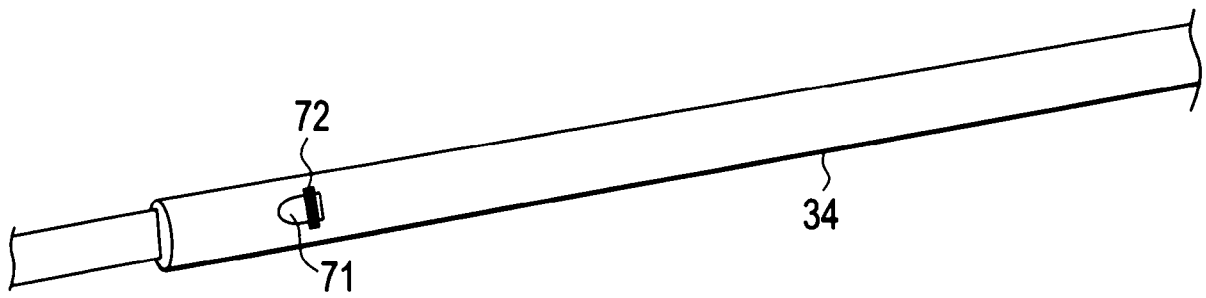

FIG. 8

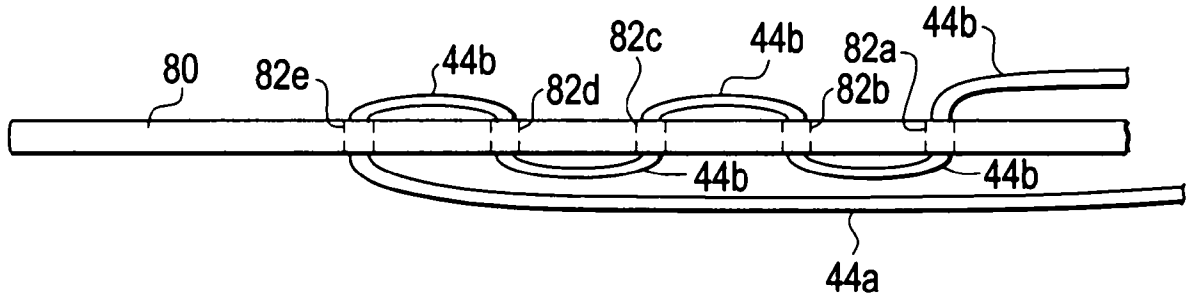

FIG. 9

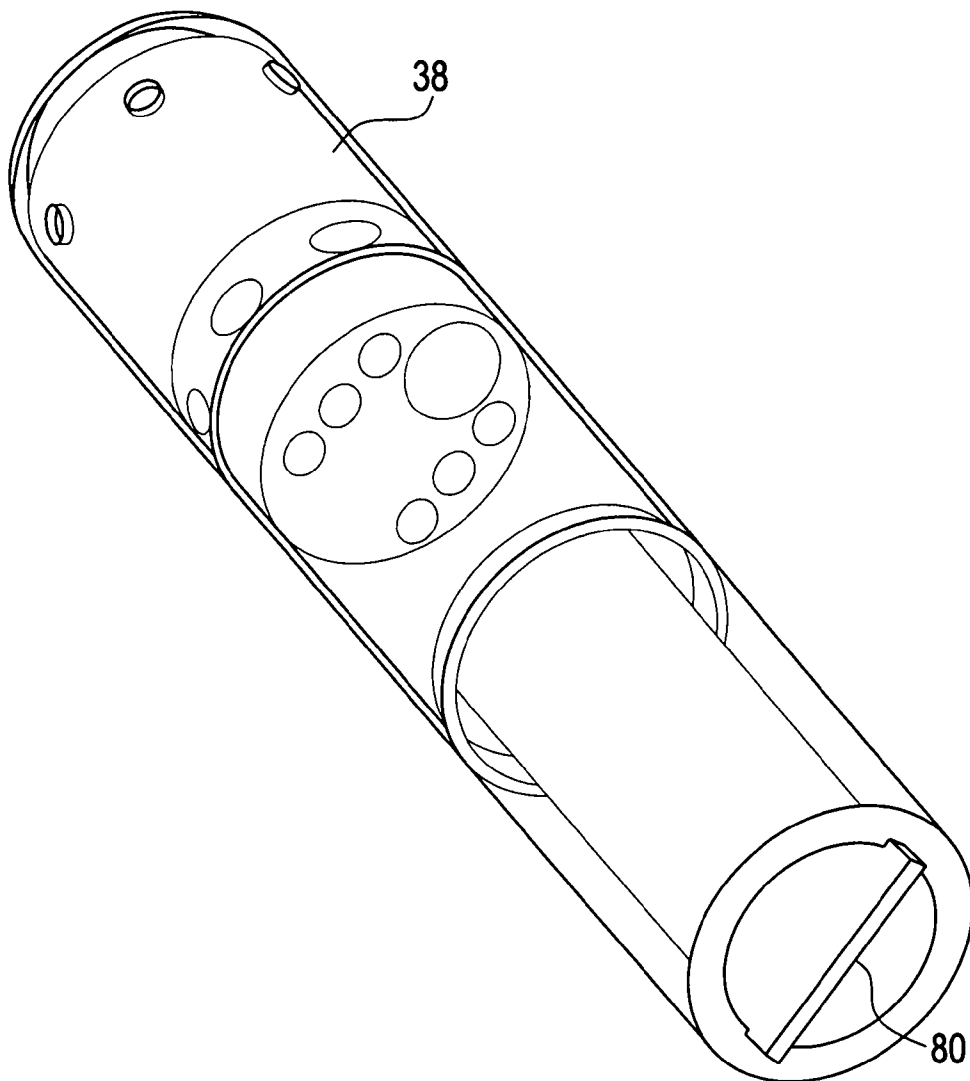

FIG. 10

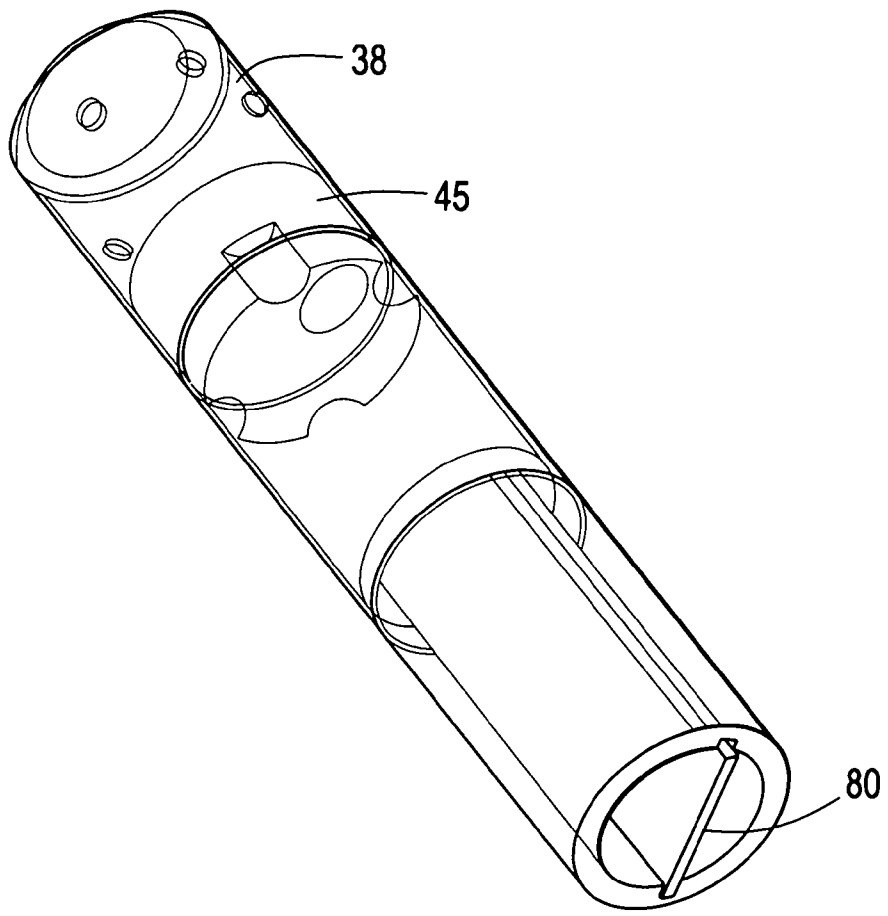



FIG. 11

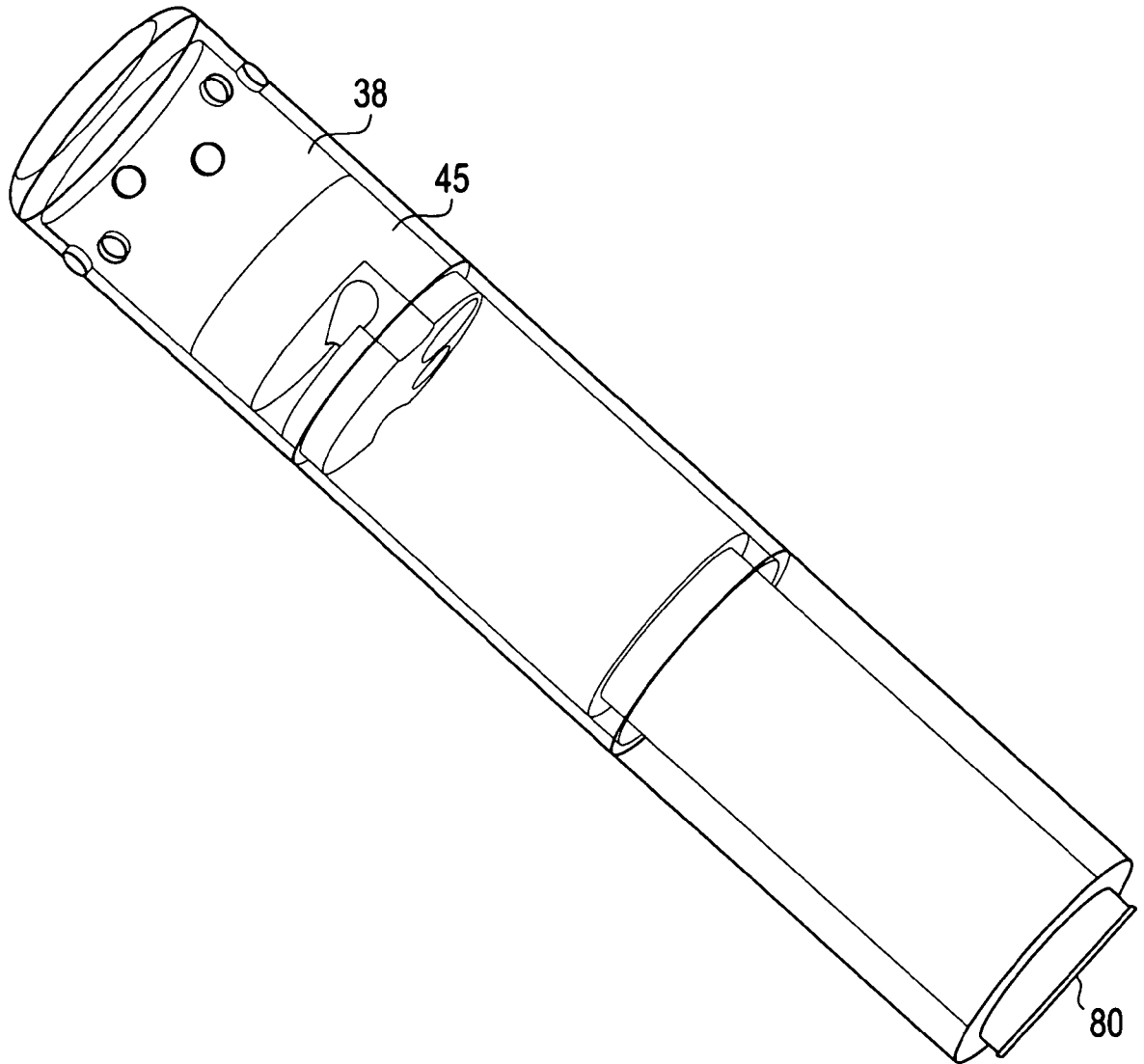

FIG. 12

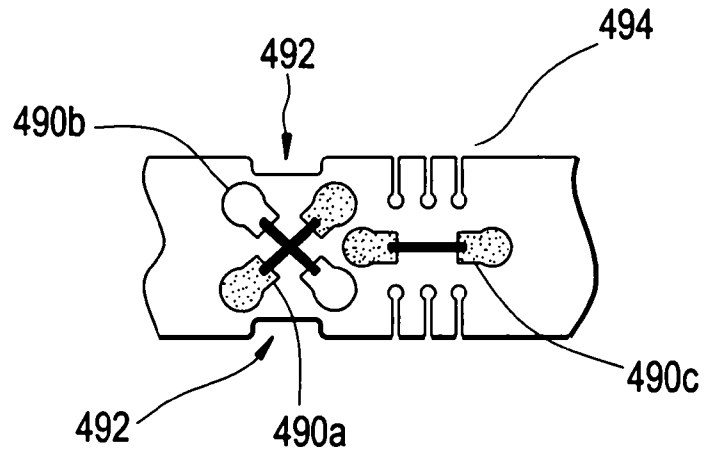

FIG. 13

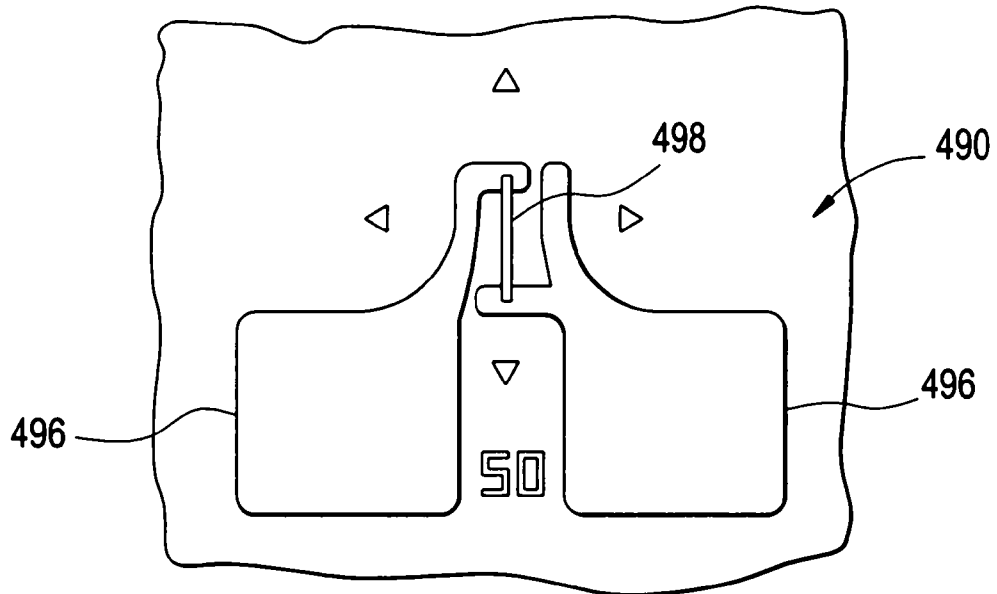

FIG. 14

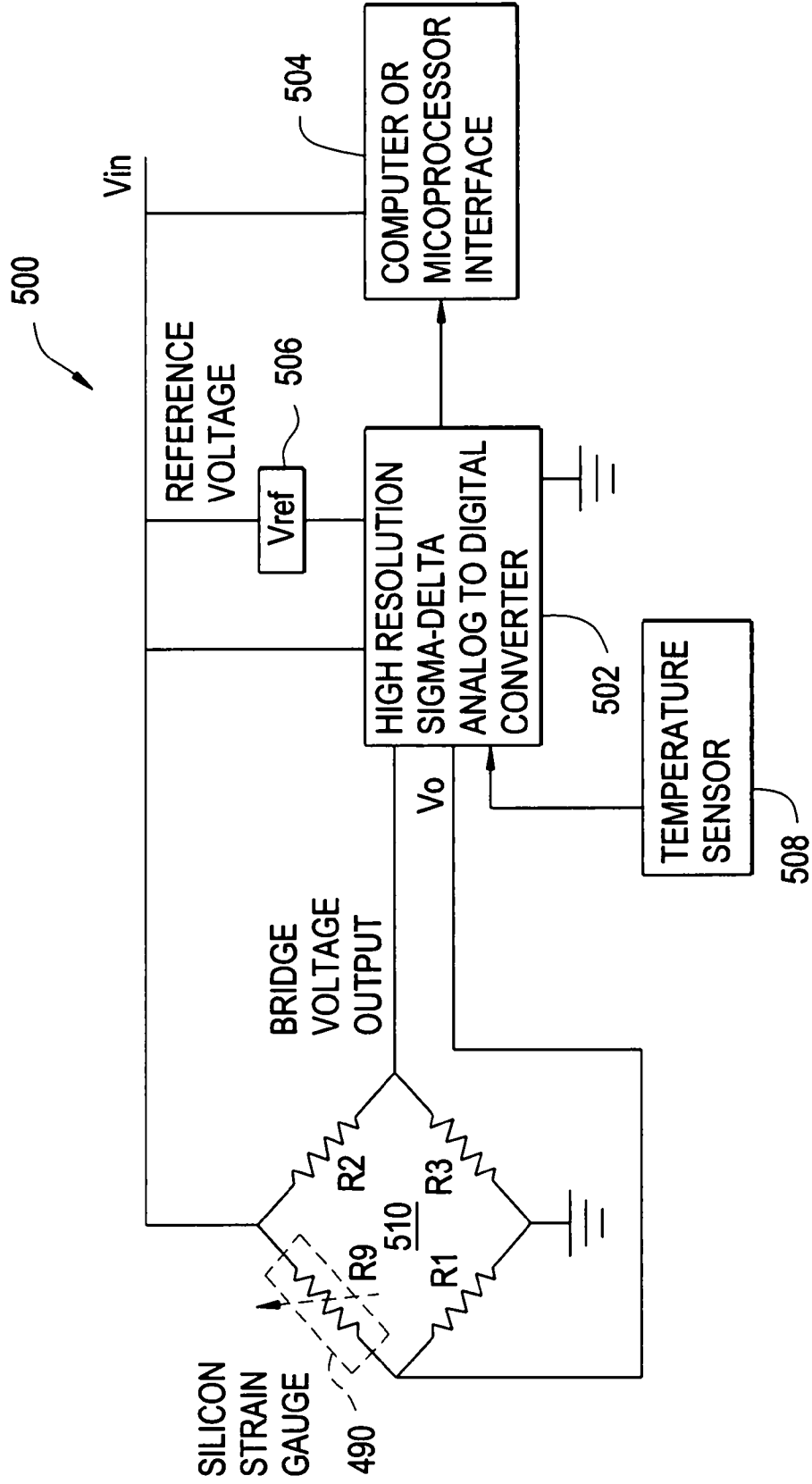

FIG. 15

