



US00RE41717E

(19) **United States**  
(12) **Reissued Patent**  
**Dejaeger**

(10) **Patent Number:** **US RE41,717 E**  
(45) **Date of Reissued Patent:** **Sep. 21, 2010**

(54) **APPARATUS AND METHOD FOR OPERATING A CHECKOUT SYSTEM HAVING A DISPLAY MONITOR WHICH DISPLAYS BOTH TRANSACTION INFORMATION AND CUSTOMER-SPECIFIC MESSAGES DURING A CHECKOUT TRANSACTION**

4,676,343 A 6/1987 Humble et al.  
4,679,154 A 7/1987 Blanford  
4,715,457 A 12/1987 Amacher et al.

(Continued)

FOREIGN PATENT DOCUMENTS

(75) Inventor: **Wilfried E. Y. Dejaeger**, Brussels (BE)

BE 899018 6/1984

(73) Assignee: **NCR Corporation**, Duluth, GA (US)

(Continued)

OTHER PUBLICATIONS

(21) Appl. No.: **10/667,246**

(22) Filed: **Sep. 18, 2003**

Amato-McCoy, Deena, "Brookshire's Shoppers Will Soon Experience Ease and Convenience of NCR Self-Checkout; NCR Self-Checkout Express Lets Shoppers Scan and Pay for Their Purchases", PR Newswire, Feb. 24, 1999.

**Related U.S. Patent Documents**

Reissue of:

(64) Patent No.: **6,296,185**  
Issued: **Oct. 2, 2001**  
Appl. No.: **09/432,639**  
Filed: **Nov. 2, 1999**

(Continued)

(51) **Int. Cl.**  
**G06K 15/00** (2006.01)

*Primary Examiner*—Edwyn Labaze  
(74) *Attorney, Agent, or Firm*—Peter Priest, Esq.

(52) **U.S. Cl.** ..... **235/383; 235/385; 186/59; 186/61**  
(58) **Field of Classification Search** ..... **235/383, 235/381, 378, 375, 380, 385, 470, 487; 186/59, 186/61; 705/10, 14, 16, 1**  
See application file for complete search history.

(57) **ABSTRACT**

A method of operating a retail terminal having a display monitor includes the step of generating an item-entered control signal when an item for purchase of a customer is entered into the retail terminal by retail personnel. The method also includes the step of retrieving retail history information associated with the customer from a customer profile database. The method further includes the step of displaying item information associated with the item for purchase on a first portion of the display monitor in response to generation of the item-entered control signal. Moreover, the method includes the step of displaying a customer-specific retail message based on the retail history information on a second portion of the display monitor. The step of displaying the customer-specific retail message is performed contemporaneously with the step of displaying the item information associated with the item for purchase. A retail terminal is also disclosed.

(56) **References Cited**

U.S. PATENT DOCUMENTS

3,182,357 A 5/1965 Tuttle  
3,688,873 A 9/1972 Potrafke  
3,725,895 A 4/1973 Haynes  
3,836,755 A 9/1974 Ehrat  
3,878,365 A 4/1975 Schwartz  
4,071,740 A 1/1978 Gogulski  
4,084,742 A 4/1978 Silverman  
4,373,133 A 2/1983 Clyne et al.  
4,583,083 A 4/1986 Bogasky  
4,583,619 A 4/1986 Fry

**53 Claims, 31 Drawing Sheets**

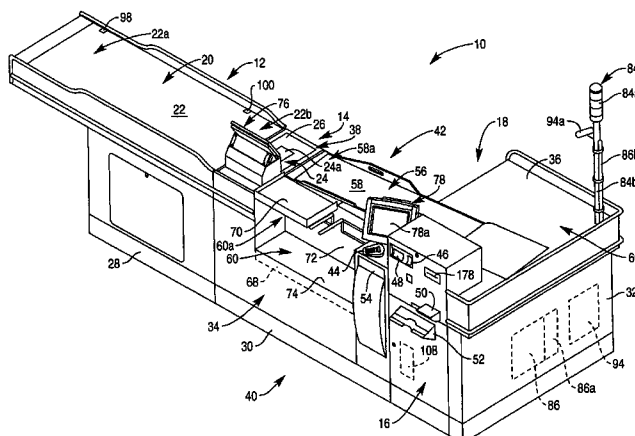

## U.S. PATENT DOCUMENTS

4,775,782 A 10/1988 Mergenthaler et al.  
 4,779,706 A 10/1988 Mergenthaler  
 4,787,467 A 11/1988 Johnson  
 4,789,048 A 12/1988 Cramer et al.  
 4,792,018 A 12/1988 Humble et al.  
 4,825,045 A 4/1989 Humble et al.  
 4,909,356 A 3/1990 Rimondi et al.  
 4,929,819 A 5/1990 Collins, Jr.  
 4,940,116 A 7/1990 O'Connor et al.  
 4,947,028 A 8/1990 Gorog  
 4,964,053 A 10/1990 Humble  
 5,004,916 A 4/1991 Collins, Jr.  
 5,040,636 A 8/1991 Forsythe et al.  
 5,083,638 A 1/1992 Schneider  
 5,115,888 A 5/1992 Schneider  
 5,125,465 A 6/1992 Schneider  
 5,168,961 A 12/1992 Schneider  
 5,174,413 A 12/1992 Cappi et al.  
 5,191,749 A 3/1993 Cappi et al.  
 5,250,789 A 10/1993 Johnsen  
 5,297,030 A 3/1994 Vassigh et al.  
 5,315,097 A 5/1994 Collins, Jr. et al.  
 5,340,970 A 8/1994 Wolfe, Jr. et al.  
 5,343,025 A 8/1994 Usui  
 5,345,071 A 9/1994 Dumont  
 5,361,871 A 11/1994 Gupta et al.  
 5,375,680 A 12/1994 Ikeda et al.  
 5,378,860 A 1/1995 Dingfelder et al.  
 5,397,882 A 3/1995 Van Solt  
 5,398,191 A 3/1995 Komai  
 5,424,524 A 6/1995 Ruppert et al.  
 5,426,282 A 6/1995 Humble  
 5,426,423 A 6/1995 Raimbault et al.  
 5,434,394 A 7/1995 Roach et al.  
 5,437,346 A 8/1995 Dumont  
 5,448,046 A 9/1995 Swartz  
 5,457,307 A 10/1995 Dumont  
 5,478,989 A 12/1995 Shepley  
 5,484,991 A 1/1996 Sherman et al.  
 5,485,006 A 1/1996 Allen et al.  
 5,489,773 A 2/1996 Kumar  
 5,494,136 A 2/1996 Humble  
 5,497,314 A 3/1996 Novak  
 5,497,853 A 3/1996 Collins, Jr. et al.  
 5,540,301 A 7/1996 Dumont  
 5,543,607 A 8/1996 Watanabe et al.  
 5,544,040 A 8/1996 Gerbaulet  
 5,560,450 A 10/1996 Kouno  
 5,595,264 A 1/1997 Trotta, Jr.  
 5,609,223 A 3/1997 Iizaka et al.  
 5,635,906 A 6/1997 Joseph  
 5,637,847 A 6/1997 Watanabe  
 5,662,190 A 9/1997 Abe  
 5,663,963 A 9/1997 Goodwin, III et al.  
 5,684,289 A 11/1997 Detwiler et al.  
 5,708,782 A 1/1998 Larson et al.  
 5,721,420 A 2/1998 May  
 5,736,721 A 4/1998 Swartz  
 5,747,784 A 5/1998 Walter et al.  
 5,752,582 A 5/1998 Hayward  
 5,814,799 A 9/1998 Swartz et al.  
 5,821,512 A 10/1998 O'Hagan et al.  
 5,832,457 A 11/1998 O'Brien et al.  
 5,845,259 A 12/1998 West et al.  
 5,845,263 A 12/1998 Camaisa et al.  
 5,877,485 A 3/1999 Swartz  
 5,883,968 A 3/1999 Welch et al.  
 5,884,281 A 3/1999 Smith et al.  
 5,884,728 A 3/1999 d'Estaintot et al.  
 5,890,135 A 3/1999 Powell

5,898,158 A 4/1999 Shimizu et al.  
 5,900,614 A 5/1999 Nakakawaji et al.  
 5,918,211 A \* 6/1999 Sloane ..... 705/16  
 5,923,735 A 7/1999 Swartz et al.  
 5,978,772 A 11/1999 Mold  
 6,055,573 A 4/2000 Gardenswartz  
 6,932,270 B1 \* 8/2005 Fajkowski ..... 235/383

## FOREIGN PATENT DOCUMENTS

DE 1927819 2/1971  
 DE 2125869 12/1972  
 DE 3114139 A1 11/1982  
 DE 3330301 A1 3/1985  
 EP 0060701 B1 9/1982  
 EP 0124355 B1 11/1984  
 EP 0178223 A2 4/1986  
 EP 0491348 A2 6/1992  
 EP 0811958 A2 12/1997  
 EP 0905656 A2 3/1999  
 EP 0905658 A1 3/1999  
 EP 0953947 A2 3/1999  
 EP 0953948 A2 3/1999  
 EP 0991006 A 4/2000  
 GB 2068132 A 8/1981  
 GB 2285687 A 7/1995  
 JP 5314367 11/1993  
 WO WO 93/16443 A 8/1993  
 WO WO 98/38589 A 9/1998

## OTHER PUBLICATIONS

Amato-McCoy, Deena, "Self-Checkout Test Planned at Brookshire Grocery Units", Supermarket News p. 21(1), Apr. 26, 1999.

"More Supermarkets Can Offer Shoppers Ease and Convenience of NCR Self-Checkout", PR Newswire, Feb. 16, 1999.

Power, Denise, "Self-Scanning Checks In. (Meijer)", HFN The Weekly Newspaper for the Home Furnishing Network, vol. 72, Issue No. 36, Sep. 14, 1998.

Web pages: <http://www.terrigal.net.au/kjka/www.pscnet.com/uscanse.htm>, U-Scan Express(tm) Self-Checkout, Mar. 29, 2000.

Zimmerman, Kim Ann, "Food Lion to Install More Self-Checkouts", Supermarket News, Oct. 4, 1999.

"NCR: NCR Unveils Retail Self-Service Solution", M2 Presswire, Jun. 16, 1998.

Corbin, Cole, "Checking Out Self-Scanning: More Retailers are Singing the Praises of Both Portable and Stationary Self-Scanning, but Customers Still Need a Bit of Wooing", Supermarket News, Mar. 15, 1999.

Moltzen, Edward F., "NCR, Innovax Team for Supermarket Sweep", Computer Reseller News, Feb. 22, 1999.

Abstract: Woodyard, Chris, "Grocery Shoppers can be Own Cashiers", USA Today, Mar. 9, 1998.

Search Results List: 8 Articles listed; Word or Phrase: Self and (checkout or scan?) and automat? and teller and mach, Date range: 1998—Present; print date Apr. 3, 2000.

Search Results List: 7 Articles listed; Word or Phrase: Self and (checkout or scan?) and automat? and teller and mach, Date range: Backfile (1986—1997); print date Apr. 3, 2000.

Search Results List by Rank: 100 Articles listed; Search criteria Self-Checkout Coupled to an Automated Teller Machine; print date Mar. 29, 2000.

U-Scan Express.TM., The U-Scan Express.TM. Self-Checkout System, Spectra-Physics Scanning Systems, Inc., Feb. 1996.

Optimal Robotics 8870 System. TM., Optimal Robotics Corporation, 1995.

Zimmerman, Denise, "Kroger Unit to Expand Customer Self-Scanning", Supermarket News, Aug. 14, 1995, p. 15.

Zimmerman, Denise, "Kroger Self-Scan Lane To Test Debit Credit", Supermarket News, vol. 45, No. 14, p. 13+, Apr. 3, 1995.

Lang Jones, Jeanne, "Robots Will Do Checkout at grocery", Houston Post, (Final, Business, p. C1, Feb. 22, 1995.

"Burger King Tests Credit-Card Payments", The Miami Herald Knight-Rider/Tribune Business News, Jul. 9, 1993.

Wisemberg-Brin, Dinah, Associated Press, "You-buy, you-scan bag", Dayton Daily News, Aug. 11, 1996.

Gamburer, A.T., et al., "Analogue-code Converter Used with Strain Gauge Hopper Weighers", Instrumental and Control, Mar. 3, 1969.

\* cited by examiner

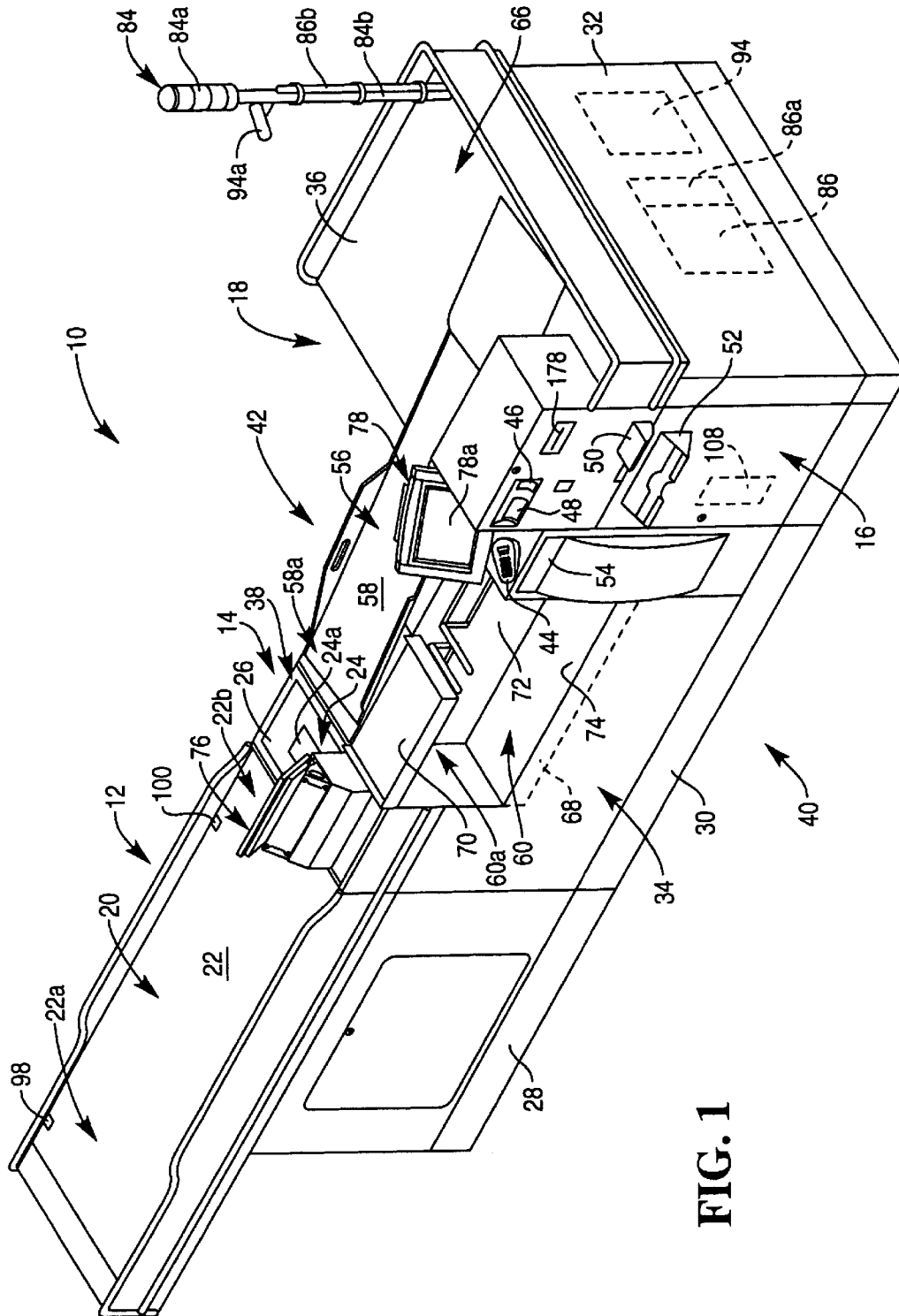

FIG. 1

FIG. 2

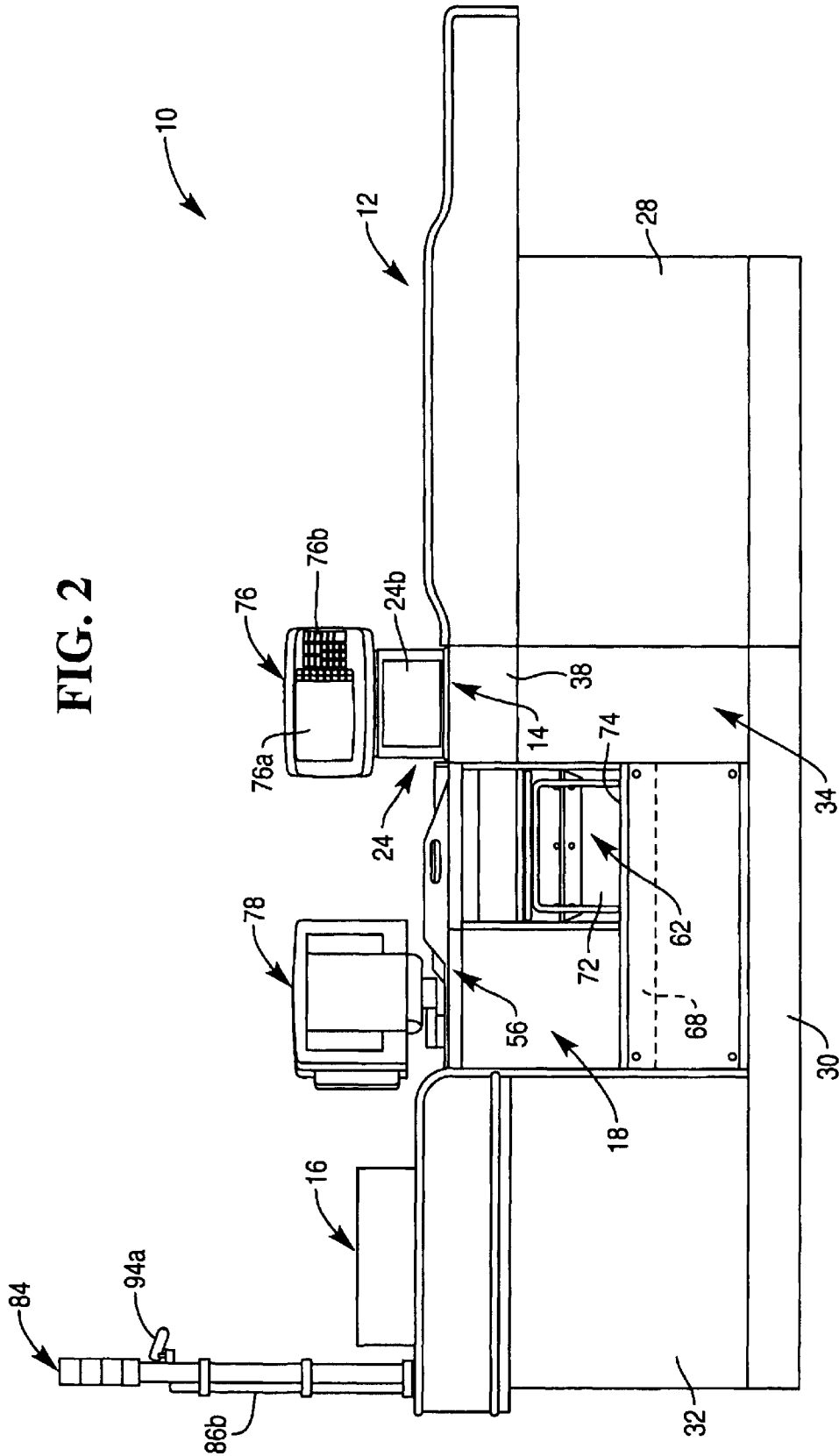

FIG. 3

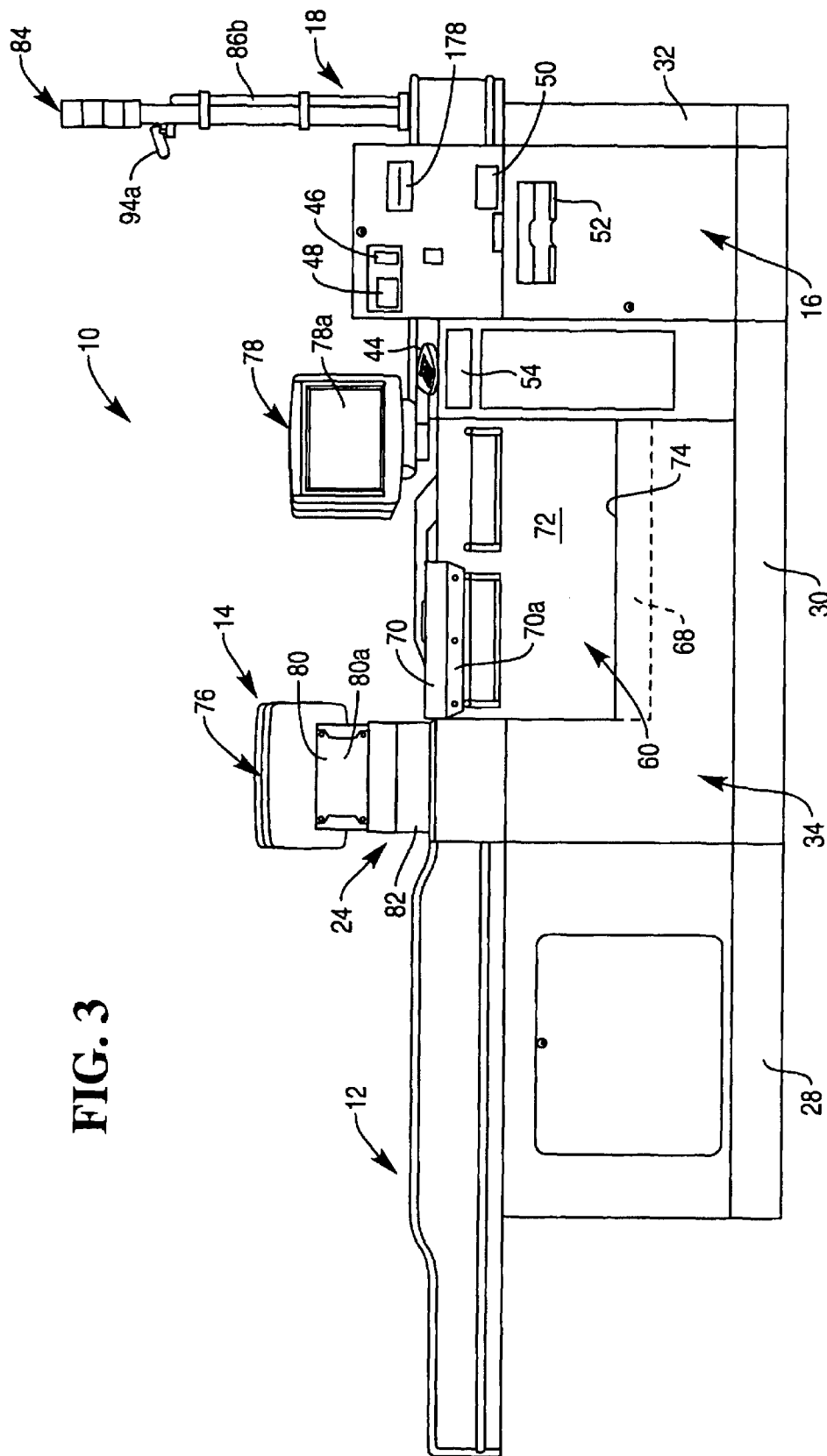
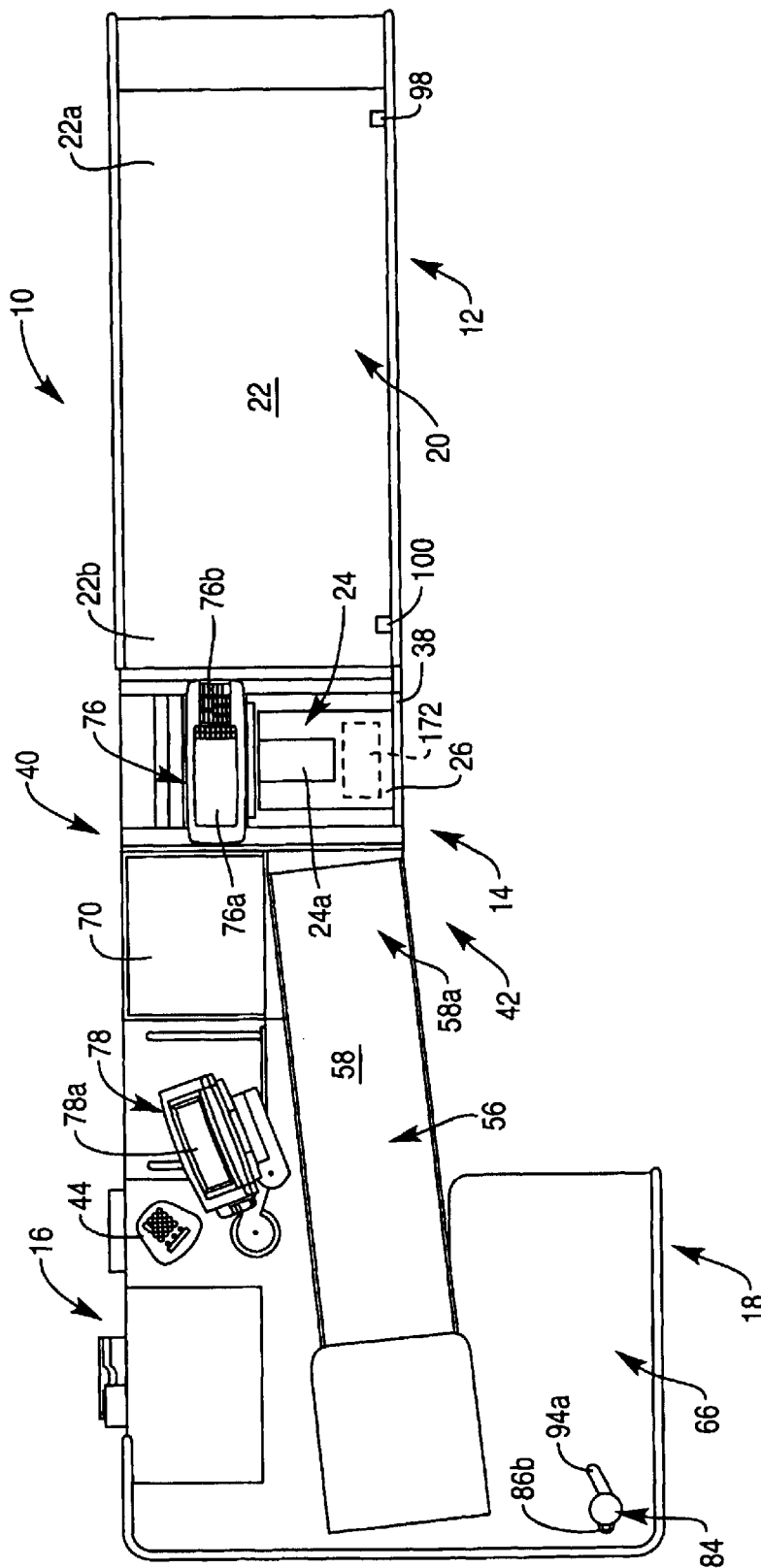

FIG. 4



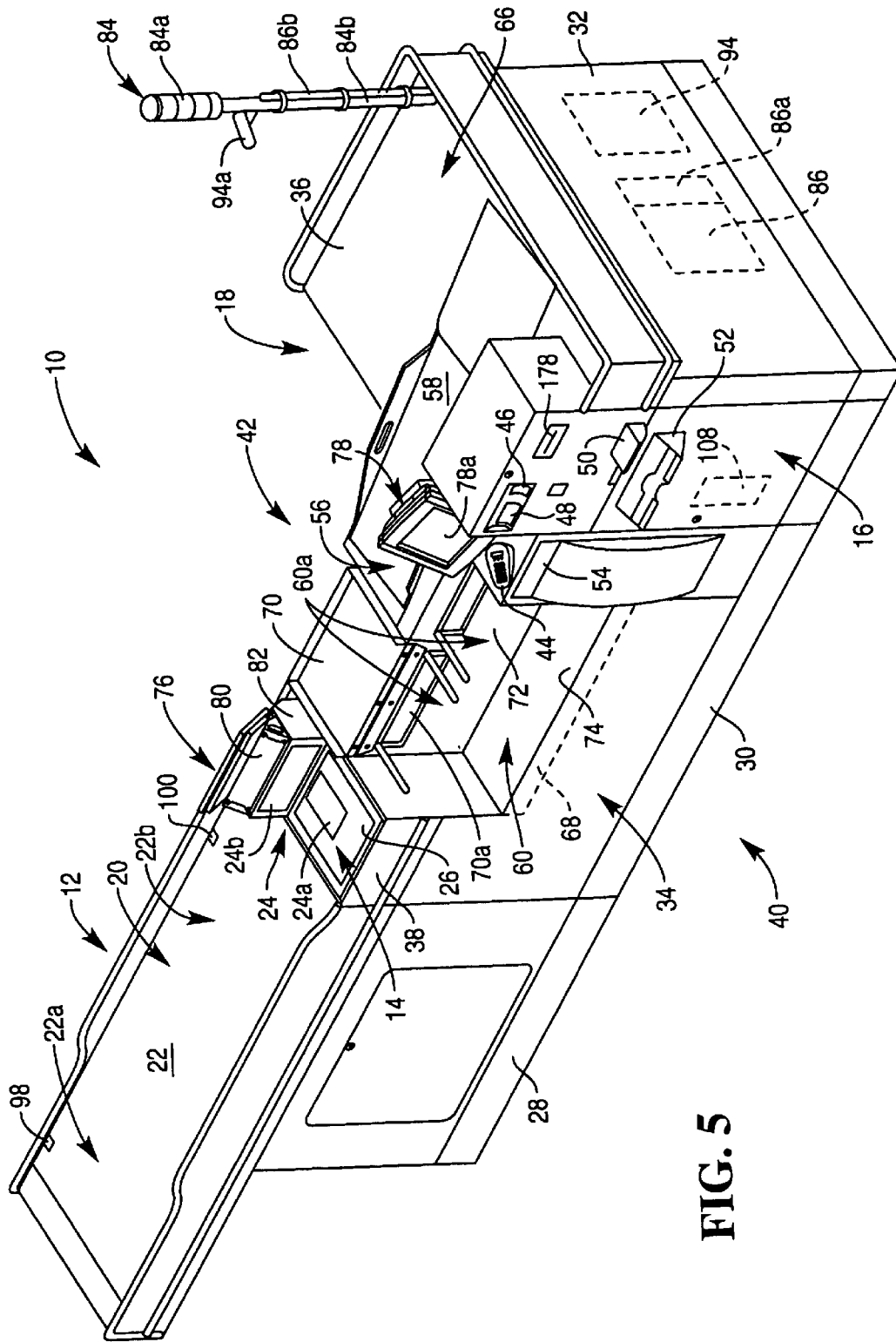
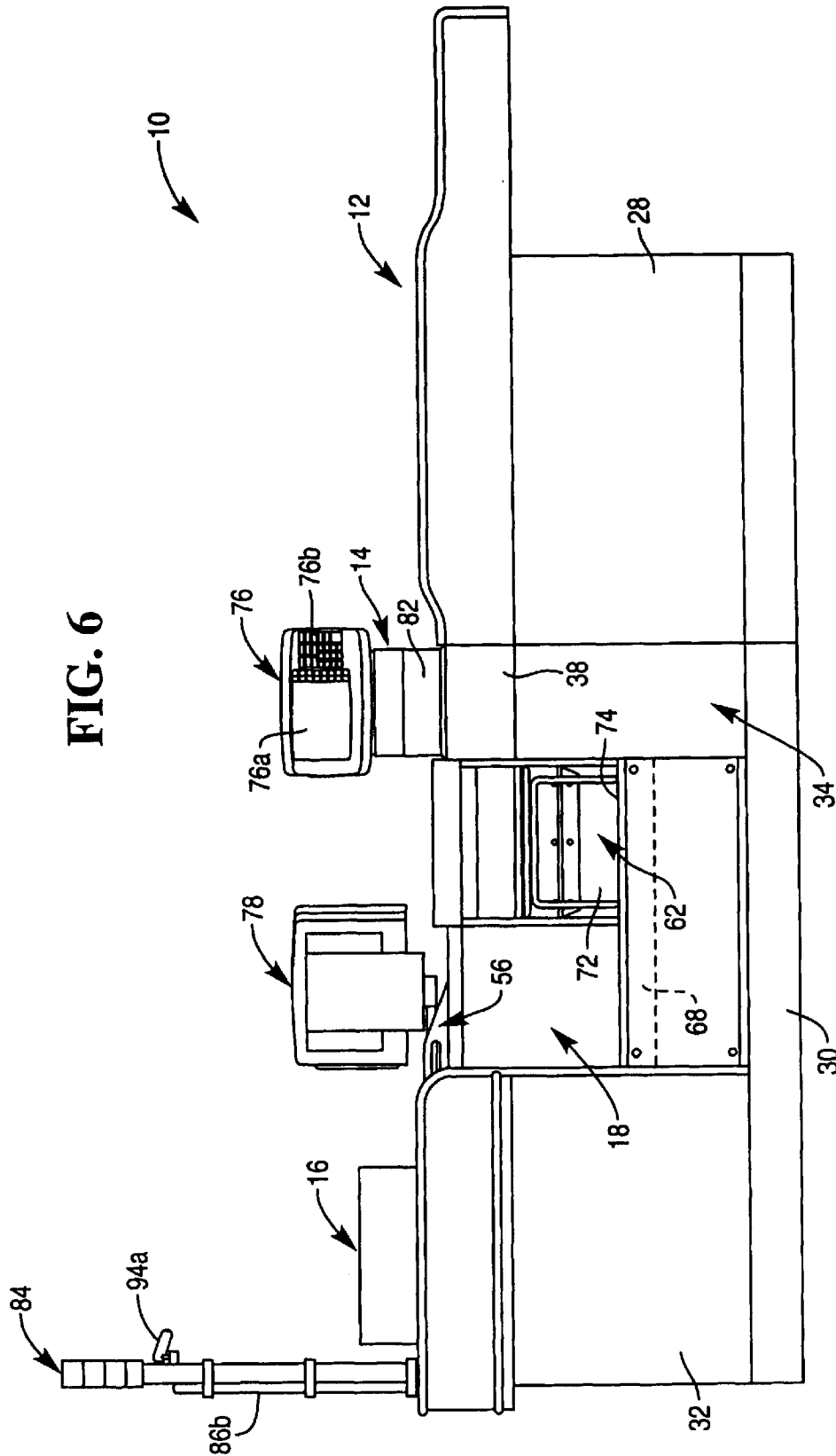

FIG. 5



FIG. 6



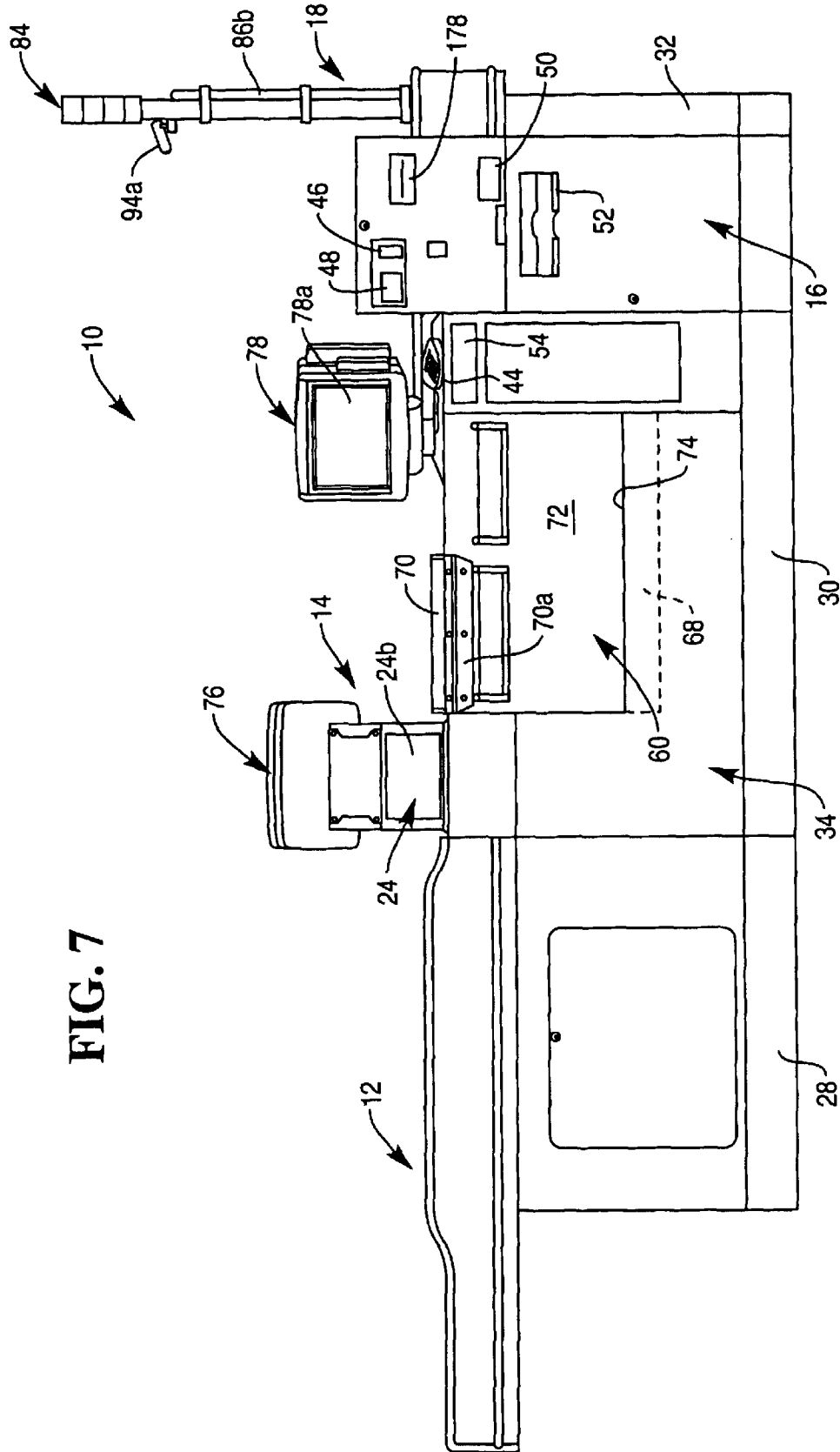
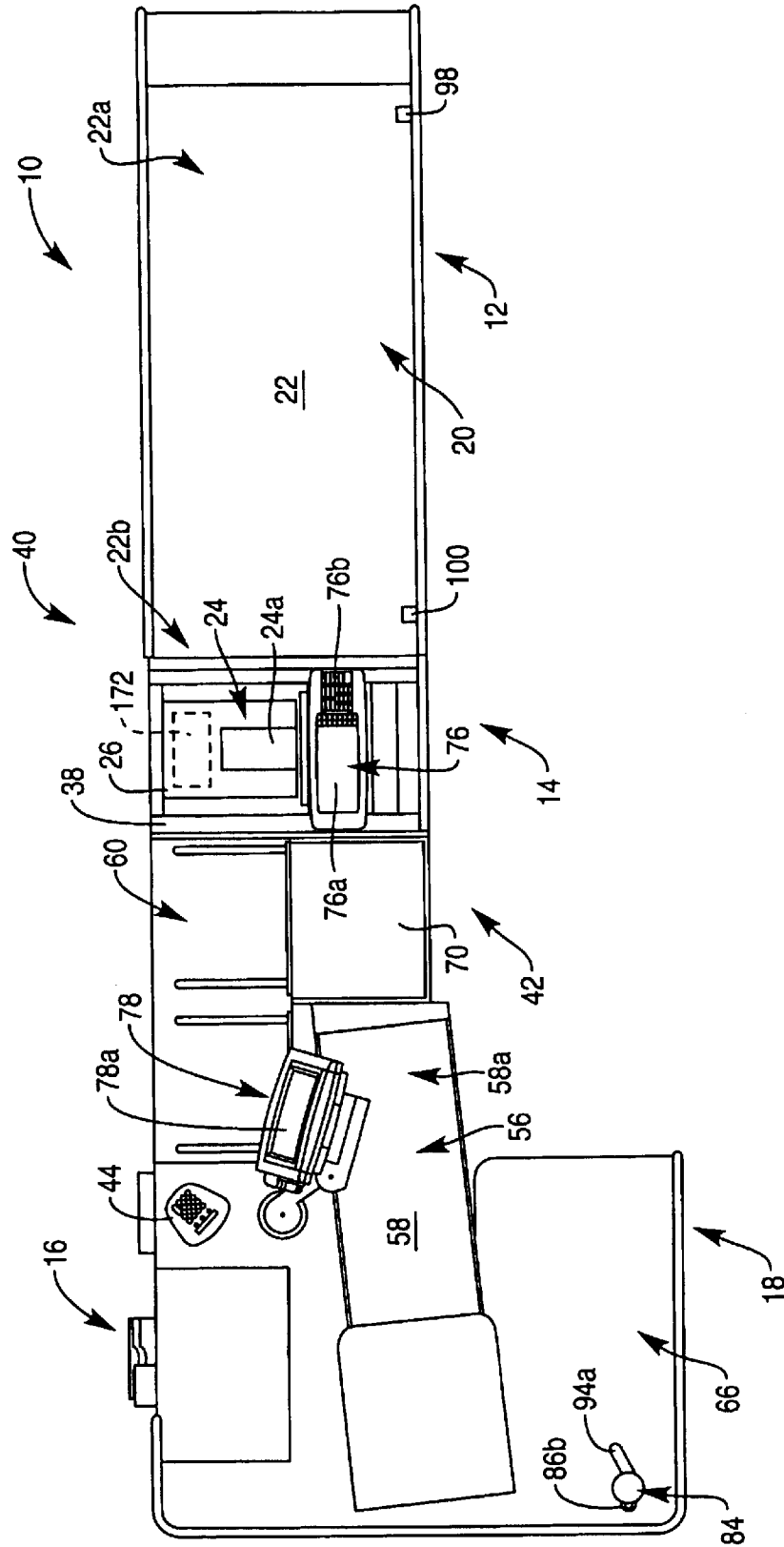
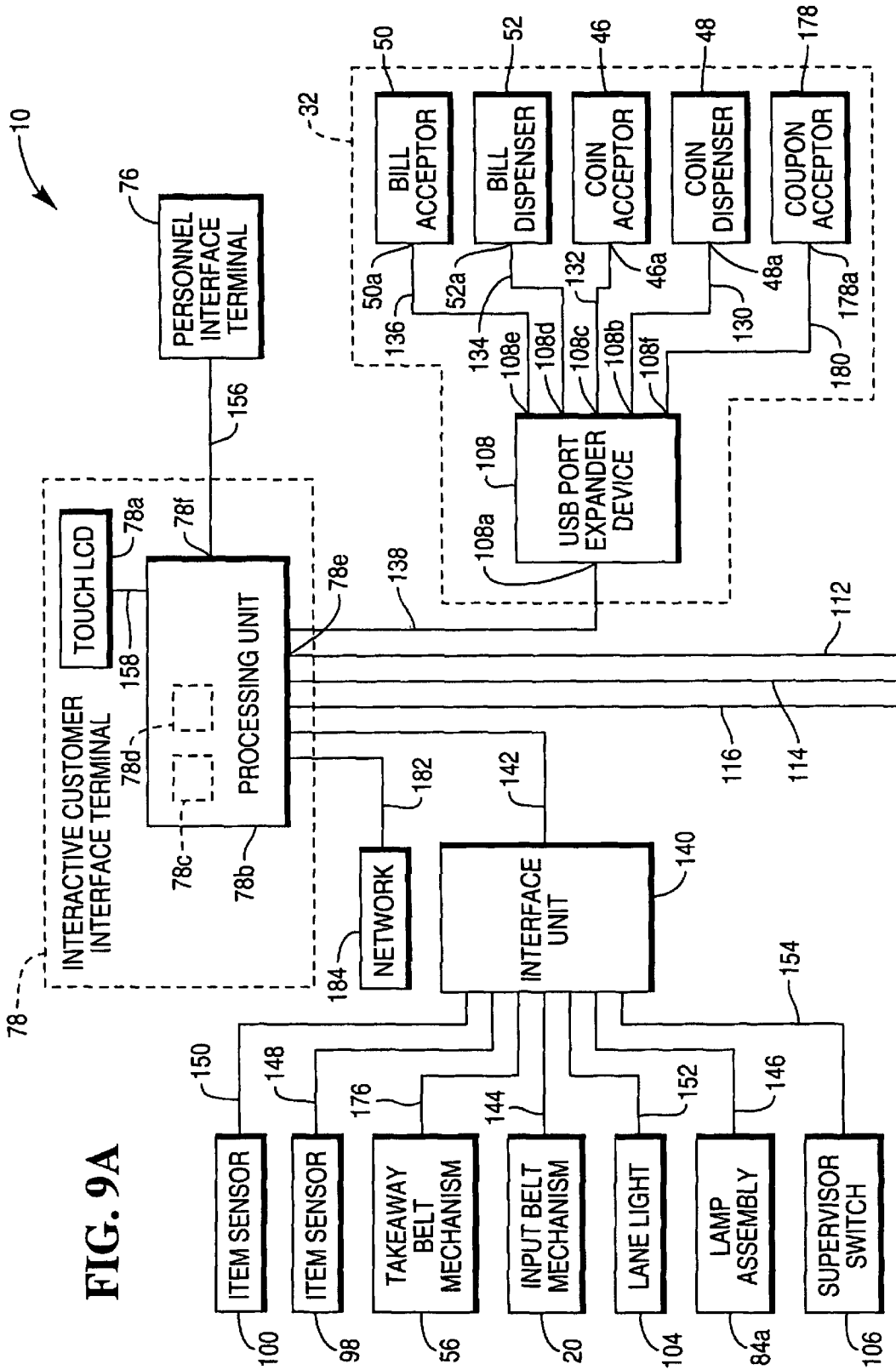

FIG. 7

FIG. 8





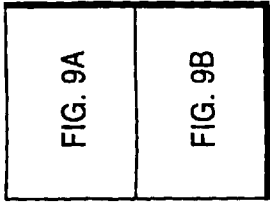

FIG. 9

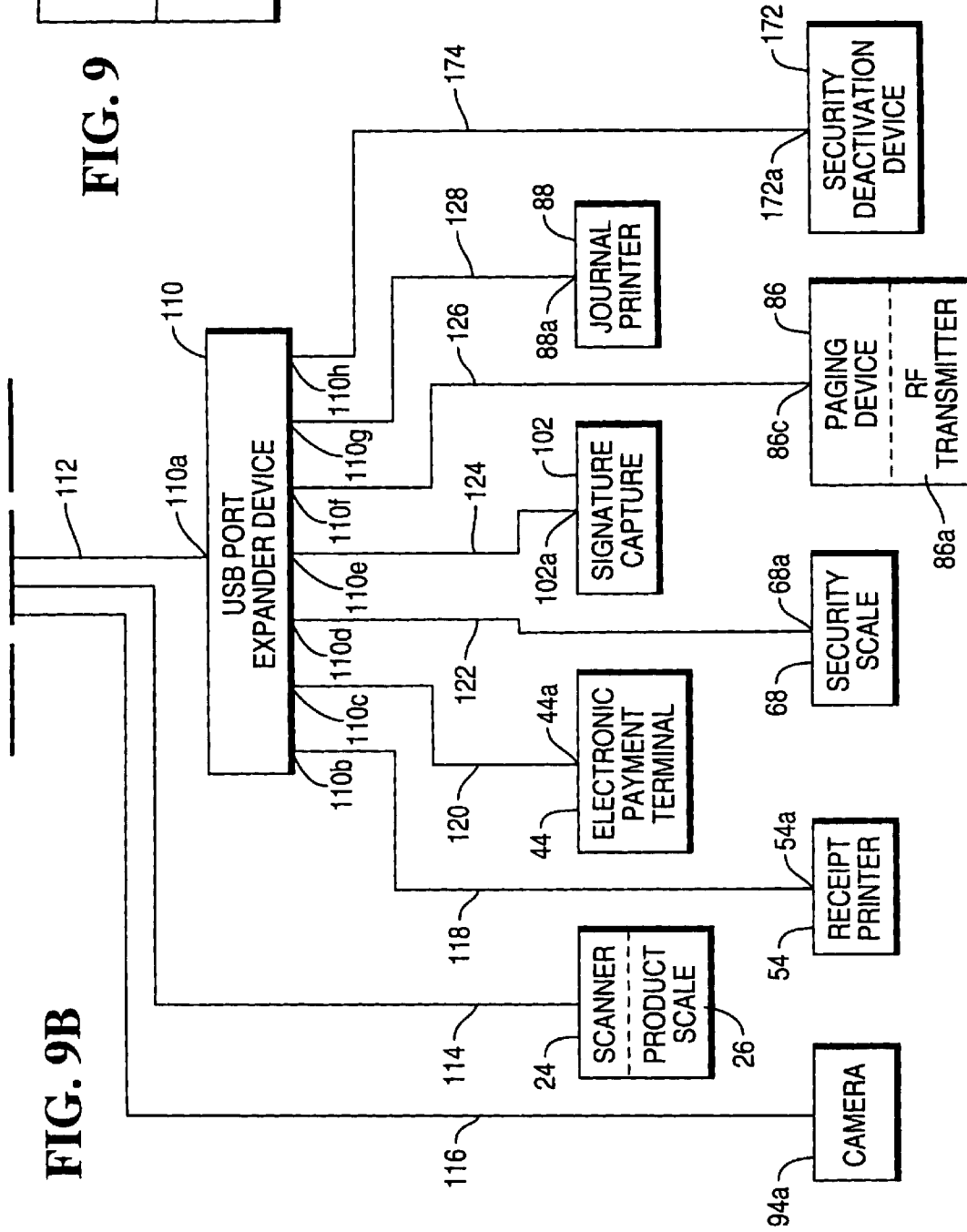
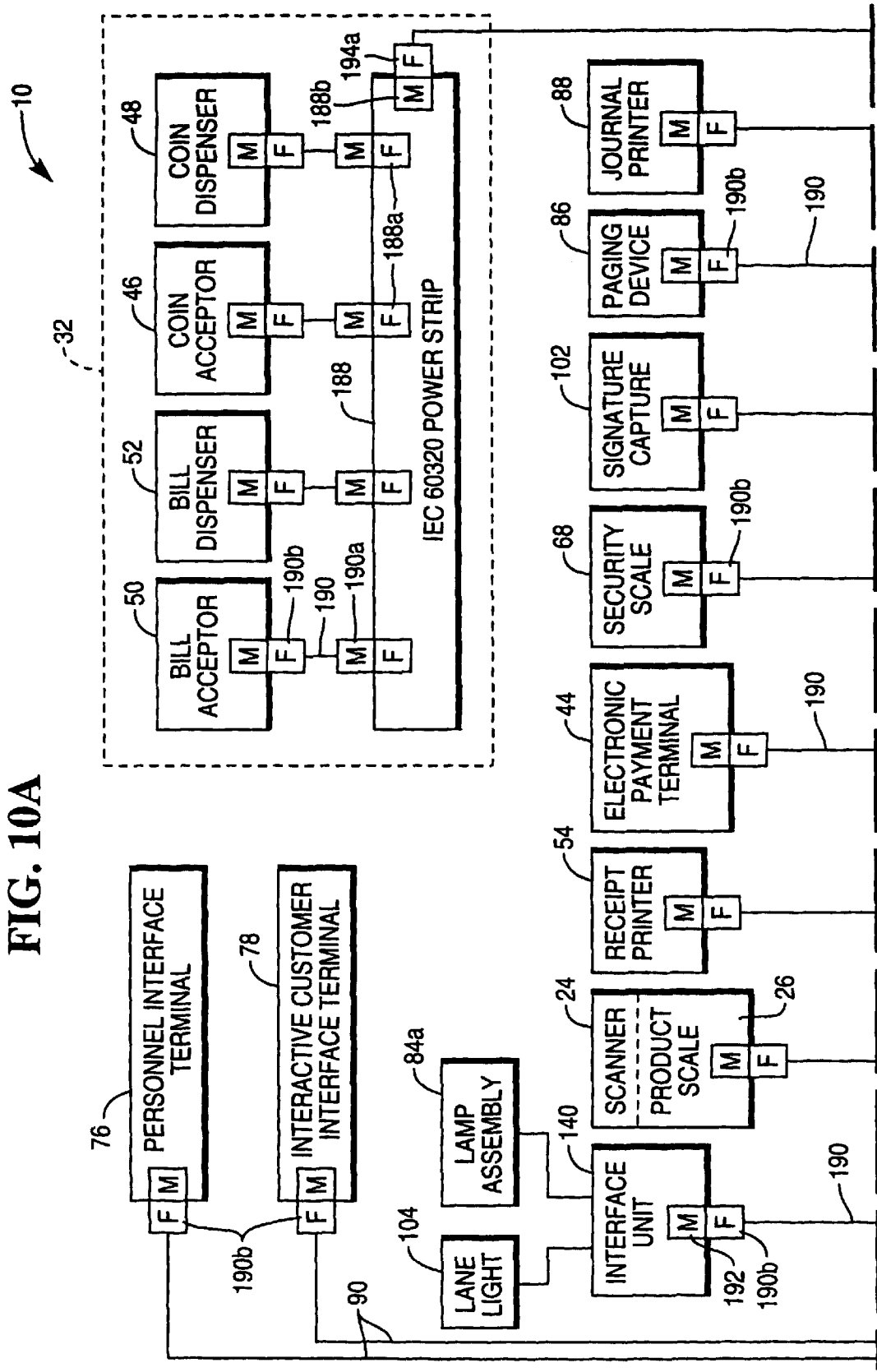

FIG. 9B

FIG. 10A



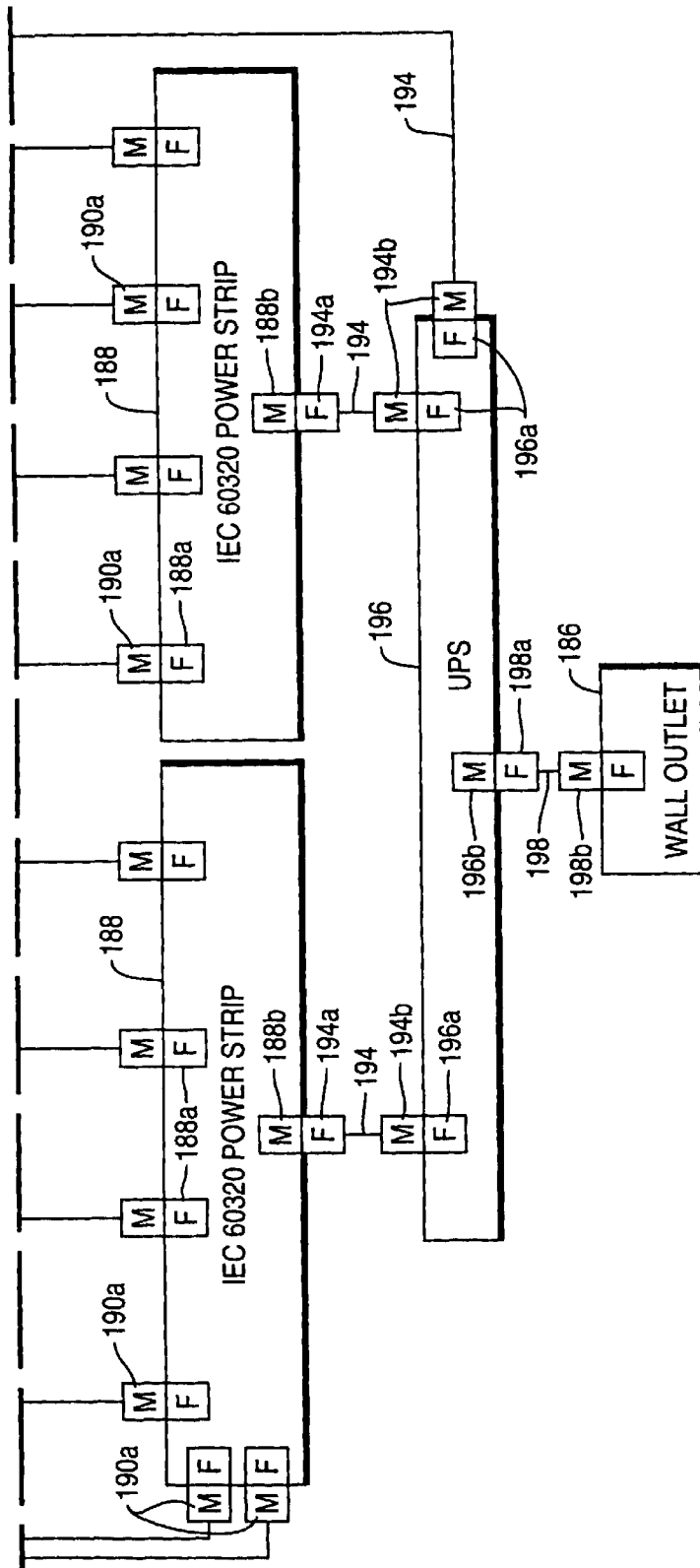

FIG. 10B

FIG. 10

FIG. 10A
FIG. 10B

FIG. 11

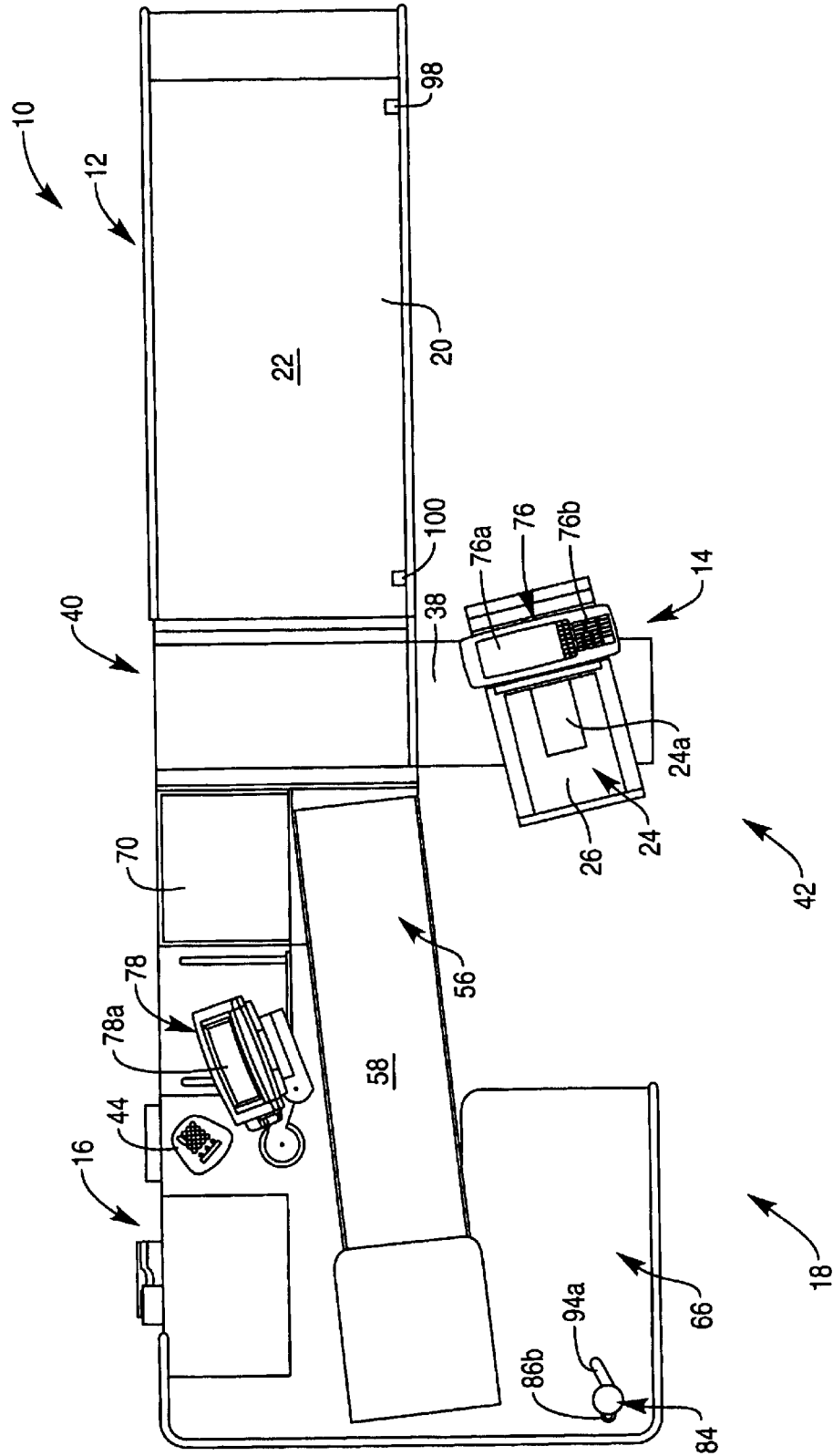



FIG. 12

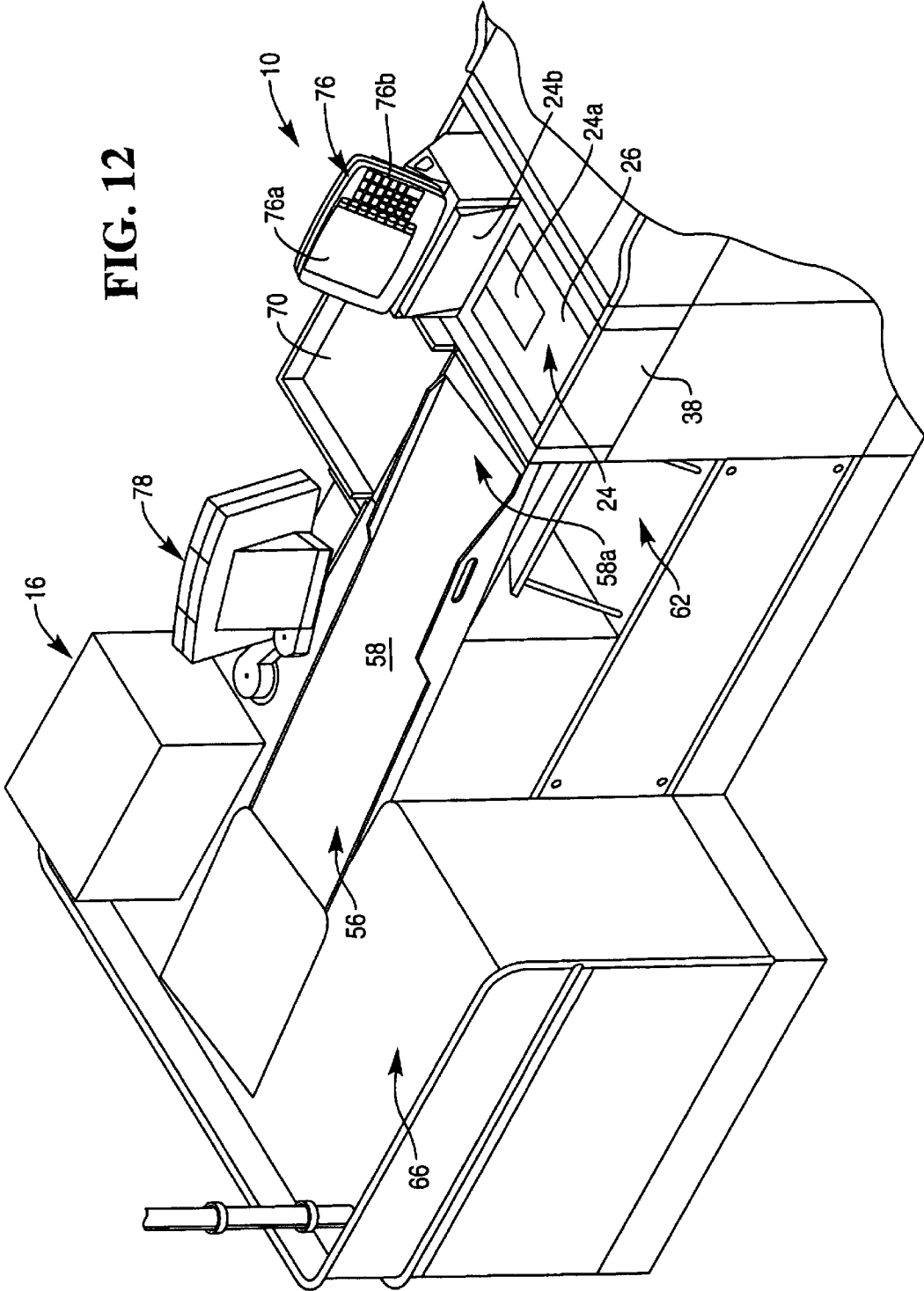
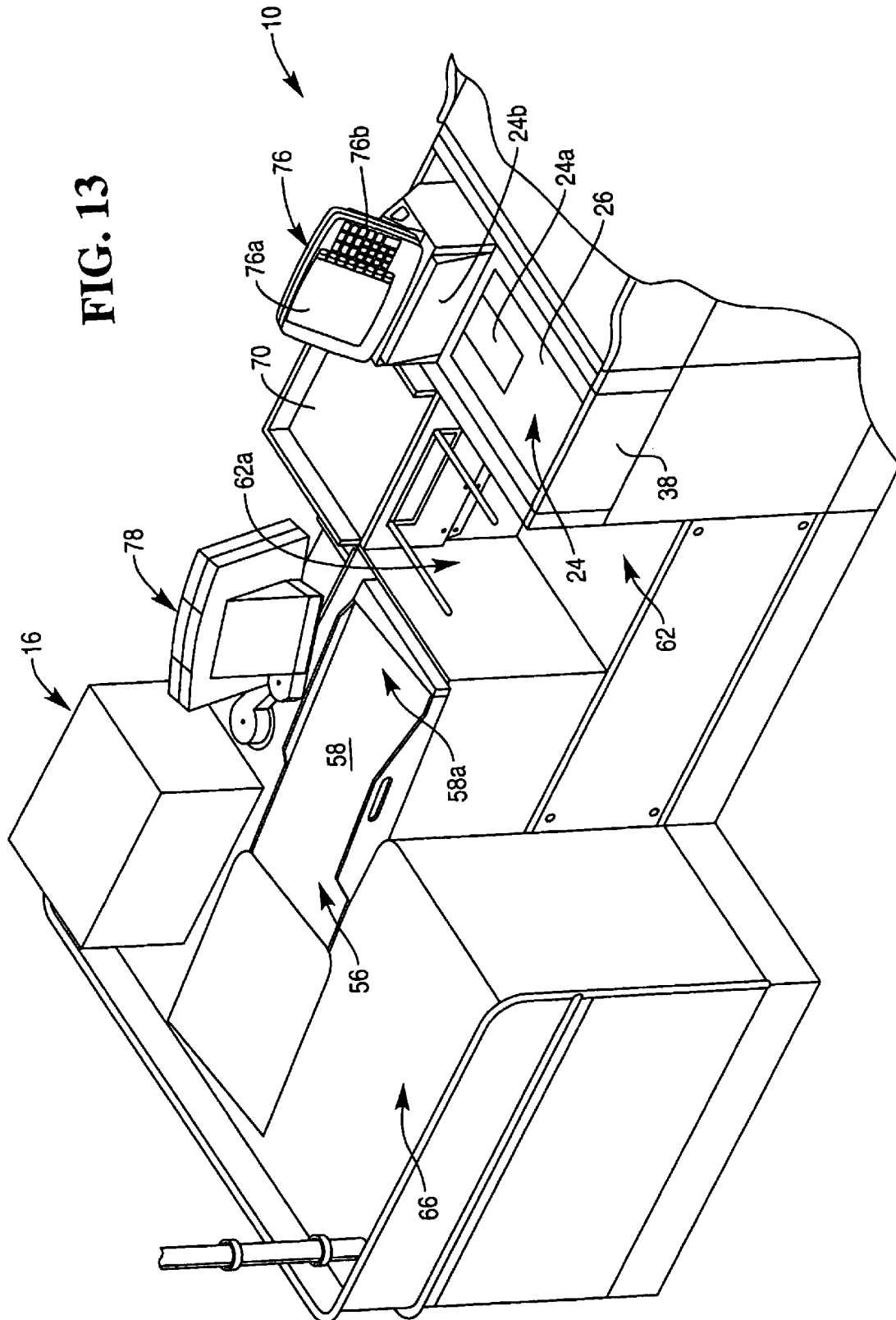

FIG. 13



**FIG. 14**

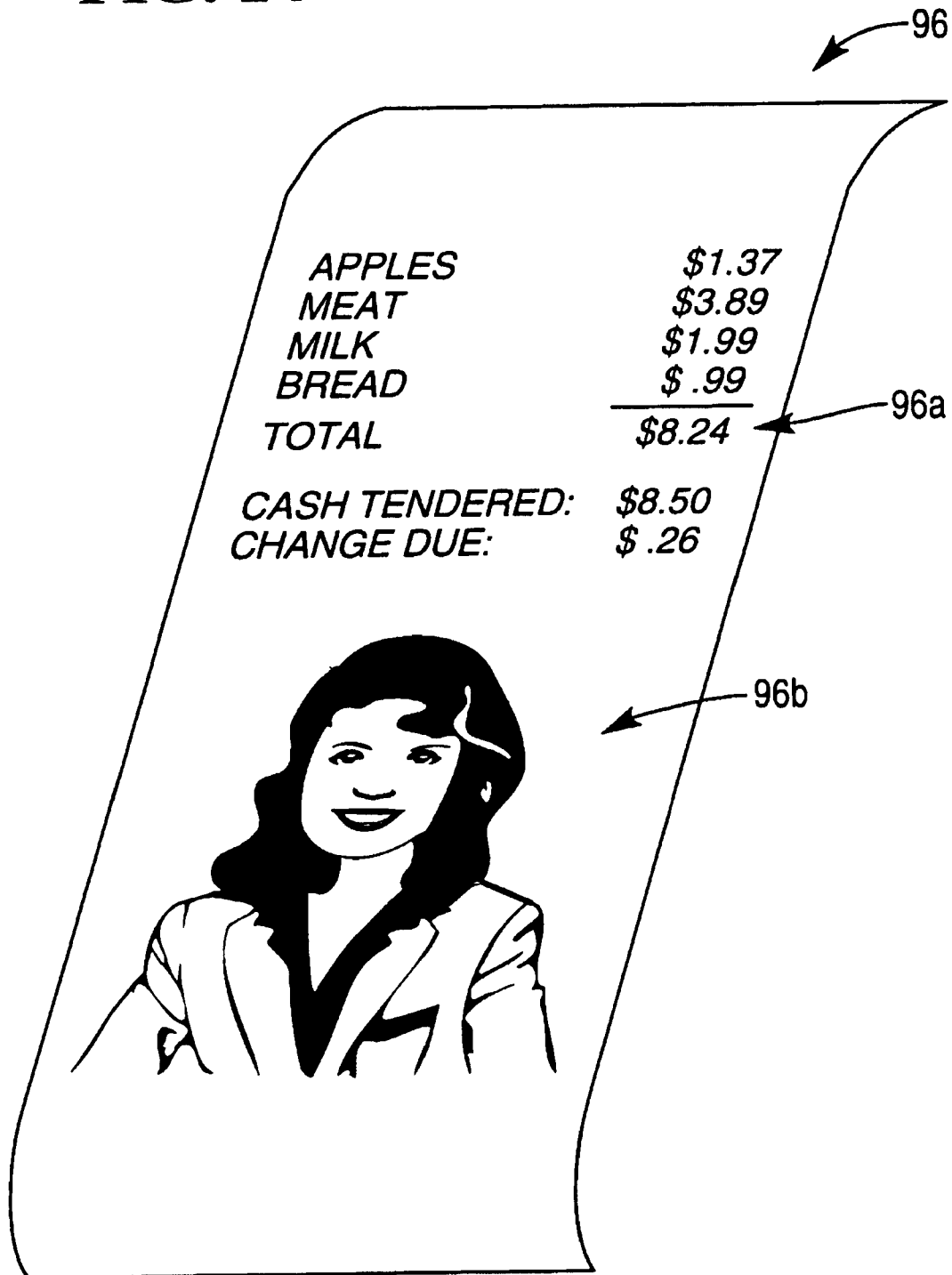
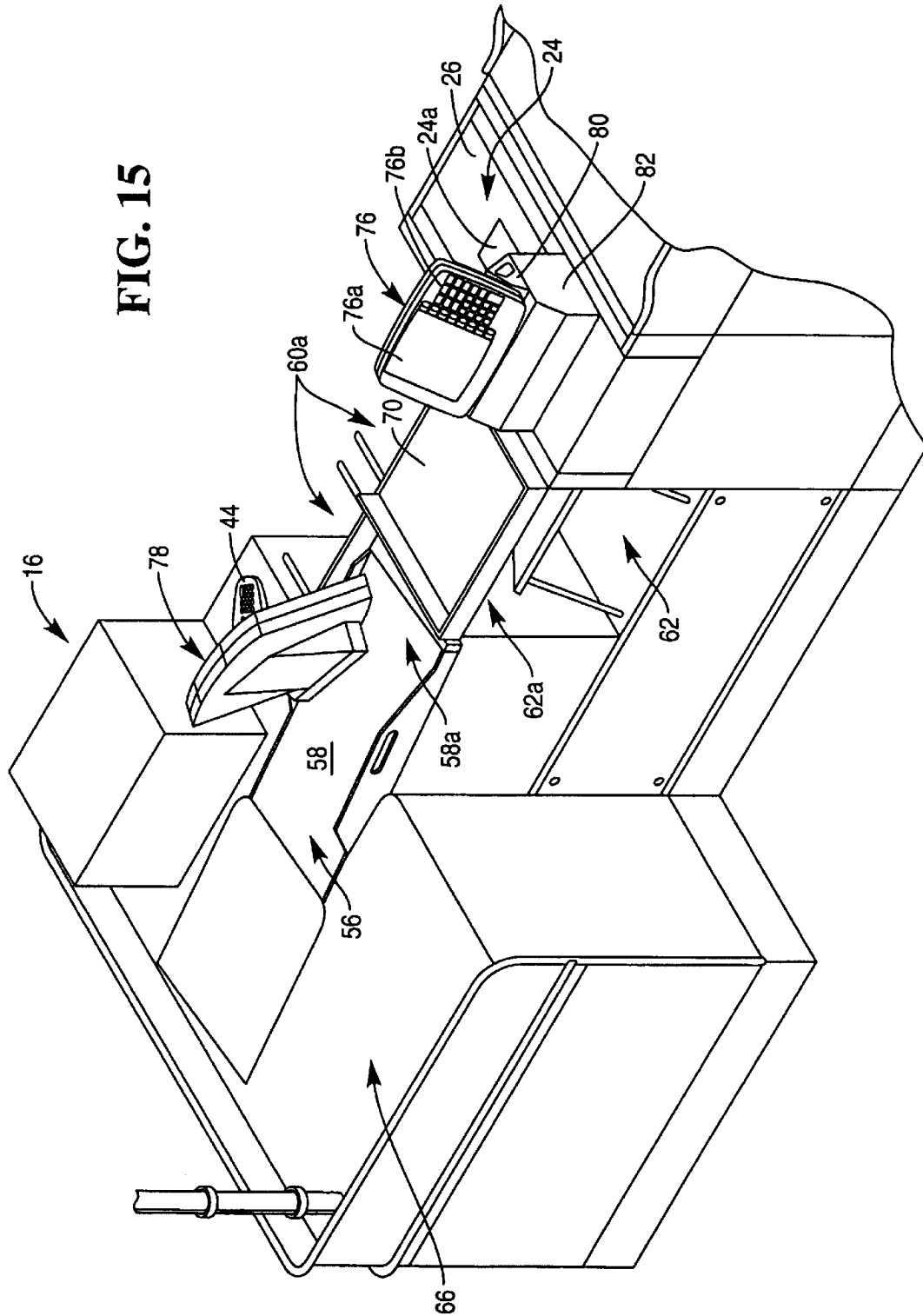

FIG. 15



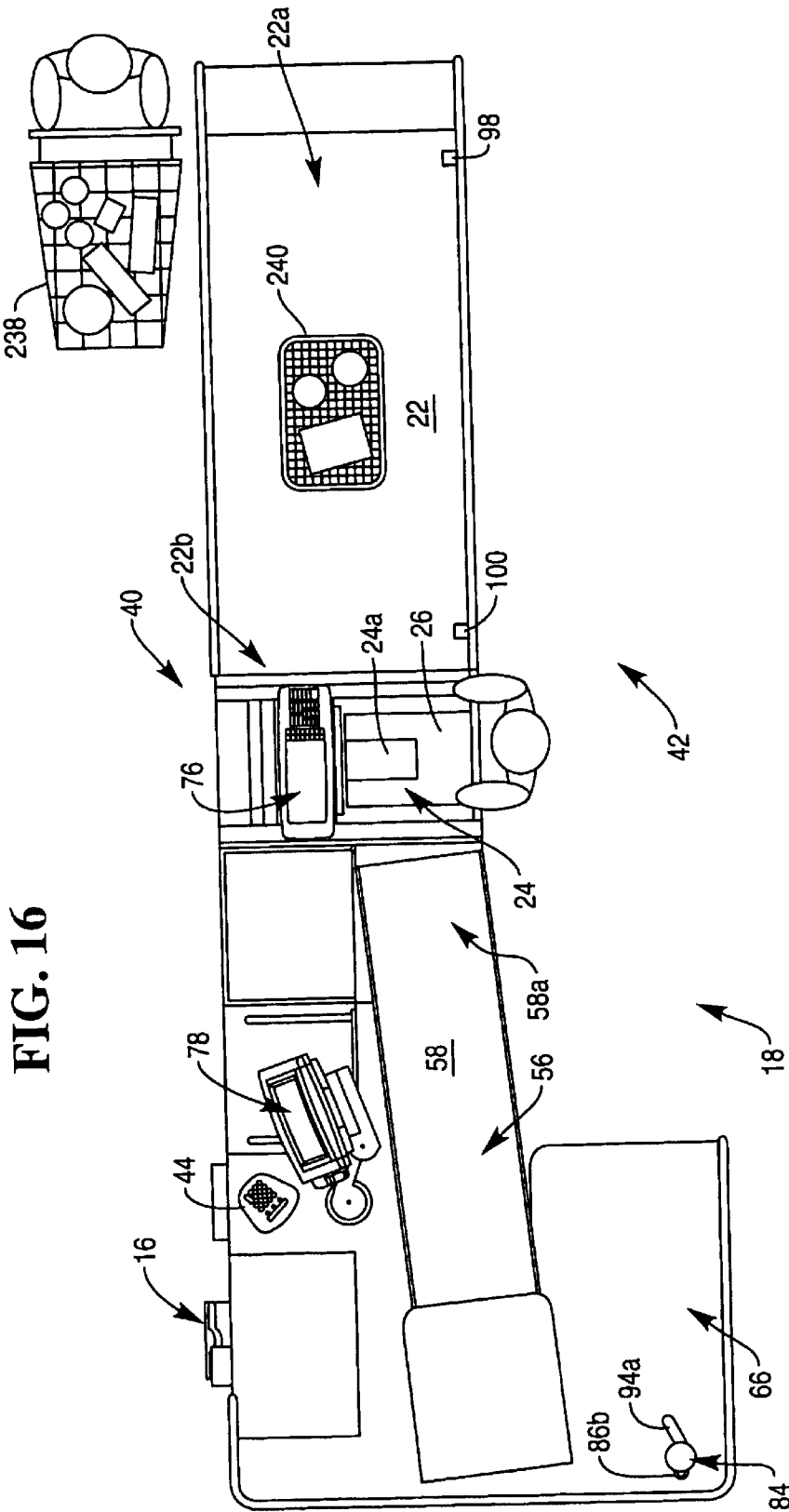
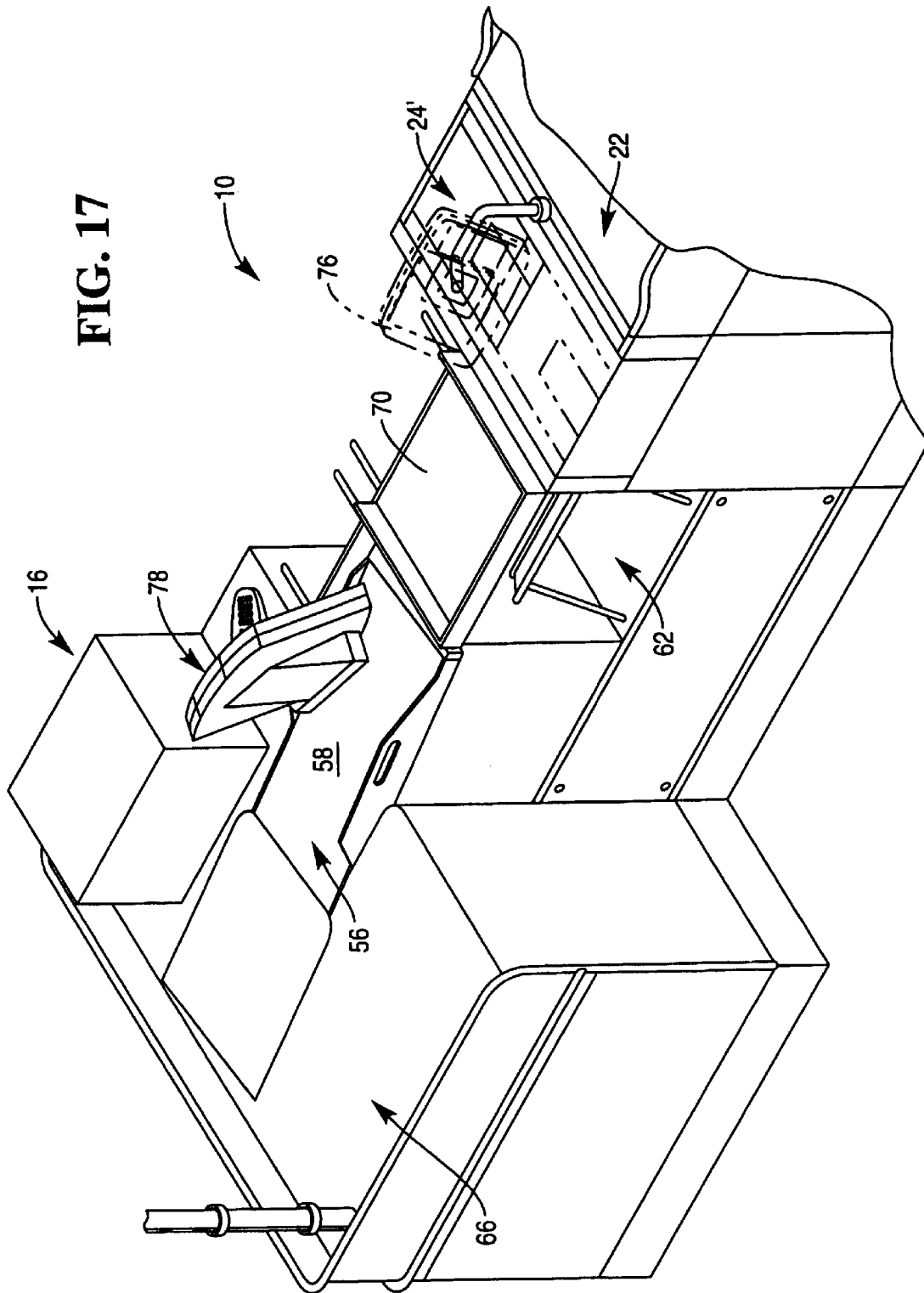
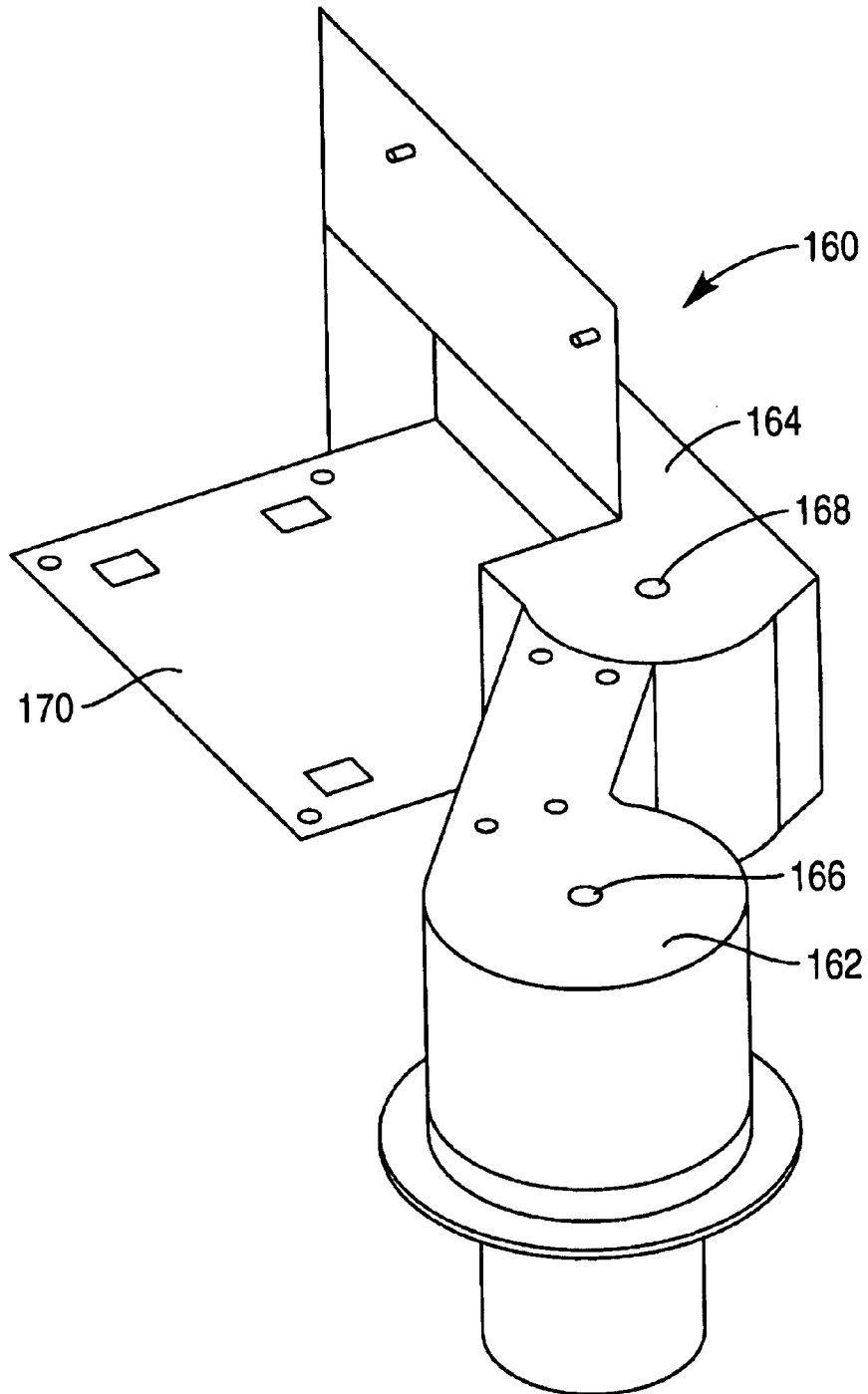

FIG. 16

FIG. 17



**FIG. 18**



**FIG. 19**

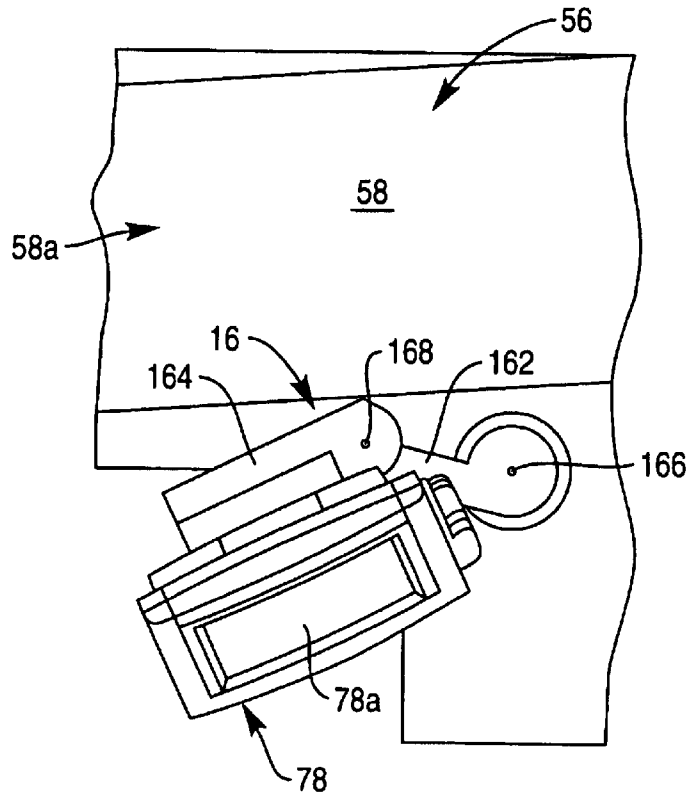

**FIG. 20**

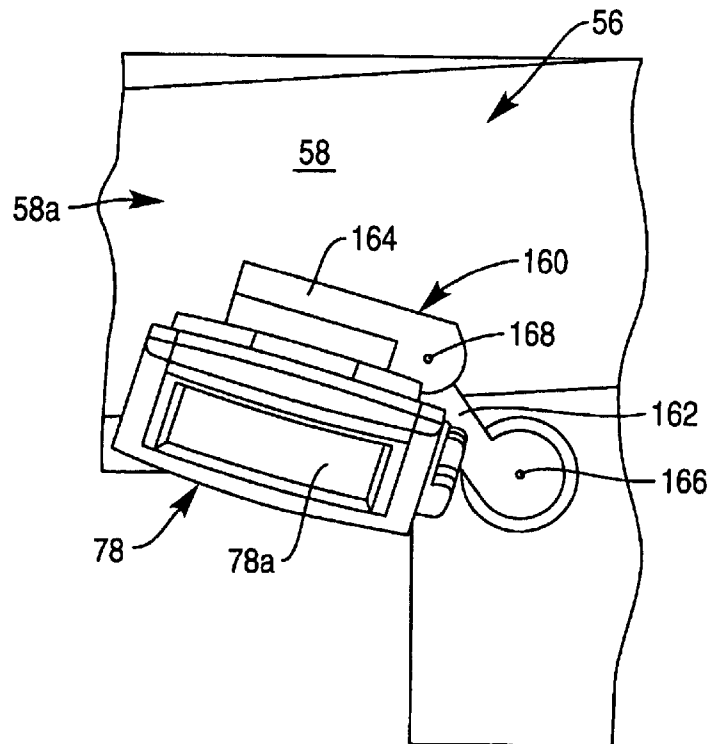



FIG. 21

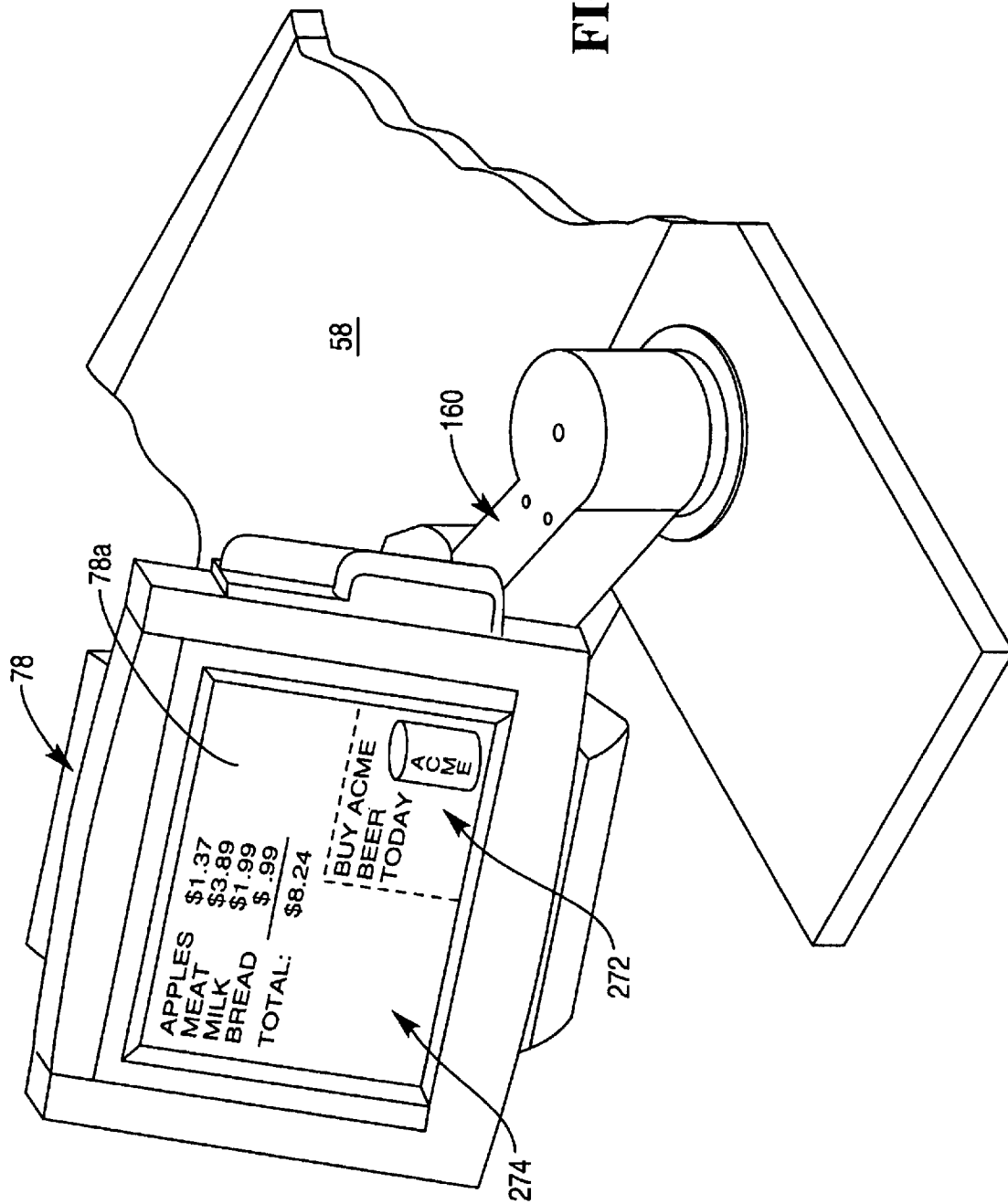

FIG. 22

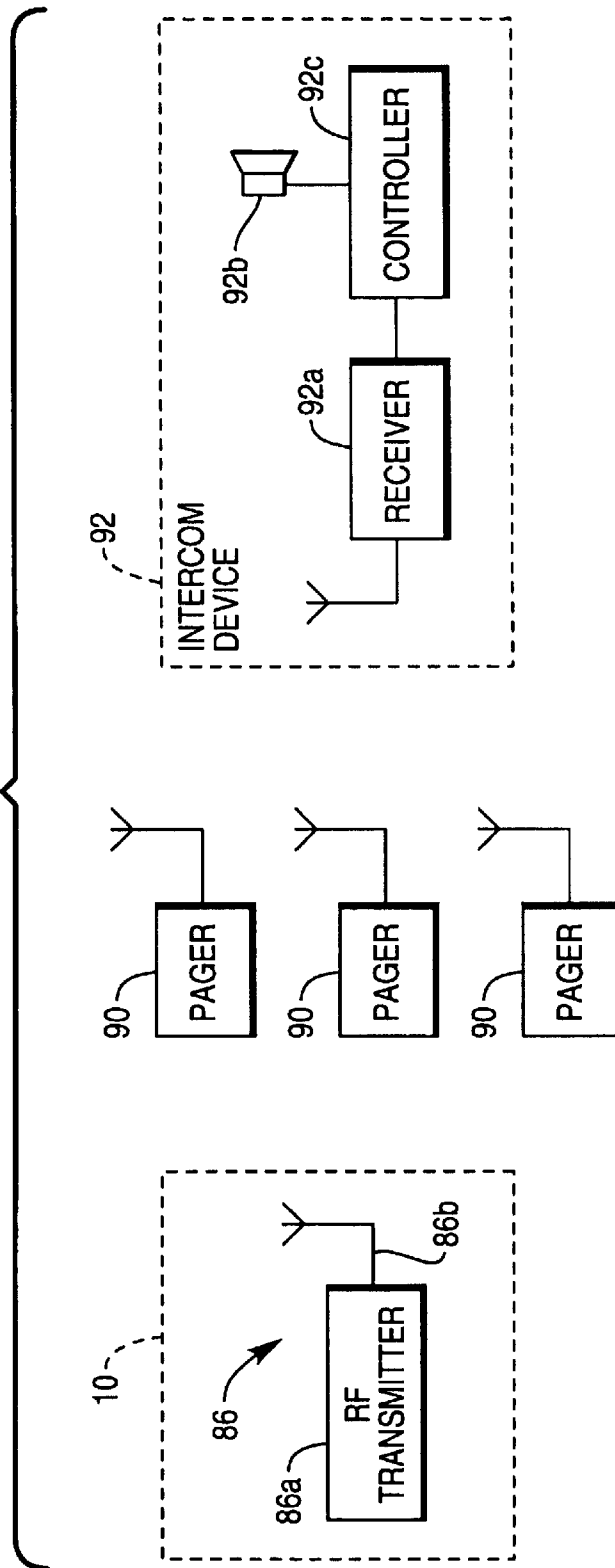
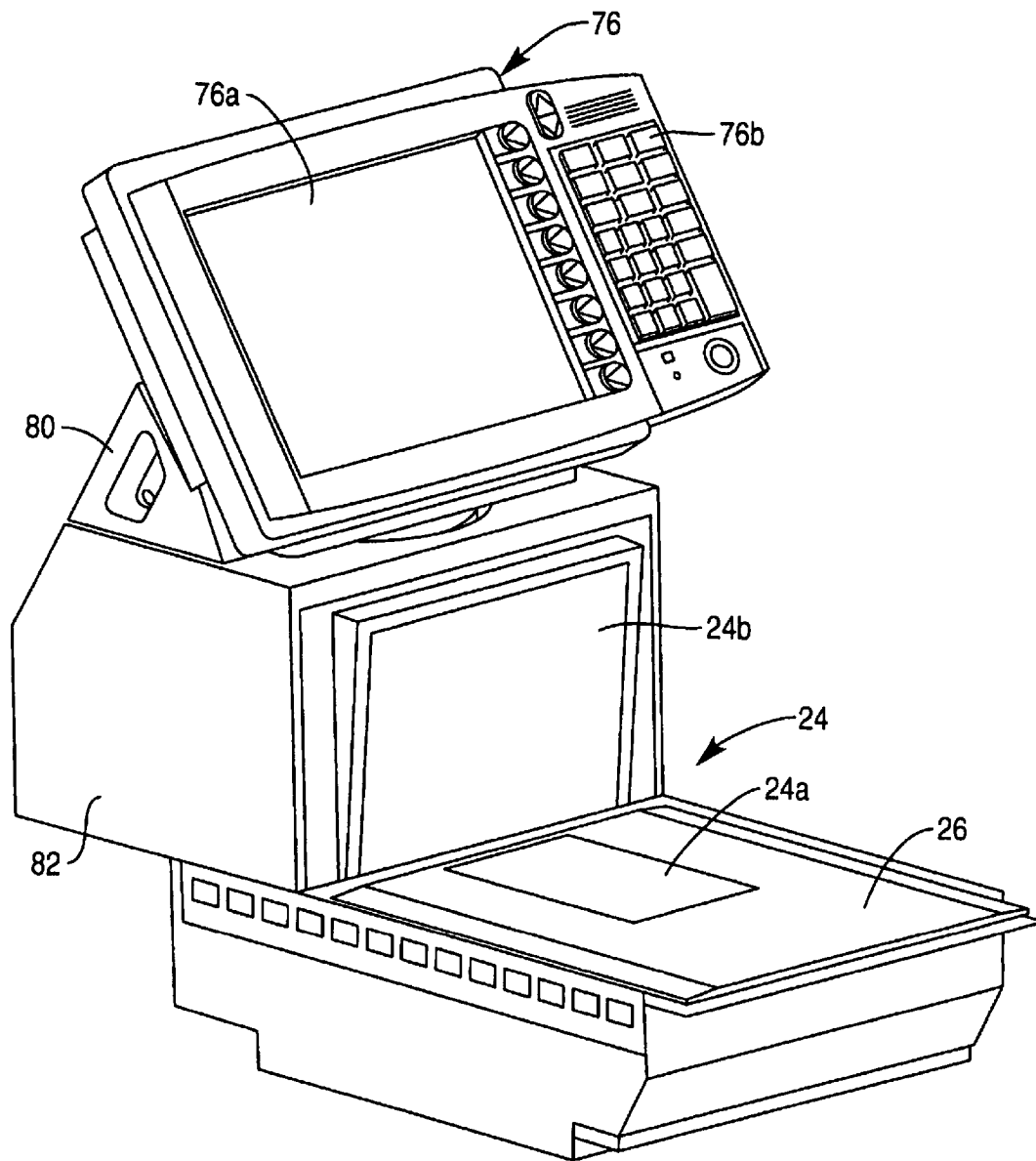

FIG. 23



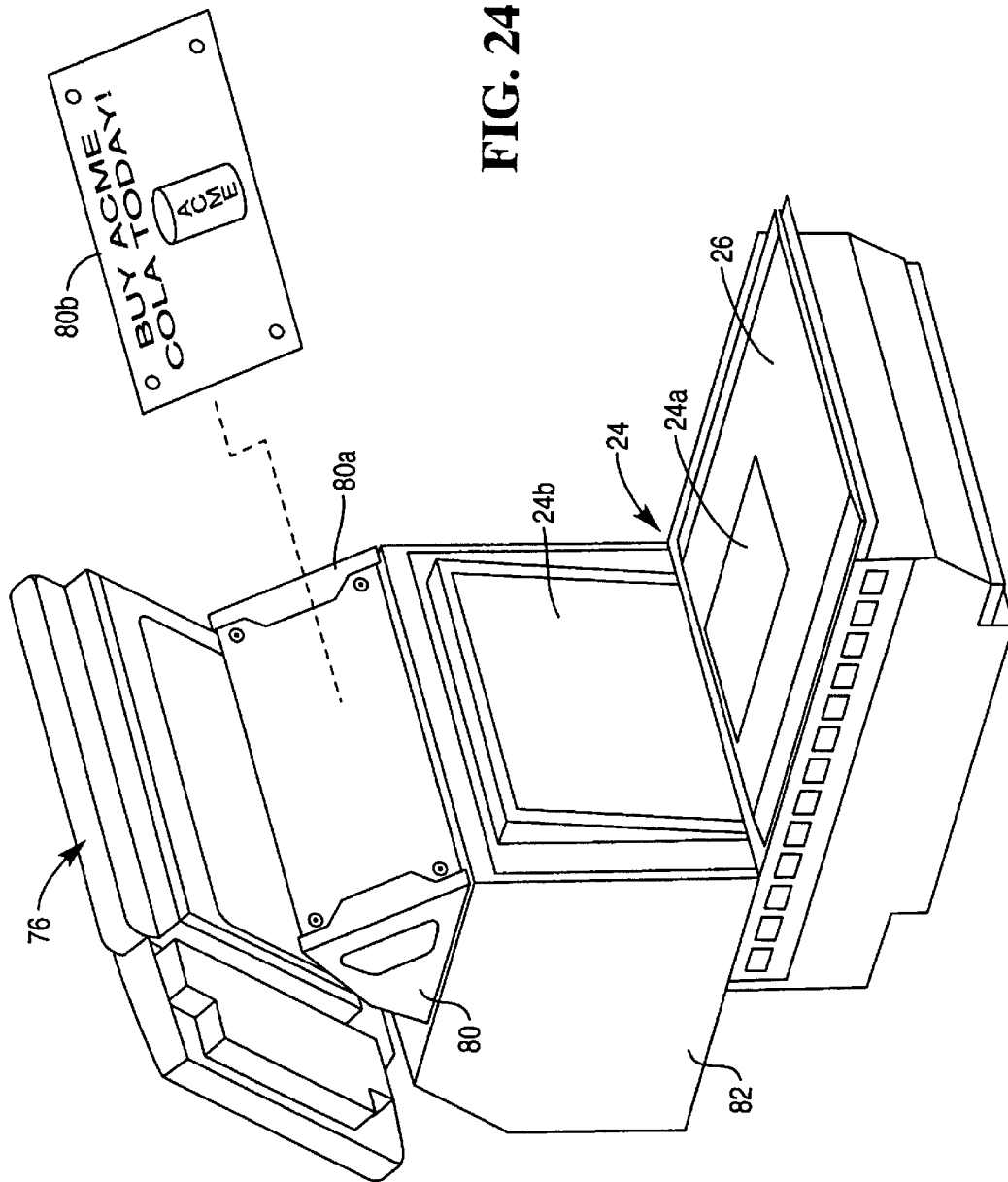

FIG. 25

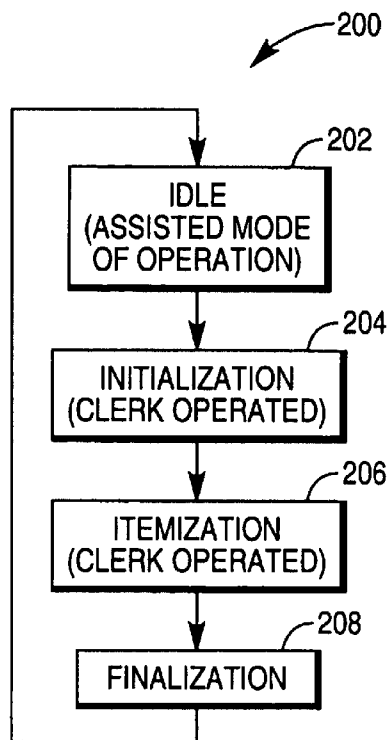
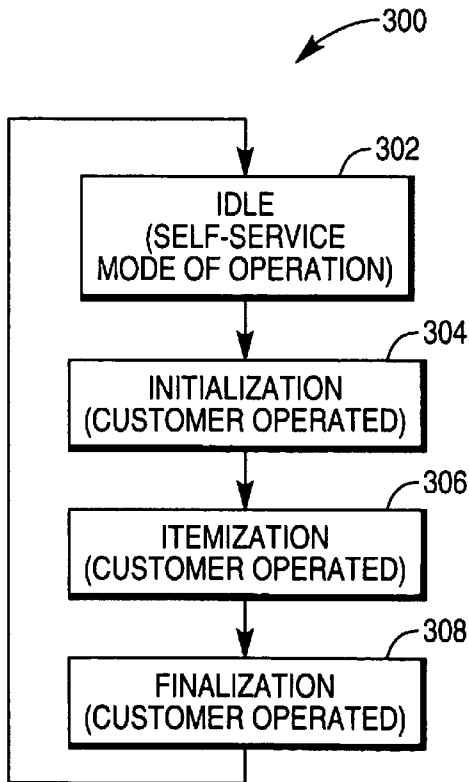

FIG. 28



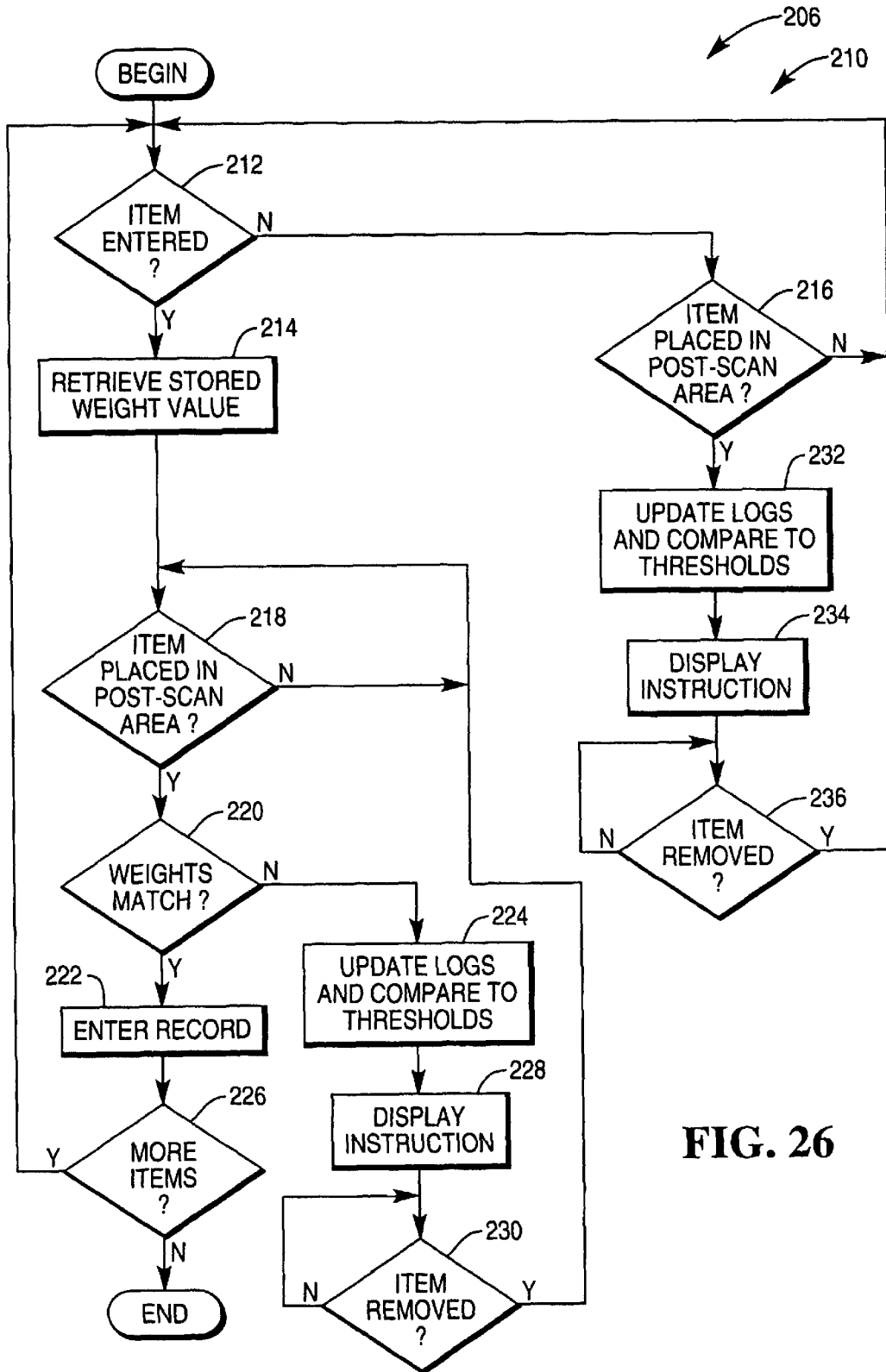
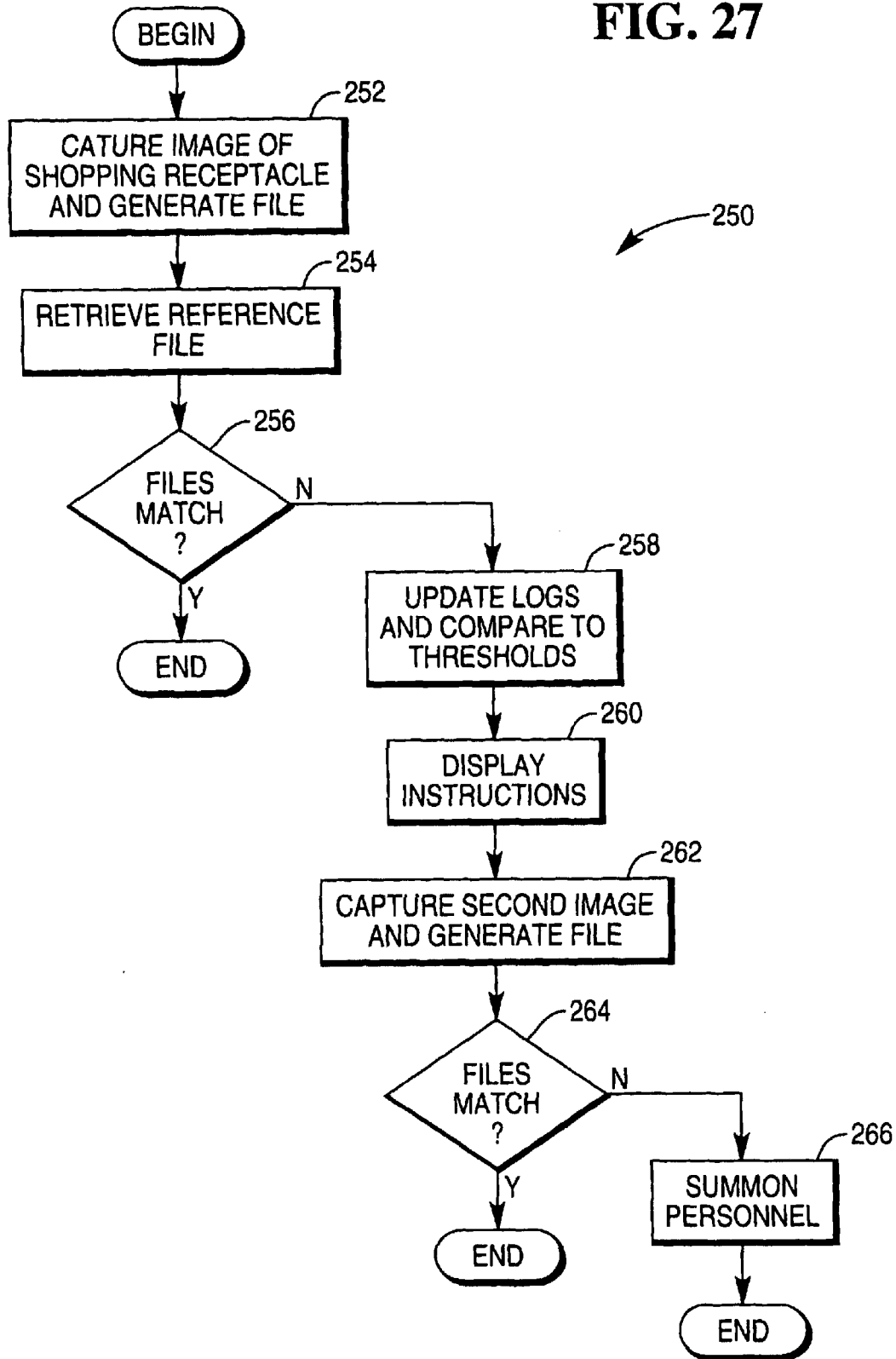

FIG. 26

FIG. 27



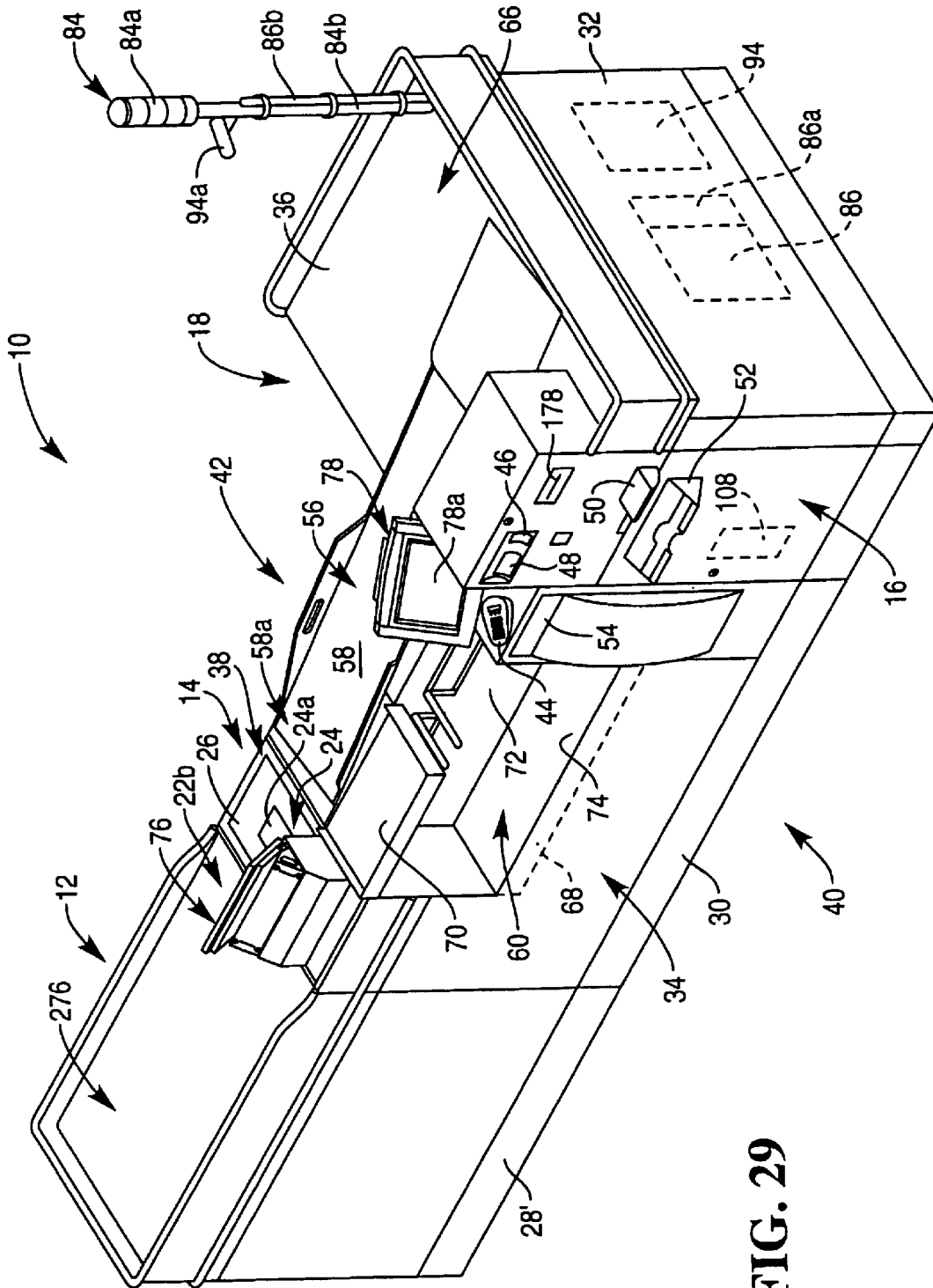

FIG. 29



FIG. 30

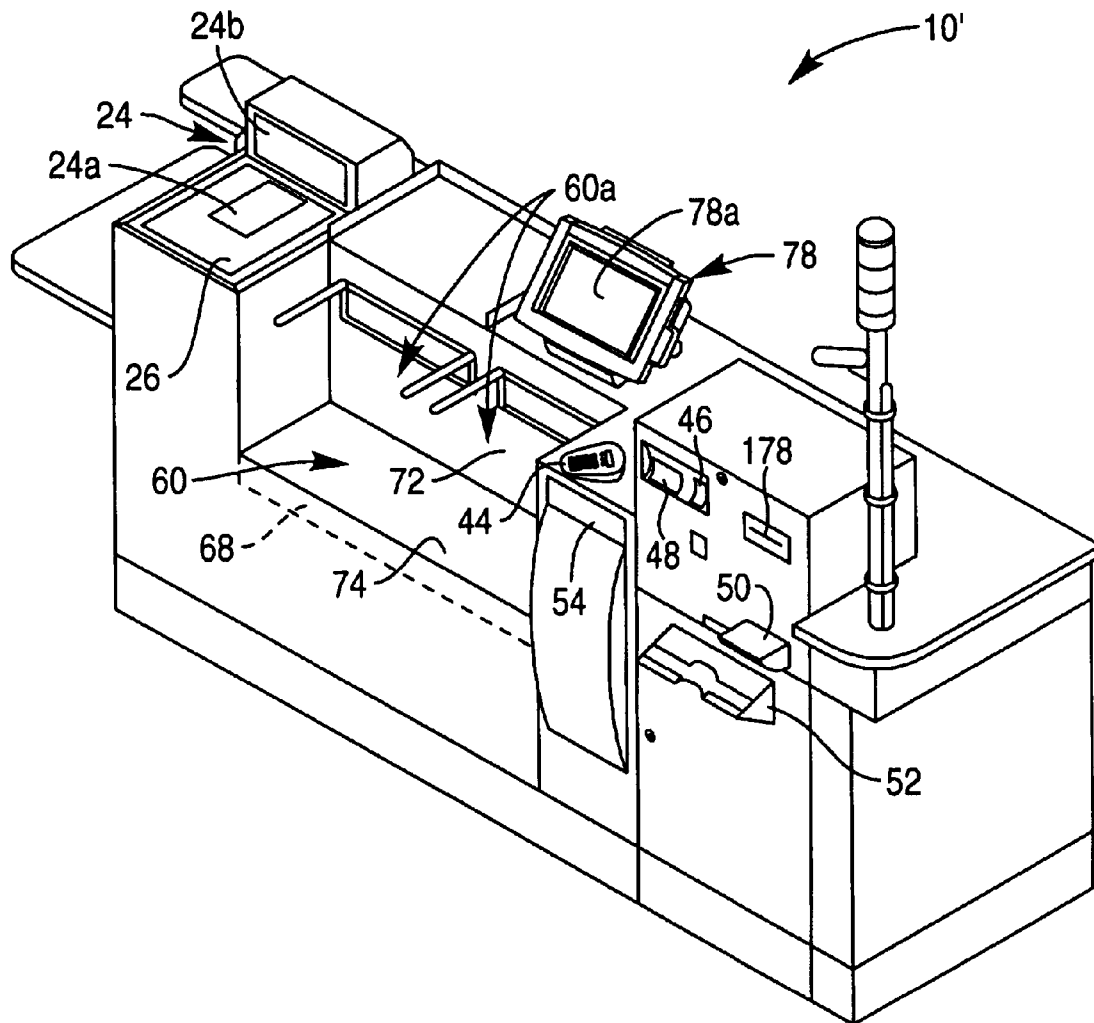
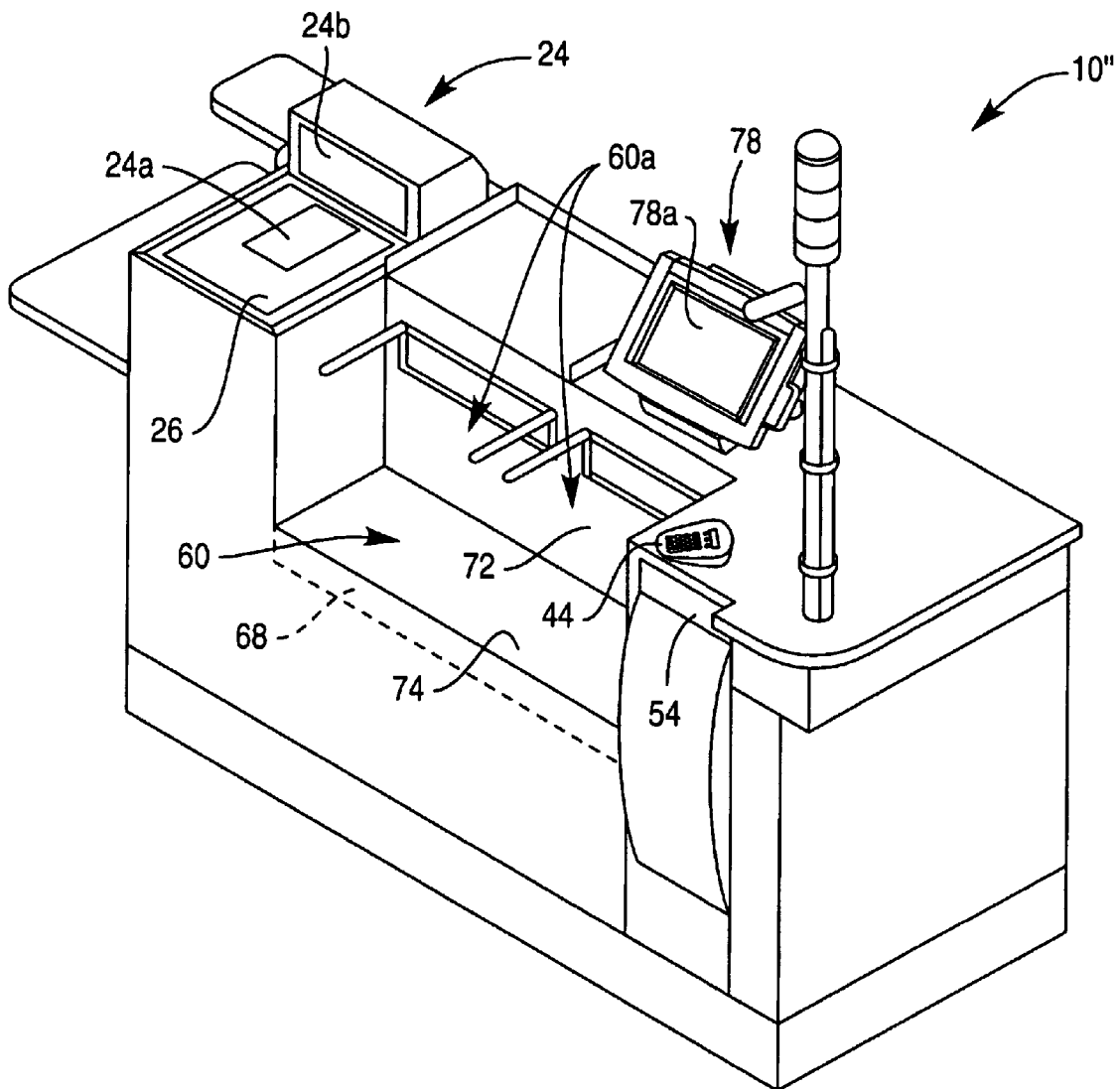

FIG. 31



1

**APPARATUS AND METHOD FOR  
OPERATING A CHECKOUT SYSTEM  
HAVING A DISPLAY MONITOR WHICH  
DISPLAYS BOTH TRANSACTION  
INFORMATION AND CUSTOMER-SPECIFIC  
MESSAGES DURING A CHECKOUT  
TRANSACTION**

**Matter enclosed in heavy brackets [ ] appears in the original patent but forms no part of this reissue specification; matter printed in italics indicates the additions made by reissue.**

CROSS REFERENCE

Cross reference is made to copending U.S. patent applica-  
tions Ser. No. 09/432,638, entitled "Apparatus and Method  
for Operating a Checkout System Having a Security Scale  
for Providing Security During an Assisted Checkout Trans-  
action" by Wilfried E. Y. Dejaeger; Ser. No. 09/432,641,  
entitled "Apparatus and Method for Operating a Checkout  
System Having a Scanner Which is Rotatable Between an  
Assisted Scanner Position and a Self-Service Scanner Posi-  
tion" by Wilfried E. Y. Dejaeger, Mark S. Hoffman, Terry M.  
Glogovsky, and Alfred J. Hutcheon; Ser. No. 09/432,636,  
entitled "Apparatus and Method for Operating Convertible  
Checkout System Which Has a Customer Side and a Person-  
nel Side" by Wilfried E. Y. Dejaeger, Alfred J. Hutcheon,  
John C. Addy, and James Morrison; Ser. No. 09/432,636,  
entitled "Apparatus and Method for Operating a Checkout  
System Having a Movable Takeaway Belt Mechanism and  
Associated System Construction" by Charles K. Wike, Jr.,  
Kurt J. Lippert, and Paul F. Nugent, Jr.; Ser. No. 09/432,635,  
entitled "Apparatus and Method for Operating a Checkout  
System Having an Item Set-Aside Shelf Which is Movable  
Between a Number of Shelf Positions" by Paul F. Nugent,  
Jr.; Ser. No. 09/432,634, entitled "Apparatus and Method for  
Operating a Checkout System Having a Number of Port  
Expander Devices Associated Therewith" by Robert T. Snyder;  
Ser. No. 09/432,637, entitled "Apparatus and Method  
for Operating a Checkout System Having a Power Distribu-  
tion Architecture Which Conforms to an International Stan-  
dard" by Robert T. Snyder; Ser. No. 09/432,626, entitled  
"Apparatus and Method for Operating a Checkout System  
Having an Electronic Security Deactivation Device Associ-  
ated Therewith" by Robert T. Snyder and Kurt J. Lippert;  
Ser. No. 09/432,157, entitled "Apparatus and Method for  
Operating a Checkout System Which Has a Number of Pay-  
ment Devices for Tendering Payment During an Assisted  
Checkout Transaction" by Donald L. Forsythe and Horg  
Jaan Lin; Ser. No. 09/432,630, entitled "Apparatus and  
Method for Operating a Checkout System Having a Number  
of Interface Terminals Associated Therewith" by Kurt J.  
Lippert, Charles K. Wike, Jr., and Paul F. Nugent, Jr.; Ser.  
No. 09/432,628, entitled "Apparatus and Method for Oper-  
ating a Checkout System Having an RF Transmitter for Com-  
municating to a Number of Wireless Personal Paggers" by  
Robert T. Snyder; Ser. No. 09/432,631, entitled "Apparatus  
and Method for Operating a Checkout System Having an RF  
Transmitter for Communicating to a Receiver Associated  
with an Intercom System" by Robert T. Snyder and Kurt J.  
Lippert; Ser. No. 09/432,627, entitled "Apparatus and  
Method for Operating a Checkout System Having a Number  
of Item Sensors for Controlling Operation of an Input Belt  
Mechanism" by Kurt J. Lippert and Robert T. Snyder; and  
Ser. No. 09/432,629, entitled "Apparatus and Method for  
Operating a Checkout System Having a Video Camera for  
Enhancing Security During Operation Thereof" by Kurt J.

2

Lippert, each of which is assigned to the same assignee as  
the present invention, and each of which is filed concurrently  
herewith.

TECHNICAL FIELD OF THE INVENTION

The present invention relates generally to a checkout  
system, and more particularly to an apparatus and method  
for operating a checkout system having a display monitor  
which displays both transaction information and customer-  
specific messages during a checkout transaction.

BACKGROUND OF THE INVENTION

In the retail industry, the largest expenditures are typically  
the cost of the goods sold followed closely by the cost of  
labor expended. With particular regard to the retail grocery  
or supermarket industry, the impetus to reduce labor costs  
has focused on reducing or eliminating the amount of time  
required to handle and/or process the items or goods to be  
purchased by a customer. To this end, there have been a  
number of self-service checkout systems developed which  
attempt to substantially eliminate the need for a checkout  
clerk.

A self-service checkout system is operated by a customer  
without the aid of a checkout clerk. Hence, during operation  
of a self-service checkout system, the customer scans indi-  
vidual items for purchase across a scanner and then places  
the scanned item into a grocery bag, if desired. The customer  
then pays for his or her purchases either at the self-service  
checkout system if so equipped, or at a central payment area  
which is staffed by a store employee. Thus, a self-service  
checkout system permits a customer to select, itemize, and in  
some cases pay for his or her purchases without the assis-  
tance of the retailer's personnel.

It should be appreciated that a given retailer may have a  
number of reservations in regard to implementation of self-  
service checkout systems into the retailer's operation. For  
example, certain self-service checkout systems which have  
heretofore been designed are more expensive relative to  
assisted checkout systems (i.e. retail checkout systems  
which are operated by an employee of the retailer such as a  
checkout clerk). The higher cost associated with a self-  
service checkout system is typically due to the fact that the  
system itself must perform functions that would normally be  
performed by the checkout clerk operating the checkout sys-  
tem thereby increasing the number of components associ-  
ated with the self-service checkout system. For instance, in  
the case of a self-service checkout system, the system must  
provide security from improprieties such as theft. Moreover,  
in certain self-service checkout systems, the checkout sys-  
tem itself must collect payment from the customer for his or  
her items for purchase. It is the cost of the hardware and  
software necessary to provide such functions to the self-  
service checkout system which in certain cases cause the  
cost of the system to typically exceed the cost of an assisted  
checkout system.

Moreover, a number of retailers fear that the retailers cus-  
tomers may not embrace the idea of using self-service  
checkout systems to checkout their items for purchase  
thereby potentially causing the systems to go unused in the  
retailers store. In such a situation, the retailer would have  
expended a relatively substantial sum of money for a check-  
out system which is not being utilized thereby increasing  
costs associated with the retailer's operation.

Yet further, it is generally recognized that a well-trained  
checkout clerk is capable of completing a checkout transac-  
tion in a more timely manner relative to an untrained cus-

tomer. Accordingly, during periods of peak demand within the retailer's store, it is desirable for the retailer to operate a relatively large number of assisted checkout systems in order to expedite the checkout process thereby preventing customers from undesirably being forced to wait in long checkout queues. However, during periods of lesser demand within the retailer's store, it is desirable for the retailer to operate a relatively large number of self-service checkout systems in order to reduce the number of employees (i.e. checkout clerks) that the retailer must have present in the store. Hence, a compromise must be made between the number of assisted checkout systems and the number of self-service checkout systems which are installed in the retailer's store.

What is needed therefore is a checkout system which overcomes one or more of the above-mentioned drawbacks. What is particularly needed is a low-cost, easy-to-operate checkout system that may be operated as either an assisted checkout system or a self-service checkout system. What is further needed is a checkout system that may be operated as either an assisted checkout system or a self-service checkout system that can be quickly and easily converted between the two types of systems.

#### SUMMARY OF THE INVENTION

In accordance with a first embodiment of the present invention, there is provided a method of operating a retail terminal having a display monitor. The method includes the step of generating an item-entered control signal when an item for purchase is entered into the retail terminal. The method also includes the step of displaying item information associated with the item for purchase on a first portion of the display monitor in response to generation of the item-entered control signal. In addition, the method includes the step of displaying a customer-specific retail message on a second portion of the display monitor. The step of displaying the customer-specific retail message is performed contemporaneously with the step of displaying the item information associated with the item for purchase.

In accordance with a second embodiment of the present invention, there is provided a retail terminal. The retail terminal includes a display monitor and a processing unit electrically coupled to the display monitor. Moreover, the retail terminal includes a memory device electrically coupled to the processing unit. The memory device has stored therein a plurality of instructions which, when executed by the processing unit, causes the processing unit to (a) generate an item-entered control signal when an item for purchase is entered into the retail terminal, (b) display item information associated with the item for purchase on a first portion of the display monitor in response to generation of the item-entered control signal, and (c) display a customer-specific retail message on a second portion of the display monitor contemporaneously with display of the item information associated with the item for purchase on the first portion of the display monitor.

In accordance with a third embodiment of the present invention, there is provided a method of operating a retail terminal having a display monitor. The method includes the step of generating an item-entered control signal when an item for purchase of a customer is entered into the retail terminal by retail personnel. The method also includes the step of retrieving retail history information associated with the customer from a customer profile database. The method further includes the step of displaying item information associated with the item for purchase on a first portion of the display monitor in response to generation of the item-

entered control signal. Moreover, the method includes the step of displaying a customer-specific retail message based on the retail history information on a second portion of the display monitor. The step of displaying the customer-specific retail message is performed contemporaneously with the step of displaying the item information associated with the item for purchase.

It is therefore an object of the present invention to provide a new and useful checkout system.

It is moreover an object of the present invention to provide an improved checkout system.

It is a further object of the present invention to provide a new and useful method of operating a checkout system.

It is also an object of the present invention to provide an improved method of operating a checkout system.

It is yet another object of the present invention to provide a low-cost, easy-to-operate checkout system that may be operated as either an assisted checkout system or a self-service checkout system.

It is moreover an object of the present invention to provide a checkout system that may be operated as either an assisted checkout system or a self-service checkout system that can be quickly and easily converted between the two types of systems.

The above and other objects, features, and advantages of the present invention will become apparent from the following description and the attached drawings.

#### BRIEF DESCRIPTION OF THE DRAWINGS

FIG. 1 is a perspective view of a retail checkout system which incorporates the features of the present invention therein, note that the checkout system is shown configured in its assisted checkout system configuration;

FIG. 2 is a side elevational of the personnel side of the checkout system of FIG. 1;

FIG. 3 is a side elevational view of the customer side of the checkout system of FIG. 1;

FIG. 4 is a plan view of the checkout system of FIG. 1;

FIG. 5 is a view similar to FIG. 1, but showing the checkout system configured in its self-service checkout system configuration;

FIG. 6 is a side elevational of the personnel side of the checkout system of FIG. 5;

FIG. 7 is a side elevational view of the customer side of the checkout system of FIG. 5;

FIG. 8 is a plan view of the checkout system of FIG. 5;

FIGS. 9, 9A and 9B illustrate the checkout system of FIGS. 1-8;

FIGS. 10, 10A and 10B show the power distribution architecture of the checkout system of FIGS. 1-8;

FIG. 11 is a plan view similar to FIGS. 4 and 8 which shows the scanner assembly during rotation thereof;

FIG. 12 is a fragmentary perspective view of the checkout system of FIGS. 1-4 which shows the takeaway belt mechanism in its extended position;

FIG. 13 is a view similar to FIG. 12, but showing the takeaway belt mechanism in its retracted position;

FIG. 14 is a perspective view of a transaction receipt that is printed by the checkout system of FIGS. 1-8;

FIG. 15 is a view similar to FIGS. 12 and 13, but showing the set-aside shelf positioned in its self-service position;

FIG. 16 is a plan view similar to FIG. 4 which shows a shopping cart and basket positioned proximate to the checkout system;

FIG. 17 is a fragmentary perspective view of the checkout system of FIG. 1 which shows a "flatbed" scanner which may be utilized in the construction of the checkout system;

FIG. 18 is a perspective view of the support arm assembly which is utilized to support the interactive customer interface terminal of the checkout system of FIGS. 1-8;

FIG. 19 is a plan view which shows the interactive customer interface terminal positioned in its assisted position;

FIG. 20 is a view similar to FIG. 19, but showing the interactive customer interface terminal positioned in its self-service position;

FIG. 21 is an enlarged perspective view of the interactive customer interface terminal of the checkout system of FIGS. 1-8;

FIG. 22 is a simplified block diagram of the paging system of the checkout system of FIGS. 1-8;

FIG. 23 is a perspective view which shows the personnel interface terminal of the checkout system of FIGS. 1-8 in its assisted position;

FIG. 24 is a view similar to FIG. 23, but showing the personnel interface terminal in its self-service position;

FIG. 25 is a flowchart which shows a general procedure or routine for operating the checkout system of the present invention in its assisted mode of operation;

FIG. 26 is a flowchart which shows the scale security routine for providing security during operation of the checkout system of the present invention;

FIG. 27 is a flowchart which shows the video security routine for providing security during operation of the checkout system of the present invention;

FIG. 28 is a flowchart which shows a general procedure or routine for operating the checkout system of the present invention in its self-service mode of operation;

FIG. 29 is view similar to FIG. 1, but showing an alternative embodiment of a terminal cabinet which may be utilized in certain configurations of the checkout system of the present invention;

FIG. 30 is a perspective view of a first embodiment of a self-service checkout system which incorporates the features of the present invention therein; and

FIG. 31 is a view similar to FIG. 30, but showing a second embodiment of a self-service checkout system which incorporates the features of the present invention therein.

#### DETAILED DESCRIPTION OF THE INVENTION

While the invention is susceptible to various modifications and alternative forms, specific embodiments thereof have been shown by way of example in the drawings and will herein be described in detail. It should be understood, however, that there is no intent to limit the invention to the particular forms disclosed, but on the contrary, the intention is to cover all modifications, equivalents, and alternatives falling within the spirit and scope of the invention as defined by the appended claims.

Referring now to FIGS. 1-8, there is shown a retail checkout terminal or system 10 for use in a retail business such as a grocery store. The checkout system 10 is configured to perform a number of retail functions such as assisted checkout functions and unassisted or "self-service" checkout functions. What is meant herein by the term "assisted checkout functions" or "assisted checkout transactions" are those checkout functions or transactions performed by a checkout system when the checkout system is being operated by retail personnel such as a clerk or associate which is employed by

the retailer to operate the checkout system. For example, an assisted checkout function or transaction would be performed by the checkout system 10 in response to a store-employed clerk scanning or otherwise entering a customer's items for purchase into the checkout system, and thereafter depressing a payment-received key on the checkout system which indicates that the customer paid for such items. Accordingly, what is meant herein by the phrase "assisted mode of operation" is a configuration of the checkout system 10 which allows the system 10 to perform an assisted checkout function or transaction.

Moreover, what is meant herein by the term "self-service checkout functions" or "self-service checkout transactions" are those checkout functions or transactions which are performed by a checkout system by the customer himself or herself without the assistance of a clerk or other personnel employed by the retailer. For example, a self-service checkout function or transaction would be performed by the checkout system 10 in response to a customer himself or herself scanning or otherwise entering items for purchase into the checkout system, and thereafter depressing a payment key on the checkout system which indicates the manner by which the customer intends to pay for such items (e.g. by interaction with a credit/debit card reader or a currency acceptor). Accordingly, what is meant herein by the phrase "self-service mode of operation" is a configuration of the checkout system 10 which allows the system 10 to perform a self-service checkout function or transaction.

In addition, what is meant herein by the term "customer" is a person who enters a retailer's store, selects his or her items for purchase from the shopping area of the store, checks out his or items for purchase at a checkout system such as the checkout system 10 (including tendering payment for his or her items for purchase), and then exits the store subsequent to tendering payment. Hence, as used herein, a customer is distinguished from retail personnel such as a checkout clerk or other employee of the retailer in that a customer enters the retailer's store for the sole purpose of purchasing items from the store. Moreover, what is meant herein by the term "retail personnel" is a person that is employed by the retailer to perform a retail activity such as operation of a checkout system such as the checkout system 10 for the purpose of conducting a retail transaction such as an assisted checkout transaction. Examples of retail personnel include a checkout clerk or customer service manager. Also, the term "user" is herein used to refer to any operator of the checkout system 10. Accordingly, a user may be retail personnel, a customer, or any other person who operates the checkout system 10.

The checkout system 10 includes a pre-scan area 12, an itemization area 14, a payment area 16, and a post-scan area 18. The pre-scan area 12 includes an item transport mechanism such as an input belt mechanism 20 which includes an input belt 22. As will be discussed below in greater detail, the input belt mechanism 20 is utilized to convey items for purchase toward the itemization area 14 in order for the items to be scanned by a user of the checkout system 10.

The pre-scan area 12 also includes an upstream item sensor 98 and a downstream item sensor 100. The item sensors 98, 100 are preferably embodied as known photodetector devices which are capable of detecting presence of an item at predetermined locations on the input belt 22 when a light beam respectively generated the sensors 98, 100 is interrupted by an item. However, it should be appreciated that the item sensors 98, 100 may alternatively be embodied as any type of sensor which is capable of detecting presence of items on the input belt 22. The item sensors 98, 100 are

provided to facilitate item movement from an upstream location to a downstream location on the input belt 22. The terms “upstream” and “downstream” are used herein to be consistent with the flow of items through the checkout system 10 during a typical checkout procedure. In particular, an item enters at the area proximate the pre-scan 12 then flows in a downstream direction to be scanned or otherwise entered at the itemization area 14. Once the item is scanned or otherwise entered at the itemization area 14, the item flows from the itemization area 14 in a downstream direction to the post-scan area 18.

The upstream item sensor 98 is provided to determine when a customer places an item on an upstream end portion 22a of the input belt 22. Although only a single item sensor 98 is shown in FIGS. 1–8, it should be appreciated that any number of item sensors 98 may be utilized so as to detect item placement at any location on the upstream end portion 22a of the input belt 22. As described below in greater detail, once the item sensor 98 detects presence of an item on the upstream end portion 22a of the input belt 22, the motor (not shown) associated with the input belt mechanism 20 is actuated so as to advance the input belt 22 thereby causing the item to be advanced in a downstream direction toward the itemization area 14. More specifically, actuation of the motor associated with the input belt mechanism 20 causes the item to be advanced in a downstream direction until it reaches a predetermined location at a downstream end portion 22b of the input belt. As can be seen in FIGS. 4 and 8, the downstream end portion 22b of the input belt 22 is upstream of the itemization area 14. Once the item is advanced to the predetermined location at the downstream end portion 22b of the input belt 22, presence of the item is detected by the downstream item sensor 100 which in turn causes the motor associated with the input belt mechanism 20 to be deactivated thereby halting advancement of the item at a position in which the item can be easily scanned or otherwise entered by a customer (in the case of when the checkout system 10 is being operated in its self-service mode of operation) or a checkout clerk (in the case of when the checkout system 10 is being operated in its assisted mode of operation).

The itemization area 14 of the checkout system includes a scanner 24 and a product scale 26. The scanner 24 conventionally scans or reads a product identification code such as a Universal Product Code (UPC), industrial symbol(s), alphanumeric character(s), or other indicia associated with an item to be purchased. One scanner which may be used in the present invention is a model number 7875 bi-optic scanner which is commercially available from NCR Corporation of Dayton, Ohio.

The scanner 24 includes a first scanning window 24a and a second scanning window 24b. The first scanning window 24a is disposed in a substantially horizontal manner, whereas the second scanning window 24b is disposed in a substantially vertical manner, as shown in FIG. 2. More specifically, the checkout system 10 includes a number of cabinets 28, 30, 32. A portion of the cabinets 28, 30, 32 define a terminal base 34 which has a substantially horizontal upper surface 36. As shown in FIGS. 1 and 5, the horizontal scanning window 24a is disposed in a relatively flush-mount arrangement with the upper surface 36 of the terminal base 34. Moreover, the product scale 26 is integrated with the scanner 24. More specifically, the product scale 26 is disposed substantially parallel to the upper surface 36 of the terminal base 34 and hence the horizontal scanning window 24a thereby enveloping the horizontal scanning window 24a. If an item such as produce is placed upon the product scale

26 or the horizontal scanning window 24a, the product scale 26 may be used to determine the weight of the item.

The scanner 24 also includes a light source (not shown) such as a laser, a rotating mirror (not shown) driven by a motor (not shown), and a mirror array (not shown). In operation, a laser beam reflects off the rotating mirror and mirror array to produce a pattern of scanning light beams. As the product identification code on an item is passed over the scanner 24, the scanning light beams scatter off the code and are returned to the scanner 24 where they are collected and detected. The reflected light is then analyzed electronically in order to determine whether the reflected light contains a valid code pattern. If a valid code pattern is present, the product identification code may then be utilized to retrieve product information associated with the item (e.g. the price of the item).

The scanner 24 and the product scale 26 are movably mounted to the terminal base 34. In particular, the scanner 24 and the product scale 26 are rotatably mounted to a support platform such as a sliding drawer assembly 38. Use of the sliding drawer assembly 38 allows the scanner 24 and the product scale 26 to be rotated relative to the terminal base 34 so as to be operated by either a customer or a checkout clerk. In particular, as shown in FIG. 11, the sliding drawer assembly 38 may be slid out from the terminal base 34 into its extended position such that the scanner 24 (and hence the product scale 26) may be rotated between an assisted scanner position (see FIGS. 1–4) in which the scanner 24 is operable by a checkout clerk, and a self-service scanner position (see FIGS. 5–8) in which the scanner 24 is operable by a customer. Thereafter, the sliding drawer assembly is slid back into its retracted position within the interior of the terminal base 34 such that operation of the scanner 24 by the checkout clerk or the customer may be commenced.

As shown in FIGS. 4 and 8, the checkout system 10 has a customer side 40 and a personnel side 42. More specifically, the terminal base 34 divides the checkout system 10 into the customer side 40 which is the side of the checkout system 10 where the customer is positioned during a checkout transaction, and the personnel side 42 which is the side of the checkout system 10 where retail personnel such as a checkout clerk is located during a checkout transaction. A customer is positioned on the customer side 40 of the checkout system 10 irrespective of whether the system 10 is being operated to perform an assisted checkout transaction or a self-service checkout transaction, whereas retail personnel is at all times positioned on the personnel side 42 of the checkout system 10. Use of the rotating scanner 24 facilitates such “same side” operation of the checkout system 10. In particular, as shown in FIGS. 1–4, rotation of the scanner 24 into its assisted scanner position causes the vertical scanning window 24b to face the personnel side 42 of the checkout system 10, whereas rotation of the scanner 24 into its self-service scanner position causes the vertical scanning window 24b to face the customer side 40 of the checkout system 10 (see FIGS. 5–8). Such a system configuration (i.e. use of the rotating scanner 24 to cause the customer to be positioned on the customer side 40 of the checkout system 10 irrespective of whether the system 10 is being operated to perform an assisted checkout transaction or a self-service checkout transaction, and retail personnel to be positioned on the personnel side 42 of the checkout system 10) is particularly useful for enhancing system component layout and system placement within the store.

The itemization area 14 also includes a security deactivation device 172 (see FIGS. 4 and 8). The security deactivation device 172 is provided to deactivate or otherwise disable

security tags associated with an electronic article surveillance (EAS) system. In particular, certain items sold by the retailer may have an electronic tag secured thereto. Such electronic tags are generally a label or "clip-on" mechanism which has an electronic transponder imbedded therein which triggers an alarm if the item is taken from the retailers store without the tag being deactivated or otherwise disabled beforehand. It should be appreciated that such tags are generally secured to items that are expensive in nature, but as the cost associated with such electronic tags continues to decrease, more and more items associated with a given retail operation may be equipped with such electronic tags.

In any event, the electronic tags associated with EAS systems are deactivated by exposing the tag to a magnetic field or an electromagnetic field such as an RF field. The security deactivation device 172 of the present invention generates such a magnetic field or electromagnetic field during operation of the checkout system 10 so as to deactivate electronic tags associated with items for purchase as the items are scanned with the scanner 24. In particular, the security deactivation device 172 generates a deactivation field (e.g. a magnetic and/or electromagnetic field) proximate to a scanner detection zone associated with the scanner 24. What is meant herein by the term "scanner detection zone" is the area proximate the scanning windows 24a, 24b of the scanner 24 which defines the maximum range in which an item can be successfully scanned as it is passed across the scanner 24. Security deactivation devices which are suitable for use as the security deactivation device 172 of the present invention are commercially available from Checkpoint Systems, Incorporated of Thorofare, New Jersey (in the case of an RF field generator) and Sensormatic Electronics Corporation of Boca Raton, Florida (in the case of a magnetic field generator).

By generating the deactivation field proximate to the scanner detection zone, a scanning motion utilized to scan an item with the scanner 24 causes the item to be advanced through the deactivation field thereby deactivating the electronic security tag secured to the item in the same scanning motion. Such utilization of the security deactivation device 172 is particularly useful when the checkout system 10 is being operated in its self-service mode of operation. In particular, by "automatically" deactivating the electronic security tag when the item is being scanned by a customer (i.e. deactivating the tag during a scanning motion), the customer is not required to perform additional operations for the sole purpose to deactivating the tag prior to exiting the store. In particular, heretofore designed self-service checkout systems have required the customer to take his or her items for purchase to a centralized area such as a terminal operated by a retail clerk after the customer has completed his or her transaction in order to allow the clerk to determine which of the customer's items contain electronic security tags that need to be deactivated. Thereafter, the clerk manually deactivates each of the electronic security tags associated with the customer's items for purchase. It should be appreciated that the extra step of requiring the customer to take his or her items to the centralized area to deactivate the electronic security tags adds cost to the retailers operation (e.g. the cost associated with staffing the centralized area with a retail clerk) and also creates an inconvenience for the customer by requiring the customer to spend additional time in the retailers store. Such an inconvenience to the customer is augmented if a line or queue is present at the centralized area.

Utilization of the security deactivation device 172 of the present invention solves such shortcomings of heretofore self-service checkout systems by deactivating the electronic

security tag as part of routine entry of items into the checkout system 10 by the customer. In particular, utilization of the security deactivation device 172 eliminates the need for the retail clerk to intervene into the customers transaction thereby reducing labor costs associated with the retailer's operation, along with increasing convenience to the customer by not requiring him or her to stand in a potentially long line or queue. Moreover, by generating the deactivation field proximate to the scanner detection zone such that the electronic security tag is deactivated as a result of an item scanning motion, the customer is not required to operate a separate deactivation device such as a magnetic pad or the like thereby reducing the number of components that a customer is presented with during operation of the checkout system 10 in its self-service mode of operation.

It should be appreciated that the security deactivation device 172 may be configured to continuously generate the deactivation field (e.g. the magnetic or electromagnetic field), or may only generate the deactivation field once the product code associated with the item has been captured by the scanner 24. In particular, under the premise that if the customer is making an attempt to scan the item, the customer is likely not trying to commit an impropriety such as theft, the security deactivation device 172 may be configured to continuously generate the deactivation field such that the electronic security tag is deactivated irrespective of whether or not the product code associated with the item is actually captured with the scanner 24. For example, if the customer attempts to scan the item with the scanner 24 (by advancing the item through the scanner detection zone with the bar code associated with the item facing one of the scanning windows 24a, 24b), but the product code is not captured by the scanner 24 for any reason, the security deactivation device 172, if configured to continuously produce the deactivation field, causes the electronic security tag to be deactivated even though the item was not actually entered in the checkout system 10. However, in the case of operation of the checkout system 10 by an honest customer, such premature deactivation of the security tag is not an issue once the customer is subsequently successful at entering the item (e.g. by re-scanning the item or manually entering the product code). It should be appreciated that the customer is likely to perform such re-scanning or manual entry of the item since the customer is not generally made aware of the fact that the electronic security tag has been deactivated.

However, to prevent the unlikely occurrence that the electronic security tag is prematurely deactivated without the item being subsequently entered in the checkout system 10, the security deactivation device 172 may be configured to generate the deactivation field only after the product code associated with the item has been entered into the checkout system 10. In particular, a control signal is generated when a product code associated with an item is captured by the scanner 24. In response to generation of such a control signal, the security deactivation device 172 may be instantaneously actuated so as to generate a deactivation field thereby deactivating the electronic security tag associated with the scanned item. In such a configuration, the location, width, and/or shape of the deactivation field generated by the security deactivation device 172 may be configured to ensure that the item is advanced therethrough during a scanning motion or subsequent handling motion (e.g. the motion associated with placement of the item into the post-scan area 18).

As shown in FIGS. 1 and 5, the payment area 16 of the checkout system 10 includes the system components necessary to allow a customer to perform retail finalization functions such as tendering payment for his or her items for

purchase and printing of transaction receipts. In particular, the payment area 16 of the checkout system 10 includes an electronic payment terminal 44 having a card reader and keypad, a pair of currency acceptors such as a coin acceptor 46 and a bill acceptor 50, a corresponding pair of currency dispensers such as a coin dispenser 48 and a bill dispenser 52, and a receipt printer 54. As shown in FIG. 1, the system components associated with the payment area 16 are positioned to face the customer side 40 of the checkout system 10 so as to be accessible to a customer during a checkout transaction.

The system components associated with the payment area 16 of the checkout system 10 are provided to allow the customer to tender payment for his or her items for purchase when the checkout system 10 is being operated in its self-service mode of operation. In particular, once the customer has entered all of his or her items for purchase into the checkout terminal 10 during a self-service checkout transaction, the components associated with the payment area 16 are utilized to complete the self-service checkout transaction by (1) allowing payment to be tendered by either insertion of currency into a currency acceptor (i.e. the coin acceptor 46 and/or the bill acceptor 50), charging a credit card or debit card account, or decreasing a value amount stored on a smart card via the electronic payment terminal 44, and (2) printing a transaction receipt with the receipt printer 54. In the case of when a customer inserts currency into the coin accept 46 and/or the bill acceptor 50, the checkout system 10 may provide change via a currency dispenser (i.e. the coin dispenser 48 and/or the bill dispenser 52).

However, the system components associated with the payment area 16 of the checkout system 10 are also provided to enhance the efficiency and throughput associated with operation of the checkout system 10 in its assisted mode of operation. In particular, once the checkout clerk operating the checkout system 10 to perform the assisted checkout transaction has entered the last of the customer's items for purchase, the system components associated with the payment area 16 may be utilized to finalize or otherwise complete the customers transaction without additional intervention or assistance from the checkout clerk. In particular, as the checkout clerk begins to enter items associated with a subsequent checkout transaction, the customer may tender payment for the previous checkout transaction by either inserting currency into a currency acceptor (i.e. the coin acceptor 46 and/or the bill acceptor 50), charging a credit card or debit card account, or decreasing a value amount stored on a smart card via the electronic payment terminal 44. In the case of when a customer inserts currency into the coin acceptor 46 and/or the bill acceptor 50, the checkout system 10 may provide change via a currency dispenser (i.e. the coin dispenser 48 and/or the bill dispenser 52). Thereafter, a transaction receipt is printed by the receipt printer 54 for presentation to the customer without assistance from retail personnel.

As described, use of the system components associated with the payment area 16 of the checkout system 10 provides numerous advantages to the checkout system 10 of the present invention. For example, by operating the checkout system 10 such that payment is tendered by the customer by use of the currency acceptor (i.e. the coin acceptor 46 and/or the bill acceptor 50) or the electronic payment device 44 without the assistance of the checkout clerk allows the checkout clerk to begin a subsequent transaction while the customer completes the current transaction thereby enhancing the efficiency and throughput associated with the checkout system 10. Similarly, operation of the electronic pay-

ment terminal 44 and generation of the transaction receipt on the customer side 40 of the checkout system 10 allows the customer to complete his or her transaction without further assistance from the checkout clerk thereby further enhancing the efficiency and throughput associated with the checkout system 10.

The post-scan area 18 includes an item transport mechanism such as a takeaway belt mechanism 56 having a takeaway belt 58. Moreover, the post-scan area 18 includes a self-service bagwell 60 (see FIG. 1) and an assisted bagwell 62 (see FIGS. 2 and 6). The bagwells 60, 62 are provided to accommodate one or more grocery containers such as grocery bags (not shown). In particular, the self-service bagwell 60 is configured to allow two or more grocery bags to be accessed by the customer at any given time thereby allowing a customer to selectively load various item types into the grocery bags during operation of the checkout system 10 in its self-service mode of operation. For example, during a self-service checkout transaction, the customer may desire to use a first grocery bag for household chemical items such as soap or bleach, and a second grocery bag for edible items such as meat and produce in order to keep the two types of items separate.

Similarly, the assisted bagwell 62 is configured to allow two or more grocery bags to be accessed by the checkout clerk at any given time thereby allowing the clerk to selectively load various item types into the grocery bags during operation of the checkout system 10 in its assisted mode of operation. Such a configuration of the assisted bagwell 62 is particularly useful when the checkout system 10 is being operated by a checkout clerk to perform an "express" checkout transaction in which the total number of items for purchase in the transaction is relatively small and can therefore be bagged in a small number of grocery bags.

The takeaway belt mechanism 56 is provided to transport items which have been scanned with the scanner 24 or otherwise entered into the checkout system 10 to a bagging counter 66 where the items are placed into grocery bags or the like by a bagging clerk. Hence, as described herein, the self-service bagwell 60, the assisted bagwell 62, and the bagging counter 66 define the three bagging stations associated with the checkout system 10. The takeaway belt 58 of the takeaway belt mechanism 56 is slidably secured to the terminal base 34. In particular, the takeaway belt 58 may be slid between an extended position (see FIG. 12) and a retracted position (see FIG. 13). As shown in FIG. 13, when the takeaway belt 58 is positioned in its retracted position, an end portion 58a of the takeaway belt 58 is spaced apart from the scanner 24 so as to expose an overhead access opening 62a associated with the assisted bagwell 62 in order to allow the checkout clerk operating the scanner 24 to place an item into a grocery bag within the assisted bagwell 62 once the item has been scanned.

Conversely, as shown in FIG. 12, when the takeaway belt 58 is positioned in its extended position, the end portion 58a of the takeaway belt 58 is positioned proximate to the scanner 24 in order to cover the overhead access opening 62a associated with the assisted bagwell 62. Positioning the takeaway belt 58 in its extended position allows the checkout clerk operating the scanner 24 to place an item onto the takeaway belt 58 once the item has been scanned thereby allowing the item to be transported to the bagging counter 66 by the takeaway belt mechanism 56.

Hence, what is meant herein by the term "overhead access opening" is a substantially downward ingress into one of the bagwells 60, 62 which allows an item to be advanced in a



13

substantially downward direction into one of the grocery bags positioned in the bagwell 60, 62. For example, as shown in FIG. 13, the overhead access opening 62a associated with the assisted bagwell 62 is exposed when the take-away belt 58 is positioned in its retracted position thereby allowing the checkout clerk operating the scanner 24 to advance an item in a substantially downward direction into a grocery bag positioned within the assisted bagwell 62. However, as shown in FIG. 12, the overhead access opening 62a associated with the assisted bagwell 62 is covered when the takeaway belt 58 is positioned in its extended position thereby preventing the checkout clerk from advancing an item in a substantially downward direction into the assisted bagwell 62.

The post-scan area 18 also includes a security scale 68. The security scale 68 is a weight scale which monitors the weight of items placed in either the self-service bagwell 60 (i.e. into a grocery bag located in the bagwell 60) or the assisted bagwell 62 (i.e. into a grocery bag located in the bagwell 62). As shall be discussed below in greater detail, in addition to providing security by monitoring item movement into and out of the self-service bagwell 60 during a self-service checkout transaction, the security scale 68 is also utilized to provide security by monitoring item movement into and out of the assisted bagwell 62 during an assisted checkout transaction. Such monitoring during an assisted checkout transaction is particularly useful to prevent "sweethearting" in which the checkout clerk scans a first item, but then places a second, more expensive item (or an item which hasn't been scanned at all) into the customer's bag. Such "sweethearting" is generally the result of a checkout clerk attempting to provide an improper benefit to a customer who is an acquaintance of the checkout clerk. Use of a bagwell scale has heretofore only been included in dedicated self-service checkout system designs. However, since the checkout system 10 of the present invention includes the security scale 68 for monitoring item movement during self-service checkout transactions, the same scale (i.e. the security scale 68) can be utilized in a novel manner by the systems and methods described herein to provide the aforescribed security during assisted checkout transactions without adding additional costs to the design of the checkout system 10.

The post-scan area 18 of the checkout system further includes a set-aside shelf 70. The set-aside shelf 70 is positionable in either an assisted shelf position (see FIGS. 1, 12, and 13) or a self-service shelf position (see FIGS. 5 and 15). The set-aside shelf 70 is provided to allow a user of the system 10 (e.g. either a customer or a checkout clerk) to set an item aside once the item has been scanned or otherwise entered into the system 10, but prior to placing the item into a grocery bag within one of the bagwells 60, 62. For example, if the checkout system 10 is being operated in its self-service mode of operation, and a customer scans a loaf of bread, the customer may want to place the bread onto the set-aside shelf 70 until one of the grocery bags within the self-service bagwell 60 is nearly full thereby preventing the bread from being crushed. Moreover, a vertical support structure 72 (see FIGS. 1 and 5) mechanically couples the set-aside shelf 70 to a lower support surface 74 of the bagwells 60, 62, which is in turn mechanically coupled to the input plate or tray of the security scale 68. Hence, in addition to monitoring placement and removal of items into and out of the bagwells 60, 62, the security scale 68 is also utilized to monitor placement and removal of items onto and off of the set-aside shelf 70.

The set-aside shelf 70 is movably secured to the terminal base 34 so that a single shelf may be utilized by both retail

14

personnel (when the checkout system 10 is being operated in its assisted mode of operation) and the customer (when the checkout system 10 is being operated in its self-service mode of operation). For example, the set-aside shelf 70 may be secured to the terminal cabinet 30 by use of a sliding rail assembly so as to allow the shelf 70 to be slid between its assisted position (see FIGS. 1, 12, and 13) and its self-service position (see FIGS. 5 and 15). Alternatively, the set-aside shelf 70 may be secured to the terminal cabinet 30 by use of a hinge assembly 70a (see FIGS. 3 and 5) so as to allow the shelf 70 to be pivoted between its assisted position and its self-service position.

Moreover, the set-aside shelf 70 selectively covers and exposes the respective overhead access openings of the bagwells 60, 62 as the shelf 70 is moved between its assisted shelf position (see FIGS. 1 and 13) or a self-service shelf position (see FIGS. 5 and 15). In particular, as shown in FIG. 13, the overhead access opening 62a associated with the assisted bagwell 62 is exposed when the set-aside shelf 70 is positioned in its assisted shelf position thereby allowing the checkout clerk operating the scanner 24 to advance an item in a substantially downward direction into a grocery bag positioned within the assisted bagwell 62. However, as shown in FIG. 1, a portion of an overhead access opening 60a associated with the self-service bagwell 60 is covered when the set-aside shelf 70 is positioned in its assisted shelf position.

Conversely, as shown in FIGS. 5 and 15, the overhead access opening 60a associated with the self-service bagwell 60 is exposed when the set-aside shelf 70 is positioned in its self-service shelf position thereby allowing the customer operating the scanner 24 to advance an item in a substantially downward direction into a grocery bag positioned within the self-service bagwell 60. However, as shown in FIG. 15, the overhead access opening 62a associated with the assisted bagwell 62 is covered when the set-aside shelf 70 is positioned in its self-service shelf position.

As discussed above, the security scale 68 may be utilized to provide security to the checkout system 10 during operation thereof in either its self-service mode of operation or its assisted mode of operation. In particular, the security scale 68 is utilized to monitor the ingress and egress of items into and out of the post-scan area 18. More specifically, the security scale 68 is utilized to detect placement of items (1) into and out of the bagwells 60, 62, and (2) onto and off of the set-aside shelf 70a. Such item movement monitoring may be utilized to determine if the customer is unintentionally or intentionally committing an impropriety such as theft. For example, a control signal is generated when the scanner 24 successfully captures a product code associated with an item being entered into the checkout system 10. The security scale 68 may be used to detect placement of an item into the post-scan area 18 prior to generation of the control signal thereby enabling detection of the situation in which an unscanned item has been placed into a grocery bag or onto the set-aside shelf 70.

Moreover, when an item is scanned with the scanner 24 and thereafter placed in the post-scan area 18, the detected weight of the item (as detected by the security scale 68) may be compared to a known weight value of the item that is stored in a database in order to confirm that a different, more expensive item was not substituted for the scanned item. It should be appreciated that the database may be in the form of a master database which includes every item sold by the retailer, or may be a "transaction level" database which is constructed locally at the checkout system 10 during operation thereof.

It should be appreciated that a number of security schemes utilizing the security scale **68** may be employed during operation of the checkout system **10** in both its self-service mode of operation and its assisted mode of operation. Examples of security schemes utilizing a security scale that is somewhat similar to the security scale **68** in a self-service checkout system are disclosed in U.S. Pat. No. 5,952,642 entitled "Method and Apparatus for Detecting Item Substitutions During Entry of an Item into a Self-Service Checkout Terminal" by Dusty Lutz, which was issued on Sep. 14, 1999, along with copending U.S. Patent applications Ser. No. 08/990,241 entitled "Method and Apparatus for Detecting Item Placement and Item Removal During Operation of A Self-Service Checkout Terminal" which was filed on Dec. 15, 1997, by Jim Morrison and Dusty Lutz; and Ser. No. 09/071,024 entitled "Method of Monitoring Item Stuffing in a Post-Scan Area of a Self-Service Checkout Terminal" which was filed on May 1, 1998, by Dusty Lutz, Chris Malchak, Tim Mason, Ali Vassigh. The disclosures of the above-identified issued patent along with each of the above-identified patent applications are hereby incorporated by reference, and are assigned to the same assignee as the present invention.

The checkout system **10** also includes a pair of user interface terminals for receiving input from and providing information to a user. In particular, the checkout system **10** includes personnel interface terminal **76** (see FIG. 2) and an interactive customer interface terminal **78** (see FIG. 1). The personnel interface terminal **76** includes a display monitor **76a** and a keypad **76b** (see FIG. 23). Transaction information such as item price, item description, total amount of the transaction, instructions, etcetera is displayed to the checkout clerk via the display monitor **76a** during operation of the checkout system **10** by the clerk. Moreover, the checkout clerk may manually enter retail information such as item codes and quantities into the checkout system **10** by use of the keypad **76b** associated with the personnel interface terminal **76**. The personnel interface terminal **76** of the present invention may be embodied as a single, integrated device (as shown in FIG. 23) having both the display monitor **76a** and the keypad **76b**, or alternatively, the display monitor **76a** and the keypad **76b** may be embodied as separate components. One integrated terminal which is particularly useful as the personnel interface terminal **76** of the present invention is a Dynakey terminal which is commercially available from NCR Corporation.

As discussed above, the personnel interface terminal **76** is provided for use by the checkout clerk when the checkout system **10** is being operated in its assisted mode of operation. As shall be discussed below in more detail, the interactive customer interface terminal **78** is provided for use by customer when the checkout system **10** is being operated in both its assisted mode of operation and its self-service mode of operation. Accordingly, the personnel interface terminal **76** is generally not utilized by the customer when the checkout system **10** is being operated in its self-service mode of operation.

Hence, the personnel interface terminal **76** is secured to the terminal base **34** in a manner which allows the display monitor **76a** and the keypad **76b** to face the personnel side **43** of the system **10** at all times during operation of the checkout system **10**. In particular, as shown in FIGS. 23 and 24, the personnel interface terminal **76** is secured to a terminal support member **80**. The terminal support member **80** is pivotally secured to a scanner housing **82** which houses the vertical scanning window **24b** of the scanner **24**. Such a mounting configuration allows the terminal support member

**80** (and hence the personnel interface terminal **76**) to rotate relative to the housing **82** (and hence the scanner **24**). More specifically, as the scanner **24** (and hence the housing **82**) is rotated between the assisted scanner position (see FIG. 1) and the self-service scanner position (see FIG. 5), the terminal support member **80** (and hence the personnel interface terminal **76**) may be rotated relative to the housing **82** such that the display monitor **76a** and the keypad **76b** face the personnel side **42** of the checkout system **10** irrespective of whether the scanner **24** is positioned in its assisted scanner position or its self-service scanner position.

Such a configuration in which the display monitor **76a** and the keypad **76b** of the personnel interface terminal **76** face the personnel side **42** of the checkout system **10** irrespective of whether the scanner **24** is positioned in its assisted scanner position or its self-service scanner position provides numerous advantages to the checkout system **10**. For example, facing the keypad **76b** away from the customer when the checkout system **10** is being operated in its self-service mode of operation prevents the customer from becoming confused by the presence of the keypad **76b** thereby eliminating the possibility that the customer attempts to operate the personnel interface terminal **76**. Moreover, facing the keypad **76b** away from the customer when the checkout system **10** is being operated in its self-service mode of operation reduces the number of components which are presented to the customer thereby reducing or eliminating any potential intimidation associated with first time performance of a self-service checkout transaction.

Yet further, facing the display monitor **76a** and the keypad **76b** of the personnel interface terminal **76** toward the personnel side **42** of the checkout system **10** when the scanner **24** is positioned in both its assisted scanner position and its self-service scanner position allows a surface **80a** of the terminal support member **80** to face the customer side **40** of the checkout system **10**. The surface **80a** may be utilized to display messages to the customer. More specifically, as shown in FIG. 24, a **10** laminated sign **80b** or the like may be secured to the surface **80a** of the terminal support member **80** with fasteners or the like (not shown) in order for the message printed on the sign **80b** to be displayed to the customer. Such a message may include an advertisement for a product or service offered by the retailer. Moreover, the retailer may sell the space on the laminated sign **80b** to an outside company or business (e.g. a real estate agent or mortgage broker) in order to generate additional revenue. The message printed on the sign **80b** may alternatively, or in conjunction, include instructions which instruct the customer on operation of the checkout system **10**.

As shown in FIG. 21, the interactive customer interface terminal **78** includes a display monitor **78a** which is provided to display retail information to the customer during operation of the checkout system **10**. For example, transaction information such as item price, item description, total amount of the transaction, instructions, etcetera is displayed to the customer via the display monitor **78a** during operation of the checkout system **10** in either its assisted mode of operation or its self-service mode of operation. Moreover, instructions are displayed on the display monitor **78a** which assist or otherwise guide the customer through operation of the checkout system **10**. Such instructions are particularly useful when the checkout system **10** is being operated in its self-service mode of operation.

Moreover, customer-specific messages may be displayed to the customer on the display monitor **78a** at certain times during a checkout transaction. What is meant herein by the term "customer-specific" is regard to messages is a retail

message that is customized for a given customer based on the purchasing habits or other information that is unique to the customer. For example, a customer-specific message may include a customer-specific advertisement which advertises a product that was purchased by the customer during a previous visit to the retailer's store. As shall be discussed below in greater detail, the checkout system **10** of the present invention is configured to retrieve information from a customer profile database which contains such information (e.g. previous purchases) about each of the retailers customers. Moreover, a customer-specific message may include a customer-specific advertisement that advertises a product which may be used in conjunction with a product that was previously scanned or otherwise entered into the checkout system **10** during the current checkout transaction. For example, if the checkout clerk scans a case of beer that is included in the customer's items for purchase, an advertisement relating to pretzels may be displayed to the customer on the display monitor **78b** since pretzels are commonly consumed with beer.

It should be appreciated that such customer-specific messages may also be communicated by other components associated with the checkout system **10**. For example, customer-specific messages may be displayed to the checkout clerk via the display monitor **76a** of the personnel interactive terminal **76**. For instance, if the checkout clerk scans a case of beer or other type of alcohol, a customer-specific message may be displayed on the display monitor **76a** which informs the checkout clerk that the customer is not old enough to purchase the beer or other type of alcohol. Similarly, customer-specific advertisement messages could be displayed on the display monitor **76a** in order to be verbally relayed or otherwise communicated to the customer in a personal manner by the checkout clerk.

Referring back to the discussion regarding the interactive customer interface terminal **78**, the display monitor **78a** is preferably a known touch screen monitor which can generate data signals when certain areas of the screen are touched by a customer. Hence, the display monitor **78a** may be utilized by the customer to input information into the checkout system **10**. For example, the customer may manually enter retail information such as item codes and quantities into the checkout system **10** by use of the touch screen associated with the display monitor **78a**. The customer may indicate his or her preferred method of payment (e.g. cash, credit, or debit card) by touching the appropriate area of the touch screen associated with the display monitor **78a**. A portion of the touch screen associated with the display monitor **78a** may also be utilized as a "help button" such that assistance is provided to the customer when it is touched by the customer.

Moreover, the interactive customer interface terminal **78** is preferably embodied as a stand-alone, kiosk-type device which is, in essence, a modified flat panel personal computer (PC) which includes a number of components commonly associated therewith such as a processing unit **78b** having a microprocessor **78c** (see FIG. **9**) and a number of memory modules **78d** (see FIG. **9**) associated therewith, along with other commonly utilized PC components such as an Ethernet controller, a number of video and audio control devices, a storage memory device such as a hard drive device, and a number of connector ports for coupling the interface terminal **78** to a number of retail peripheral devices such as the scanner **24** and the product scale **26**. Hence, in addition to displaying transaction information to the customer, the interactive customer interface terminal **78** functions as the main processing device or controller for controlling operation of the checkout system **10**. It should be appreciated that the

interactive customer interface terminal **78** may be embodied as any stand-alone, kiosk-type device which includes the aforescribed components (e.g. a display monitor, PC, etcetera). One such stand-alone, kiosk-type device which is particularly useful as the interactive customer interface terminal of the present invention is an Informa model information terminal which is commercially available from NCR Corporation.

As shown in FIGS. **18-20**, the interactive customer interface terminal **78** is movably secured to the upper surface **36** of the terminal base **34** by a support arm assembly **160**. As shown in FIG. **18**, the support arm assembly **160** includes a first support arm **162** and a second support arm **164**. The support arm assembly **160** is configured to allow the interactive customer interface terminal **78** to be pivoted relative to the upper surface **36** of the terminal base **34** along a pair of substantially-vertical pivot axes. In particular, the support arm **162** is pivotally secured to the upper surface **36** of the terminal base **34** by a pivot joint **166**, whereas the second support arm **164** is pivotally secured to the first support arm **162** by a pivot joint **168**.

The housing of the interactive customer interface terminal **78** is secured to an end portion of the second support arm **164**. In particular, the end portion of the second support arm **164** opposite the pivot joint **168** has a mounting structure **170** secured thereto. The housing of the interactive customer interface terminal **78** is bolted or otherwise fastened to the mounting structure **170** so as to secure the interactive customer interface terminal **78** to the support arm assembly **160**.

Such a configuration of the support arm assembly **160** allows the interactive customer interface terminal **78** to be moved relative to the terminal base **34** in a manner which maintains the display monitor **78b** at a relatively constant distance from the upper surface **34** of the terminal base. Moreover, such a configuration allows the interactive customer interface terminal **78** to be moved between a self-service position and an assisted position. In particular, as shown in FIGS. **1** and **19**, during operation of the checkout system **10** in its assisted mode of operation, the support arm assembly **160** is manipulated so as to cause the interactive customer interface terminal **78** to assume an assisted terminal position in which the display monitor **78a** faces the general direction of the payment area **16**. It should be appreciated that during an assisted checkout transaction, the customer is generally positioned in the proximity of the payment area **16**. Hence, by positioning the display monitor **78a** in the position shown in FIG. **19** (i.e. an assisted monitor position), retail information, along with other messages such as customer-specific advertisements, may be displayed on the display monitor **78a** for viewing by the customer while the checkout clerk enters the customer's items for purchase with the scanner **24**.

However, as shown in FIGS. **5** and **20**, during operation of the checkout system **10** in its self-service mode of operation, the support arm assembly **160** is manipulated so as to cause the interactive customer interface terminal **78** to assume a self-service terminal position in which the display monitor **78a** faces the general direction of the area located in front of the self-service bagwell **60**. It should be appreciated that during a self-service checkout transaction, the customer is generally positioned in the proximity of the area located in front of the bagwell **60** in order to scan items with the scanner **24** and thereafter place the items in grocery bags positioned in the self-service bagwell **60**. Hence, by positioning the display monitor **78a** in the position shown in FIG. **20** (i.e. a self-service monitor position), retail information such as transaction information (e.g. product prices and

descriptions), along with other messages such as instructional messages, may be displayed on the display monitor 78a for viewing by the customer while the customer enters his or her items for purchase with the scanner 24.

As shown in FIG. 1, the checkout system 10 also includes a status light device 84 and a paging device 86. The status light device 84 and the paging device 86 are provided in order to notify store personnel, such as a customer service manager, if intervention into the current checkout transaction is needed. In particular, if during operation of the checkout system 10, an intervention-needed activity is detected, the status light device 84 and the paging device 86 are operated so as to summon retail personnel such as a customer service manager. What is meant herein by the term "intervention-needed activity" is (1) activity by the customer or retail personnel in which the checkout system 10 is unintentionally operated improperly, (2) activity by the customer or retail personnel in which it can be inferred with a high degree of confidence that the checkout system 10 is intentionally operated improperly for illicit purposes such as theft, (3) activity by the customer or retail personnel in which the customer or retail personnel operates as input device associated with the checkout system 10 in a manner which indicates that he or she is in need of assistance, and (4) activity by the components associated with the checkout system 10 which has rendered the system in need of maintenance or other type of service.

Hence, an intervention-needed activity may take the form of a security-breach activity in which the checkout system 10 is being operated in a manner which is placing the retailer in a position of potential financial loss due to goods being taken from the store without having first been paid for (either intentionally or unintentionally), or a non-security-breach activity in which the customer or checkout clerk is in need of assistance or the checkout system 10 is in need of maintenance, but the retailer is not at risk of financial loss due to goods being taken from the store without having first been paid for. For example, if the customer attempted to scan an item a number of times with the scanner 24, but the product identification code associated with the item was not read by the scanner 24, the processing unit 78b concludes that an intervention-needed activity has occurred. Moreover, it should be appreciated that even if the product identification code associated with the item is entered, the processing unit 78b may determine that an intervention-needed activity has occurred. For example, if the customer scanned a first item, but then placed a second item of greater value into a grocery bag (as detected by, for example, the security scale 68), the processing unit 78b concludes that an intervention needed activity has occurred. For further example, if the customer or checkout clerk attempts to weigh an item such as produce with the product scale 26, but does not properly position the item on the product scale 26 or has not properly 'zeroed' the product scale 26, the processing unit 78b concludes that an intervention-needed activity has occurred.

Yet further examples of intervention-needed activities may include (1) failure to surrender an item after the item has been voided, (2) weighing only a portion of an item (i.e. weighing only one banana, but placing four bananas into a grocery bag), and (3) placing an item into a grocery bag or onto the set-aside shelf 70 without first attempting to scan or otherwise enter the item. Moreover, if the checkout clerk operating the system 10 touches a particular key on the keypad 76b associated with the personnel interface terminal 76 (see FIG. 23), or the customer touches a particular portion of the touch screen associated with the display monitor 78a, thereby indicating that he or she is in need of assistance, the

processing unit 78b concludes that an intervention-needed activity has occurred.

In addition, the processing unit 78b may monitor the status of the retail peripheral devices associated with the checkout system 10 in order to determine if an intervention-needed activity has occurred. For example, the processing unit 78b preferably monitors the currency level within the coin dispenser 48 and the bill dispenser 52 in order to determine if either currency dispenser 48, 52 is in need of restocking. Moreover, the processing unit 78b preferably monitors the paper supply level within the receipt printer 54 and a journal printer 88 (see FIG. 9) in order to determine if either printer 54, 88 is in need of restocking. It should be appreciated that if any one of the currency dispensers 48, 52 or the printers 54, 88 is in need of restocking, the processing unit 78b concludes that an intervention-needed activity has occurred.

It should be appreciated that although numerous examples of intervention-needed activities have herein been described, numerous other types of intervention-needed activities may exist, as defined by a particular retailer or provided by a particular design of the checkout system 10. Further examples of intervention-needed activities, along with a number of mechanisms and methods for detecting occurrence thereof, are disclosed in U.S. Pat. No. 5,952,642 entitled "Method and Apparatus for Detecting Item Substitutions During Entry of an Item into a Self-Service Checkout Terminal" by Dusty Lutz, which was issued on Sep. 14, 1999, and U.S. Pat. No. 5,747,784 entitled "Method and Apparatus for Providing Security for a Self-Service Checkout Station" by Joanne Walter and Tracy Flynn, which was issued on May 5, 1998; along with copending U.S. patent applications Ser. No. 081895,084 entitled "Method and Apparatus for Verifying Identity of an Item Being Checked Out Through a Retail Checkout Terminal" which was filed on Jul. 16, 1997, by Joanne Walter; Ser. No. 08/910,702 entitled "Method and Apparatus for Resetting a Product Scale of a Retail Checkout Terminal" which was filed on Aug. 13, 1997, by Dusty Lutz; Ser. No. 08/939,868 entitled "Method and Apparatus for Providing Security to a Self-Service Checkout Terminal" which was filed on Sep. 29, 1997, by John Addy and Jim Morrison; Ser. No. 081991,060 entitled "Method and Apparatus for Reducing Shrinkage During Operation of a Self-Service Checkout Terminal" which was filed on Dec. 15, 1997, by Jim Morrison and Joanne Walter; Ser. No. 08/990,241 entitled "Method and Apparatus for Detecting Item Placement and Item Removal During Operation of a Self-Service Checkout Terminal" which was filed on Dec. 15, 1997, by Jim Morrison and Dusty Lutz; Ser. No. 09/020,057 entitled "Method for Enhancing Security and Providing Assistance in the Operation of a Self-Service Checkout Terminal" which was filed on Feb. 06, 1998, by Ali Vassigh and Joanne Walter; Ser. No. 09/020,056 entitled "Self-Service Checkout Terminal" which was filed on Feb. 06, 1998, by Stephen Swaine, Ali Vassigh, and Grant Paton; and Ser. No. 09/019,880 entitled "Method of Enhancing Security in a Self-Service Checkout Terminal" which was filed on Feb. 06, 1998, by John Addy and Marc Lynn. The disclosures of each of the above-identified issued patents and patent applications are hereby incorporated by reference, and are assigned to the same assignee as the present invention.

As described above, once an intervention-needed activity has been detected, the status light device 84 is operated to summon retail personnel. For example, the status light device 84 may display a first colored light in order to notify retail personnel that intervention is needed prior to the end of

the current checkout transaction. Alternatively, the status light device **84** may display a second colored light in order to notify retail personnel that intervention is needed immediately.

As with the status light device **84**, the paging device **86** is utilized to page or otherwise summon retail personnel to the checkout system **10** once an intervention-needed activity has been detected. The paging device **86** is particularly useful since, it is operable to communicate with retail personnel who may be positioned at locations within or outside of the store which are out of the view of the status light device **84**. In particular, the paging device **86** includes a signal transmitter **86a** which may include any one of numerous known signal transmitters or transceivers such as a radio frequency (RF) signal transmitter. One such signal transmitter which is particularly useful as the signal transmitter **86a** of the present invention is a model number 1200B Transmitter which is commercially available from Scope, Incorporated of Great Britain.

As shown in FIG. **22**, the signal transmitter **86a** is configured to communicate with a number of portable communication devices such as wireless alphanumeric pagers **90**. In particular, the signal transmitter **86a** is configured to communicate to the pagers **90** at a predetermined frequency (e.g. 450 MHz) in order to transmit alphanumeric messages to retail personnel wearing the pagers **90**. Hence, upon detection of an intervention-needed activity by the processing unit **78b**, an intervention-needed control signal is generated. Generation of an intervention-needed control signal causes the signal transmitter **86a** to generate an RF personnel-request signal which is received by the pagers **90**. The personnel-request signal includes a specific alphanumeric message that includes such information as the nature of the intervention which is needed and the identity of the particular checkout system **10** which requires assistance. For example, if one of the currency dispensers **48, 52** needs to be restocked, the signal transmitter **86a** generates an RF personnel-request signal which causes a message to be displayed on one of the pagers **90** which informs the customer service manager wearing the pager **90** that a particular checkout system **10** is, for example, running low on dimes.

Moreover, as shown in FIG. **22**, the signal transmitter **86a** is configured to communicate with an audible message generating device such as an intercom device **92** having an RF signal receiver **92a**, a number of speakers **92b**, and a controller **92c** associated therewith. The speakers **92b** associated with the intercom device **92** are located within the ceilings or other locations throughout the retailer's store. The signal transmitter **86a** of the paging device **86** is also configured to communicate with the signal receiver **92a** associated with the intercom device **92** at a predetermined frequency (e.g. 450 MHz) in order to generate audible messages which are broadcast to retail personnel within the store with the speakers **92b**. In particular, upon detection of an intervention-needed activity by the processing unit **78b**, an intervention-needed control signal is generated. Generation of an intervention-needed control signal causes the signal transmitter **86a** to generate an RF personnel-request signal which is received by the signal receiver **92a** associated with the intercom device **92**. The personnel-request signal includes a specific code which corresponds to a number of specific, prerecorded audible messages stored in, or otherwise maintained by, the controller **92c** of the intercom device **92**. For example, each of the prerecorded messages may include such information as the nature of the intervention which is needed and the identity of the particular checkout system **10** which requires assistance. The controller **92c** causes such

prerecorded audible messages to be broadcast with the speakers **92b** so as to be audibly detected by retail personnel such as a customer service manager within the retailer's store. For example, if one of the currency dispensers **48, 52** needs to be restocked, the signal transmitter **86a** generates an RF personnel-request signal which, once received by the signal receiver **92a**, causes an audible message to be broadcast on the speakers **92b** which informs the customer service manager that a particular checkout system **10** is, for example, running low on dimes.

It should be appreciated that use of the signal transmitter **86a** in conjunction with the intercom device **92** provides the checkout system **10** of the present invention with numerous advantages over heretofore designed checkout systems. For example, a number of retail stores currently include an intercom device similar to the intercom device **92** of the present invention. In particular, intercom devices having a controller for playing a number of specific, prerecorded messages are installed in a number of retail stores. However, in order to broadcast a specific message with the speakers associated with the intercom device, the specific code corresponding to the audible message must be manually entered by retail personnel or the customer by use of a dedicated keypad or the like. Hence, by providing for the input of the specific codes corresponding to the various audible messages by use of the signal transmitter **86a** and the signal receiver **92a**, the checkout system **10** itself can actuate the intercom device **92** without manual entry of the specific code by the customer or retail personnel. Utilization and/or retrofit of an existing intercom device reduces the costs associated with implementation of the checkout system **10** thereby increasing the appeal of the system **10** to retailers.

The RF transmitter **86a** of the paging device **86** has a broadcast antenna **86b** associated therewith. The broadcast antenna **86b** is secured to a support structure associated with the status light device **84**. In particular, as shown in FIG. **1**, the status light device **84** includes a lamp assembly **84a** secured atop a pole **84b**. The broadcast antenna **86b** is fastened or otherwise secured to the pole **84b**. Alternatively, the pole **84b** may be constructed of a material which would allow the pole **84b** itself to function as the broadcast antenna **86b**. It should be appreciated that securing the broadcast antenna **86b** to the pole **84b** (or integrating the antenna **86b** with the pole **84b**, as described above) provides numerous advantages. For example, by securing the broadcast antenna **86b** to the pole **84b**, a relatively long antenna may be utilized without the risk of the antenna **86b** being accidentally damaged by, for example, retail personnel or the customer. It should be appreciated that utilization of a relatively long antenna is useful for increasing the transmission range of the RF transmitter **86a**.

The checkout system **10** also has a video system **94**. The video system **94** includes a video camera such as a digital video camera **94a** (see FIG. **1**). The video system is included to provide security during operation of the checkout system **10**. In particular, at the commencement of a checkout transaction, the video camera **94a** is operated so as to capture a video image of the user (e.g. the customer or the checkout clerk) who is operating the checkout system **10**. In a known manner, the captured video image of the customer is then stored in an electronic video file by the processing unit **78b**. A subsequent video image (which is representative of the captured video image) may then be extracted from the electronic video file for use by the checkout system **10**. For example, in the case of when the checkout system **10** is being operated in the self-service mode of operation, the extracted video image of the customer may be displayed on a

portion of the display monitor 78a associated with the interactive customer interface terminal 78. Hence, as the customer is entering his or her items for purchase with the scanner 24, a video image of himself or herself is displayed on the display monitor 78a. It should be appreciated that displaying a video image of the customer serves as a psychological deterrent to the customer in regard to the commission of an impropriety such as theft. In particular, the customer is less likely to commit an impropriety such as theft once the customer realizes that the checkout system 10 has captured a video image himself or herself. Similarly, a video image of the checkout clerk could be displayed on the display monitor 76a of the personnel interface terminal 76 in order to serve as a psychological deterrent to the checkout clerk against "sweethearting" or other improprieties.

Moreover, in the case of when the checkout system 10 is being operated in its self-service mode of operation, the extracted video image of the customer may be printed with the receipt printer 54. In particular, once the customer has tendered payment for his or her items for purchase, a transaction receipt 96 is printed for the customer with the receipt printer 54. As shown in FIG. 14, the transaction receipt 96 printed by the receipt printer 54 preferably includes transaction information 96a associated with the customer's checkout transaction such as a list including the description and price of each item purchased along with the total cost of the transaction. Moreover, a rendition of the extracted video image 96b of the customer is also printed on the bottom portion of the transaction receipt. Hence, as the customer is entering his or her items for purchase with the scanner 24, a video image of the customer is captured and then later printed on the bottom portion of the customer's transaction receipt 96. It should be appreciated that printing an image of the customer serves as a psychological deterrent to the customer in regard to the commission of an impropriety such as theft. In particular, the customer is less likely to commit an impropriety such as theft once the customer realizes that the checkout system 10 has captured a video image himself or herself. Similarly, a video image of the checkout clerk could be printed with the receipt printer 54 in order to serve as a psychological deterrent against "sweethearting" or other improprieties.

Moreover, the video system 94 may be utilized to capture and thereafter store video images associated with other portions of the checkout system 10. For example, the video camera 94a of the video system 94 may be utilized to capture video images associated with one or more of the grocery bags within the bagwells 60, 62. The video images associated with the grocery bags may then be displayed on the display monitor 78a. Displaying the contents of the customer's grocery bag also serves as a psychological deterrent to the customer since the customer is less likely to insert unscanned or otherwise unentered items (or substituted items) once the customer realizes that the checkout system 10 has captured a video image or the customer's grocery bags.

Yet further, the video system 94 may be utilized to capture and thereafter store video images associated with a shopping receptacle in order to reduce the number of items which are intentionally or unintentionally taken from the retailer's store without having first been entered into the checkout system 10 (and hence paid for). In particular, as shown in FIG. 16, the video camera 94a of the video system 94 may be utilized to capture a video image of a shopping cart 238 or a shopping basket 240. In a known manner, the captured video image of the shopping cart 238 or shopping basket 240 is then stored in an electronic video file by the processing unit 78b.

The electronic video file of the shopping cart 238 or shopping basket 240 is then compared to a reference electronic video file in order to determine if the shopping cart 238 or shopping basket 240 is devoid of items (i.e. empty). In particular, a reference video image of an empty shopping cart or shopping basket is stored as a reference electronic video file in either a local memory device associated with the checkout system (e.g. memory modules or a hard drive) or on a network memory device associated with the retailer's network. In any event, the electronic video file associated with the captured image of the shopping cart 238 or shopping basket 240 is compared to the reference electronic video file associated with an empty shopping cart or shopping basket. If the electronic video file associated with the captured image of the shopping cart 238 or shopping basket 240 matches the reference electronic video file associated with an empty shopping cart or shopping basket, then the checkout system 10 concludes that the customer's shopping cart 238 or shopping basket 240 is devoid of items (i.e. empty). However, if the electronic video file associated with the captured image of the shopping cart 238 or shopping basket 240 does not match the reference electronic video file associated with an empty shopping cart or shopping basket, then the checkout system 10 concludes that the customer's shopping cart 238 or shopping basket 240 has items remaining therein.

What is meant herein by the terms "match", "matches", or "matching" in regard to electronic video files is that a first electronic video file is determined to be the same as or within a predetermined tolerance range of a second electronic video file. Hence, the electronic video files associated with the captured images of the shopping cart 238 or shopping basket 240 match the respective reference electronic video file if they are determined to be the same or within a predetermined tolerance range of the reference electronic video file associated with an empty shopping cart or shopping basket.

Referring now to FIG. 9, there is shown a simplified block diagram of the checkout system 10. In addition to the display monitor 78a, the processing unit 78b of the interactive customer interface terminal 78 is electrically coupled to the scanner 24, the product scale 26, the electronic payment terminal 44, the coin acceptor 46, the bill acceptor 50, the coin dispenser 48, the bill dispenser 52, the receipt printer 54, the security scale 68, the personnel interface terminal 76, the status light device 84, the paging device 86, the journal printer 88, the item sensors 98, 100, the input belt mechanism 20, and the security deactivation device 172. The processing unit 78b is also electrically coupled to a signature capture device 102, a lane light 104, and a supervisor switch 106.

The processing unit 78b monitors output signals generated by the assembly of the scanner 24 and product scale 26 via a serial data communication line 114 (e.g. an RS-232 serial data cable). In particular, when the customer scans an item which includes a product identification code across the scanning windows 24a, 24b, an output signal indicative of the product identification code is generated on the data communication line 114. Similarly, when a customer places an item on the product scale 26, the product scale 26 generates an output signal on the data communication line 114 which is indicative of the weight of the item.

The processing unit 78b is electrically coupled to the digital video camera 94a via a parallel data communication line 116 (e.g. a parallel data cable). The processing unit 78b generates control signals on the communication line 116 which cause the digital video camera 94a to capture video images

of the customer, the checkout clerk, a portion of the checkout system **10**, the shopping cart **238** or basket **240**, etcetera, in order to enhance security during operation of the system **10**. A data stream representative of such captured video images is then communicated to the processing unit **78b** via the communication line **116** for processing thereof. In particular, such captured video images may be stored in the memory devices associated with the processing unit **78b** for future use by, as described above, printing a rendition of a captured video image of the customer on the customer's transaction receipt **96** (see FIG. **14**) or displaying a video image of the customer or the customer's grocery bags on the display monitors **78a** or **76a**.

The checkout system **10** also includes a number of port expander devices **108**, **110**. The port expander devices **108**, **110** may be any known port expander device which enables a number of communication lines (e.g. data cables) to be connected to a single port of a controller (e.g. the connector ports associated with the interactive customer interface terminal **78**). Moreover, the port expander devices **108**, **110** of the present invention preferably allow more than one interface type. For example, the port expander devices **108**, **110** of the present invention are preferably coupled to the processing unit **78b** of the interactive customer interface terminal **78** via a Universal Serial Bus (USB) interface, but are coupled to certain retail peripheral devices (e.g. the electronic payment terminal **44**, the cash dispenser **52**, or the security scale **68**) via an RS-232 serial interface. Such a configuration is particularly useful since commercially available retail devices are typically configured to communicate with a controller via an RS-232 serial interface thereby allowing the checkout system **10** to be configured with "industry standard" retail peripheral devices as opposed to more expensive, proprietary devices. It should be appreciated that in addition to USB/RS-232 port expander devices, other types of port expander devices may also be utilized in the present invention. For example, port expander devices which are coupled to the processing unit **78b** via an Ethernet interface (i.e. an Ethernet/RS-232 port expander device) may also be utilized in the present invention.

As utilized in construction of the checkout system **10**, the port expander devices **108**, **110** facilitate the coupling of a number of retail peripheral devices associated with the system **10** to the processing unit **78b** of the interactive customer interface terminal **78**. In particular, a USB port **110a** of the port expander device **110** is coupled to a first USB data port **78e** of the processing unit **78b** via a USB communication line **112** (e.g. a USB data cable).

A serial port **54a** of the receipt printer **54** is coupled to a first serial port **110b** of the port expander device **110** via a serial communication line **118** (e.g. an RS-232 serial data cable). Hence, the processing unit **78b** communicates with the receipt printer **54** via a data path that includes the USB communication line **112**, the port expander device **110**, and the serial communication line **118**. In such a manner, the processing unit **78b** communicates with the receipt printer **54** in order to generate transaction receipts at the completion of a checkout transaction. The receipt printer **54** may be embodied as any type of ink-jet, laser, dot-matrix, LED, or thermal printer which is capable of printing the alphanumeric characters associated with transaction information **96a** on the transaction receipt **96** (see FIG. **14**), along with certain graphical representations associated with the rendition of the extracted video image **96b** of the customer (see FIG. **14**) when the checkout system **10** is configured to print such a rendition on the transaction receipt **96**.

A serial port **44a** of the electronic payment terminal **44** is coupled to a second serial port **110c** of the port expander

device **110** via a serial communication line **120** (e.g. an RS-232 serial data cable). Hence, the processing unit **78b** communicates with the electronic payment terminal **44** via a data path that includes the USB communication line **112**, the port expander device **110**, and the serial communication line **120**. In such a manner, the processing unit **78b** communicates with the electronic payment terminal **44** in order to allow a customer to electronically tender payment for his or her items for purchase via, for example, a debit, credit, or smart card. In particular, as described above, the electronic payment terminal **44** includes a card reader and an input device such as a keypad. The keypad associated with the electronic payment terminal **44** may include one or more of a known keypad or a touch pad, whereas the card reader may include a known credit, debit, loyalty, and/or smart card reader which is capable of reading information stored on the customer's card. Hence, the processing unit **78b** communicates with the electronic payment terminal in order to receive data read from the customer's card or codes such as PIN numbers which are input by the customer via use of the keypad.

A serial port **68a** of the security scale **68** is coupled to a third serial port **110d** of the port expander device **110** via a serial communication line **122** (e.g. an RS-232 serial data cable). Hence, the processing unit **78b** communicates with the security scale **68** via a data path that includes the USB communication line **112**, the port expander device **110**, and the serial communication line **122**. In such a manner, the processing unit **78b** communicates with the security scale **68** in order to (1) monitor the placement of items into, or the removal of items from, the self-service bagwell **60** and the assisted bagwell **62**, and (2) the placement of items onto, and the removal of items off of, the set-aside shelf **70**. In particular, when an item is placed into one of the grocery bags within the bagwells **60**, **62** or onto the set-aside shelf **70**, the security scale **68** generates an output signal indicative of the weight of the item which is communicated to the processing unit **78b**. Similarly, when an item is removed from one of the grocery bags within the bagwells **60**, **62** or from the set-aside shelf **70**, the security scale **68** generates an output signal indicative of the weight of the removed item which is communicated to the processing unit **78b**.

A serial port **102a** of the signature capture device **102** is coupled to a fourth serial port **110e** of the port expander device **110** via a serial communication line **124** (e.g. an RS-232 serial data cable). Hence, the processing unit **78b** communicates with the signature capture device **102** via a data path that includes the USB communication line **112**, the port expander device **110**, and the serial communication line **124**. In such a manner, the processing unit **78b** communicates with the signature capture device **102** in order to create an electronic record of a customer's signature during a credit transaction. In particular, the signature capture device **102** may include any known signature capture device which is capable of generating an electronic representation of a customer's signature when the customer signs his or her name with a pen, stylus, or other writing instrument associated with the signature capture device **102**. Capturing a customer's signature with a signature capture device **102** generally causes the retailer to be charged a smaller transaction fee for the credit card transaction from the bank or other financial institution which issued the customer's card. Such lower transaction fees are particularly beneficial in the retail grocery business due to the relatively small profit margins associated with such a business.

A serial port **86c** of the paging device **86** is coupled to a fifth serial port **110f** of the port expander device **110** via a

serial communication line 126 (e.g. an RS-232 serial data cable). Hence, the processing unit 78b communicates with the paging device 86 via a data path that includes the USB communication line 112, the port expander device 110, and the serial communication line 126. In such a manner, the processing unit 78b communicates with the paging device 86 in order to generate RF signals which are received by either the wireless alphanumeric pagers 90 or the RF signal receiver 92 associated with the store's intercom device 92. As described above, such RF communications allows retail personnel to be summoned to the checkout system 10 in order to provide assistance and/or security during operation of the checkout system 10.

A serial port 88a of the journal printer 88 is coupled to a sixth serial port 110g of the port expander device 110 via a serial communication line 128 (e.g. an RS-232 serial data cable). Hence, the processing unit 78b communicates with the journal printer 88 via a data path that includes the USB communication line 112, the port expander device 110, and the serial communication line 128. In such a manner, the processing unit 78b communicates with the journal printer 88 in order to generate a journal or printer record of each checkout transaction performed by the checkout system 10. The journal printer 88 may be embodied as any type of ink-jet, laser, dot-matrix, LED, or thermal printer which is capable of printing a record of the checkout transactions performed on the system 10. Preferably, the journal printer 88 is configured to print such a record on "roll-type" paper so as to facilitate collection of the record.

A serial port 172a of the security deactivation device 172 is coupled to a seventh serial port 110h of the port expander device 110 via a serial communication line 174 (e.g. an RS-232 serial data cable). Hence, the processing unit 78b communicates with the security deactivation device 172 via a data path that includes the USB communication line 112, the port expander device 110, and the serial communication line 174. In such a manner, the processing unit 78b communicates with the security deactivation device 172 in order to generate a deactivation field (e.g. a magnetic or electromagnetic field) which deactivates electronic security tags associated with an EAS system. As described above, the security deactivation device 172 may be configured to continuously generate a deactivation field, or alternatively, the processing unit 78b may communicate with the security deactivation device 172 to selectively generate the deactivation field in response to capture of the product code associated with an item being scanned or otherwise entered into the checkout system 10.

Similarly to the port expander device 110, the port expander device 108 is utilized to facilitate communication between the processing unit 78b and a number of retail peripheral devices. In particular, a USB port 108a of the port expander device 108 is coupled to a second USB data port 78f of the processing unit 78b via a USB communication line 138 (e.g. a USB data cable).

A serial port 48a of the coin dispenser 48 is coupled to a first serial port 108b of the port expander device 108 via a serial communication line 130 (e.g. an RS-232 serial data cable). Hence, the processing unit 78b communicates with the coin dispenser 48 via a data path that includes the USB communication line 138, the port expander device 108, and the serial communication line 130. In such a manner, the processing unit 78b communicates with the coin dispenser 48 in order to dispense change in the form of coins to a customer during finalization of a checkout transaction. In particular, when a customer is owed change in the form of coins during finalization of a checkout transaction, the pro-

cessing unit 78b generates an output signal indicative of the amount of change in the form of coins that is owed the customer. Such an output signal is communicated to the coin dispenser 48 thereby causing the coin dispenser 48 to dispense the correct amount of change in the form of coins to the customer.

A serial port 46a of the coin acceptor 46 is coupled to a second serial port 108c of the port expander device 108 via a serial communication line 132 (e.g. an RS-232 serial data cable). Hence, the processing unit 78b communicates with the coin acceptor 46 via a data path that includes the USB communication line 138, the port expander device 108, and the serial communication line 132. In such a manner, the processing unit 78b communicates with the coin acceptor 46 in order to accept coins from a customer during finalization of a checkout transaction. In particular, when a customer inserts coins into the coin acceptor 46 during finalization of a checkout transaction, the coin acceptor 46 generates an output signal indicative of the value of each coin which is inserted into the coin acceptor 46. Such an output signal is communicated to the processing unit 78b in order to determine if the customer has inserted the requisite amount of currency to tender payment for his or her items for purchase.

A serial port 52a of the bill dispenser 52 is coupled to a third serial port 108d of the port expander device 108 via a serial communication line 134 (e.g. an RS-232 serial data cable). Hence, the processing unit 78b communicates with the bill dispenser 52 via a data path that includes the USB communication line 138, the port expander device 108, and the serial communication line 134. In such a manner, the processing unit 78b communicates with the bill dispenser 52 in order to dispense change in the form of bills to a customer during finalization of a checkout transaction. In particular, when a customer is owed change in the form of bills during finalization of a checkout transaction, the processing unit 78b generates an output signal indicative of the amount of change in the form of bills that is owed the customer. Such an output signal is communicated to the bill dispenser 52 thereby causing the bill dispenser 52 to dispense the correct amount of change in the form of bills to the customer.

A serial port 50a of the bill acceptor 50 is coupled to a fourth serial port 108e of the port expander device 108 via a serial communication line 136 (e.g. an RS-232 serial data cable). Hence, the processing unit 78b communicates with the bill acceptor 50 via a data path that includes the USB communication line 138, the port expander device 108, and the serial communication line 136. In such a manner, the processing unit 78b communicates with the bill acceptor 50 in order to accept bills from a customer during finalization of a checkout transaction. In particular, when a customer inserts bills into the bill acceptor 50 during finalization of a checkout transaction, the bill acceptor 50 generates an output signal indicative of the value of each bill that is inserted into the bill acceptor 50. Such an output signal is communicated to the processing unit 78b in order to determine if the customer has inserted the requisite amount of currency to tender payment for his or her items for purchase.

It should be appreciated that use of the port expander devices 108, 110 provides the checkout system 10 of the present invention with numerous advantages over heretofore checkout systems. For example, use of the port expander devices 108, 110 allows the processing unit 78b associated with the interactive customer interface terminal 78 to be configured with a relatively small number of output connectors. For example, if not for use of the port expander devices 108, 110, a connector would have to be provided on the processing unit 78b for each of the components which are coupled



to the port expander devices **108**, **110** in FIG. **9** in order to couple the components directly to the output connectors of the processing unit **78b**. Such a requirement for additional connector/port capacity would undesirably increase the size and cost of the interactive customer interface terminal **78**.

In addition to reducing the number of output connectors that must be provided on the processing unit **78b**, use of the port expander devices **108**, **110** also simplifies or otherwise enhances the cable management of the checkout system **10**. In particular, the port expander devices **108**, **110** are preferably located in relatively close proximity to the retail peripheral devices to which port expander devices **108**, **110** are coupled thereby reducing the distance across which the individual serial cables associated with each peripheral device must be routed. For instance, it is preferable to mount the port expander device **108**, **110** within the same terminal cabinet **28**, **30**, **32** in which the retail peripheral devices coupled to the port expander devices **108**, **110** are disposed.

In a specific example, as shown in FIGS. **1** and **9**, the port expander device **108** is secured within the terminal cabinet **32** so as to be located in relatively close proximity to the coin dispenser **48**, the coin acceptor **46**, the bill dispenser **52**, and the bill acceptor **50**. In such a configuration, the serial cables respectively associated with each of the currency devices **46**, **48**, **50**, **52** (i.e. the serial communication lines **130**, **132**, **134**, **136**, respectively) are completely contained within the terminal cabinet **32**. What is meant herein by the term “completely contained” in regard to cables is that the entire cable is positioned within a structure (e.g. one of the terminal cabinets **28**, **30**, **32**) such that no portion of cable extends out of the structure. Hence, in regard to the port expander device **108**, only the USB cable (i.e. the USB communication line **138**) must be routed outside of the terminal cabinet **32**. In particular, a first end connector of the cable associated with the USB communication line **138** is secured to the second USB port **78f** of the processing unit **78b**, whereas a second end connector of the cable associated with the USB communication line **138** is secured to the USB port **108a** of the port expander device **108**. Hence, a central portion of the cable associated with the USB communication line **138** is routed or otherwise extends between the terminal cabinet **30** and the terminal cabinet **32**. However, the USB cable associated with the USB communication line **138** is the only cable associated with the currency devices **46**, **48**, **50**, **52** that extends out of the terminal cabinet **32**.

It should be appreciated that the port expander device **110** may be positioned in a similar manner. For example, the port expander device **110** may be positioned within the terminal cabinet **30** in order to be located in relatively close proximity to the retail peripheral devices to which the port expander device **110** is coupled (e.g. the security scale **68** or the electronic payment device **44**).

Moreover, it should also be appreciated that any number of port expander devices, or configurations thereof, may be utilized in conjunction with the concepts of the present invention in order to provide for use of additional retail peripheral devices or to further enhance the cable management of the checkout system **10**. For example, although the assembly of the scanner **24** and the product scale **26** is shown in FIG. **9** and described herein as being directly coupled to a serial port of the processing unit **78b**, the assembly of the scanner **24** and the product scale **26** could alternatively be coupled to an available serial port associated with the port expander device **110** thereby eliminating the need to route the serial cable associated with the assembly of the scanner **24** and the product scale **26** (i.e. the serial communication line **114**) all the way back to the processing unit **78b**.

The processing unit **78b** of the interactive customer interface terminal **78** also controls operation of a number of components associated with the checkout system **10** which are not controlled via use of a standard communication protocol (e.g. RS-232). In particular, a number of components associated with the checkout system **10** are “on-off” devices such as the lane light **104**, the lamp assembly **84a** associated with the status light device **84**, and the motor (not shown) associated with the input belt mechanism **20**. The checkout system **10** further includes an interface unit **140** for interfacing with such devices. In particular, the interface unit **140** interfaces with the input belt mechanism **20**, the lamp assembly **84a** of the status light device **84**, the item sensors **98**, **100**, the lane light **104**, and the supervisor switch **106**. As shown in FIG. **9**, the interface unit **140** is coupled to a serial port associated with the processing unit **78b** via a serial communication line **142** (e.g. a serial cable).

The input belt mechanism **20** is coupled to the interface unit **140** via a control line **144**. Hence, the processing unit **78b** controls operation of the input belt mechanism **20** via a data path that includes the serial communication line **142**, the interface unit **140**, and the control line **144**. In such a manner, the processing unit **78b** controls actuation of the motor (not shown) associated with the input belt mechanism **20** so as to control advancement of the input belt **22**. In particular, as described above, the input belt mechanism **20** may be actuated when placement of an item onto the input belt **22** is detected by the upstream item sensor **98** thereby causing the item to be moved in a downstream direction toward the scanner **24**. Thereafter, the input belt mechanism **20** is deactivated when arrival of the item at a predetermined location at the downstream end portion **22b** of the input belt **22** is detected by the downstream item sensor **100**. Moreover, advancement of the input belt **22** may be manually controlled by retail personnel or a customer via use of the key pad associated with the personnel interface terminal **76** (in the case of control by retail personnel) or the touch screen associated with the display monitor **78a** of the interactive customer interface terminal **78** (in the case of control by the customer). In the case of such manual advancement of the input belt **22**, the processing unit **78b** selectively generates output signals which selectively cause actuation and deactuation of the input belt mechanism **20**.

The input belt mechanism **20** is coupled to the interface unit **140** via a control line **144**. Hence, the processing unit **78b** controls operation of the input belt mechanism **20** via a data path that includes the serial communication line **142**, the interface unit **140**, and the control line **144**. In such a manner, the processing unit **78b** controls actuation of the motor (not shown) associated with the input belt mechanism **20** so as to control advancement of the input belt **22**. In particular, as described above, the input belt mechanism **20** may be actuated when placement of an item onto the input belt **22** is detected by the upstream item sensor **98** thereby causing the item to be moved in a downstream direction toward the scanner **24**. Thereafter, the input belt mechanism **20** is deactivated when arrival of the item at a predetermined location at the downstream end portion **22b** of the input belt **22** is detected by the downstream item sensor **100**. Moreover, advancement of the input belt **22** may be manually controlled by retail personnel or a customer via use of the key pad associated with the personnel interface terminal **76** (in the case of control by retail personnel) or the touch screen associated with the display monitor **78a** of the interactive customer interface terminal **78** (in the case of control by the customer). In the case of such manual advancement of the input belt **22**, the processing unit **78b** selectively gener-

ates output signals which selectively cause actuation and deactuation of the input belt mechanism 20.

The lamp assembly 84a of the status light device 84 is coupled to the interface unit 140 via a control line 146. Hence, the processing unit 78b controls operation of the input belt mechanism 20 via a data path that includes the serial communication line 142, the interface unit 140, and the control line 146. In such a manner, the processing unit 78b controls actuation of the lamps associated with the lamp assembly 84a. In particular, as described above, the lamp assembly 84a is utilized to summon retail personnel to the checkout system 10 in order to provide assistance and/or security during operation of the system 10. Accordingly, the processing unit 78b may cause a red lamp associated with the lamp assembly 84a to be illuminated when intervention by retail personnel is needed immediately, whereas a yellow lamp may be illuminated when intervention is not needed until the end of the customer's transaction. Similarly, a green lamp may be illuminated when the checkout system 10 is being operated properly without the need for intervention by retail personnel.

The upstream item sensor 98 is coupled to the interface unit 140 via a signal line 148. Hence, the processing unit 78b communicates with the upstream item sensor 98 via a data path that includes the serial communication line 142, the interface unit 140, and the signal line 148. In such a manner, the processing unit 78b determines when the customer places an item for purchase on the input belt 22. In particular, as described above, the upstream item sensor 98 is preferably embodied as a photodetector device which generates a light beam which is emitted across the upstream end portion 22a of the input belt 22. The upstream item sensor 98 generates an output signal which is sent to the processing unit 78b when the light beam is interrupted by an item being placed on the input belt 22 by a customer.

The downstream item sensor 100 is coupled to the interface unit 140 via a signal line 150. Hence, the processing unit 78b communicates with the downstream item sensor 100 via a data path that includes the serial communication line 142, the interface unit 140, and the signal line 150. In such a manner, the processing unit 78b determines when an item that is being advanced toward the scanner 24 by the input belt mechanism 22 has been advanced to a predetermined location on the downstream end portion 22b of the input belt 22. In particular, as described above, the downstream item sensor 98 is preferably embodied as a photodetector device which generates a light beam which is emitted across the downstream end portion 22b of the input belt 22. The downstream item sensor 100 generates an output signal which is sent to the processing unit 78b when the light beam is interrupted by an item being advanced on the input belt 22 once the item has been advanced to the predetermined location on the downstream end portion 22b of the input belt 22.

The lane light 104 is coupled to the interface unit 140 via a control line 152. Hence, the processing unit 78b controls operation of the lane light 104 via a data path that includes the serial communication line 142, the interface unit 140, and the control line 152. In such a manner, the processing unit 78b controls actuation of the lamps associated with the lane light 104. The lane light 104 is utilized to communicate the lane number associated with a given checkout system 10 to retail personnel or customers. In particular, when a particular lamp associated with the lane light 104 is illuminated, the lane number associated with the given checkout system 10 is displayed. Such illumination also communicates that the checkout system 10 is "open" (i.e. available for use by the customer). Moreover, the lane light 104 is also config-

ured to have lamp assemblies which, when illuminated, display a message such as "SELF-SERVICE" if the checkout system 10 is configured in its self-service mode of operation, or alternatively, to display a message such as "ASSISTED" or "FULL-SERVICED" if the checkout system 10 is configured in its assisted mode of operation.

The supervisor switch 106 is coupled to the interface unit 140 via a signal line 154. Hence, the processing unit 78b monitors output from the supervisor switch 106 via a data path that includes the serial communication line 142, the interface unit 140, and the signal line 154. In such a manner, the processing unit 78b determines whether to operate the checkout system 10 in its self-service mode of operation or its assisted mode of operation. In particular, retail personnel such as a customer service manager toggles the supervisor switch 106 during a changeover procedure associated with changing the checkout system 10 between its self-service mode of operation and its assisted mode of operation. It should be appreciated that the operating system software executed by the processing unit 78b may have certain features which are selectively enabled or disabled based on whether the checkout system 10 is being operated in its self-service mode of operation or its assisted mode of operation.

The processing unit 78b communicates with the personnel interface terminal 76 through a data communication line 156 (i.e. a data cable). The processing unit 78b generates output signals on the data communication line 156 which cause instructional messages and transaction information to be displayed on the display monitor 76a (see FIG. 23) of the personnel interface terminal 76. Moreover, data signals generated by the keypad 76b associated with the personnel interface terminal 76 are transmitted to the processing unit 78b via the communication line 156 when retail personnel touches a particular key associated with the keypad 76b.

The processing unit 78b communicates with the display monitor 78a associated with the interactive customer interface terminal 78 through an internal data bus 158. The processing unit 78b generates output signals on the data bus 158 which cause various messages such as transaction information, instructions, or advertisements to be displayed on the display monitor 78a. As alluded to above, the display monitor 78a may include known touch screen technology which can generate output signals when the customer touches a particular area of the display screen associated with the display monitor 78a. The signals generated by the display monitor 78a are transmitted to the processing unit 78b via the data bus 158.

The processing unit 78b may also be utilized to control additional system components associated with various configurations of the checkout system 10. For example, the motor (not shown) associated with the takeaway belt mechanism 56 may be controlled by the processing unit 78b in a similar manner similar to the motor (not shown) associated with the input belt mechanism 20. In particular, the takeaway belt mechanism 56 is coupled to the interface unit 140 via a control line 176. Hence, the processing unit 78b controls operation of the takeaway belt mechanism 56 via a data path that includes the serial communication line 142, the interface unit 140, and the control line 176. In such a manner, the processing unit 78b controls actuation of the motor (not shown) associated with the takeaway belt mechanism 56 so as to control advancement of the takeaway belt 58. In particular, as described above, the takeaway belt mechanism 56 may be actuated in order to advance items which have been scanned or otherwise entered from the itemization area 14 to the bagging counter 66.

Moreover, the payment area 16 of the checkout system 10 may be configured with a coupon acceptor 178 (see FIGS. 1,

5, and 9). The coupon acceptor 178 is provided to allow a customer to tender coupons, vouchers, or the like during operation of the checkout system 10. As shown in FIG. 9, a serial port 178a of the coupon acceptor 178 is coupled to a fifth serial port 108f of the port expander device 108 via a serial communication line 180 (e.g. an RS-232 serial data cable). Hence, the processing unit 78b communicates with the coupon acceptor 178 via a data path that includes the USB communication line 138, the port expander device 108, and the serial communication line 180. In such a manner, the processing unit 78b communicates with the coupon acceptor 178 in order to accept coupons from a customer during finalization of a checkout transaction. In particular, when a customer inserts coupons into the coupon acceptor 178 during finalization of a checkout transaction, the coupon acceptor 178 generates an output signal indicative of the presence of the tendered coupon. Such an output signal is communicated to the processing unit 78b in order to confirm that the coupon has been tendered. It should be appreciated that the coupon acceptor 178 may be equipped with a bar code reader or the like to capture machine readable indicia that is printed on certain coupons.

Moreover, the checkout system 10 may also be configured to include a cash drawer for allowing the checkout clerk to receive payment from the customer. In such a configuration, the cash drawer would also be under control of the processing unit 78b such that the solenoids and the like utilized to open the cash drawer are actuated by control signals from the processing unit 78b.

The processing unit 78b includes network circuitry (not shown) which conventionally permits the checkout system 10 to communicate with the retailer's network 184 such as a LAN or WAN through a wired connection 182 (see FIG. 9). The processing unit 78b communicates with the retailer's network 184 during the checkout procedure in order to obtain information, such as pricing information, associated with an item being scanned or otherwise entered, and also to verify customer credit approval when appropriate. The network interface circuitry associated with the checkout system 10 may include a known Ethernet expansion card, and the wired connection 182 may include a known twisted-pair communication line. Alternatively, the network interface circuitry may support wireless communications with the retailer's network 184.

The processing unit 78b also communicates with the retailer's network 184 in order to access a customer profile database maintained in a network memory device such as a network mass storage device (not shown) associated with a network central server (not shown). The customer profile database includes unique, customer-specific retail information associated with each of the retailer's customers. For example, when a customer initially applies or otherwise registers for his or her loyalty card, customer-specific retail information such as name, address, gender, age, account numbers, or other demographic information is generally collected on the customer's application. Such customer-specific retail information is included in the customer's profile within the customer profile database. Moreover, the customer's profile within the customer profile database may also include customer-specific retail information such as the customers shopping or purchasing history. For example, a record of the items purchased during recent visits to the retailer's store may be included in the customers profile. Moreover, a record may also be made to the customers profile if the customer redeems a certain type of voucher or coupons or responds to a certain type of promotion.

As discussed above, contents of the customer profile database are utilized in order to generate customer-specific mes-

sages to the customer during a checkout transaction. In particular, while the checkout clerk is entering the customers items for purchase during an assisted checkout transaction, transaction information such as item price and total dollar amount are displayed on the display monitor 78a. In addition to such transaction information, customer-specific advertisements may be displayed on a portion of the display monitor 78a in order to influence the customer to buy additional items. For example, the customer profile associated with a given customer may be initially retrieved from the customer profile database. Thereafter, the processing unit 78b causes customer-specific advertisements to be displayed on the display monitor 78b based on the contents of the customer's profile. For example, if the customer profile of a given customer indicates that the customer buys a certain type of beer during each of his or her visits to the retailer's store, the processing unit 78b may cause an advertisement for the certain type of beer to be displayed on the display monitor 78b in order to entice the customer to buy beer if the checkout clerk has not yet entered beer into the checkout system 10. It should be appreciated that any type of criteria may be established to fit the needs of given retailer in regard to analyzing the contents of the customer profile database for the purposes of selecting an appropriate customer-specific advertisement message. Moreover, as discussed above, the customer-specific message may also be displayed on the display monitor 76a of the personnel interface terminal 76 so that such a message may be viewed by the checkout clerk.

As discussed above, the processing unit 78b preferably includes a number of local memory devices such as the memory modules 78d (see FIG. 9) and a hard drive. The local memory devices are provided to maintain the operating system software needed to operate the checkout system 10. In addition, the local memory devices are provided to maintain an electronic transaction table which includes a record of the product information associated with each item that is scanned, weighed, or otherwise entered during the user's operation of the checkout system 10. For example, if the user scans a can of soup, the description of the soup and the pricing information associated therewith is recorded in the transaction table in the local memory devices. Similarly, if the user weighs a watermelon with the product scale 26 and then enters a product lookup code associated with watermelon via a data input device such as the terminals 76, 78, product information associated with the watermelon is recorded in the transaction table. Moreover, if a user entered a coupon or voucher, the information associated therewith would also be recorded in the transaction table.

It should therefore be appreciated that the sum of each of the items recorded in the transaction table (1) minus any reductions (e.g. coupons), and (2) plus any applicable taxes is the amount that the customer pays for his or her transaction. Moreover, data stored in the transaction table is printed out on the receipt printer 54 thereby generating a receipt for the customer at the end of his or her transaction.

The local memory devices are also provided to maintain a number of electronic logs associated with operation of the checkout system 10. More specifically, the local memory devices electronically maintain a number of event logs each of which respectively tracks or otherwise tallies the number of occasions in which the user operates the checkout system 10 in a particular manner. An event log may be provided to track those occasions in which the user unintentionally operated the checkout system 10 improperly, along with those occasions in which it can be inferred with a high degree of confidence that the user intentionally operated the checkout system 10 improperly for illicit purposes such as theft. For

example, if the processing unit **78b** determines that the user placed an item into the post-scan area **18** without having previously scanned or otherwise entered the item into the system **10**, an entry is made in an event log corresponding to such activity. This is true since the user may have unintentionally operated the scanner **24** incorrectly thereby preventing the scanner **24** from reading the bar code printed on the item. However, the possibility does exist that the user may have intentionally prevented the scanner **24** from reading the bar code printed on the item (e.g. the user may have placed his or her thumb over the bar code during the scanning attempt). Therefore, an entry is made in an event log corresponding to such activity (i.e. placing an item in the post-scan area **18** without having first entered the item into the system **10**).

Moreover, a separate event log may be maintained to track those occasions in which a user does not properly correct a prior misuse of the system **10**. For example, if the processing unit **78b** determines that the user placed an item into the post-scan area **18** without having previously scanned or otherwise entered the item into the system **10** in the manner discussed above, the processing unit **78b** causes a message to be displayed on the display monitor **76a** of the personnel interface terminal **76** (in the case of operation of the system **10** by a checkout clerk) or the display monitor **78a** of the interactive customer interface terminal **78** (in the case of operation of the system **10** by a customer) which instructs the user (i.e. the checkout clerk or the customer) to remove the item from the post-scan area **18** and thereafter properly enter the item. A separate even log is maintained in order to track the number of occasions in which the user does not follow such instruction or performs an additional improper operation. For example, if subsequent to such instruction the user removes a different item, or no item at all, from the post-scan area **18**, an entry is made into the event log associated with such activity.

Additional examples of event logs which may be maintained include an event log which tracks the number of occasions in which the user weighs an item, such as produce, with the product scale **26**, but then places an item of a different weight in the post-scan area **18**. Moreover, a separate event log may be provided to track the number of occasions in which a user voids a first item from a transaction, but then removes a second item of lesser value from the post-scan area **18**. A separate event log may be maintained to track the dollar amount of the coupons which are entered by a given user. Yet further, a separate event log may be provided to track the amount of time which elapses from the point in time at which the customer removes his or her items from the post-scan area **18** until the point in time at which the customer tenders payment for his or her items.

Moreover, the local memory devices maintain an electronic aggregate log. The aggregate log tracks the total of each of the various event logs. It should be appreciated that such an aggregate log is particularly useful for monitoring a users "overall" operation of the checkout system **10**. In particular, while the occurrence of certain individual activities by a given user may not separately rise to a level of concern, the aggregate of such activities may be of concern to the retailer.

It should be appreciated that a separate, predetermined threshold value may be established for each of the numerous event logs and also the aggregate log. More specifically, a retailer may establish a threshold value for each of the logs that once equaled or exceeded causes the processing unit **78b** to communicate with certain system components in order to request intervention by retail personnel. In particular, when a

threshold value associated with one of the event logs or the aggregate log is equaled or exceeded, the processing unit **78b** may communicate with the paging device **86** in order to page or otherwise alert retail personnel as to certain events surrounding the operation of the checkout system **10** by a given user. After being alerted in such a manner, retail personnel will typically intervene into the transaction in order to either assist the user (in the case of inadvertent misuse of the system **10**) or audit and/or discontinue the transaction (in the case of intentional misuse or theft). It should be appreciated that the processing unit **78b** may also communicate with retail personnel via the status light device **84**.

Referring now to FIG. **10**, there is shown the power distribution scheme of the checkout system **10**. Power is distributed from a wall outlet **186** to the system components associated with the checkout system **10** by use of a number of power strips **188**. In particular, each of the power strips **188** is coupled to the wall outlet **186** via an uninterruptible power supply (UPS) **196**, whereas each of the system components is electrically coupled to the power strips **188**. Although not all of the system components shown in FIG. **9** are shown in FIG. **10** for purposes of clarity of description, it should be appreciated that such omitted system components (e.g. the belt mechanisms **20**, **56**, the digital camera **94a**, etcetera) are coupled to the power strips **188** in a similar manner as described below.

Use of the power strips **188** simplifies or otherwise enhances the cable management of the checkout system **10**. In particular, the power strips **188** are preferably located in relatively close proximity to the retail peripheral devices to which the power strips **188** are respectively coupled thereby reducing the distance across which the individual power cables associated with each peripheral device must be routed. For instance, it is preferable to mount one of the power strips **188** within the same terminal cabinet **28**, **30**, **32** in which the retail peripheral devices coupled to the particular power strip **188** are disposed.

In a specific example, as shown in FIG. **10**, one of the power strips **188** is secured within the terminal cabinet **32** so as to be located in relatively close proximity to the coin dispenser **48**, the coin acceptor **46**, the bill dispenser **52**, and the bill acceptor **50**. In such a configuration, the power cables respectively associated with each of the currency devices **46**, **48**, **50**, **52** (i.e. the serial communication lines **130**, **132**, **134**, **136**, respectively) are completely contained within the terminal cabinet **32**. Hence, in regard to the power strip **188** located in the terminal cabinet **32**, only the power cable which couples the power strip **188** located in the terminal cabinet **32** to the UPS **196** must be routed outside of the terminal cabinet **32**.

It should be appreciated that the other power strips **188** may positioned in a similar manner. For example, one of the power strips **188** may be positioned within the terminal cabinet **30** in order to be located in relatively close proximity to the retail peripheral devices to which the particular power strip **188** is coupled (e.g. the security scale **68** or the signature capture device **102**).

Moreover, the power strips **188** include a number of female power connectors **188a** which are configured to receive a corresponding male connector **190a** associated with a first end of a peripheral power cable **190**. A second end of the peripheral power cable **190** includes a female connector **190b** which is configured to be received into a male power connector **192** associated with each of the system components such as the interactive customer interface terminal **78**, the personnel interface terminal **76**, the inter-

face unit **140**, the assembly of the scanner **24** and the product scale **26**, the receipt printer **54**, the electronic payment terminal **44**, the security scale **68**, the signature capture device **102**, the journal printer **88**, the coin dispenser **48**, the coin acceptor **46**, the cash dispenser **52**, and the bill acceptor **50**.

Each of the female connectors **188a**, the male connectors **190a**, the female connectors **190b**, and the male connectors **192** is configured in accordance with an accepted international standard for power connectors. What is meant herein by the term "accepted international standard for power connectors" is a power connector standard which is promulgated by an international standards organization for use in substantially all countries. One such accepted international standard for power connectors includes an IEC 60320 international standard for power connectors (including all variations and iterations thereof) which is promulgated by the International Electrotechnical Commission (IEC).

Similarly, each of the power strips **188** includes a number of male power connectors **188b** which are configured to receive a corresponding female connector **194a** associated with a first end of a UPS power cable **194**. A second end of the UPS power cable **194** includes a male connector **194b** which is configured to be received into a female power connector **196a** associated with the UPS **196**. The male power connectors **188b**, the female connectors **194a**, the male connectors **194b**, and the female power connectors **196a** are each configured in accordance with an accepted international standard for power connectors such as the IEC 60320 international standard for power connectors.

Moreover, the UPS **196** includes a male power connector **196b** which is configured to receive a corresponding female connector **198a** associated with a first end of an outlet power cable **198**. A second end of the outlet power cable **198** includes a male connector **198b** which is configured to be received into a power outlet such as the wall outlet **186**. The male power connector **196b** and the female connector **198a** are both configured in accordance with an accepted international standard for power connectors such as the IEC 60320 international standard for power connectors. However, the male power connector **196b** is configured in accordance with an accepted country-specific standard for power connectors. What is meant herein by the term "accepted country-specific standard for power connectors" is a power connector standard which is promulgated by a national standards organization or a de facto standard which is otherwise in use within a particular country which may or may not conform to an accepted international standard for power connectors. One such accepted country-specific standard for power connectors includes a standard promulgated by the American National Standards Institute (ANSI) or the National Electrical Manufacturers Association (NEMA) for use in conjunction with the three-prong connector configuration widely utilized throughout the United States (e.g. NEMA 5-15P for plug connectors and NEMA 5-15R for the associated receptacle connectors).

Such use of power connectors which conform to the IEC 60320 international standard for power connectors provides the checkout system **10** with numerous advantages over heretofore designed checkout systems. For example, use of power connectors which conform to the IEC 60320 international standard for power connectors facilitates the importation process of the checkout system **10** into foreign countries. In particular, heretofore designed checkout systems utilize power strips and power cables which have numerous connectors which conform to an accepted country-specific standard for power connectors. For example, checkout systems designed and/or manufactured for use the United States

typically have receptacles that have female connectors which conform to U.S. standards (e.g. an applicable ANSI and/or NEMA standard) for receiving a male connector associated with a power cord of a peripheral device which also conforms to U.S. standards (e.g. an applicable ANSI and/or NEMA standard). The female connector of the peripheral power cord (i.e. the connector secured to the end of the power cable which connects to the male connector of the peripheral device) may or may not be configured in accordance with an international standard for power connectors. For example, a number of peripheral devices include male power connectors which conform to the IEC 60320 international standard for power connectors. Hence, the power cable associated with such a peripheral device typically has a female power connector which conforms to the IEC 60320 international standard for power connectors for coupling with the male connector of the peripheral device at one end, and a standard U.S. male power connector (e.g. a male connector that conforms to an applicable ANSI and/or NEMA standard) on the other end for coupling with a standard U.S. outlet such as the standard U.S. female power connectors associated with a power receptacle.

However, when such use of standard U.S. power connectors is discovered by an inspection officer or the like during importation of the checkout system into a foreign country, the checkout system may be denied immediate entry into the foreign country. In particular, importation of the checkout system into the foreign country may be delayed until a certificate of conformance or the like is presented to the inspection officer. Such delays can often take weeks thereby significantly slowing the delivery process of the checkout system to a retailer located in a foreign country.

However, the checkout system **10** of the present invention avoids such delays. In particular, when the inspection officer inspects the checkout system **10** during importation thereof into a foreign country, all of the power connectors associated with the checkout system **10** conform to the IEC 60320 international standard for power connectors thereby eliminating the need for a certificate of conformance or other documentation in regard to the power distribution architecture of the system **10**.

Moreover, only the outlet power cable **198** needs to be swapped in order to operate the checkout system **10** in various foreign countries. In particular, a different outlet power cable **198** having a male connector **198b** which is configured to be received into the country-specific wall outlet of each foreign country may be utilized to couple the UPS **196** (and hence the power strips **188**) to the wall outlet **186**. In such a manner, power may be supplied to each of the system components associated with the checkout system. More specifically, each of the system components associated with the checkout system **10** includes an auto-ranging power supply (not shown) which is capable of converting a wide variety of AC input voltages into the regulated, predetermined DC voltage needed to operate the particular system component. For example, the individual power supplies respectively associated with each of the system components are configured to convert input power provided in either a European standard (e.g. 240V AC at 50 Hz), a U.S. standard (e.g. 110V AC at 60 Hz), or any other standard into the regulated, predetermined DC voltage needed to operate the particular system component. Hence, by swapping the outlet power cable **198** to fit into the country-specific wall outlet **186** of a given foreign country, power may be supplied to the system components without the need to also change any of the internal cable connections (i.e. the power cables **190** and **194**) or power supplies within the checkout system **10**.

It should be appreciated that the use of the power strips **188** and the port expander devices **108, 110** provides for “modular construction” of the checkout system **10** by simplifying or otherwise enhancing the cable management of the checkout system **10**. In particular, the port expander device **108, 110** and the power strips **188** are preferably located in relatively close proximity to the retail peripheral devices to which the port expander devices **108, 110** and the power strips **188** are respectively coupled thereby reducing the distance across which the individual data and power cables associated with each peripheral device must be routed. For instance, it is preferable to mount one or more of the port expander devices **108, 110** and one or more of the power strips **188** within the same terminal cabinet **28, 30, 32** in which the retail peripheral devices coupled to the particular port expander devices **108, 110** or the particular power strips **188** are disposed.

In such a manner, as described above, each of the data and power cables associated with the retail peripheral devices are completely contained within the respective terminal cabinets **28, 30, 32**. This allows the system configuration of the checkout system **10** to be quickly and easily changed to fit the needs of a given retailer. For example, as shown in FIG. **29**, in certain retail applications it may be desirable to configure the checkout system **10** without the input belt mechanism **20**. In such a configuration, a terminal cabinet **28'** having a flat surface or counter **276** secured thereto may be utilized in lieu of the terminal cabinet **28**. Such a change in the configuration of the checkout system **10** is relatively easy to perform since the terminal cabinet **28** does not have data or power cables routed therethrough, except for the cables necessary for operation of the components associated with the terminal cabinet **28** (e.g. the item sensors **98, 100** and the input belt mechanism **20**).

It should be appreciated that other terminal cabinet substitutions may also be quickly and easily performed due to such modular construction of the checkout system **10**. For example, if a certain retailer does not desire a takeaway belt mechanism **56** and bagging counter **66**, the terminal cabinet **32** may be removed and substituted for a cabinet having a configuration which meets the retailer's requirements.

Moreover, such modular construction of the checkout system **10** also allows the core design of the system to be utilized in the construction of other types of checkout systems. For example, as shown in FIG. **30**, the modular construction of the checkout system **10** allows the core components of the system to be utilized in the design of a dedicated self-service checkout system **10'**. The self-service checkout system **10'** utilizes a similar design concept as the checkout system **10**, but is not convertible into an assisted checkout system. Such a configuration is useful for retailers which desire a full-time self-service solution.

Moreover, as shown in FIG. **31**, the modular construction of the checkout system **10** allows the core components of the system to be utilized in the design of a second type of dedicated self-service checkout system **10''**. The self-service checkout system **10''** is substantially the same as the self-service checkout system **10'**, but the cash payment devices **46, 48, 50, and 52** and the coupon acceptor **178** have been removed. Such a configuration further reduces costs associated with manufacture of the system **10''** by providing a system which accepts payment via debit, credit, or smart card only.

#### OPERATION OF THE PRESENT INVENTION

In operation, the checkout system **10** may be operated to perform an assisted checkout transaction or a self-service

checkout transaction. In particular, the checkout system **10** may be operated to perform an assisted checkout transaction in which retail personnel such as a checkout clerk assists the customer during the transaction. Prior to performing an assisted checkout transaction, system components associated with the checkout system **10** are first positioned in their respective assisted positions. In particular, the scanner **24** is first rotated into its assisted scanner position by, as shown in FIG. **11**, sliding the sliding drawer assembly **38** into its extended position such that the scanner **24** (and hence the product scale **26**) may be rotated to its assisted scanner position in which the vertical scanning window **24b** faces the personnel side **42** of the checkout system **10**. Thereafter, the sliding drawer assembly is slid back into its retracted position within the interior of the terminal base **34** such that operation of the scanner **24** by the checkout clerk may be commenced (see FIGS. **1-4**).

Moreover, the personnel interface terminal **76** is rotated to its operative position in which the display monitor **76a** associated therewith faces the personnel side **42** of the checkout system **10**. In particular, as shown in FIGS. **1-4** and **23**, the terminal support member **80** (and hence the personnel interface terminal **76**) may be rotated relative to the housing **82** which houses the vertical scanning window **24b** of the scanner **24** such that the display monitor **76a** and the keypad **76b** face the personnel side **42** of the checkout system **10**.

Yet further, the set-aside item shelf **70** is moved relative to the terminal base **34** so as to be positioned in its assisted shelf position. In particular, as shown in FIGS. **1-4, 12, and 13**, the set-aside item shelf **70** may be slid or pivoted (depending on the type of mounting configuration utilized to secure the shelf **70** to the terminal base **34**) to its assisted shelf position such that items may be positioned thereon by the checkout clerk during an assisted checkout transaction.

Moreover, as shown in FIGS. **1** and **19**, prior to operation of the checkout system **10** in its assisted mode of operation, the support arm assembly **160** is manipulated so as to cause the interactive customer interface terminal **78** to assume its assisted terminal position in which the display monitor **78a** faces the general direction of the payment area **16**. It should be appreciated that during an assisted checkout transaction, the customer is generally positioned in the proximity of the payment area **16**. Hence, by positioning the display monitor **78a** in the position shown in FIG. **19** (i.e. an assisted monitor position), retail information, along with other messages such as customer-specific advertisements, may be displayed on the display monitor **78a** for viewing by the customer while the checkout clerk enters the customer's items for purchase with the scanner **24**.

In addition, the takeaway belt **58** associated with the takeaway belt mechanism **56** may be positioned to allow the checkout clerk to selectively advance items to either the assisted bagwell **62** or the bagging counter **66**. In particular, the takeaway belt **58** may be slid between an extended position (see FIG. **12**) and a retracted position (see FIG. **13**). As shown in FIG. **13**, when the takeaway belt **58** is positioned in its retracted position, an end portion **58a** of the takeaway belt **58** is spaced apart from the scanner **24** so as to expose the overhead access opening **62a** associated with the assisted bagwell **62** in order to allow the checkout clerk operating the scanner **24** to place an item into a grocery bag within the assisted bagwell **62** once the item has been scanned. Conversely, as shown in FIG. **12**, when the takeaway belt **58** is positioned in its extended position, the end portion **58a** of the takeaway belt **58** is positioned proximate to the scanner **24** so as to cover the overhead access opening **62a** associated with the assisted bagwell **62** in order to allow the checkout

clerk operating the scanner **24** to place an item onto the takeaway belt **58** once the item has been scanned in order to allow the item to be transported to the bagging counter **66** by the takeaway belt mechanism **56**.

It should be appreciated that once the system components associated with checkout system **10** have been positioned in the manner described above, retail personnel actuates the system **10**. For example, the checkout clerk toggles the supervisor switch **106** (see FIG. **9**) so as to cause the processing unit **78b** to execute an assisted version of the operating system software associated with the checkout system **10**. In particular, although the operating system software is essentially the same for checkout system **10** irrespective of whether or not the system **10** is being operated in its self-service mode of operation or its assisted mode of operation, certain system functions may be enabled or disabled as the system **10** is switched between its two modes of operation based on a particular system configuration. Moreover, prior to operation of the checkout system **10** in its assisted mode of operation, the checkout clerk preferably actuates the lane light **104** (see FIG. **9**) so as to cause the lane light **104** to illuminate a "FULL-SERVICE" message so as to indicate to customers that the particular checkout system is being operated as an assisted checkout system in which a checkout clerk is available to assist the customer.

Referring now to FIG. **25**, there is shown a flowchart which sets forth a general procedure **200** for checking out items through the checkout system **10** when the system **10** is being operated in its assisted mode of operation. It should be appreciated that when the customer arrives at the checkout system **10**, the system **10** is in an idle state (step **202**). An initialization step **204** is executed prior to checking out items for purchase. In particular, the checkout clerk operating the system **10** enters certain information about the transaction such as pressing a particular button on the keypad **76b** associated with the personnel interface terminal **76** in order to select a desired method of payment, and/or (2) identifying the customer by having the customer swipe his or her loyalty card, debit card, credit card, or smart card through the card reader associated with the electronic payment terminal **44**.

At the completion of the initialization step **204**, the routine **200** advances to an itemization step **206** where the checkout clerk enters the customer's individual items for purchase by scanning the items across the scanner **24**. Moreover, in step **206**, the checkout clerk may enter items, such as produce items or the like, by weighing the items with the product scale **26**, and thereafter entering a product lookup code associated with the item via the keypad **76b** associated with the personnel interface terminal **76**. Further, in step **206** the customer may enter an item by manually entering the product identification code associated with the item via use of the keypad **76b** associated with the personnel interface terminal **76**. Such manual entry of an item may be necessary for items (which would otherwise be entered via the scanner **24**) if the product identification code printed on the item is not readable by the scanner **24** or if the item is too large or bulky to be scanned with the scanner **24**. It should be appreciated that the checkout system **10** may be alternatively configured such that the routine **200** allows the checkout clerk to bypass the initialization step **204** thereby advancing directly to the itemization step **206**. In such a configuration, the checkout clerk would begin the transaction by scanning or otherwise entering the customer's first item for purchase.

At the completion of the itemization step **206**, an end-of-itemization control signal is generated and the routine **200** advances to a finalization step **208** in which (1) a transaction receipt is printed by the receipt printer **54**, (2) a record of the

transaction is printed on the journal printer **88**, and (3) payment is tendered by either inserting currency into a currency acceptor (i.e. the coin acceptor **46** and/or the bill acceptor **50**), charging a credit card or debit card account, or decreasing a value amount stored on a smart card via the electronic payment terminal **44**. In the case of when a customer inserts currency into the coin acceptor **46** and/or the bill acceptor **50**, the checkout system **10** may provide change via a currency dispenser (i.e. the coin dispenser **48** and/or the bill dispenser **52**). After completion of the finalization step **208**, the routine **200** returns to step **202** in which the checkout system **10** remains in the idle condition until subsequent initiation thereof.

As described, execution of such a procedure provides numerous advantages to the checkout system **10** of the present invention. For example, by operating the checkout system **10** such that payment is tendered by the customer by use of the currency acceptors (i.e. the coin acceptor **46** and/or the bill acceptor **50**) or the electronic payment device **44** without the assistance of the checkout clerk allows the checkout clerk to begin a subsequent transaction while the customer completes the current transaction thereby enhancing the efficiency and throughput associated with the checkout system **10**. Similarly, operation of the electronic payment terminal **44** and generation of the transaction receipt on the customer side **40** of the checkout system **10** allows the customer to complete his or her transaction without further assistance from the checkout clerk thereby further enhancing the efficiency and throughput associated with the checkout system **10**.

During operation of the checkout system **10** in its assisted mode of operation, a number of software routines are executed to provide security from improprieties such as theft. For example, as shown in FIG. **26**, a scale security routine **210** is executed during the itemization step **206** (see FIG. **25**) when the checkout system **10** is being operated with the takeaway belt **58** positioned in its retracted belt position (see FIG. **13**) in which the checkout clerk is himself or herself bagging the customer's items for purchase. The scale security routine **210** monitors output from the security scale **68** thereby monitoring the movement of items into and out of the post-scan area **18** in an effort to prevent "sweet-hearting" (e.g. a situation in which the checkout clerk scans a first item, but then places a second, more expensive item, or even an item that the clerk never even attempted to scan, into the customer's bag in order to provide an improper benefit to the customer who is typically an acquaintance of the checkout clerk).

The scale security routine **210** begins with step **212** in which the processing unit **78b** determines if an item has been entered into the checkout system **10** by the checkout clerk. In particular, the processing unit **78b** scans or reads the output from the scanner **24** in order to determine if the scanner **24** has successfully read or otherwise captured the product identification code associated with an item. More specifically, the scanner **24** generates an output signal which is sent to the processing unit **78b** once the scanner **24** successfully reads the product identification code associated with the item. Similarly, the processing unit **78b** scans or reads the output from the product scale **26** and the keypad **76b** associated with the personnel interface terminal **76** to determine if the checkout clerk weighed an item such as produce with the product scale **26** and thereafter entered a product lookup code associated with the item via the keypad **76b**. Moreover, the processing unit **78b** also monitors output from the keypad **76b** associated with the personnel interface terminal **76** in order to determine if the checkout clerk manu-

ally entered a product identification code associated with an item that was unable to be scanned with the scanner 24. Hence in step 212, if an item is entered into the checkout system 10, an item-entered control signal is generated and the scale security routine 210 advances to step 214. If an item has not been entered into the checkout system 10 by the checkout clerk, the scale security routine 210 advances to step 216.

In step 214, the processing unit 78b retrieves a stored weight value of the entered item from a weight database. In particular, the processing unit 78b communicates with either a local memory device (e.g. the memory modules 78d or the hard drive) or a network memory device associated with the retailers network 184 in order to retrieve the stored weight value associated with the entered item from the weight database. As discussed above, the weight database may be in the form of a master database which includes every item sold by the retailer, or may be a "transaction level" database which is constructed locally at the checkout system 10 during operation thereof. In either event, once the stored weight value of the entered item has been retrieved from the weight database, the scale security routine 210 advances to step 218.

In step 218, the processing unit 78b determines if the entered item is placed in the post-scan area 18. More specifically, the security scale 68 generates an output or detection signal which is sent to the processing unit 78b once the security scale 68 has detected placement of an item (1) into one of the grocery bags within the assisted bagwell 62, or (2) onto the set-aside item shelf 70. If the security scale 68 detects placement of an item into the post-scan area 18, the scale security routine 210 is advanced to step 220. If the security scale does not detect placement of the item into the post-scan area 18, the scale security routine 210 loops back to step 218 to monitor for subsequent placement of the item into the post-scan area 18. It should be appreciated that the checkout system 10 may be configured to allow for the entry of items without the item being subsequently placed in the post-scan area 18. For example, if the checkout clerk scans a pack of gum, the gum may be handed directly to the customer so that the customer may place the gum into his or her pocket instead of a grocery bag. In such a situation, the scale security routine 210 would be configured to loop back to step 212 to monitor entry of subsequent items if a previously entered item is not placed into the post-scan area 18 within a predetermined time.

As described above, if the security scale 68 detects placement of an item into the post-scan area 18, the scale security routine 210 is advanced to step 220. In step 220, the processing unit 78b determines if the measured weight value of the item placed in the post-scan area 18 (as detected by the security scale 68 in step 218) matches the stored weight value of the entered item that was retrieved from the weight database in step 214. What is meant herein by the terms "match", "matches", or "matching" in regard to weight values is that the magnitude of a first weight value is either equal to, or within a predetermined tolerance range of, the magnitude of a second weight value. For example, two weight values "match" if they are identical weight values. Moreover, a first weight value "matches" a second weight value if the first weight value is within 2% of the second weight value (assuming a 3% tolerance range). Yet further, a first weight value "matches" a second weight value if the first weight value is within 0.05 pounds of the second weight value (assuming a tolerance range of 0.10 pounds).

Hence, in step 220, the processing unit 78b compares the weight value of the item placed (1) into one of the grocery bags in the assisted bagwell 62, or (2) onto the set-aside item

shelf 70 (as measured by the security scale 68) with the stored weight value of the entered item that was retrieved from the weight database in step 214. If the measured weight value of the item placed into the post-scan area 18 matches the stored weight value of the item retrieved from the weight database, the scale security routine 210 advances to step 222. If the measured weight value of the item placed into the post-scan area 18 does not match the stored weight value of the item retrieved from the weight database, the scale security routine 210 advances to step 224.

In step 222, the processing unit 78b determines that a successful checkout operation has been completed for the particular item selected for purchase. More specifically, the processing unit 78b concludes that (1) the checkout clerk apparently scanned or otherwise entered the item since a code associated with the item was detected in step 212, and (2) the same item was placed in the post-scan area 18 since the weight values matched in step 220. Hence, the processing unit 78b adds a record of the properly entered item into the transaction table. In particular, the processing unit 78b communicates with the network 25 to obtain product information (e.g. description and price) associated with the entered item. Thereafter, the processing unit 78b updates the transaction table. More specifically, the processing unit 78b generates an output signal which is sent to the local memory devices (e.g. the memory modules 78d or the hard drive) which causes the transaction table to be updated in the local memory devices to include the product information associated with the scanned item. As described above, the sum of each of the items recorded in the transaction table (1) minus any reductions (e.g. coupons), and (2) plus any applicable taxes is the amount that the customer pays for his or her transaction. Moreover, data stored in the transaction table is printed out on the receipt printer 54 thereby generating a receipt for the customer at the end of his or her transaction. Once the transaction table has been updated, a valid-use control signal is generated, and the scale security routine 210 advances to step 226.

In step 226, the processing unit 78b monitors the output from the keypad 76b associated with the personnel interface terminal 76. In particular, the checkout clerk touches a particular key of the keypad 76 when the checkout clerk has completed scanning or otherwise entering all of the customers items for purchase. If a particular signal is generated by the keypad 76b, the processing unit 78b determines that the itemization procedure 206 is complete and the scale security routine 210 ends thereby advancing the general routine 200 (see FIG. 25) to the finalization step 208. If a particular signal is not generated by the keypad 76b, the processing unit 78b determines that the checkout clerk has additional items to enter, and the scale security routine 210 loops back to step 212 to monitor subsequent item entry.

Returning now to step 220, if the measured weight value of the item placed into the post-scan area 18 does not match the stored weight value of the entered item retrieved from the weight database, the scale security routine advances to step 224. In step 224, the processing unit 78b increments the aggregate log and a particular event log associated with item substitutions by a predetermined value. More specifically, the processing unit 78b generates an output signal which is sent to the local memory devices (e.g. the memory modules 78d or the hard drive) which causes the event log and the aggregate log to be incremented in the local memory devices by a value of one.

Thereafter, the processing unit 78b determines if the total value of either the event log associated with item substitutions or the aggregate log exceeds the respective predeter-



mined threshold value for each log. More specifically, if the event log associated with item substitutions exceeds its predetermined threshold value, the processing unit 78b causes an output signal to be generated which causes the paging device 86 and the status light device 84 to be operated to page or otherwise summon retail personnel such as a manager in order to assist and/or investigate the checkout clerk to determine if the checkout clerk is attempting to provide improper benefits to the customer such as by "sweethearting". In addition, if the aggregating log exceeds its predetermined threshold value, the processing unit 78b generates an output signal which causes the paging device 86 and the status light device 84 to be operated to page or otherwise summon retail personnel such as a manager in order to assist and/or investigate the checkout clerk in a similar manner. The scale security routine 210 then advances to step 228.

In step 228, the processing unit 78b causes a message to be displayed on the display monitor 76a associated with the personnel interface terminal 76 which instructs the checkout clerk to remove the item from the post-scan area 18 and thereafter place the proper item into the post-scan area. The scale security routine 210 then advances to step 230.

In step 230, the processing unit 78b communicates with the security scale 68 in order to determine if the substituted item is removed from the post-scan area 18 by the checkout clerk, as instructed. In particular, the security scale 68 generates an output signal which is sent to the processing unit 78b when the checkout clerk (1) removes the substituted item from one of the grocery bags in the assisted bagwell 62, or (2) takes the substituted item off of the set-aside item shelf 70. It should be appreciated that the processing unit 78b compares the weight value of the removed item to the weight value of the substituted item that was determined when it was placed in the post-scan area 18 (as detected in step 218) in order to ensure that the proper item is removed. If the proper item is removed from the post-scan area 18, an item-removed control signal is generated and the scale security routine 210 loops back to step 218 to monitor subsequent placement of the correct item into the post-scan area 18. If the proper item has not yet been removed from the post-scan area 18, the scale security routine 210 loops back to step 230 to monitor subsequent removal of the proper item from the post-scan area 18.

Returning now to step 212, if an item was not scanned or otherwise entered into the checkout system 10, the scale security routine 210 advances to step 216. In step 216, the processing unit 78b determines if an unentered item is placed in the post-scan area 18. More specifically, the security scale 68 generates an output or detection signal which is sent to the processing unit 78b once the security scale 68 has detected placement of an item (1) into the assisted bagwell 62, or (2) onto the set-aside item shelf 70. If the security scale 68 detects placement of an unentered item into the post-scan area 18, an invalid-use control signal is generated, and the scale security routine 210 is advanced to step 232. If the security scale 68 does not detect placement of an unentered item into the post-scan area 18, the processing unit 78b concludes that there is no present item entry attempt being made by the checkout clerk, and the scale security routine 210 loops back to step 212 to monitor for subsequent item entry.

In step 232, the processing unit 78b increments the aggregate log and a particular event log associated with unentered item placement (i.e. placement of an unentered item into the post-scan area 18) by a predetermined value. More specifically, the processing unit 78b generates an output signal which is sent to the local memory devices (e.g. the

memory modules 78d or the hard drive) which causes the event log associated with unentered item placement and the aggregate log to be incremented in the local memory devices by a value of one.

Thereafter, the processing unit 78b determines if the total value of either the event log associated with unentered item placement or the aggregate log exceeds the respective predetermined threshold value for each log. More specifically, if the event log associated with unentered item placement exceeds its predetermined threshold value, the processing unit 78b causes an output signal to be generated which causes the paging device 86 and the status light device 84 to be operated to page or otherwise summon retail personnel such as a manager in order to assist and/or investigate the checkout clerk to determine if the checkout clerk is attempting to provide improper benefits to the customer such as by "sweethearting". In addition, if the aggregate log exceeds its predetermined threshold value, the processing unit 78b generates an output signal which causes the paging device 86 and the status light device 84 to be operated to page or otherwise summon retail personnel such as a manager in order to assist and/or investigate the checkout clerk in a similar manner. The scale security routine 210 then advances to step 234.

In step 234, the processing unit 78b causes a message to be displayed on the display monitor 76a associated with the personnel interface terminal 76 which instructs the checkout clerk to remove the unentered item from the post-scan area 18 and thereafter properly scan or otherwise enter the item into the checkout system 10. The scale security routine 210 then advances to step 236.

In step 236, the processing unit 78b communicates with the security scale 68 in order to determine if the unentered item is removed from the post-scan area 18 by the checkout clerk, as instructed. In particular, the security scale 68 generates a removal output signal which is sent to the processing unit 78b when the checkout clerk (1) removes the unentered item from one of the grocery bags in the assisted bagwell 62, or (2) takes the unentered item off of the set-aside item shelf 70. It should be appreciated that the processing unit 78b compares the weight value of the removed item to the weight value of the unentered item that was determined when it was placed in the post-scan area 18 (as detected in step 216) in order to ensure that the proper item is removed. In particular, the processing unit 78b generates a match control signal if the weight value of the removed item matches the weight value of the unentered item that was placed in the post-scan area 18. In response to generation of the match control signal, the processing unit 78b causes a message to be displayed on the display monitor 76a which instructs the checkout clerk to reenter the item. Hence, in step 236, if the proper item is removed from the post-scan area 18, an item-removed control signal is generated and the scale security routine 210 loops back to step 212 to monitor subsequent entry of the item. If the proper item has not yet been removed from the post-scan area 18, or a different item is removed, an instruction is displayed on the display monitor 76a which instructs the checkout clerk to remove the proper item, and the scale security routine 210 loops back to step 236 to monitor subsequent removal of the proper item from the post-scan area 18.

As described above, use of the scale security routine 210 provides the checkout system 10 with numerous advantages over heretofore designed checkout systems. For example, as described in detail above, use of the scale security routine 210 provides security from improprieties such as "sweethearting" during operation of the checkout system 10 by a

checkout clerk. Such capabilities are not possible with heretofore designed assisted checkout systems. This is true since heretofore designed assisted checkout systems have not been configured with a security scale due to, amongst other reasons, cost of the scale. However, since the design of the checkout system 10 of the present invention includes a security scale (i.e. the security scale 68) for operation of the checkout system 10 in its self-service mode of operation, novel additions, manipulations, and modifications to the operation system software allows the security scale 68 to be utilized to provide security against improprieties on the part of the checkout clerk during operation of the checkout system 10 in its assisted mode of operation without adding additional costs to manufacture of the system 10.

It should be appreciated that other security mechanisms may also be operated during operation of the checkout system 10 in its assisted mode of operation. For example, the security deactivation device 172 of the present invention is operated to generate a deactivation field in the form of a magnetic field or electromagnetic field during operation of the checkout system 10 so as to deactivate electronic tags associated with items for purchase as the items are scanned by the checkout clerk with the scanner 24. In particular, as described above, the security deactivation device 172 generates a deactivation field (e.g. a magnetic and/or electromagnetic field) proximate to a scanner detection zone associated with the scanner 24. By generating the deactivation field proximate to the scanner detection zone, a scanning motion utilized by the checkout clerk to scan an item with the scanner 24 causes the item to be advanced through the deactivation field thereby deactivating the electronic security tag secured to the item in the same scanning motion.

Moreover, the video system 94 (see FIG. 9) may also be utilized to provide security from improprieties such as theft when the checkout system 10 is being operated in its assisted mode of operation. In particular, referring now to FIG. 27, a video security routine 250 is executed, for example, at the end of the itemization step 206 (see FIG. 25), prior to the beginning of the finalization step 208. The video security routine 250 monitors video images captured by the video camera 94a in order to determine if the customer's shopping receptacle (e.g. the shopping cart 238 or the shopping basket 240) is devoid of items.

The video security routine 250 beings with step 252 in which the processing unit 78b communicates with the video system 94 in order to capture and thereafter store video images associated with a shopping receptacle. In particular, the processing unit 78b operates the video system 94 so as to cause the video camera 94a to capture a video image of the shopping cart 238 or the shopping basket 240 (see FIG. 16) thereby creating an electronic video file of the captured video image of the shopping cart 238 or shopping basket 240. The video security routine 250 then advances to step 254.

In step 254, the processing unit 78b retrieves a reference electronic video file. In particular, the processing unit 78b communicates with either a local memory device (e.g. the memory modules 78d or the hard drive) or a network memory device associated with the retailers network 184 in order to retrieve the reference electronic video file therefrom. As discussed above, a reference video image of an empty shopping cart or shopping basket is stored as a reference electronic video file in either a local memory device associated with the checkout system (e.g. the memory modules 78d or a hard drive) or on a network memory device associated with the retailer's network 184. Once the reference electronic video file of the empty shopping cart or

shopping basket has been retrieved from the memory device, the video security routine 250 advances to step 256.

In step 256, the processing unit 78b compares the electronic video files in order to determine if the customer's shopping cart 238 or shopping basket 240 is devoid of items (i.e. empty). In particular, the electronic video file associated with the captured image of the shopping cart 238 or shopping basket 240 is compared to the reference electronic video file associated with an empty shopping cart or shopping basket. If the electronic video file associated with the captured image of the shopping cart 238 or shopping basket 240 matches the reference electronic video file associated with an empty shopping cart or shopping basket, a receptacle-empty control signal is generated and the scale security routine 250 ends thereby advancing the general routine 200 to the finalization step (see FIG. 25). However, if the electronic video file associated with the captured image of the shopping cart 238 or shopping basket 240 does not match the reference electronic video file associated with an empty shopping cart or shopping basket, an item-remaining control signal is generated and the video security routine 250 advances to step 258.

In step 258, the processing unit 78b increments by a predetermined value both the aggregate log and a particular event log associated with items remaining in a shopping receptacle. More specifically, the processing unit 78b generates an output signal which is sent to the local memory devices (e.g. the memory modules 78d or the hard drive) which causes the event log and the aggregate log to be incremented in the local memory devices by a value of one.

Thereafter, the processing unit 78b determines if the total value of either the event log associated with items remaining in a shopping receptacle or the aggregate log exceeds the respective predetermined threshold value for each log. More specifically, if the event log associated with items remaining in a shopping receptacle exceeds its predetermined threshold value, the processing unit 78b causes an output signal to be generated which causes the paging device 86 and the status light device 84 to be operated to page or otherwise summon retail personnel such as a manager in order to assist the checkout clerk in order to determine if the customer is attempting to commit an impropriety such as theft. In addition, if the aggregate log exceeds its predetermined threshold value, the processing unit 78b generates an output signal which causes the paging device 86 and the status light device 84 to be operated to page or otherwise summon retail personnel such as a manager in order to assist the checkout clerk in a similar manner. The video security routine 250 then advances to step 260.

In step 260, the processing unit 78b causes a message to be displayed on the display monitor 76a associated with the personnel interface terminal 76 which instructs the checkout clerk to inform the customer that he or she has items remaining in his or her shopping cart 238 or shopping basket 240. The video security routine 250 then advances to step 262.

In step 262, the processing unit 78b communicates with the video system 94 in order to capture and thereafter store a second video image associated with the shopping receptacle in order to determine if the customer removed the remaining item or items as instructed. In particular, the processing unit 78b operates the video system 94 so as to cause the video camera 94a to capture a second video image of the shopping cart 238 or the shopping basket 240 thereby creating a second electronic video file having the second captured video image of the shopping cart 238 or shopping basket 240. The video security routine 250 then advances to step 264.

In step 264, the processing unit 78b compares the electronic video files in order to determine if the customer removed the item or items from his or her shopping cart 238 or shopping basket 240 as instructed. In particular, the electronic video file associated with the second captured image of the shopping cart 238 or shopping basket 240 is compared to the reference electronic video file associated with an empty shopping cart or shopping basket. If the electronic video file associated with the second captured image of the shopping cart 238 or shopping basket 240 matches the reference electronic video file associated with an empty shopping cart or shopping basket, a receptacle-empty control signal is generated and the scale security routine 250 ends thereby advancing the general routine 200 to the finalization step (see FIG. 25). However, if the electronic video file associated with the second captured image of the shopping cart 238 or shopping basket 240 does not match the reference electronic video file associated with an empty shopping cart or shopping basket, an item-remaining control signal is generated and the video security routine 250 advances to step 266.

In step 266, the processing unit 78b generates a personnel-needed control signal in response to generation of the second item-remaining control signal. In particular, the processing unit 78b causes a message to be displayed on the display monitor 76a of the personnel interface terminal 76 which informs the checkout clerk of the item or items remaining in the customer's shopping cart 238 or shopping basket 240. Moreover, the processing unit 78b may also communicate with the paging device 86 and the status light device 84 in order to summon additional retail personnel such as a customer service manager.

As described above, use of the video security routine 250 provides the checkout system 10 with numerous advantages over heretofore designed checkout systems. For example, as described in detail above, use of the video security routine 250 provides security from unintentional or intentional improprieties such as theft in regard to items remaining in the customer's shopping receptacle. Such remaining items might otherwise be allowed to leave the retailer's store without having first been paid for.

Moreover, the video camera 94a may also be operated to capture a video image of the checkout clerk operating the checkout system 10. In a known manner, the captured video image of the checkout clerk is then stored in the form of an electronic video file by the processing unit 78b. A subsequent video image (which is representative of the captured video image) may then be extracted from the electronic video file for use by the checkout system 10. For example, an extracted video image of the checkout clerk (i.e. a video image extracted from the stored electronic file) could be displayed on the display monitor 76a of the personnel interface terminal 76 in order to serve as a psychological deterrent against "sweethearting" or other improprieties. Moreover, the extracted video image of the checkout clerk could be printed with the receipt printer 54 in order to serve as an additional psychological deterrent against "sweethearting" or other improprieties.

As alluded to above, the status light device 84 and the paging device 86 may be utilized during operation of the checkout system 10 in its assisted mode of operation in order to page or otherwise summon retail personnel to the checkout system 10. In particular, if during operation of the checkout system 10 in its assisted mode of operation, an intervention-needed activity is detected, the status light device 84 and the paging device 86 are operated so as to summon retail personnel such as a customer service man-

ager in order to provide assistance to the checkout clerk. As described in detail above, such an intervention-needed activity may take the form of a security-breach activity in which the checkout system 10 is being operated in a manner which is placing the retailer in a position of potential financial loss due to goods being taken from the store without having first been paid for (either intentionally or unintentionally). An intervention-needed activity may also take the form of a non-security-breach activity in which the checkout clerk is in need of assistance or the checkout system 10 is in need of maintenance, but the retailer is not at risk of financial loss due to goods being taken from the store without having first been paid for. For example, if the checkout clerk scanned a first item, but then placed a second item of greater value into a grocery bag as detected by, for example, the security scale 68 (e.g. "sweethearting"), the processing unit 78b concludes that an intervention-needed activity has occurred. Moreover, if the checkout clerk operating the system 10 touches a particular key on the keypad 76b associated with the personnel interface terminal 76 (see FIG. 23), thereby indicating that he or she is in need of assistance, the processing unit 78b concludes that an intervention-needed activity has occurred.

In addition, the processing unit 78b may monitor the status of the retail peripheral devices associated with the checkout system 10 in order to determine if an intervention-needed activity has occurred. For example, the processing unit 78b preferably monitors the currency level within the coin dispenser 48 and the bill dispenser 52 in order to determine if either currency dispenser 48, 52 is in need of restocking. Moreover, the processing unit 78b preferably monitors the paper supply level within the receipt printer 54 and a journal printer 88 (see FIG. 9) in order to determine if either printer 54, 88 is in need of restocking. It should be appreciated that if any one of the currency dispensers 48, 52 or the printers 54, 88 is in need of restocking, the processing unit 78b concludes that an intervention-needed activity has occurred.

As described above, once an intervention-needed activity has been detected, the status light device 84 is operated to summon retail personnel. For example, the status light device 84 may display a first colored light (e.g. yellow) in order to notify retail personnel that intervention is needed prior to the end of the current checkout transaction. Alternatively, the status light device 84 may display a second colored light (e.g. red) in order to notify retail personnel that intervention is needed immediately.

As with the status light device 84, the paging device 86 is utilized to page or otherwise summon retail personnel to the checkout system 10 once an intervention-needed activity has been detected. The paging device 86 is particularly useful since it is operable to communicate with retail personnel who are positioned at locations within or outside of the store which are out of the view of the status light device 84. In particular, the signal transmitter 86a of the paging device 86 communicates with a number of portable communication devices such as wireless alphanumeric pagers 90. Hence, upon detection of an intervention-needed activity by the processing unit 78b, an intervention-needed control signal is generated. Upon generation of an intervention-needed control signal, the signal transmitter 86a generates an RF personnel-request signal which is received by the pagers 90. The personnel-request signal includes a specific alphanumeric message which includes such information as the nature of the intervention which is needed and the identity of the particular checkout system 10 which requires assistance. For example, if one of the currency dispensers 48, 52 needs to be restocked, the signal transmitter 86a generates an RF

51

personnel-request signal which causes a message to be displayed on one of the pagers 90 which informs the customer service manager wearing the pager 90 that a particular checkout system 10 is, for example, running low on dimes.

Moreover, as shown in FIG. 22 and discussed above, the signal transmitter 86a may communicate with the signal receiver 92a associated with the intercom device 92 in order to generate audible messages which are broadcast to retail personnel within the store with the speakers 92b. In particular, upon detection of an intervention-needed activity by the processing unit 78b, an intervention-needed control signal is generated. Generation of an intervention-needed control signal causes the signal transmitter 86a to generate an RF personnel-request signal which is received by the signal receiver 92a associated with the intercom device 92. The personnel-request signal includes a specific code which corresponds to a number of specific, prerecorded audible messages stored in, or otherwise maintained by, the controller 92c of the intercom device 92. For example, each of the prerecorded messages may include such information as the nature of the intervention which is needed and the identity of the particular checkout system 10 which requires assistance. The controller 92c causes such prerecorded audible messages to be broadcast with the speakers 92b so as to be audibly detected by retail personnel such as a customer service manager within the retailer's store. For example, if one of the currency dispensers 48, 52 needs to be restocked, the signal transmitter 86a generates an RF personnel-request signal which, once received by the signal receiver 92a, causes an audible message to be broadcast on the speakers 92b which informs the customer service manager that a particular checkout system 10 is, for example, running low on dimes.

Additionally, during operation of the checkout system 10 in its assisted mode of operation, the display monitor 78a of the interactive customer interface terminal 78 may be utilized to display certain information to the customer while the checkout clerk is entering the customer's items for purchase. For example, a customer-specific message such as a customer-specific advertisement which advertises a product that was purchased by the customer during a previous visit to the retailer's store may be displayed on a first portion 272 of the display monitor 78a, as shown in FIG. 21, while transaction information such as item description and price is displayed on a second portion 274 of the display monitor 78a. In particular, during an assisted checkout transaction, the processing unit 78b retrieves information from a customer profile database which contains customer-specific information (e.g. previous purchases) about each of the retailer's customers. Hence, as shown in FIG. 21, if the customer routinely purchases "ACME BEER", an advertisement for "ACME BEER" may be displayed on the first portion 272 of the display monitor 78a while the checkout clerk is entering the customer's items for purchase.

Moreover, such a customer-specific message may include a customer-specific advertisement which advertises a product that may be used in conjunction with a product which was previously scanned or otherwise entered into the checkout system 10 during the current checkout transaction. For example, if the checkout clerk scans a case of beer included in the customer's items for purchase, an advertisement relating to pretzels may be displayed to the customer on the first portion 272 if the processing unit 78b since pretzels are commonly consumed with beer.

It should be appreciated that such customer-specific messages may also be communicated by other components associated with the checkout system 10. For example, customer-

52

specific messages may be displayed to the checkout clerk with the display monitor 76a of the personnel interactive terminal 76. For instance, if the checkout clerk scans a case of beer or other type of alcohol, a customer-specific message may be displayed on the display monitor 76a which informs the checkout clerk that the customer is not old enough to purchase the beer or other type of alcohol. Similarly, customer-specific advertisement messages could be displayed on the display monitor 76a in order to be verbally relayed or otherwise communicated to the customer in a personal manner by the checkout clerk.

As described above, the checkout system 10 may also be operated to perform a self-service checkout transaction in which the customer completes his or her checkout transaction without the assistance of retail personnel such as a checkout clerk. Prior to performing a self-service checkout transaction, system components associated with the checkout system 10 are first positioned in their respective self-service positions. In particular, the scanner 24 must be rotated from its assisted scanner position (as shown in FIGS. 1-4) to its self-service scanner position (as shown in FIGS. 5-8). As shown in FIG. 11, the sliding drawer assembly 38 is first slid into its extended position such that the scanner 24 (and hence the product scale 26) may be rotated from its assisted scanner position to its self-service scanner position in which the vertical scanning window 24b faces the customer side 40 of the checkout system 10. Thereafter, the sliding drawer assembly is slid back into its retracted position within the interior of the terminal base 34 such that operation of the scanner 24 by the customer may be commenced (see FIGS. 5-8).

It should be appreciated that the scanner 24 may be moved from the assisted scanner position to its self-service scanner position in other manners. In particular, as shown in FIG. 17, the scanner 24 may be embodied as a known "flatbed" scanner (hereinafter designated as scanner 24') which contains a single, horizontal scanning aperture similar to the horizontal scanning window 24a. In such a configuration, it is not necessary to rotate the scanner 24' between its assisted and self-service positions due to the absence of the vertical scanning window 24b. Hence, the scanner 24' may be slidably secured to the terminal base 34 in order to be slid between its assisted scanner position (as shown in phantom lines in FIG. 17) and its self-service scanner position (as shown in solid lines in FIG. 17). It should be appreciated that, as shown in phantom lines in FIG. 17, the personnel interface terminal 76 is mounted on a support such as a pole or the like in conjunction with use of the scanner 24' due to the absence of the housing 82.

Moreover, prior to operation of the checkout system 10 in its self-service mode of operation, the personnel interface terminal 76 is rotated to its operative position in which the display monitor 76a associated therewith faces the personnel side 42 of the checkout system 10. In particular, when the scanner 24 is rotated to its self-service scanner position as described above, the personnel interface terminal 76 (being mounted on the housing 82 which houses the vertical scanning window 24b) is likewise rotated thereby causing the display monitor 76a and the keypad 76b to face the customer side 40 of the checkout system 10. However, as described above, the personnel interface terminal 76 is not utilized by the customer when the checkout system 10 is being operated in its self-service mode of operation. Accordingly, it is desirable to position the personnel interface terminal 76 such that the display monitor 76a and the keypad 76b face away from the customer. As shown in FIGS. 5-8 and 24, the terminal support member 80 (and hence the personnel interface ter-

minal 76) may be rotated relative to the housing 82 which houses the vertical scanning window 24b of the scanner 24 such that the display monitor 76a and the keypad 76b face the personnel side 42 of the checkout system 10 when the checkout system 10 is operated in its self-service mode of operation.

It should be appreciated that such positioning of the personnel interface terminal 76 (i.e. facing it away from the customer) provides numerous advantages to the design of the checkout system 10 when it is being operated in its self-service mode of operation. For example, such positioning of the personnel interface terminal 76 reduces or potentially eliminates the possibility that the keypad 76b is accidentally operated by the customer. Moreover, by facing the keypad 76b and the display monitor 76a away from the customer, the customer is confronted with fewer system components when approaching the checkout system 10 which reduces the "intimidation effect" on new or inexperienced customers thereby rendering the new or inexperienced customer more likely to utilize the checkout system 10 as a self-service solution. Moreover, as shown in FIG. 24, such positioning of the personnel interface terminal 76 allows the laminated sign 80b secured to the surface 80a of the terminal support member 80 to be viewed by the customer. As described above, the message printed on the sign 80b is displayed to the customer in order present an advertisement for a product or service offered by the retailer. Moreover, the retailer may sell the space on the laminated sign 80b to an outside company or business (e.g. a real estate agent or mortgage broker) in order to generate additional revenue. The message printed on the sign 80b may alternatively include instructions which instruct the customer on operation of the checkout system 10.

Yet further, the set-aside item shelf 70 is moved relative to the terminal base 34 so as to be positioned in its self-service shelf position. In particular, as shown in FIGS. 5-8 and 15, the set-aside item shelf 70 may be slid or pivoted (depending on the type of mounting configuration utilized to secure the shelf 70 to the terminal base 34) to its self-service shelf position such that items may be positioned thereon by the customer during a self-service checkout transaction. As shown in FIG. 5, by positioning the set-aside item shelf 70 in its self-service position, the self-service bagwell 60 is exposed thereby allowing the customer to advance items into the grocery bags (not shown) located therein.

Moreover, as shown in FIGS. 5 and 20, prior to operation of the checkout system 10 in its self-service mode of operation, the support arm assembly 160 is manipulated so as to cause the interactive customer interface terminal 78 to assume its self-service terminal position in which the display monitor 78a faces the general direction of the area located in front of the self-service bagwell 60. It should be appreciated that during a self-service checkout transaction, the customer is generally positioned in the proximity of the area located in front of the self-service bagwell 60 in order to scan items with the scanner 24 and thereafter place the items in grocery bags positioned in the self-service bagwell 60. Moreover, by positioning the display monitor 78a in the position shown in FIG. 20 (i.e. a self-service monitor position), retail information such as transaction information (e.g. product prices and descriptions), along with other messages such as instructional and advertisement messages, may be displayed on the display monitor 78a for viewing by the customer while the customer enters his or her items for purchase with the scanner 24.

It should be appreciated that once the system components associated with checkout system 10 have been positioned in

the manner described above, retail personnel actuates the system 10 prior to allowing the first customer to operate the system 10. For example, the customer service manager toggles the supervisor switch 106 (see FIG. 9) so as to cause the processing unit 78b to execute a self-service version of the operating system software associated with the checkout system 10. In particular, although the operating system software is essentially the same for checkout system 10 irrespective of whether or not the system 10 is being operated in its assisted mode of operation or its self-service mode of operation, certain system functions may be enabled or disabled as the system 10 is switched between its two modes of operations based on a particular system configuration. Moreover, prior to operation of the checkout system 10 in its self-service mode of operation, the customer service manager preferably actuates the lane light 104 (see FIG. 9) so as to cause the lane light 104 to illuminate a "SELF-SERVICE" message in order to indicate to customers that the particular checkout system 10 is being operated as a self-service checkout system.

Referring now to FIG. 28, there is shown a flowchart which sets forth a general procedure 300 for checking out items through the checkout system 10 when the system 10 is being operated in its self-service mode of operation. It should be appreciated that when the customer arrives at the checkout system 10, the system 10 is in an idle state (step 302). An initialization step 304 is executed prior to checking out items for purchase. In particular, a message is displayed on the display monitor 78a associated with the interactive customer interface terminal 78 which instructs the customer to (1) to select a desired method of payment by touching a particular portion of the touch screen associated with the display monitor 78a, and/or (2) identify himself or herself by swiping his or her loyalty card, debit card, credit card, or smart card through the card reader associated with the electronic payment terminal 44.

At the completion of the initialization step 304, the routine 300 advances to an itemization step 306 where the customer enters the customer's individual items for purchase by scanning the items across the scanner 24. Moreover, in step 306, the customer may enter items, such as produce items or the like, by weighing the items with the product scale 26, and thereafter entering a product lookup code associated with the item via the touch screen associated with the display monitor 78a. Further, in step 306 the customer may enter an item by manually entering the product identification code associated with the item via use of the touch screen associated with the display monitor 78a. Such manual entry of an item may be necessary for items (which would otherwise be entered via the scanner 24) if the product identification code printed on the item is not readable by the scanner 24 or if the item is too large or bulky to be scanned with the scanner 24. It should be appreciated that the checkout system 10 may be configured such that the routine 300 allows more experienced customers to bypass the initialization step 304 thereby advancing directly to the itemization step 306. In such a configuration, the customer would begin the transaction by scanning or otherwise entering his or her first item for purchase.

At the completion of the itemization step 306, an end-of-itemization control signal is generated and the routine 300 advances to a finalization step 308 in which (1) a transaction receipt is printed by the receipt printer 54, (2) a record of the transaction is printed on the journal printer 88, and (3) payment is tendered by either inserting currency into the currency acceptors (i.e. the coin acceptor 46 and/or the bill acceptor 50), charging a credit card or debit card account or

decreasing a value amount stored on a smart card via the electronic payment terminal **44**. In the case of when a customer inserts currency into the coin acceptor **46** and/or the bill acceptor **50**, the checkout system **10** may provide change via a currency dispenser (i.e. the coin dispenser **48** and/or the bill dispenser **52**). After completion of the finalization step **308**, the routine **300** returns to step **302** in which the checkout system **10** remains in the idle condition until a subsequent customer initializes the system **10**.

During operation of the checkout system **10** in its self-service mode of operation, a number of software routines are executed to provide security from improprieties such as theft. For example, a scale security routine similar to the scale security routine **210** (see FIG. **26**) is executed in order to monitor the movement of items into and out of the post-scan area **18**. More specifically, during operation of the checkout system **10** in its self-service mode of operation, a scale security routine is executed which monitors (1) the movement of items into and out of the self-service bagwell **60**, and (2) onto and off of the set-aside item shelf **70** in order to reduce the number of occasions in which the customer commits an impropriety such as theft. Since the scale security routine executed when the checkout system **10** is being operated in its self-service mode of operation is somewhat similar to the scale security routine executed when the checkout system **10** is being operated in its assisted mode of operation, further discussion thereof is not warranted.

It should be appreciated that other security mechanisms may also be operated during operation of the checkout system **10** in its self-service mode of operation. For example, the security deactivation device **172** of the present invention is operated to generate a deactivation field in the form of a magnetic field or electromagnetic field during operation of the checkout system **10** in its self-service mode of operation so as to deactivate electronic tags associated with items for purchase as the items are scanned by the customer with the scanner **24**. In particular, as described above, the security deactivation device **172** generates a deactivation field (e.g. a magnetic and/or electromagnetic field) proximate to a scanner detection zone associated with the scanner **24**. By generating the deactivation field proximate to the scanner detection zone, a scanning motion utilized by the customer to scan an item with the scanner **24** causes the item to be advanced through the deactivation field thereby deactivating the electronic security tag secured to the item in the same scanning motion.

As described above, such utilization of the security deactivation device **172** is particularly useful when the checkout system **10** is being operated in its self-service mode of operation. In particular, by "automatically" deactivating the electronic security tag when the item is being scanned by a customer (i.e. deactivating the tag during a scanning motion), the customer is not required to perform additional operations for the sole purpose to deactivating the tag prior to exiting the store. In particular, heretofore designed self-service checkout systems have required the customer to take his or her items for purchase to a centralized area such as a terminal operated by a retail clerk after the customer has completed his or her transaction in order to allow the clerk to determine which of the customer's items contain electronic security tags that need to be deactivated. Thereafter, the clerk manually deactivates each of the electronic security tags associated with the customer's items for purchase. It should be appreciated that the extra step of requiring the customer to take his or her items to the centralized area to deactivate the electronic security tags adds cost to the retailer's operation (e.g. the cost associated with staffing the cen-

tralized area with a retail clerk) and also creates an inconvenience for the customer by requiring the customer to spend additional time in the retailer's store. Such an inconvenience to the customer is augmented if a line or queue is present at the centralized area.

Hence, utilization of the security deactivation device **172** of the present invention solves such shortcomings of heretofore self-service checkout systems by deactivating the electronic security tag as part of routine entry of items into the checkout system **10** by the customer. In particular, utilization of the security deactivation device **172** eliminates the need for the retail clerk to intervene into the customer's transaction thereby reducing labor costs associated with the retailer's operation, along with increasing convenience to the customer by not requiring him or her to stand in a potentially long line or queue. Moreover, by generating the deactivation field proximate to the scanner detection zone such that the electronic security tag is deactivated as a result of an item scanning motion, the customer is not required to operate a separate deactivation device such as a magnetic pad or the like thereby reducing the number of components that a customer is presented with during operation of the system **10**.

It should be appreciated that the security deactivation device **172** may be configured to continuously generate the deactivation field (e.g. the magnetic or electromagnetic field), or may only generate the deactivation field once the product code associated with the item has been captured by the scanner **24**. In particular, under the premise that if the customer is making an attempt to scan the item, the customer is likely not trying to commit an impropriety such as theft, the security deactivation device **172** may be configured to continuously generate the deactivation field such that the electronic security tag is deactivated whether or not the product code associated with the item is actually captured with the scanner **24**. For example, if the customer attempts to scan the item with the scanner **24** (by advancing the item through the scanner detection zone with the bar code associated with the item facing one of the scanning windows **24a**, **24b**), but the product code is not captured by the scanner for any reason, the security deactivation device **172**, if configured to continuously produce the deactivation field, may cause the electronic security label to be deactivated even though the item was not actually entered in the checkout system **10**. However, in the case of operation of the checkout system **10** by an honest customer, such premature deactivation of the security tag is not an issue once the customer is subsequently successful at entering the item (e.g. by re-scanning the item or manually entering the product code). It should be appreciated that the customer is likely to perform such re-scanning or manual entry of the item since the customer is not made aware of the fact that the electronic security tag has been deactivated.

However, to prevent the unlikely occurrence that the electronic security tag is prematurely deactivated and the item is not subsequently entered into the checkout system **10**, the security deactivation device **172** may be configured to generate the deactivation field only after the product code associated with the item has been entered into the system **10**. In particular, an item-entered control signal is generated when a product code associated with an item is captured by the scanner **24**. In response to generation of the item-entered control signal, the security deactivation device **172** may be instantaneously actuated so as to generate a deactivation field thereby deactivating the electronic security tag associated with the scanned item. In such a configuration, the location, width, and/or shape of the deactivation field generated by the security deactivation device **172** may be config-

ured to ensure that the item is advanced therethrough during a scanning motion or subsequent handling motion (e.g. the motion associated with placement of the item into the post-scan area 18).

Moreover, the video system 94 (see FIG. 9) may also be utilized to provide security from improprieties such as theft when the checkout system 10 is being operated in its self-service mode of operation. In particular, a video security routine similar to the video security routine 250 is executed, for example, at the end of the itemization step 306 (see FIG. 28), but prior to the beginning of the finalization step 308. As with the video security routine 250 utilized when the checkout system 10 is operated in its assisted mode of operation, the video security routine utilized when the checkout system 10 is being operated in its self-service mode of operation monitors video images captured by the video camera 94a in order to determine if the customers shopping receptacle (e.g. the shopping cart 238 or the shopping basket 240) is devoid of items (i.e. empty). Since the video security routine executed when the checkout system 10 is being operated in its self-service mode of operation is somewhat similar to the video security routine executed when the checkout system 10 is being operated in its assisted mode of operation, further discussion thereof is not warranted.

Moreover, the video camera 94a may also be operated to capture a video image of the customer operating the checkout system 10. In a known manner, the captured video image of the checkout clerk is then stored in the form of an electronic video file by the processing unit 78b. A subsequent video image (which is representative of the captured video image) may then be extracted from the electronic video file for use by the system 10. For example, an extracted video image of the customer (i.e. a video image extracted from the stored electronic file) may be displayed on the display monitor 78a of the interactive customer interface terminal 78 in order to serve as a psychological deterrent against theft or other improprieties. Moreover, the extracted video image of the customer may also be printed with the receipt printer 54 onto the customer's transaction receipt 96 (see FIG. 14) in order to serve as an additional psychological deterrent against theft or other improprieties.

As alluded to above, the status light device 84 and the paging device 86 may be utilized during operation of the checkout system 10 in its self-service mode of operation in order to page or otherwise summon retail personnel to the checkout system 10. In particular, if during operation of the checkout system 10 in its self-service mode of operation, an intervention-needed activity is detected, the status light device 84 and the paging device 86 are operated so as to summon retail personnel such as a customer service manager in order to assist and/or investigate the customer's operation of the system 10. As described in detail above, such an intervention-needed activity may take the form of a security-breach activity in which the checkout system 10 is being operated in a manner which is placing the retailer in a position of potential financial loss due to goods being taken from the store without having first been paid for (either intentionally or unintentionally). An intervention-needed activity may also take the form of a non-security-breach activity in which the customer is in need of assistance or the checkout system 10 is in need of maintenance, but the retailer is not at risk of financial loss due to goods being taken from the store without having first been paid for. For example, if the customer scanned a first item, but then placed a second item of greater value into a grocery bag as detected by, for example, the security scale 68, the processing unit 78b concludes that an intervention-needed activity has

occurred. Moreover, if the customer operating the system 10 touches a particular portion of the touch screen associated with the display monitor 78a, thereby indicating that he or she is in need of assistance, the processing unit 78b concludes that an intervention-needed activity has occurred.

In addition, the processing unit 78b may monitor the status of the retail peripheral devices associated with the checkout system 10 in order to determine if an intervention-needed activity has occurred. For example, the processing unit 78b preferably monitors the currency level within the coin dispenser 48 and the bill dispenser 52 in order to determine if either currency dispenser 48, 52 is in need of restocking. Moreover, the processing unit 78b preferably monitors the paper supply level within the receipt printer 54 and a journal printer 88 (see FIG. 9) in order to determine if either printer 54, 88 is in need of restocking. It should be appreciated that if any one of the currency dispensers 48, 52 or the printers 54, 88 is in need of restocking, the processing unit 78b concludes that an intervention-needed activity has occurred.

As described above, once an intervention-needed activity has been detected, the status light device 84 is operated to summon retail personnel. For example, the status light device 84 may display a first colored light (e.g. yellow) in order to notify retail personnel that intervention is needed prior to the end of the current checkout transaction. Alternatively, the status light device 84 may display a second colored light (e.g. red) in order to notify retail personnel that intervention is needed immediately.

As with the status light device 84, the paging device 86 is utilized to page or otherwise summon retail personnel to the checkout system 10 once an intervention-needed activity has been detected. The paging device 86 is particularly useful since it is operable to communicate with retail personnel who are positioned at locations within or outside of the store which are out of the view of the status light device 84. In particular, the signal transmitter 86a of the paging device 86 communicates with a number of portable communication devices such as wireless alphanumeric pagers 90. Hence, upon detection of an intervention-needed activity by the processing unit 78b, an intervention-needed control signal is generated. Upon generation of an intervention-needed control signal, the signal transmitter 86a generates an RF personnel-request signal which is received by the pagers 90. The personnel-request signal includes a specific alphanumeric message that includes such information as the nature of the intervention that is needed and the identity of the particular checkout system 10 that requires assistance. For example, if one of the currency dispensers 48, 52 needs to be restocked, the signal transmitter 86a generates an RF personnel-request signal which causes a message to be displayed on one of the pagers 90 which informs the customer service manager wearing the pager 90 that a particular checkout system 10 is, for example, running low on dimes.

Moreover, as shown in FIG. 22 and discussed above, the signal transmitter 86a may communicate with the signal receiver 92a associated with the intercom device 92 in order to generate audible messages which are broadcast to retail personnel within the store with the speakers 92b. In particular, upon detection of an intervention-needed activity by the processing unit 78b, an intervention-needed control signal is generated. Generation of an intervention-needed control signal causes the signal transmitter 86a to generate an RF personnel-request signal which is received by the signal receiver 92a associated with the intercom device 92. The personnel-request signal includes a specific code which corresponds to a number of specific, prerecorded audible mes-

sages stored in, or otherwise maintained by, the controller 92c of the intercom device 92. For example, each of the prerecorded messages may include such information as the nature of the intervention which is needed and the identity of the particular checkout system 10 which requires assistance. The controller 92c causes such prerecorded audible messages to be broadcast with the speakers 92b so as to be audibly detected by retail personnel such as a customer service manager within the retailer's store. For example, if one of the currency dispensers 48, 52 needs to be restocked, the signal transmitter 86a generates an RF personnel-request signal which, once received by the signal receiver 92a, causes an audible message to be broadcast on the speakers 92b which informs the customer service manager that a particular checkout system 10 is, for example, running low on dimes.

Additionally, during operation of the checkout system 10 in its self-service mode of operation, the display monitor 78a of the interactive customer interface may be utilized to display certain information to the customer while the customer is entering his or her items for purchase. For example, a customer-specific message such as a customer-specific advertisement which advertises a product that was purchased by the customer during a previous visit to the retailer's store may be displayed on the first portion 272 of the display monitor 78a, as shown in FIG. 21, while transaction information such as item description and price is displayed on the second portion 274 of the display monitor 78a. In particular, during a self-service checkout transaction, the processing unit 78b retrieves information from a customer profile database which contains customer-specific information (e.g. previous purchases) about each of the retailer's customers. Hence, as shown in FIG. 21, if the customer routinely purchases "ACME BEER", an advertisement for "ACME BEER" may be displayed on the first portion 272 of the display monitor 78a while the customer is entering the his or her items for purchase.

Moreover, such a customer-specific message may include a customer-specific advertisement which advertises a product which may be used in conjunction with a product which was previously scanned or otherwise entered into the checkout system 10 during the current checkout transaction. For example, if the customer scans a case of beer, an advertisement relating to pretzels may be displayed to the customer on the first portion 272 if the display monitor 78b since pretzels are commonly consumed with beer.

As described above in detail, the checkout system 10 of the present invention provides numerous advantages over heretofore designed checkout systems. For example, the checkout system 10 provides a low-cost, easy-to-operate checkout system that may be operated as either an assisted checkout system or a self-service checkout system. Moreover, the checkout system 10 of the present invention provides a checkout system that may be operated as either an assisted checkout system or a self-service checkout system that can be quickly and easily converted between the two types of systems. Yet further, the checkout system 10 of the present invention provides a checkout system that can be imported into numerous foreign countries with minimal effort during the importation process in regard to compliance of local electrical standards. In addition, the checkout system 10 of the present invention provides a checkout system has enhanced data and power cable routing management relative to heretofore designed checkout systems. Moreover, the checkout system 10 of the present invention provides a checkout system which may be constructed of "off the shelf", industry-standard retail peripheral devices thereby

substantially eliminating costs associated with development of proprietary data transmission and power architectures.

While the invention has been illustrated and described in detail in the drawings and foregoing description, such an illustration and description is to be considered as exemplary and not restrictive in character, it being understood that only the preferred embodiment has been shown and described and that all changes and modifications that come within the spirit of the invention are desired to be protected.

There are a plurality of advantages of the present invention arising from the various features of the checkout system described herein. It will be noted that alternative embodiments of the checkout system of the present invention may not include all of the features described yet still benefit from at least some of the advantages of such features. Those of ordinary skill in the art may readily devise their own implementations of a checkout system that incorporates one or more of the features of the present invention and fall within the spirit and scope of the present invention as defined by the appended claims.

What is claimed is:

1. A method of operating a retail terminal having a display monitor, comprising the steps of:

generating an item-entered control signal when an item for purchase is entered into said retail terminal;

displaying item information associated with said item for purchase on a first portion of said display monitor in response to generation of said item-entered control signal; and

displaying a customer-specific retail message on a second portion of said display monitor, wherein said step of displaying said customer-specific retail message is performed contemporaneously with said step of displaying said item information associated with said item for purchase.

2. The method of claim 1, wherein said step of displaying said customer-specific retail message includes the step of displaying said customer-specific retail message on said second portion of said display monitor based on identity of said item for purchase.

3. The method of claim 2, wherein said step of displaying said customer-specific retail message further includes the step of displaying a customer-specific advertisement on said second portion of said display monitor based on identity of said item for purchase.

4. The method of claim 1, wherein said step of displaying said item information associated with said item for purchase on said first portion of said display monitor includes the step of displaying a price associated with said item for purchase on said first portion of said display monitor.

5. The method of claim 1, wherein:

said step of generating said item-entered control signal when said item for purchase is entered into said retail terminal includes the step of generating said item-entered control signal when said item for purchase is entered into said retail terminal by retail personnel, and said step of displaying said customer-specific retail message on said second portion of said display monitor includes the step of displaying said customer-specific retail message to a customer on said second portion of said display monitor.

6. The method of claim 1, wherein:

said step of generating said item-entered control signal when said item for purchase is entered into said retail terminal includes the step of generating said item-entered control signal when said item for purchase is entered into said retail terminal by retail personnel, and



61

said step of displaying said customer-specific retail message on said second portion of said display monitor includes the step of displaying said customer-specific retail message to said retail personnel on said second portion of said display monitor.

7. A retail terminal, comprising:

a display monitor;

a processing unit electrically coupled to said display monitor; and

a memory device electrically coupled to said processing unit, wherein said memory device has stored therein a plurality of instructions which, when executed by said processing unit, causes said processing unit to:

(a) generate an item-entered control signal when an item for purchase is entered into said retail terminal,

(b) display item information associated with said item for purchase on a first portion of said display monitor in response to generation of said item-entered control signal, and

(c) display a customer-specific retail message on a second portion of said display monitor contemporaneously with display of said item information associated with said item for purchase on said first portion of said display monitor.

8. The retail terminal of claim 7, wherein said plurality of instructions, when executed by said processing unit, further causes said processing unit to display said customer-specific retail message on said second portion of said display monitor based on identity of said item for purchase.

9. The retail terminal of claim 8, wherein said plurality of instructions, when executed by said processing unit, further causes said processing unit to display a customer-specific advertisement on said second portion of said display monitor based on identity of said item for purchase.

10. The retail terminal of claim 7, wherein said plurality of instructions, when executed by said processing unit, further causes said processing unit to display a price associated with said item for purchase on said first portion of said display monitor.

11. The retail terminal of claim 7, wherein said plurality of instructions, when executed by said processing unit, further causes said processing unit to:

(a) generate said item-entered control signal when said item for purchase is entered into said retail terminal by retail personnel, and

(b) display said customer-specific retail message to said customer on said second portion of said display monitor.

12. The retail terminal of claim 7, wherein said plurality of instructions, when executed by said processing unit, further causes said processing unit to:

(a) generate said item-entered control signal when said item for purchase is entered into said retail terminal by retail personnel, and

(b) display said customer-specific retail message to said retail personnel on said second portion of said display monitor.

13. A method of operating a retail terminal having a display monitor, comprising the steps of:

generating an item-entered control signal when an item for purchase of a customer is entered into said retail terminal by retail personnel;

retrieving retail history information associated with said customer from a customer profile database;

displaying item information associated with said item for purchase on a first portion of said display monitor in response to generation of said item-entered control signal; and

62

displaying a customer-specific retail message based on said retail history information on a second portion of said display monitor, wherein said step of displaying said customer-specific retail message is performed contemporaneously with said step of displaying said item information associated with said item for purchase.

14. The method of claim 13, wherein said step of displaying said customer-specific retail message further includes the step of displaying a customer-specific advertisement on said second portion of said display monitor based on said retail information associated with the said customer.

15. The method of claim 13, wherein said step of displaying said item information associated with said item for purchase on said first portion of said display monitor includes the step of displaying a price associated with said item for purchase on said first portion of said display monitor.

16. The method of claim 13, wherein said step of displaying said customer-specific retail message on said second portion of said display monitor includes the step of displaying said customer-specific retail message to said customer on said second portion of said display monitor.

17. The method of claim 13, wherein said step of displaying said customer-specific retail message on said second portion of said display monitor includes the step of displaying said customer-specific retail message to said retail personnel on said second portion of said display monitor.

18. The method of claim 13, further comprising the step of reading a customer identity code from a customer card of said customer, wherein said retrieving step includes the step of retrieving said retail history information associated with said customer from said customer profile database based on said customer identity code.

19. A method of operating a retail terminal, comprising the steps of:

operating said retail terminal by retail personnel while said retail terminal is configured in an assisted mode of operation;

generating an item-entered control signal when an item for purchase is entered into said retail terminal;

displaying item information associated with said item for purchase on a first portion of a display monitor during said operating step in response to generation of said item-entered control signal; and

displaying a customer-specific retail message on a second portion of said display monitor during said operating step, wherein said step of displaying said customer-specific retail message is performed contemporaneously with said step of displaying said item information associated with said item for purchase.

20. The method of claim 19, wherein said retail terminal is configured to be convertible between an assisted mode of operation and a self-service mode of operation.

21. A method of operating an assisted retail terminal, comprising the steps of:

generating an item-entered control signal when an item for purchase is entered into said retail terminal;

displaying item information associated with said item for purchase on a first portion of a display monitor while said retail terminal is configured to be in an assisted mode of operation in response to generation of said item-entered control signal; and

displaying a customer-specific retail message on a second portion of said display monitor while said retail terminal is configured to be in an assisted mode of operation, wherein said step of displaying said customer-specific retail message is performed contemporaneously with

63

said step of displaying said item information associated with said item for purchase.

22. The method of claim 21, wherein said retail terminal is configured to be convertible between an assisted mode of operation and a self-service mode of operation.

23. The method of claim 1, wherein said item for purchase is entered into said retail terminal in response to a scanner reading a product identification code associated with said item for purchase.

24. The retail terminal of claim 7, wherein said item for purchase is entered into said retail terminal in response to a scanner reading a product identification code associated with said item for purchase.

25. The method of claim 13, wherein said item for purchase is entered into said retail terminal in response to a scanner reading a product identification code associated with said item for purchase.

26. A method of operating a retail terminal having a display monitor, in a self-service checkout transaction, comprising the steps of: scanning an item for purchase into said retail terminal; displaying item information associated with said item for purchase on said display monitor in response to scanning said item; and displaying a customer-specific retail message on said display monitor, contemporaneously with displaying said item information, the customer-specific retail message being based on previous purchase information stored in a customer profile.

27. A method of operating a retail terminal having a display monitor, in a self-service checkout transaction, comprising the steps of: scanning an item for purchase into said retail terminal by a self-service customer, displaying item information including an item price and an item description associated with said item for purchase on said display monitor in response to scanning said item; and displaying a retail message on said display monitor, contemporaneously with displaying said item information, where the retail message is customized based on said item for purchase scanned into the terminal by the customer during the current transaction.

28. A method of operating a retail terminal having a display monitor, in a self-service checkout transaction, comprising the steps of: entering an item for purchase by a self-service customer into said retail terminal; displaying item information associated with said item for purchase on said display monitor in response to entering said item; and displaying a customer-specific retail message on said display monitor, contemporaneously with displaying said item information, the customer-specific retail message being based on previous purchase information stored in a customer profile.

29. A method of operating a retail terminal having a display monitor, in a self-service checkout transaction, comprising the steps of: entering an item for purchase into said retail terminal; displaying item information including an item price and an item description associated with said item for purchase on said display monitor in response to entering said item; and displaying a retail message on said display monitor, contemporaneously with displaying said item information, where the retail message is customized based on a product entered into the terminal during the current transaction by a self-service customer.

30. A method of operating a retail terminal having a display monitor, in a self-service checkout transaction, comprising the steps of: entering an item for purchase into said retail terminal by a self-service customer; displaying item information associated with said item for purchase on said display monitor in response to entering said item; and displaying a retail message on said display monitor, contemporaneously with displaying said item information, where the retail message is customized based on a product that can be used in conjunction with said item for purchase entered during the current transaction.

64

reaneously with displaying said item information, where the retail message is customized based on a product that can be used in conjunction with said item for purchase entered during the current transaction.

31. The method of claim 30 in which said item for purchase is a case of beer and said retail message is an advertisement for pretzels which are commonly consumed with beer.

32. A method of operating a retail terminal having a display monitor, in a self-service checkout transaction, comprising the steps of: entering an item for purchase into said retail terminal by a self-service customer; displaying item information including an item price and an item description associated with said item for purchase on said display monitor in response to entering said item; and displaying a retail message on said display monitor, contemporaneously with displaying said item information, where the retail message is customized based on said item for purchase entered into the terminal during the current transaction by the customer.

33. A method of operating a retail terminal having a display monitor, in a self-service checkout transaction, comprising the steps of: entering an item for purchase by a self-service customer into said retail terminal; displaying item information associated with said item for purchase on said display monitor in response to entering said item; and displaying a retail message on said display monitor, contemporaneously with displaying said item information, where the retail message is an advertisement which advertises a product that was purchased by the customer during a previous transaction, the retail message being based on previous purchase information stored in a customer profile.

34. A method of operating a retail terminal having a display monitor, in an assisted checkout transaction, comprising the steps of: entering an item for purchase by a customer into said retail terminal; displaying item information associated with said item for purchase on said display monitor in response to entering said item; and displaying a retail message on said display monitor, contemporaneously with displaying said item information, where the retail message is an advertisement which advertises a product that was purchased by the customer during a previous transaction, the retail message, being based on previous purchase information stored in a customer profile.

35. A method of operating a retail terminal having a display monitor, in an assisted checkout transaction, comprising the steps of: entering an item for purchase by a customer into said retail terminal; displaying item information associated with said item for purchase on said display monitor in response to entering said item; and displaying a retail message on said display monitor, contemporaneously with displaying said item information, where the retail message is a customer-specific message that may be viewed on said display monitor by a checkout clerk, the retail message being based on information stored in a customer-profile, associated with an identified customer, the customer profile including customer-specific information for the customer, the customer-specific information including customer purchase history for the customer.

36. A method of operating a retail terminal having a display monitor, in an assisted checkout transaction, comprising the steps of: entering an item for purchase by a customer into said retail terminal; displaying item information associated with said item for purchase on said display monitor in response to entering said item; and displaying a retail message on said display monitor, contemporaneously with displaying said item information, where the retail message informs a checkout clerk that the customer is not old enough to purchase beer or other type of alcohol.

65

37. A method of operating a retail terminal having a display monitor, in an assisted checkout transaction, comprising the steps of: entering an item for purchase by a customer into said retail terminal; displaying item information associated with said item for purchase on said display monitor in response to entering said item; and displaying a customer-specific retail message on said display monitor, contemporaneously with displaying said item information, in order for the message to be verbally relayed or otherwise communicated to the customer by a checkout clerk, the customer-specific retail message being based on previous purchase information stored in a customer profile.

38. A retail terminal, comprising: a display monitor; a processing unit electrically coupled to said display monitor, and a memory device electrically coupled to said processing unit, wherein said memory device has stored therein a plurality of instructions which, when executed by said processing unit in a self-service checkout transaction, causes said processing unit to: (a) enter an item for purchase scanned into said retail terminal, (b) display item information associated with said item for purchase on said display monitor in response to said item for purchase being entered, and (c) display a customer-specific retail message on said display monitor contemporaneously with said display of said item information associated with said item for purchase, the customer-specific retail message being based on previous purchase information stored in a customer profile.

39. A retail terminal, comprising: a display monitor; a processing unit electrically coupled to said display monitor; a memory device electrically coupled to said processing unit, wherein said memory device has stored therein a plurality of instructions which, when executed by said processing unit in a self-service checkout transaction, causes said processing unit to: (a) enter an item for purchase scanned into said retail terminal by a self-service customer, (b) display item information including an item price and an item description associated with said item for purchase on said display monitor in response to said item for purchase being entered, and (c) display a retail message on said display monitor retail messages into the terminal, contemporaneously with said display of said item information, where the retail message is customized based on said item for purchase entered by the customer during the current transaction.

40. A retail terminal, comprising: a display monitor; a processing unit electrically coupled to said display monitor; and a memory device electrically coupled to said processing unit, wherein said memory device has stored therein a plurality of instructions which, when executed by said processing unit in a self-service checkout transaction, causes said processing unit to: (a) enter an item for purchase by a self-service customer into said retail terminal, (b) display item information associated with said item for purchase on said display monitor in response to said item for purchase being entered, and (c) display a customer-specific retail message on said display monitor, contemporaneously with said display of said item information, the customer-specific retail message being based on previous purchase information stored in a customer profile associated with an identified customer.

41. A retail terminal, comprising: a display monitor; a processing unit electrically coupled to said display monitor; and a memory device electrically coupled to said processing unit, wherein said memory device has stored therein a plurality of instructions which, when executed by said processing unit in a self-service checkout transaction, causes said processing unit to: (a) enter an item for purchase by a self-service customer into said retail terminal, (b) display item

66

information including an item price and an item description associated with said item for purchase on said display monitor in response to said item for purchase being entered, and (e) display a retail message on said display monitor, contemporaneously with said display of said item information, where the retail message is customized based on the nature of said item for purchase entered into the terminal by the customer during the current transaction.

42. A retail terminal, comprising: a display monitor; a processing unit electrically coupled to said display monitor; and a memory device electrically coupled to said processing unit, wherein said memory device has stored therein a plurality of instructions which, when executed by said processing unit in a self-service checkout transaction, causes said processing unit to: (a) enter an item for purchase by a self-service customer into said retail terminal, (b) display item information including an item price and an item description associated with said item for purchase on said display monitor in response to said item for purchase being entered, and (c) display a retail message on said display monitor, contemporaneously with said display of said item information, where the retail message is customized based on a product that can be used in conjunction with said item for purchase entered by the customer.

43. The terminal of claim 42 in which said item for purchase in a case of beer and said retail message is an advertisement for pretzels which are commonly consumed with beer.

44. A retail terminal, comprising: a display monitor; a processing unit electrically coupled to said display monitor; and a memory device electrically coupled to said processing unit, wherein said memory device has stored therein a plurality of instructions which, when executed by said processing unit in a self-service checkout transaction, causes said processing unit to: (a) enter an item for purchase by a self-service customer into said retail terminal, (b) display item information including an item price and an item description associated with said item for purchase on said display monitor in response to said item for purchase being entered, and (c) display a retail message on said display monitor, contemporaneously with said display of said item information, where the retail message is customized based on said item for purchase entered into the terminal by the customer during the current transaction.

45. A retail terminal, comprising: a display monitor; a processing unit electrically coupled to said display monitor; and a memory device electrically coupled to said processing unit, wherein said memory device has stored therein a plurality of instructions which, when executed by said processing unit in a self-service checkout transaction, causes said processing unit to: (a) enter an item for purchase by a self-service customer into said retail terminal; (b) display item information associated with said item for purchase on said display monitor in response to said item for purchase being entered, and (c) display a retail message on said display monitor, contemporaneously with said display of said item information, where the retail message is an advertisement which advertises a product that was purchased by the customer during a previous transaction, the retail message being based on previous purchase information stored in a customer profile associated with an identified customer.

46. A retail terminal, comprising: a display monitor; a processing unit electrically coupled to said display monitor; and a memory device electrically coupled to said processing unit, wherein said memory device has stored therein a plurality of instructions which, when executed by said processing unit in an assisted checkout transaction, causes said

67

processing unit to: (a) enter an item for purchase into said retail terminal, (b) display item information associated with said item for monitor in response to said item for purchase being entered, and (c) display a retail message on said display monitor, contemporaneously with said display of said item information, where the retail message is advertisement which advertises a product that was purchased by the customer during a previous transaction, the retail message being based on previous purchase information stored in a customer profile associated with an identified customer.

47. A retail terminal, comprising: a display monitor; a processing unit electrically coupled to said display monitor; and a memory device electrically coupled to said processing unit, wherein said memory device has stored therein a plurality of instructions which, when executed by said processing unit in an assisted checkout transaction, causes said processing unit to: (a) enter an item for purchase into said retail terminal, (b) display item information associated with said item for purchase on said display monitor in response to said item for purchase being entered, and (c) display a retail message on said display monitor, contemporaneously with said display of said item information, where the retail message is a customer-specific message that may be viewed by a checkout clerk the customer-specific message being based on previous purchase information stored in a customer profile associated with an identified customer.

48. A retail terminal, comprising: a display monitor; a processing unit electrically coupled to said display monitor; and a memory device electrically coupled to said processing unit, wherein said memory device has stored therein a plurality of instructions which, when executed by said processing unit in an assisted checkout transaction, causes said processing unit to: (a) enter an item for purchase by a customer into said retail terminal, (b) display item information associated with said item for purchase on said display monitor in response to said item for purchase being entered, and (c) display a retail message on said display monitor, contemporaneously with said display of said item information, where the retail message informs a checkout clerk that the customer is not old enough to purchase the beer or other type of alcohol.

49. A retail terminal, comprising: a display monitor; a processing unit electrically coupled to said display monitor; and a memory device electrically coupled to said processing unit, wherein said memory device has stored therein a plurality of instructions which, when executed by said processing unit in an assisted checkout transaction, causes said processing unit to: (a) enter an item for purchase by a customer into said retail terminal, (b) display item information associated with said item for purchase on said display monitor in response to said item for purchase being entered, and (c) display a customer-specific retail message on said display monitor, contemporaneously with said display of said

68

item information, in order for the message to be verbally relayed or otherwise communicated to the customer by a checkout clerk, the customer-specific retail message being based on previous purchase information stored in a customer profile associated with an identified customer.

50. A method of operating a retail terminal having a display monitor, in a self-service checkout transaction, comprising the steps of: identifying a self-service customer by reading a loyalty card using a card reader associated with said retail terminal to obtain customer identifying information; scanning an item for purchase into said retail terminal by the self-service customer, displaying item information associated with said item for purchase on said display monitor in response to scanning said item; and displaying a retail message on said display monitor, contemporaneously with displaying said item information, where the message is generated using the customer identifying information, as an index to retrieve previous purchase information from a stored customer profile associated with the customer.

51. The method of claim 50 in which the customer information is read from the customer's said loyalty card and automatically entered into said retail terminal.

52. A method of operating a retail terminal having a display monitor, in a self-service checkout transaction, comprising the steps of: instructing a self-service customer to identify himself or herself by reading a loyalty card using a card reader associated with said retail terminal scanning an item for purchase into said retail terminal by the self-service customer; displaying item information including an item price and an item description associated with said item for purchase on said display monitor in response to scanning said item; and displaying a retail message on said display monitor, contemporaneously with displaying said item information, where the message is generated using information collected when the customer applies or otherwise registers for the loyalty card, the collected information being stored in a customer profile associated with the customer.

53. A method of operating a retail terminal having a display monitor, in a self-service checkout transaction, comprising the steps of: instructing a self-service customer to identify himself or herself by reading a loyalty card using a card reader associated with said retail terminal; scanning an item for purchase into said retail terminal by the self-service customer; displaying item information including an item price and an item description associated with said item for purchase on said display monitor in response to scanning said item; and displaying a retail message on said display monitor, contemporaneously with displaying said item information, where the retail message is generated based on said item for purchase scanned into the terminal by the customer during the current transaction.

\* \* \* \* \*