

(19) World Intellectual Property Organization  
International Bureau



(43) International Publication Date  
18 January 2001 (18.01.2001)

PCT

(10) International Publication Number  
WO 01/04461 A1

- (51) International Patent Classification<sup>7</sup>: E21B 47/12, F17D 5/06
- (74) Agents: FAULKNER, Thomas, John et al.; fJ Cleveland, 40-43 Chancery Lane, London WC2A 1JQ (GB).
- (21) International Application Number: PCT/GB00/02538
- (22) International Filing Date: 30 June 2000 (30.06.2000)
- (25) Filing Language: English
- (26) Publication Language: English
- (30) Priority Data:  
9915968.3 7 July 1999 (07.07.1999) GB  
9924027.7 11 October 1999 (11.10.1999) GB
- (71) Applicant (for all designated States except US): FLIGHT REFUELLING LIMITED [GB/GB]; Brook Road, Wimborne, Dorset BH21 2BJ (GB).
- (81) Designated States (national): AE, AG, AL, AM, AT, AU, AZ, BA, BB, BG, BR, BY, BZ, CA, CH, CN, CR, CU, CZ, DE, DK, DM, DZ, EE, ES, FI, GB, GD, GE, GH, GM, HR, HU, ID, IL, IN, IS, JP, KE, KG, KP, KR, KZ, LC, LK, LR, LS, LT, LU, LV, MA, MD, MG, MK, MN, MW, MX, MZ, NO, NZ, PL, PT, RO, RU, SD, SE, SG, SI, SK, SL, TJ, TM, TR, TT, TZ, UA, UG, US, UZ, VN, YU, ZA, ZW.
- (84) Designated States (regional): ARIPO patent (GH, GM, KE, LS, MW, MZ, SD, SL, SZ, TZ, UG, ZW), Eurasian patent (AM, AZ, BY, KG, KZ, MD, RU, TJ, TM), European patent (AT, BE, CH, CY, DE, DK, ES, FI, FR, GB, GR, IE, IT, LU, MC, NL, PT, SE), OAPI patent (BF, BJ, CF, CG, CI, CM, GA, GN, GW, ML, MR, NE, SN, TD, TG).

- (72) Inventors; and  
(75) Inventors/Applicants (for US only): HUDSON, Steven, Martin [GB/GB]; Frekes Cottage, Moorside, Sturminster Newton, Dorset DT10 1HQ (GB). JOINSON, Daniel [GB/GB]; 12 Finchdale Close, Carterton, Oxon OX18 3BT (GB).

**Published:**

— With international search report.

For two-letter codes and other abbreviations, refer to the "Guidance Notes on Codes and Abbreviations" appearing at the beginning of each regular issue of the PCT Gazette.

(54) Title: DATA TRANSMISSION IN PIPELINE SYSTEMS

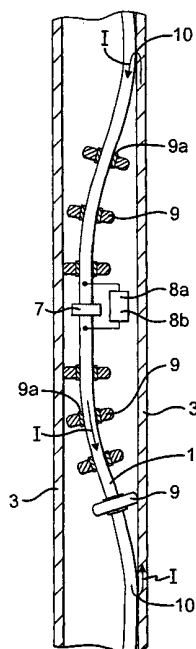

(57) Abstract: A first set of apparatus is arranged for transmitting data from a point in a cased section of a well (1, 3) to a remote location. The apparatus may be used as a relay station (6) to increase operational depth. Signals are applied to and received from the string (1) at the relay station (6) and a selected length of the string (1) is provided with insulating spacer means (9) on either side of the relay station to ensure that the string (1) and casing (3) are effectively isolated for a selected minimum distance. This enables potential differences to be both applied to and detected from the string (1), thus allowing data transmission and reception. A second set of apparatus (figure 8) is arranged for transmitting from an internal unit (408) inside a cased section of the well (401, 403) to the immediate surrounding area outside the casing (403). The internal unit (408) injects current into the string (401). A toroid (415) which surrounds the casing (403) is provided to pick up signals. Spaced connections between the string (401) and casing (403) are provided by conductive packers (411). A mismatch in the current flowing in the string (401) and casing (403) is generated so that a non-zero flux is seen by the toroid and hence a signal can be received.

WO 01/04461 A1

### Data transmission in pipeline systems

This invention relates to data transmission systems, methods of data transmission, signal receiving apparatus and methods of receiving signals all for use in pipeline systems, in particular wells.

It is useful to be able to take measurements when drilling for oil and gas and during the operation of producing wells. However, it is difficult to transmit data from downhole locations to the surface and the difficulty increases with depth. At present there is a requirement for data transmission from 3000 metres or more below the surface.

Of the signalling techniques currently available those which make use of the metallic structure of the well itself are particularly preferred as they remove the need to install separate wirelines. Most non-wireline systems make use of the production string and casing as a single conducting channel and use earth as the return path. Some attempts have been made to use the casing and string as separate conduction paths but this is fraught with problems because of the difficulties in isolating the string from the casing throughout its length and in particular at the wellhead because of the loads involved. Other methods include "mud-pulsing" which is not only difficult to implement and expensive but also gives a poor data rate.

Whichever system is used, the range is limited because of the inherent losses involved and the need to keep currents at reasonable levels. Further, to the applicant's knowledge no practical non-wireline systems are currently available for signalling from locations on the string within the casing. The communication system

described in the applicant's earlier application EP-A-0,646,304, for example, works in open hole conditions and can transmit a signal along a cased section. However it is generally accepted that such a system cannot be used  
5 in practice to transmit from a position within a cased section.

In pipeline systems it is also desirable to be able to transmit signals from an apparatus within a flowline and/or the associated casing to an apparatus in the same  
10 region of the system but outside the flowline and/or casing. However, it is generally accepted that this is difficult to achieve.

It is an object of the present invention to provide communications systems which alleviate at least some of  
15 the problems associated with the prior art.

According to a first aspect of the present invention there is provided a data transmission system in which metallic structure of a pipeline system is used as a signal channel and earth is used as return comprising  
20 means for forming a current loop path having first and second conducting portions electrically connected to one another at spaced locations, the metallic structure comprising at least one of the conducting portions, and a local unit having transmitting means for applying a  
25 signal to one of the conducting portions whereby in use current flows around said loop generating a potential difference between earth and the metallic structure in the region of the loop and causing a signal to be propagated along the metallic structure away from the  
30 loop, wherein the means for forming the current loop path is arranged to ensure that the spaced locations are separated by at least a minimum distance selected to give desired transmission characteristics.

According to a second aspect of the present invention there is provided a method of data transmission in which metallic structure of a pipeline system is used as a signal channel and earth is used as return comprising the steps of:

5 forming a current loop path having first and second conducting portions electrically connected to one another at spaced locations, the metallic structure comprising at least one of the conducting portions;

10 applying a signal to one of the conducting portions to cause a current to flow around said loop to generate a potential difference between earth and the metallic structure in the region of the loop and cause a signal to be propagated along the metallic structure away from

15 the loop; and

ensuring that the spaced locations are separated by at least a minimum distance selected to give desired transmission characteristics.

The pipeline system may comprise an inner flow line and a surrounding casing. Typically the pipeline system comprises a well having a production string and surrounding casing.

The current flowing around the loop path in operation can be considered to make the system act as a dipole transmitter.

Receiving means may be provided at a location remote from said current loop path for receiving the signals propagated along the metallic structure.

The above arrangement has the advantages that wirelines can be avoided and a signal which will be detectable can be injected onto the metallic structure in practical situations using realistic current levels even when signalling along a production string from a

position in which the string is located within a casing. Away from the region of the current loop path, the metallic structure as whole may be treated as a single conduction channel.

5           The minimum distance can be chosen to suit the circumstances such that an acceptable level of signal is detectable at the desired location remote from the local unit, for example at the well head. A typical selected minimum distance may be 100 metres. It is preferred that  
10 the selected minimum distance is small relative to the overall length of the structure/well.

          Preferably one of the conducting portions comprises a portion of a production string. The transmitting means may be arranged to apply signals to the production  
15 string.

          In some embodiments one conducting portion comprises a portion of a flow line, for example a production string and the other conducting portion comprises a surrounding portion of casing. In such embodiments the means for  
20 forming a current loop path may comprise insulating spacer means for keeping the flow line spaced from the surrounding casing for the selected minimum distance. An insulating coating may be provided on the flow line and/or casing over the portion corresponding to the  
25 selected minimum distance. The spaced connections between the first and second conducting portions to complete the current loop path may comprise glancing contacts between the flow line and casing beyond the selected region. It will be appreciated that the costs involved in improving  
30 isolation between the flow line and casing over the selected minimum distance will be significantly lower than those involved in trying to isolate the string and casing along their whole length.

In other embodiments one conducting portion comprises a portion of a pipeline or flowline and the other conducting portion comprises at least one electrically conductive elongate member connecting at least two pigs disposed within the pipeline or flowline. In such embodiments the spaced connections to complete the current loop path may be provided at the pigs. The local unit may be provided at one of the pigs. Preferably the transmitting means is arranged to apply signals to the elongate member.

The local unit may comprise sensor means for measuring conditions in the region of the unit. The local unit may comprise receiving means for receiving incoming signals transmitted along the metallic structure or otherwise. The local unit may be arranged to act as a relay station. It will be appreciated that the relay station may be disposed on a cased section of production string and thus be used to improve the range of the data transmission system.

Preferably the transmitting means applies signals substantially at the midpoint of the respective conducting portion. This tends to equalise the signal propagation characteristics away from the local unit in both directions along the metallic structure and is particularly suitable if the local unit is to function as a bi-directional relay station.

On the other hand, if it is desired to increase the signal transmission in one direction, the transmitting means may be arranged to apply signals at a point towards one end, preferably the opposite end, of the respective conducting portion.

The transmitting means and/or the receiving means may comprise an isolation member disposed in series with

the respective conducting portion. The transmitting means may comprise a signal generating means connected across the isolation member. The receiving means may comprise a signal measuring means, for example voltage measuring means, connected across the isolation member. Where the  
5 respective conducting portion comprises the production string the isolation member may be an isolation joint disposed in the string.

The transmitting means and/or the receiving means  
10 may comprise inductive coupling means disposed around the respective conducting portion. The current loop path may act as a single turn winding of a transformer. The inductive coupling means may comprise a coil wound on a generally toroidal core which encircles the respective  
15 conducting portion.

According to a third aspect of the present invention there is provided signal receiving apparatus for use with a data transmission system in which metallic structure of a pipeline system is used as a signal channel and  
20 earth is used as return, comprising a local unit having receiving means, means for providing electrical contact between the local unit and at least two spaced locations on a portion of the metallic structure and means for ensuring that the two spaced locations are separated by  
25 at least a minimum distance selected to give desired reception characteristics.

According to a fourth aspect of the present invention there is provided a method for receiving a signal from the metallic structure of a pipeline system  
30 which is used as a signal channel in a data transmission system with earth as return, comprising the steps of providing a local unit having receiving means; providing electrical contact between the local unit and at least

two spaced locations on a portion of the metallic structure; and ensuring that the spaced locations are separated by at least a minimum distance selected such to give desired reception characteristics.

5           When a signal is transmitted along the metallic structure of a pipeline system the magnitude of the signal generally decreases as distance from the signal source is increased. This is mainly due to the gradual leakage to earth of the signal. Thus when a signal is  
10 travelling along the metallic structure there is a potential difference between any two longitudinally spaced points and it has been appreciated that providing a connection to two such points enables a signal to be extracted from the metallic structure. The minimum  
15 distance required depends on the signal level with respect to earth at the locations concerned and the sensitivity/noise performance of the receiving means.

          The means for providing electrical contact at spaced locations may comprise a portion of the production string  
20 and insulating spacer means provided to keep said string portion spaced from the corresponding portion of surrounding casing. An isolation joint may be provided in the string in the region of the local unit and a signal measuring means connected across it. In this case,  
25 because the string is effectively isolated from the casing, all of the signal losses for that section of the metallic structure will be from the casing and there will be little potential drop along that portion of the string so that the potential difference between the spaced  
30 locations can be detected.

          The means for providing electrical contact at spaced locations may comprise at least one electrically conductive elongate member connecting at least two pigs



disposed within the production string.

According to a fifth aspect of the present invention there is provided signal receiving apparatus for use with a data transmission system in which metallic structure  
5 of a pipeline system is used as a signal channel, comprising a local unit having receiving means which comprises an inductive coupling.

The signal channel may be split into two or more branches in the region of the local unit and the  
10 inductive coupling disposed around one of said branches.

Preferably the inductive coupling is disposed around a production string disposed within a casing. One branch may comprise the production string and another branch may comprise the casing.

15 The inductive coupling may comprise a toroid disposed around said one of the channels and/or a production string.

According to a further aspect of the present invention there is provided a data transmission system  
20 in which metallic structure of a well including a production string and casing is used as a signal channel and earth is used as return comprising a local unit having receiving and/or transmitting means coupled to the string for receiving signals from and/or transmitting  
25 signals along the signal channel and insulating spacer means arranged to ensure that the production string and casing are spaced from one another for at least a selected minimum distance in the region of the local unit, said minimum distance being selected to give  
30 desired reception and/or transmission characteristics.

The casing may comprise a plurality of separate sections, which may be screwed together. Mating surfaces at one or more joint between adjacent sections may be

coated with an isolating medium. This can change the electrical characteristics of the metal structure and enhance performance.

Many of the additional features described following the earlier aspects of the invention are equally  
5 appropriate for use in conjunction with said further aspect of the invention.

According to another aspect of the invention there is provided a data transmission system for use in  
10 pipeline systems which comprises,  
means for forming a current loop path comprising a portion of an inner conductive member and a corresponding portion of an outer conductive member electrically  
connected to one another at two spaced locations, the  
15 outer conducting member surrounding the inner conductive member and being part of the metallic structure of a pipeline system;  
an internal unit disposed within the outer member and having transmission means for injecting a signal into the  
20 current loop path; and  
an external unit disposed outside the outer member comprising inductive coupling means arranged to be linked by flux generated by current flowing around the loop  
path,  
25 the arrangement being such that in use the current flowing in said portion of the inner member does not match the current flowing in the corresponding portion of the outer member whereby signals are generated in the inductive coupling means so allowing communication from  
30 the internal unit to the external unit.

According to yet another aspect of the present invention there is provided a method of data transmission system for use in pipeline systems which comprises the

steps of: forming a current loop path comprising a portion of an inner conductive member and a corresponding portion of an outer conductive member electrically connected to one another at two spaced locations, the  
5 outer conducting member surrounding the inner conductive member and being part of the metallic structure of a pipeline system;

injecting a signal into the current loop path from an internal unit disposed within the outer member; and  
10 disposing an external unit outside the outer member which unit comprises inductive coupling means arranged to be linked by flux generated by current flowing around the loop path,

and the arrangement being such that in use the current  
15 flowing in said portion of the inner member does not match the current flowing in the corresponding portion of the outer member whereby signals are generated in the inductive coupling means so allowing communication from the internal unit to the external unit.

20 Generally the inner and outer members will be generally co-axially arranged elongate members, the outer member being generally tubular.

The spaced locations may be separated by a selected minimum distance. Preferably the minimum distance is  
25 selected to give desired transmission characteristics.

In some embodiments, the data transmission system may be arranged for use in pipeline systems comprising a conductive flowline which acts as the outer member and a dedicated inner conductive member may be provided. In  
30 such a case the inner conductive member may comprise a conductive strop connected between two pigs.

The electrical connections between the dedicated inner conductor and a flow line may be provided at the pigs.

Cleaning brushes located on the pigs may act as contacts with the inner surface of the flowline.

In other embodiments, the data transmission system may be arranged for use in pipeline systems comprising  
5 an inner conductive flowline and an outer conductive casing. In such a case the outer member may comprise the casing and the inner member may comprise the flowline.

The outer member, particularly when a casing, may comprise a plurality of separate sections, which may be  
10 screwed together. Mating surfaces at one or more joint between adjacent sections may be coated with an isolating medium. This can change the electrical characteristics of the metal structure and enhance performance. It is preferred that no completely isolated joint is disposed  
15 in the casing between the spaced locations at which the casing and flowline electrically contact one another.

The electrical connections between the flowline and casing may comprise glancing contacts and/or conductive packers. Where the spaced connections consist of glancing  
20 contacts it is possible to select a minimum separation between the connections. Where conductive packers are used the actual spacing between the packers, and hence the connections, may be chosen. The means for forming the current loop path may comprise an insulating layer  
25 provided on the outer surface of the inner flow line and/or the inner surface of the outer casing. The means for forming the current loop path may comprise insulating spacer means.

The positions and/or nature of the connections  
30 and/or means used for insulating the portion of the flowline from the corresponding portion of the casing may be chosen to give desired transmission characteristics.

Preferably the transmission means is arranged to

apply signals to the inner flowline. An isolation joint may be provided in the flowline and the transmission means may be arranged to signal across the isolation joint.

5       The inductive coupling means may comprise a toroid disposed around the casing in the region of the current loop. Preferably the inductive coupling means is disposed towards a midpoint between the spaced connections.

10       Typically the pipeline system comprises a cased section of a well, the production string being the flowline in such a case.

15       According to yet another aspect of the present invention there is provided apparatus for use with a metallic structure in carrying out any one of the above aspects of the invention.

Embodiments of the present invention will now be described by way of example only with reference to the accompanying drawings in which:

20       Figure 1 schematically shows a subsea well including a data transmission system which comprises a first embodiment of the invention;

Figure 2 schematically shows a portion of the well shown in Figure 1 at which a relay station is disposed;

25       Figure 3 shows a simplified equivalent circuit of a typical length of production string and casing of the well shown in Figure 1;

Figure 4 shows a simplified equivalent circuit of the portion of the well shown in Figure 2 during reception of a signal;

30       Figure 5 shows a simplified equivalent circuit of the portion of the well shown in Figure 2 during transmission of a signal;

Figure 6 shows an alternative coupling method;

Figure 7 is a schematic view of part of a second embodiment of the invention;

Figure 8 schematically shows a third embodiment of the present invention; and

5 Figure 9 shows an equivalent circuit for the arrangement shown in Figure 8.

Figures 1 and 2 schematically show a subsea well including a wireless or non-wireline data transmission system. The well comprises a production string 1 for  
10 extracting product from a formation F. The production string 1 joins a tree 2 at the mudline and is surrounded by casing 3 between the tree 2 and the formation F. The string 1 and casing 3 form part of the metallic structure of the well. Although Figure 1 shows the string 1 as  
15 being disposed centrally within the casing 3, in practice the string 1 and casing 3 will make glancing contact with one another at numerous positions along their lengths. In general there is nothing to prevent such glancing contact and the string 1 will follow a sinuous, for  
20 example a helical, path within the casing 3.

The space between the string 1 and casing 3 is filled with brine (or alternatively another fluid which is denser than water) to help reduce the pressure acting on the packing ring 4 provided between the casing 3 and  
25 string 1 as they enter the formation F. The presence of the brine introduces a further conduction path between the string 1 and the casing 3.

The effect of the glancing contacts and conduction through the brine mean that in general corresponding  
30 points of the string 1 and casing 3 will reach the same potential and the string 1 and casing 3 must be treated as a single conductor.

The well also comprises a number of data logging

stations 5 provided on the string 1 at open well locations, that is within the formation. The data transmission system is arranged to allow data to be transmitted between the data logging stations 5 and the mudline or beyond by using the metallic structure of the well 1,3 as a signal channel. The distance between the data logging stations and the mudline may be in excess of 3000 metres. Data is received at and transmitted from the data logging stations 5 using existing non-wireline open well techniques, for example those described in the applicant's earlier application EP-A-0,646,304. Whilst these techniques work in the open well and can transmit a signal along the cased section they cannot be used in practice to transmit from a position within the cased section. Only if the length of the cased section is not too great can signals be received directly at and sent directly from the mudline using the non-wireline techniques described in the above mentioned application; range and data rate being essentially determined by signal to noise ratio.

In the present embodiment however, the strength of the signal and/or range of the system is improved by providing a relay station 6 partway along the cased portion of the production string 1. Referring particularly to Figure 2, the relay station 6 comprises transceiver means including an isolation joint 7 provided in the production string, signal generating means 8a used during transmission and signal measuring means 8b used during reception. Both the signal generating means and the signal measuring means are connected across the isolation joint 7. A plurality of insulating annular spacers 9 are provided around the production string 1 over a distance of the order of 100 metres in the region

of the isolation joint 7. The distance over which the spacers 9 are provided is chosen such that signals can be effectively received and transmitted. The actual distance will depend on a number of factors relating to the components of the transmission system and the well itself.

The spacers 9 are of a half shell type which are bolted together around the string 1. An insulating layer 9a is provided between each spacer and the string 1. In Figure 2, a side view of one of the spacers 9 is shown and the remainder of the spacers 9 are shown in cross-section. The spacers 9 are arranged and positioned such that at each spacer 9 the string 1 is held towards the centre of the casing 3 and such that the string 1 will not contact with the casing 3 at any position between adjacent spacers 9. Beyond the last spacer 9 at each end of the plurality of spacers 9, the string 1 makes glancing contact 10 with the casing 3 as shown in Figure 2. The distance between each last spacer 9 and the respective glancing contact 10 will be random but its lower limit will be determined by characteristics of the well and spacers 9. Thus the spacers 9 ensure that there is no contact between the string 1 and casing 3 for at least a selected minimum distance.

In general terms the transmission and receiving characteristics of the system improve as the spacing between the glancing contacts 10 is increased. However, there is a trade off against the cost involved in lengthening the minimum distance. In general the actual spacing between the glancing contacts 10 will be greater than the minimum distance but this simply serves to improve the system.

The portions of the string 1 and casing 3 between



the glancing contacts 10 are hereinafter referred to as the isolated portion of the string 1a and the corresponding portion of the casing 3a.

Figure 3 shows an equivalent (lumped parameter) circuit for a typical length of the production string 1 and casing 3. The string 1 and casing 3 are respectively represented by series of resistors  $R_s$  and  $R_c$ . The leakage paths between the string 1 and casing 3 are represented by a series of resistors  $R_{g+b}$  and the leakage paths between the casing 3 and remote earth E are represented by resistors  $R_e$  and capacitors  $C_e$ . If a signal is applied to the string 1 or casing 3 the strength of the signal will decrease with distance away from the source due to the losses through the leakage paths to remote earth E. Further, as mentioned above the potential of the string 1 and casing 3 will tend to equalise.

Figure 4 shows a simplified equivalent circuit for the portions of the production string 1a and casing 3a in the region of the relay station 6 during reception of a signal. Except those 10 at either end of the portions 1a, 3a, the leakage paths due to glancing contacts have been removed. Thus the resistors  $R_{g+b}$  are replaced by resistors  $R_b$  of much higher value representing the leakage through brine alone. The resistance through the brine in the region of the relay station 6 is so large compared with that provided by the glancing contacts 10 at the ends of the isolated portion of string 1a that the effect of the brine can essentially be ignored.

During reception of a signal, because there is no current path through the string portion 1a due to the isolation joint 7 and because the string portion 1a is effectively isolated from the corresponding casing

portion 3a, all of the signal losses for that section of the metallic structure will be from the casing 3a. In this circumstance there will be little potential drop along the two halves of the isolated string portion 1a which essentially provide a direct contact with the glancing contacts 10 at the end of the portions 1a,3a. This means that the potential difference between two longitudinally spaced locations on the casing can be detected and hence a signal extracted from the metallic structure. The fact that all of the signal is forced along the casing 3 in the region of the relay station 6 can serve to increase the potential difference between the two spaced locations on the casing 3.

Figure 5 shows a simplified equivalent circuit for the portions of the production string 1a and casing 3a in the region of the relay station 6 during transmission. As above the leakage paths due to glancing contacts have been removed except those 10 at either end of the portions 1a, 3a. Thus the resistors  $R_{g+b}$  are replaced by resistors  $R_b$  of much higher value representing the leakage through brine alone. The resistance through the brine in the region relay station 6 is so large compared with that provided by the glancing contacts 10 at the ends of the isolated portion of string 1a that the effect of the brine can be ignored. Thus during transmission a current loop path can be considered to exist consisting of the isolated portion of the string 1a, the corresponding portion of the casing 3a and the glancing connection points 10. The two ends of this loop are of course also connected to the remainder of the string 1 and casing 3. The signal generating means 8a causes a current I to flow around the loop path. This flow of current I causes a potential difference to be set up

between the glancing contacts 10 at opposite ends of the isolated portion of string 1a. This potential difference will be  $I \times \text{sumRc}$ , where  $\text{sumRc}$  equals the total resistance of the casing between the glancing contacts 10.

Assuming that the isolation joint 7 is provided at the centre of the isolated portion of the string 1a and the system settles in balance relative to earth, the magnitude of the potential difference between metallic structure and earth at each end of the isolated portion 1a will be  $(I \times \text{sumRc})/2$ . Because a potential difference exists between the positions of the glancing contacts 10 and earth, a signal will tend to travel along the string 1 and casing 3 in each direction away from the relay station 6.

Desired data, for example that received from a data logging station, can be transmitted along the string 1 and casing 3 away from the relay station by encoding a suitable signal onto the string 1 by means of the mechanism described above. The resulting signal propagates away from the current loop path along the string and casing as a single conductor. The signal circuit is completed by an earth return and no wirelines are required. Thus all of the problems associated with the provision of wirelines, especially downhole, can be avoided.

Appropriate receiving means at the mudline or at another relay station (not shown) are used to detect the signal applied to the string 1 and casing 3 and extract the desired data. The receiving means may make use of an inductive coupling or be arranged to measure signals with respect to a separate earth reference.

Thus the range of the signal transmission system can

be dramatically increased by providing a suitable number of relay stations within the casing 3. The relay stations are bi-directional so that the transmission range when transmitting signals down into the well as well as out  
5 of the well is increased.

With the isolation joint located centrally within the isolated portion 1a, the signals in each direction away from the relay station 6 will have substantially equal strength. However, if the isolation joint 7 is  
10 disposed towards one end of the isolated portion 1a, the potential difference generated at the other end of the isolated portion 1a will tend to be greater than  $(I \times \text{sumRc})/2$ . Thus if it is desired to increase the strength of the signal in one direction the isolation joint 7 may  
15 be disposed accordingly.

In an alternative the isolated portion of the production string 1a is provided with an insulating coating to further reduce conduction between the isolated portion 1a and the corresponding portion of the casing  
20 3a.

Figure 6 shows a coil 201 provided on a toroidal core 202 disposed around the production string portion 1a for use in an alternative method of applying a signal to and/or tapping a signal from the production string 1.  
25 In this case inductive coupling is relied on and no isolation joint is used. During transmission the coil 201 is used to induce a current in the string 1 and the current loop path described above acts as a single turn transformer winding. During reception, a signal on the  
30 production string 1 induces a corresponding current in the coil 201 which can be detected. This method of reception does not rely on there being an isolated portion 1a of production string. This coupling method

gives an advantage that it is possible to optimise impedance matching by appropriately choosing the turns ratio.

Figure 7 shows a further embodiment of the invention suitable for use in a well of the type described above which comprises two pigs 301 connected by an electrically conductive strop 302 and disposed within the production string 1 which may or may not be cased. A first of the pigs 301 comprises a local station 303 having an isolation member 7 provided in series with the strop 302 and signal generating means 8a and signal measuring means 8b connected across the isolation member 7. Each of the pigs 301 has a contact 304 for contacting with an internal surface of the string 1.

Signals may be transmitted and received in this embodiment in substantially the same way as described above in relation to the first embodiment. During transmission the strop 302, a portion of the string 1a and the contacts 304 form a current loop path. When current is caused to flow around the loop by the signal generating means 8a a potential difference between the string 1 and earth can be generated at each contact 304 allowing a signal to be transmitted. During reception of a signal, the strop 302 and contacts 304 allow the potential difference between two longitudinally spaced points on the string 1 to be measured so that a signal can be extracted from the string 1.

In this embodiment signals may be sent to and from the first pig 301. In particular, signals may be sent from the pig 301 which allow the location of the pig 301 to be determined and/or which represent a quantity, such as wall thickness, measured by the pig 301.

In implementing this embodiment it is desirable to

minimise the impedance of the conductive strop 302 and the contacts 304 between the pigs 301 and the production string 1. Wire brushes (not shown) provided around the pigs 301 for cleaning purposes may be used as the contacts 304.

One possible mechanism for determining the location of the pig 301 would be to arrange trigger means at spaced locations along a pipeline which cause the pig 301 to send an appropriate signal. Another method would be to determine the time difference of arrival of the signal at each end of the pipeline.

It will be appreciated that this system may be used whether the pigs 301 are within a cased or uncased section of string. Further the system may be used in other pipeline systems besides wells.

In alternatives more than two pigs may be used. Three pigs connected by two conductive members may be used and the local unit disposed at the central pig. This can facilitate equalisation of the transmission characteristics in both directions away from the local unit.

Figure 8 schematically shows a third embodiment of the present invention which is a system for transmitting data from inside a section of a cased well to a substantially adjacent position outside of the casing.

Referring to Figure 8 a metallic production string 401 is surrounded by a metallic casing 403 which form part of a cased well. An isolation joint 407 is provided in the string 401 and an internal unit 408 including transmitting means (not shown) is connected across the isolation joint 407. At equally spaced distances from the isolation joint 407, generally annular electrically conductive packers 411 are provided between the string

401 and casing 403. The electrically conductive packers 411 are spaced by a selected distance  $L$  and provide a good electrical connection between the production string 401 and the casing 403.

5       The portion 401a of the production string 401 between the spaced pair of packers 411 is provided with an insulating coating 409. The coating 409 helps to ensure that there is no conduction path or at least only a very poor conduction path between the string 401 and  
10 casing 403 at all points between the packers 411.

      An external unit 413 comprising receiving means (not shown) and a toroid 415 is provided outside of the casing 403 at a position which is between the pair of spaced packers 411. The toroid 415 surrounds the casing 403 and  
15 is arranged to act as an inductive coupling means such that any net magnetic flux flowing through the toroid generates a signal which can be detected by the receiving means (not shown).

      The system is arranged to be used to transmit  
20 signals from the internal unit 408 to the external unit 413 by the mechanism described below.

      The insulated portion of the production string 401a, a corresponding portion of the casing 403a, and the pair of conductive packers 411 form a current loop path around  
25 which current may flow. However, the loop is imperfect such that there are other current flow paths and losses will occur. There can be considered to be a leakage loop via earth which accounts for the losses.

      The current flow, at an arbitrary instant, around  
30 the current loop path as well as along the leakage paths is shown by arrows in Figure 8.  $I_s$  represents the current flowing through the insulated portion 401a of production string 401,  $I_c$  represents the current flowing in the

corresponding portion of the casing 403a and  $I_e$  represents the leakage current to earth.

At the particular instant represented by the arrows in Figure 8, current  $I_s$  flows up the production string 401 away from the isolation joint 407, a portion of the current passes through the conductive packer 411 to the casing 403 but a further portion of the current continues up the string with subsequent losses to earth. At the casing 403 the path splits again and a proportion of the current  $I_c$  continues around the current loop path while the remainder travels along the casing 403 away from the current loop path and contributes to the leakage to earth. At the lower end of the insulated portion of the string 401a, current from the casing  $I_c$  returns to the string 401 via the respective conductive packer 411 and leakage currents from earth  $I_e$  join this flow back towards the isolation joint 407.

Figure 9 shows a simplified equivalent circuit for the current loop path and the leakages to earth. The resistances of the portion of the production string 401a, the corresponding portion of the casing 403a and earth are represented by resistors  $R_s, R_c, R_e$  respectively.

From the equivalent circuit and the above description, it can be seen that  $I_s = I_c + I_e$ . It follows that the current  $I_s$  flowing through the insulated portion of the production string 401a does not equal the current  $I_c$  flowing through the corresponding portion of the casing 403a. This in turn means that there is a net magnetic flux generated by the current flowing around the loop path. The loop path is encircled by the toroid 415 and hence the toroid 415 is linked by the net flux. Therefore, as current flows around the loop, the existence of, and variations in, that current may be



detected by monitoring signals generated in the toroid 415.

It therefore becomes possible to communicate between the internal and external units 408,413 by  
5 injecting appropriate signals onto the production string 401 and monitoring the signals generated in the toroid 415.

For this technique to work it is important that not all of the current  $I_s$  which is injected into the  
10 production string 401 continues around the current loop. That is to say, significant and appropriate leakages to earth and/or away from the current loop must be provided for. In practice such leakages will tend to occur because of the existence of the remainder of the metallic  
15 structure of the well and because the casing 403 will be in contact with earth or another conductive medium, such as sea water.

The level of signal obtained in the toroid 415 can be adjusted by making appropriate design choices. For  
20 example, the position of the toroid along the insulated portion of the string 401a and the position of the isolation joint 407 may be selected. Further, the spacing  $L$  between the conductive packers 411 may be changed, as may the length of the insulated portion of  
25 the production string 401a. The aim is to maximise the receivable signal by increasing the resistance of the casing loop  $R_c$  relative to the leakage resistance  $R_e$  as far as is practicable. In the first instance this may be achieved by increasing the spacing between the  
30 conductive packers. Theoretically there will come a point where spacing between the packers is electrically optimised, since increased spacing, at some stage, will begin to significantly increase the resistance of the

leakage path  $R_e$ . Generally however, other practical considerations will prevent this electrical optimised spacing being reached. The exact nature and conductive properties of the packers 411 may also be selected to vary performance.

Although the position of the toroid along the current loop path/insulated portion 401a is not crucial, the best results are likely to be achieved towards a central position to balance signals generated during positive and negative going cycles and avoid any undesirable edge effects.

It will be noted that this system does not require insulation between the production string 401 and the casing 403 along the whole of the well's length, it is merely preferable along the length chosen to give the necessary transmitting characteristics.

Although this technique has been described with reference to a cased portion of a well, it will be appreciated that the technique is equally appropriate for other situations where it is desired to signal from within a conductive member which surrounds the transmitter. For example, the system can be used to signal from within the casing of flow lines other than production strings and from within flow lines themselves providing that a suitable inner conductor is provided.

In a particular case this system can be used with apparatus along the lines of that shown in and described with reference to Figure 7. That is to say the current loop path may be formed by a portion of a flow line 1, two pigs 301 and an interconnecting conductive strop 302. If a toroid is then provided around the flow line 1 it will be possible to pick-up signals generated by the transmitting means 8a located in the pig 301 as it passes

through the region of the toroid.

It can be noted that this embodiment makes use of the same phenomenon as described above with reference to the first and second embodiments. However, in the present embodiment it is the effects which occur in the current loop path itself which are used rather than the current which leaks away from the current loop path along the production string and casing 1,3.

It should also be noted that the implementation of the present embodiment will, at least in some circumstances, be compatible with the previously described embodiments. Thus systems may be provided in which signalling along the metallic structure to a remote location and signalling from within the casing to adjacent equipment outside of the casing is possible.

Although not shown in the drawings, the casing 3 of a well is typically made up of screwed together sections. In alternative implementations of the invention, some or all of the joints between the casing sections may be treated so as to cause a level of discontinuity in conductivity of the casing. This can typically be achieved by coating the mating surfaces at each joint with an isolating medium which does not prejudice the sealing requirements for the casing.

Introducing such discontinuities can significantly change the electrical characteristics of the well as a whole. At least in some circumstances this may lead to improved performance of the relevant embodiments described above. For example the range of transmission systems shown in Figures 1 and 2 may be improved. Improvements can be achieved whether the discontinuities are provided in the region of the current loop path, i.e. between the spaced connections or away from that region.

The tendency is to force more of the signal into the string rather than the casing and to increase the proportion of the signal which travels away from the region of the loop.

5           In the case of the system shown in Figure 8, the inclusion of an isolation medium between sections of the casing in the region between the spaced connections particularly aids performance as it reduces the screening effect of the casing. Looked at another way, it tends  
10 to increase the impedance of the string-casing loop and thus increase the difference between the current flowing in the string  $I_s$  and in the casing  $I_c$ .

          It should be noted that, although as mentioned above, the present embodiments, and present invention in  
15 general, may function better if discontinuities exist between mating sections of casing this is not a requirement for operation. Thus the system may be such that the casing is substantially electrically continuous along its whole length or at least in the region of the  
20 loop. This is true for the casing of a well and the casing of any other pipeline as well for as any corresponding surrounding outer member such as the string in the embodiment shown in figure 7.

## CLAIMS

1. A data transmission system in which metallic structure of a pipeline system is used as a signal channel and earth is used as return comprising means for forming a signal coupling loop having first and second conducting portions electrically connected to one another at spaced locations, the metallic structure comprising at least one of the conducting portions, and a local unit having transmitting means for applying a signal to one of the conducting portions whereby in use a potential difference is generated between earth and the metallic structure in the region of the loop which causes a signal to be propagated along the metallic structure away from the loop, wherein the means for forming the loop is arranged to ensure that the spaced locations are separated by at least a minimum distance selected to give desired transmission characteristics.
2. A data transmission system according to Claim 1 in which the pipeline system comprises an inner flow line and a surrounding casing wherein, one conducting portion comprises a portion of the flow line and the other conducting portion comprises a surrounding portion of the casing.
3. A data transmission system according to Claim 2 in which the means for forming the loop comprises insulating spacer means for keeping the flow line spaced from the surrounding casing for the selected minimum distance.
4. A data transmission system according to Claim 2

or Claim 3 in which the spaced connections between the first and second conducting portions comprise glancing contacts between the flow line and casing beyond the selected region.

5

5. A data transmission system according to any preceding claim in which the local unit comprises receiving means for receiving incoming signals transmitted along the metallic structure.

10

6. A data transmission system according to Claim 5 in which the local unit is arranged to act as a relay station.

15

7. A data transmission system according to any preceding claim in which the transmitting means is arranged to apply signals substantially at the midpoint of the respective conducting portion.

20

8. A data transmission system according to any preceding claim in which the transmitting means comprises an isolation member disposed in series with the respective conducting portion and a signal generating means connected across the isolation member.

25

9. A data transmission system according to any of Claims 1 to 7 in which the transmitting means comprises inductive coupling means disposed around the respective conducting portion.

30

10. A data transmission system according to Claim 1 in which one conducting portion comprises a portion of

a pipeline or flowline and the other conducting portion comprises at least one electrically conductive elongate member connecting at least two pigs disposed within the pipeline or flowline and wherein the spaced  
5 connections to complete the current loop path are provided at the pigs.

11. A data transmission system in which metallic structure of a well including a production string and  
10 casing is used as a signal channel and earth is used as return comprising a local unit having receiving and/or transmitting means coupled to the string for receiving signals from and/or transmitting signals along the signal channel and insulating spacer means  
15 arranged to ensure that the production string and casing are spaced from one another for at least a selected minimum distance in the region of the local unit, said minimum distance being selected to give desired reception and/or transmission characteristics.

20  
12. A data transmission system according to any one of Claims 2 to 4 and 11 in which the casing comprises a plurality of separate sections, and mating surfaces at one or more joint between adjacent sections are  
25 coated with an isolating medium.

13. A method of data transmission in which metallic structure of a pipeline system is used as a signal channel and earth is used as return comprising the  
30 steps of:  
arranging a signal coupling loop having first and second conducting portions electrically connected to one another at spaced locations, the metallic

structure comprising at least one of the conducting portions;

applying a signal to one of the conducting portions to generate a potential difference between earth and the metallic structure in the region of the loop and  
5 cause a signal to be propagated along the metallic structure away from the loop; and

ensuring that the spaced locations are separated by at least a minimum distance selected to give desired  
10 transmission characteristics.

14. Signal receiving apparatus for use with a data transmission system in which metallic structure of a pipeline system is used as a signal channel and earth  
15 is used as return, comprising a local unit having receiving means, means for providing electrical contact between the local unit and at least two spaced locations on a portion of the metallic structure and means for ensuring that the two spaced locations are  
20 separated by at least a minimum distance selected to give desired reception characteristics.

15. A method for receiving a signal from the metallic structure of a pipeline system which is used as a  
25 signal channel in a data transmission system with earth as return, comprising the steps of providing a local unit having receiving means; providing electrical contact between the local unit and at least two spaced locations on a portion of the metallic  
30 structure; and ensuring that the spaced locations are separated by at least a minimum distance selected such to give desired reception characteristics.



16. A data transmission system for use in pipeline systems which transmission system comprises:  
means for forming a signal coupling loop comprising a portion of an inner conductive member and a  
5 corresponding portion of an outer conductive member electrically connected to one another at two spaced locations, the outer conducting member surrounding the inner conductive member and being part of the metallic structure of a pipeline system;  
10 an internal unit disposed within the outer member and having transmission means for injecting a signal into the loop; and  
an external unit disposed outside the outer member and comprising inductive coupling means arranged to be  
15 linked by flux generated by current in the loop, the arrangement being such that in use the current flowing in said portion of the inner member does not match the current flowing in the corresponding portion of the outer member whereby signals are generated in  
20 the inductive coupling means so allowing communication from the internal unit to the external unit.
17. A data transmission system according to Claim 16 in which the spaced locations are separated by at  
25 least selected minimum distance chosen to give desired transmission characteristics.
18. A data transmission system according to Claim 16 or Claim 17 which is arranged for use in a pipeline  
30 system comprising an inner conductive flowline and an outer conductive casing, said outer member comprising the casing and said inner member comprising the flowline.

19. A data transmission system according to Claim 18 in which the casing comprises a plurality of separate sections and mating surfaces at one or more joint between adjacent sections are coated with an isolating medium.

20. A data transmission system according to Claim 18 or Claim 19 in which the electrical connections between the flowline and casing comprise glancing contacts and/or conductive packers.

21. A data transmission system according to any one of Claims 16 to 20 in which the means for forming the loop comprises insulating spacer means.

22. A method of data transmission for use in pipeline systems which method comprises the steps of:  
forming a signal coupling loop comprising a portion of an inner conductive member and a corresponding portion of an outer conductive member electrically connected to one another at two spaced locations, the outer conducting member surrounding the inner conductive member and being part of the metallic structure of a pipeline system;  
injecting a signal into the loop from an internal unit disposed within the outer member; and  
disposing an external unit outside the outer member which unit comprises inductive coupling means arranged to be linked by flux generated by current flowing in the loop,  
and the arrangement being such that the current flowing in said portion of the inner member does not match the current flowing in the corresponding portion

of the outer member whereby signals are generated in the inductive coupling means so allowing communication from the internal unit to the external unit.

- 5 23. A method of data transmission according to Claim 22 in which the spaced locations are separated by at least selected minimum distance chosen to give desired transmission characteristics.
- 10 24. Apparatus for use with a metallic structure to provide a system according to any one of Claims 1 to 12 and 16 to 21 or carry out a method according to any one of Claims 13, 15 and 22.

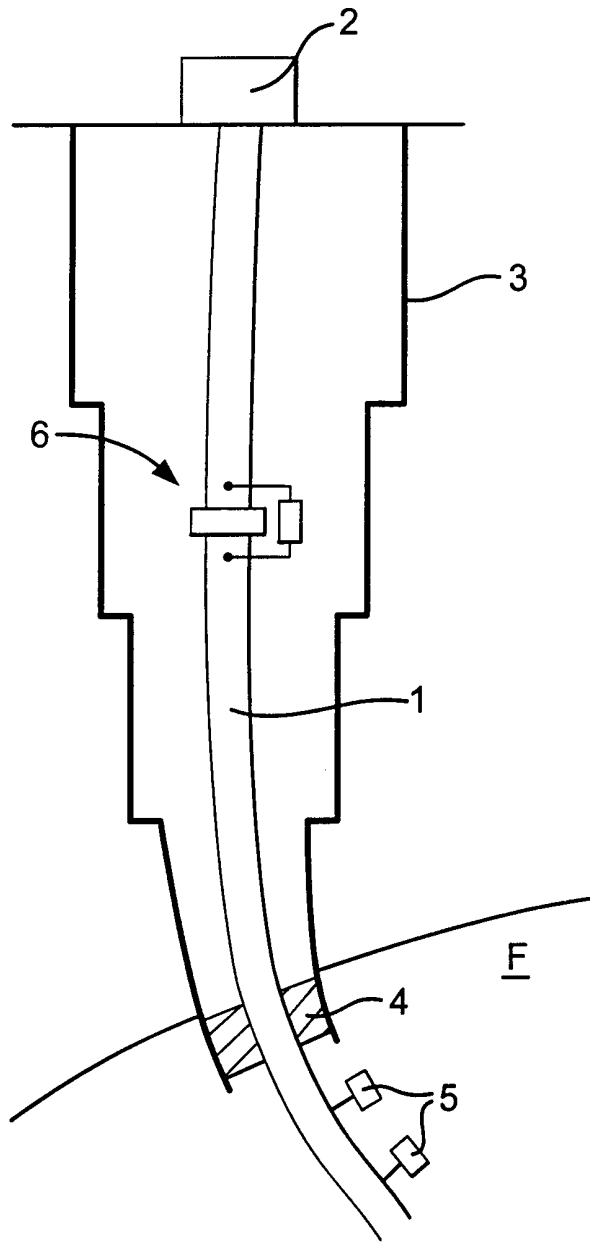

**Fig. 1**

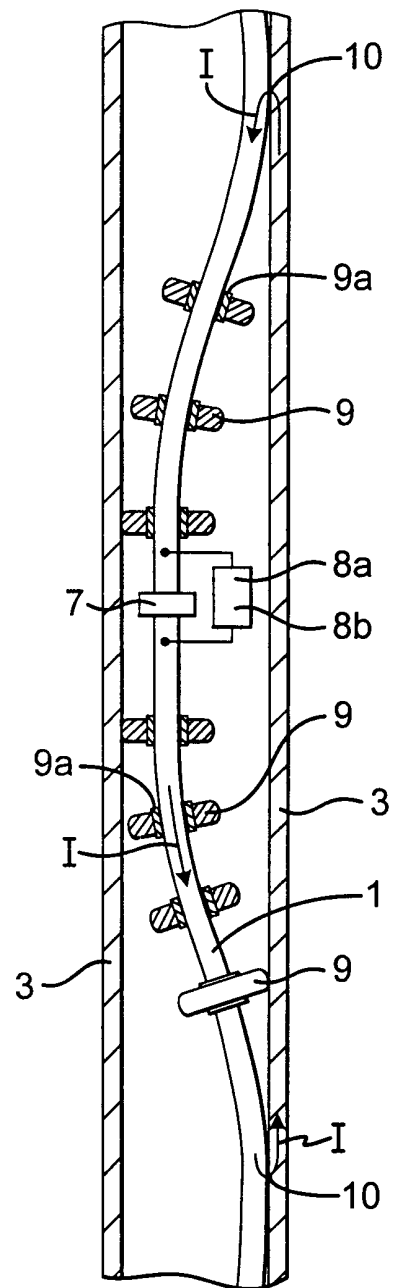

**Fig. 2**

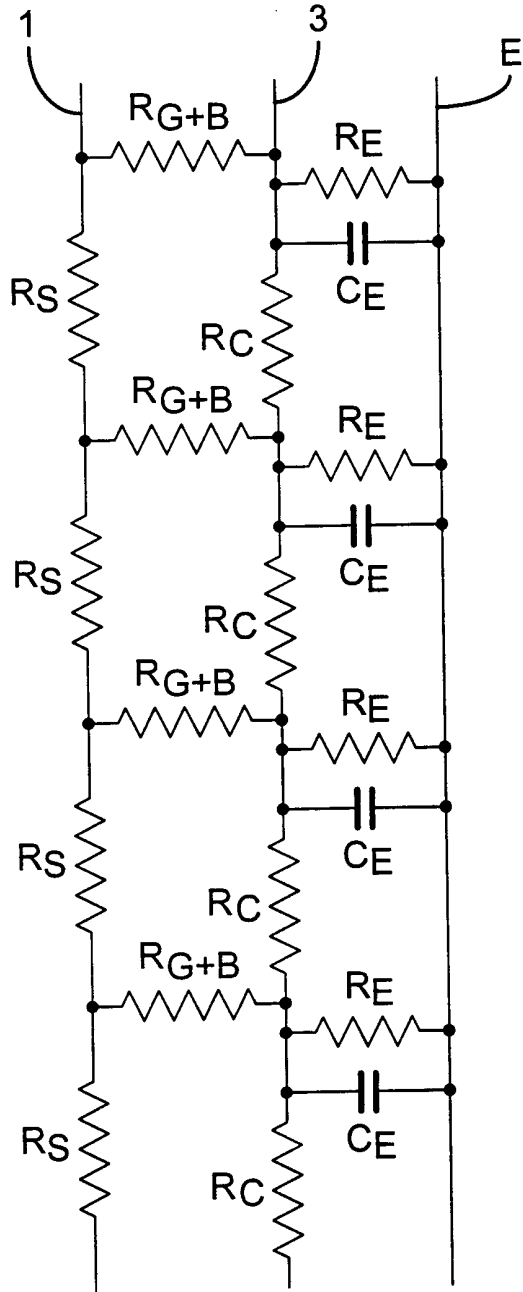

**Fig. 3**

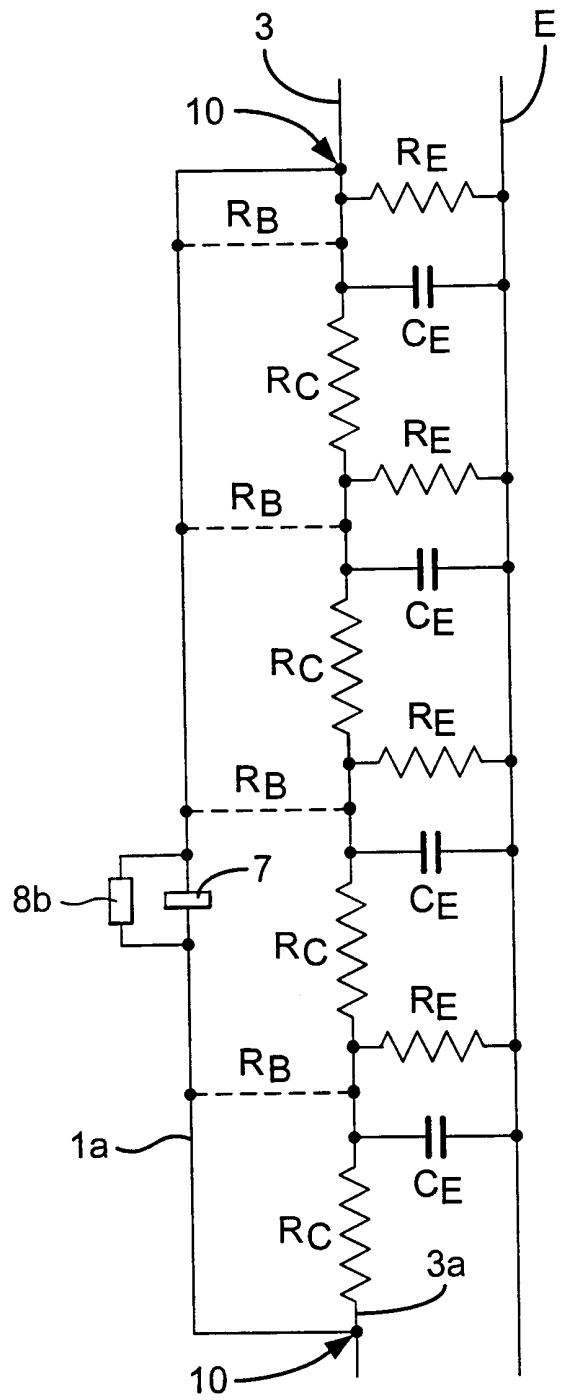

**Fig. 4**

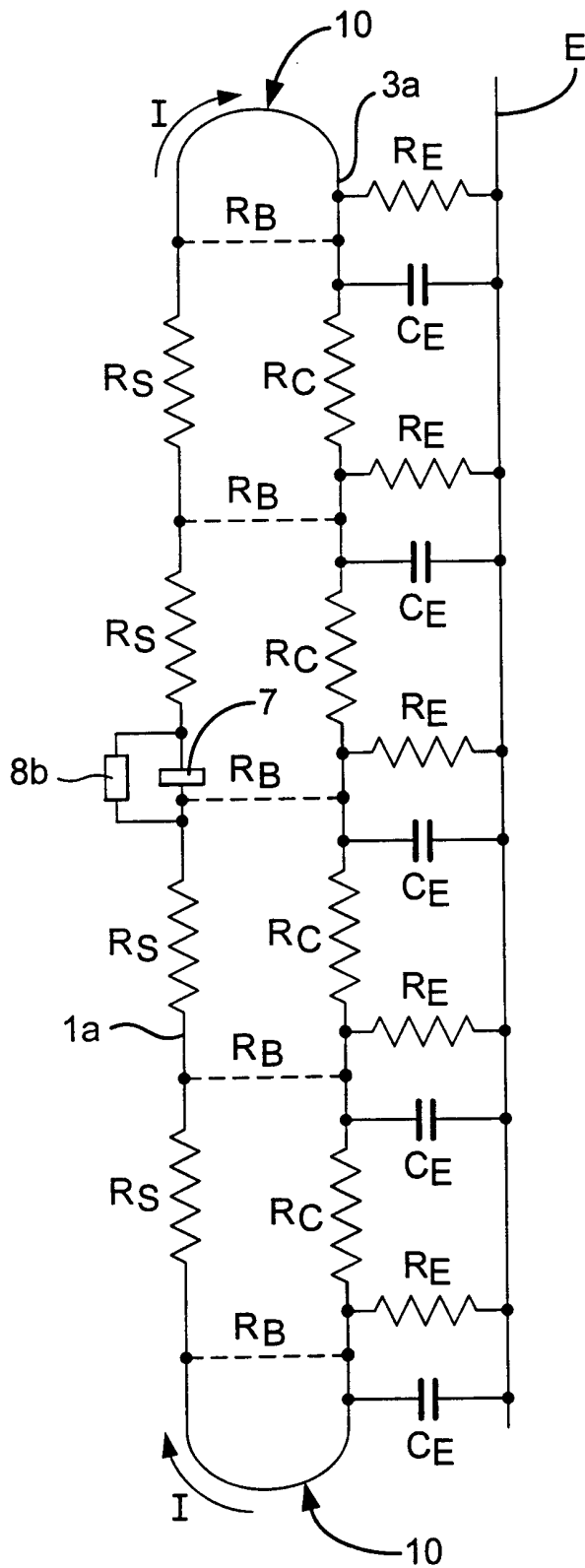

**Fig.5**

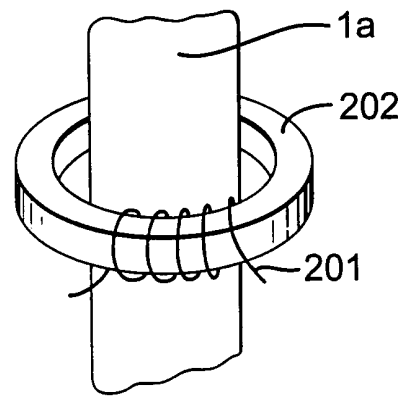

**Fig.6**

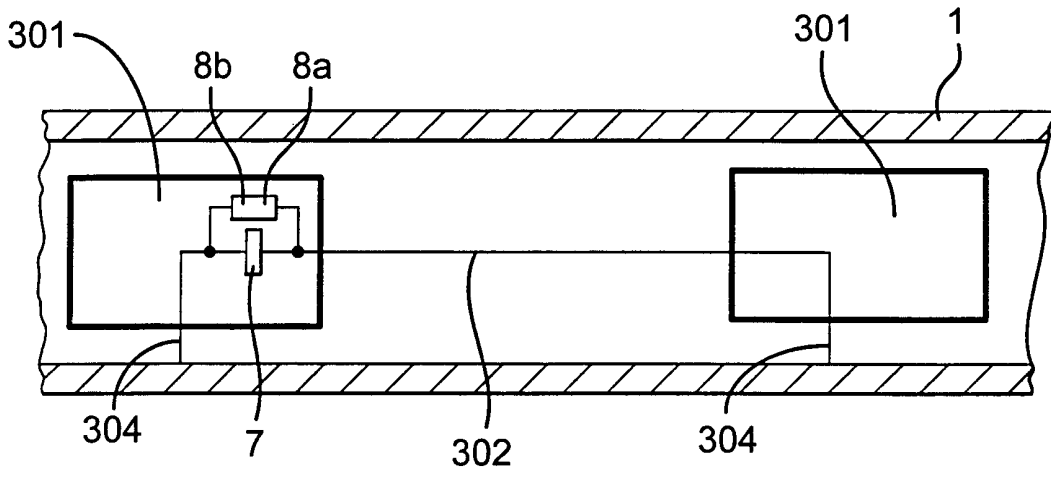

*Fig. 7*

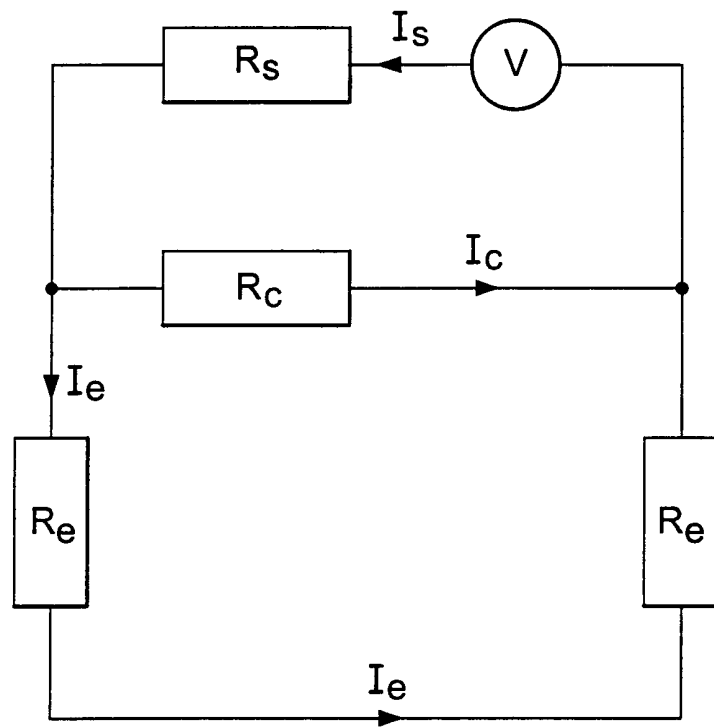

*Fig. 9*

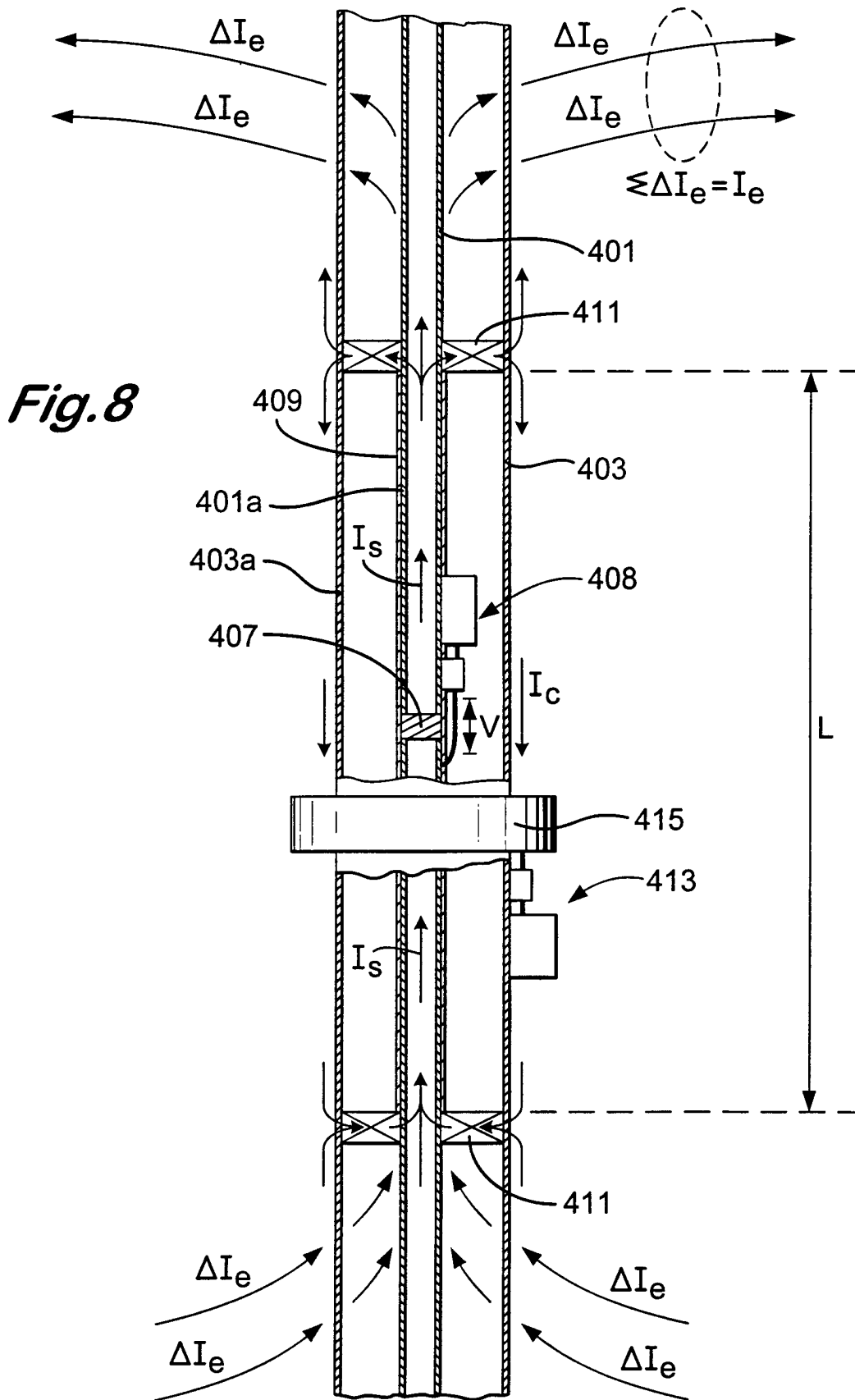

**Fig. 8**



# INTERNATIONAL SEARCH REPORT

International Application No

PCT/GB 00/02538

**A. CLASSIFICATION OF SUBJECT MATTER**  
IPC 7 E21B47/12 F17D5/06

According to International Patent Classification (IPC) or to both national classification and IPC

**B. FIELDS SEARCHED**

Minimum documentation searched (classification system followed by classification symbols)

IPC 7 E21B F17D H04B

Documentation searched other than minimum documentation to the extent that such documents are included in the fields searched

Electronic data base consulted during the international search (name of data base and, where practical, search terms used)

EPO-Internal, PAJ

**C. DOCUMENTS CONSIDERED TO BE RELEVANT**

Category °	Citation of document, with indication, where appropriate, of the relevant passages	Relevant to claim No.
P, X	WO 99 37044 A (FLIGHT REFUELING LTD ;HUDSON STEVEN MARTIN (GB)) 22 July 1999 (1999-07-22) abstract; figure 4 ---	1, 11, 13-16, 22
A	US 2 364 957 A (DOUGLAS NORVEL) 12 December 1944 (1944-12-12) page 2, right-hand column, line 14 - line 29; figure 1 ---	1, 11, 13-16, 22
A	US 3 129 394 A (LONG FRANCIS V.) 14 April 1964 (1964-04-14) column 2, line 52 - line 55; figure 1 column 3, line 61 - column 4, line 49; figure 2 ---	1, 11, 13-16, 22
	-/--	

Further documents are listed in the continuation of box C.

Patent family members are listed in annex.

° Special categories of cited documents :

"A" document defining the general state of the art which is not considered to be of particular relevance

"E" earlier document but published on or after the international filing date

"L" document which may throw doubts on priority claim(s) or which is cited to establish the publication date of another citation or other special reason (as specified)

"O" document referring to an oral disclosure, use, exhibition or other means

"P" document published prior to the international filing date but later than the priority date claimed

"T" later document published after the international filing date or priority date and not in conflict with the application but cited to understand the principle or theory underlying the invention

"X" document of particular relevance; the claimed invention cannot be considered novel or cannot be considered to involve an inventive step when the document is taken alone

"Y" document of particular relevance; the claimed invention cannot be considered to involve an inventive step when the document is combined with one or more other such documents, such combination being obvious to a person skilled in the art.

"&" document member of the same patent family

Date of the actual completion of the international search

5 October 2000

Date of mailing of the international search report

13/10/2000

Name and mailing address of the ISA

European Patent Office, P.B. 5818 Patentlaan 2  
NL - 2280 HV Rijswijk  
Tel. (+31-70) 340-2040, Tx. 31 651 epo nl,  
Fax: (+31-70) 340-3016

Authorized officer

Christensen, J

# INTERNATIONAL SEARCH REPORT

Intern <span style="font-size: 0.8em;">)</span> al Application No PCT/GB 00/02538
--

**C.(Continuation) DOCUMENTS CONSIDERED TO BE RELEVANT**

Category °	Citation of document, with indication, where appropriate, of the relevant passages	Relevant to claim No.
A	WO 93 26115 A (FLIGHT REFUELING LTD ;DICKIE NEIL MARSHALL (GB); HUDSON STEVEN MAR) 23 December 1993 (1993-12-23) cited in the application & EP 0 646 304 A 5 April 1995 (1995-04-05) ---	
A	PATENT ABSTRACTS OF JAPAN vol. 005, no. 145 (E-074), 12 September 1981 (1981-09-12) & JP 56 078240 A (TSURUMI SEIKI:KK), 27 June 1981 (1981-06-27) abstract -----	

# INTERNATIONAL SEARCH REPORT

Information on patent family members

International Application No

PCT/GB 00/02538

Patent document cited in search report	A	Publication date	Patent family member(s)	Publication date
WO 9937044	A	22-07-1999	AU 2067499 A	02-08-1999
US 2364957	A	12-12-1944	NONE	
US 3129394	A	14-04-1964	NONE	
WO 9326115	A	23-12-1993	AT 180129 T	15-05-1999
			AU 4347493 A	04-01-1994
			DE 69324919 D	17-06-1999
			DE 69324919 T	13-01-2000
			EP 0646304 A	05-04-1995
			ES 2131112 T	16-07-1999
			NO 944837 A	14-02-1995
			US 5587707 A	24-12-1996
JP 56078240	A	27-06-1981	NONE	