

가

가

2

2

2

2

.2

가

가

가

가

가

가

가

가

가

HF-

/

가

가

가

가

2

2

가

2

가

가

가

가

가

1
2
3
4
5
6
7
8

가

2

가

2

가

2

1 (30) (10) (10) 4 (30) (10)

(10) 2 (11), (12) (1)

1), (12) (37) (37) (37.1)가 (30) (37) 6 (30)

10) (14) (10) (20) (14) (14)

2 (11), (12) (20)가 (30) (14)가 (20)

(14) (14.1)가 (19) (14) (19) (14) (16)

가 (20.1) (11), (12) (14) (20) (11), (12)

(14) (24) (30) (35.1) (35.1)

(30) 2 (33), (34) (33), (34) (33), (34)

(30) (31), (32) (33), (34) (14) (17), (18) (33), (34)

(11), (12) (38)가 (30) (38) (14) (31), (32)

(14.1) (24) (38) (14.1) (30) (38)

(14) (14.1) (19) (24) (39)가 (14) (17),

(18) (30) (30) (31), (34) (11), (12) (14) (20)

(30) (30) (14) (30)가 (20)

(10) 2 (30) (30)

, 2 (30)

3 가 2 (30) (40)
 (41) 2 (42), (43) U (40) (42), (43) (41) (41)
 (34) (45) (40)가 (30) (45)
 4b)가 (40) (44a), (44b) (41) (42), (43) (44a), (4
 (37) (40)가 (30) 2 (30)
 2 가 (40)가 (10) (30) (36)
 (20) (30) (36) (2
 0) (10) (24) (30) (34) (14) (18) (32)
 (18) 가 (32) (11) (34) (14) (17)
 9) (14) 2 (17) (18) (flank)(19)가 (1)
 (30) (35.1) (19) (33), (34) (35.1) (17),
 (18) (10) (30) (10) (40) 2 (10)
 가 (30) (10) (10) (14) (10) (10)
 가 (30) (30) (30) (30) 가 (33), (
 34) (31), (32) 2 (40) (41) (31) (37), (37.1)가
 1 (20) (33) (24) (21) (21)
 (30) (11), (12) (10) 가 가 (11),
 4 (12) (11), (12) (10) (10) 1 , 4
 0° (26) (63)(7) (72)(8) (11), (12) (25) 가 , 9
 26) (63) (72) (26) 가 (27.1) (27.1) (27)
 (27) (63) (72) 가 (10) (27.1) (27)
 (28) (11), (12) (27.1) (21) (21)
 (30) (25) (30) (22), (23)가 (27.1)
 (14)가 (20) (14) (28) (14)
 (27) (11), (12) /
 (10) (30) (35.2) (35.2)
 2 가 (30.1) (30.1) (30.2) 가
 (30.3) (30.3) (30.4) (30.4) (3)
 0.3) (31, 32) (31), (32) (30.4) (33), (34)
 (33), (34) (33), (34) (35.2) . 2 (33),
 (34) (30) (35.1)가 (20) (31), (32)
 (11), (12) (22), (23) (30) (36)

(10) , (24) (30) (31), (32)
 (33, 34) (21) 가 (21) (
 30) (50) (30) (30) 5 5
 (30) (50) (50) (30)
 (50) (51), (54) (51), (54) 2 (52),
 (53) 2 (51), (54) (51), (54) (52), (53) (
 56), (57)가 (52), (53) (55), (58) (51), (54)
 (56), (57) (55), (58) (55), (58)
 (56, 57) (55, 58) (30) (50)
 (59)가 (51), (54) (59) (
 51, 54) (51), (54) (59)가 (
 50) (39.1)가 (30) (37.1)
 (39.1)(가)가 (30) (33), (34)
 5 (54) (59)
 (59) (50) (30) 가
 가 (39.1) , 가 (51) (50)
 (30) (35.1) , 2 (51), (54) (33), (3
 4) (50) (30) 가 (56), (
 57) 가 (55), (58) (37.1)
 (50) 가 가 (39.1)가
 6 (40) 2 (30) (
 40) 3 (40) (30) (30) 2
 (40) (41) 가
 7 (60)가 (30) (35.2)
 (61) 가 2 (63) (62)가 (62)
 (63) (60) (61) (63)
 (30) (30.4) 7 (60) 2 (63)
)
 8 (70)가 (35.2) 가 (72)
 가 (76)가 가 (76) (70) (72)
 (74)가 (74) (30) (30.2)
 8 (70)가 (71)
 (70)

(57)
 1.
 (10) (11, 12 30) (11, 12)
 (30) 가 (30) (10)
 (30) (50) (35.1) (35.1)
 (31, 32) 가 (33, 34) (50) (56, 57)
 (33, 34) (31, 32) (37, 37.1)

2.
 1

	(30)	(31, 32)	(30.4)
1	3.		
2	(20)	(10)	(20)
3	4.		
	(14)가	(10) (20)	(14)
	(30)	(20)	
1	5.		
4	(30)	(35.2)	
	(35.2)가	가	
	(30) 2	(30.1)	
1	6.		
5		(30) (40)	
6	7.		
	(40)가	(41)	
	(41)	(44a, 44b)	
1	8.		
7	(10)		
1	9.		
8	(30)	(35.1) 가	(50) (59)
가	(39.1)	(51, 54)	(50) (
30)	(39.1)	(50)	(30)
1	10.		
9		/	(10) (12a)

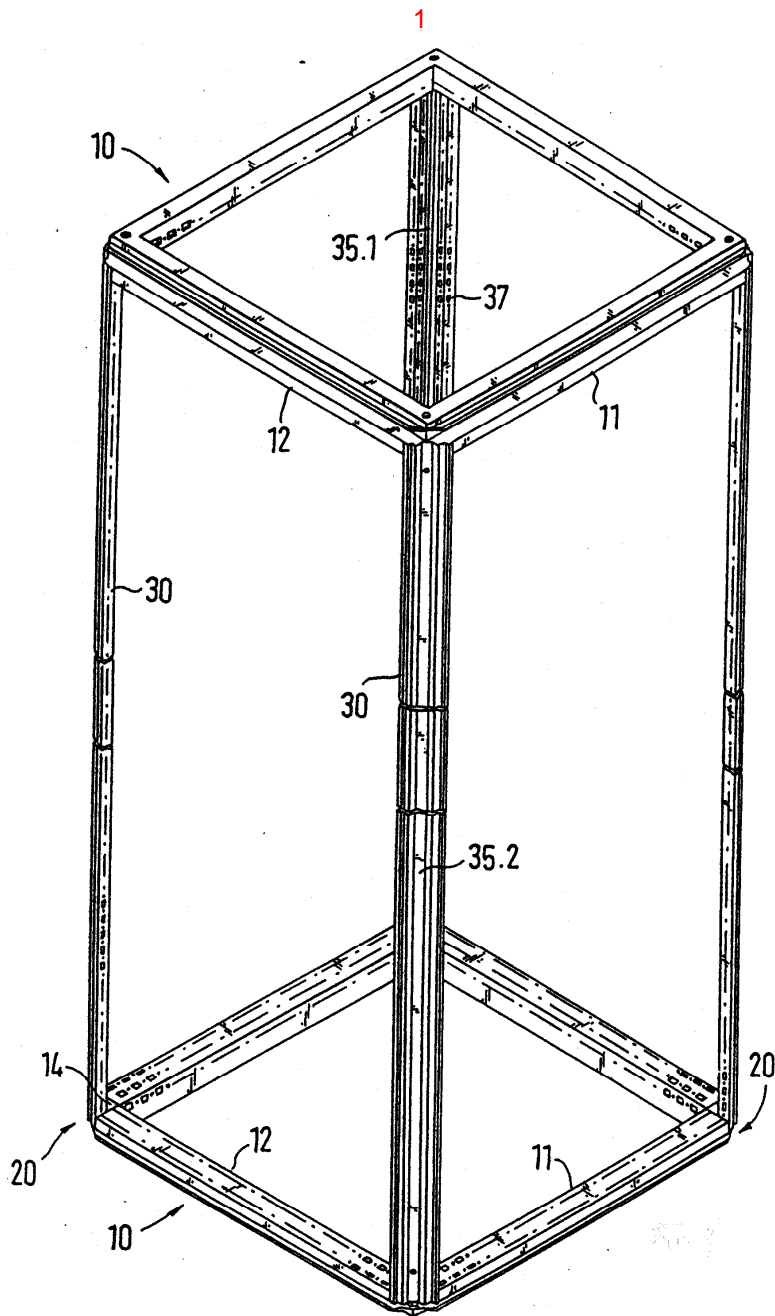

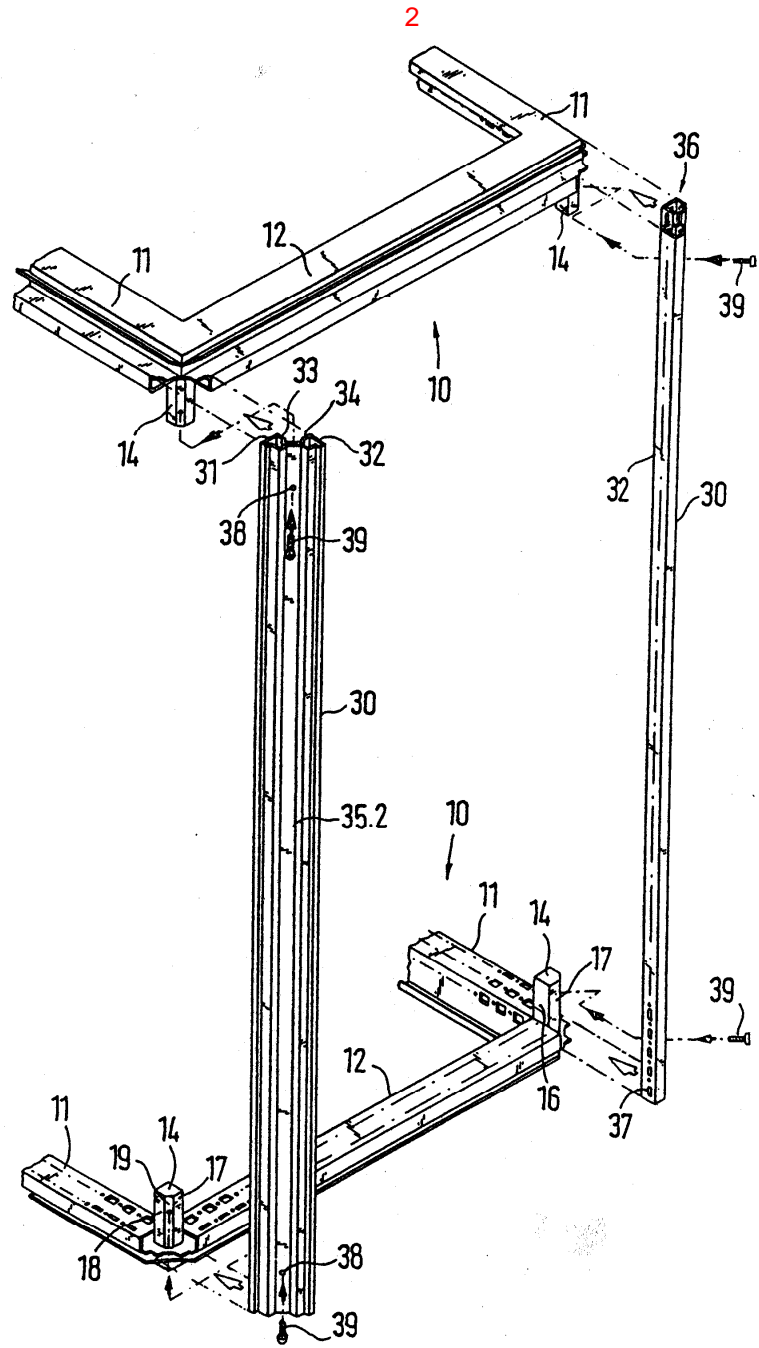

3

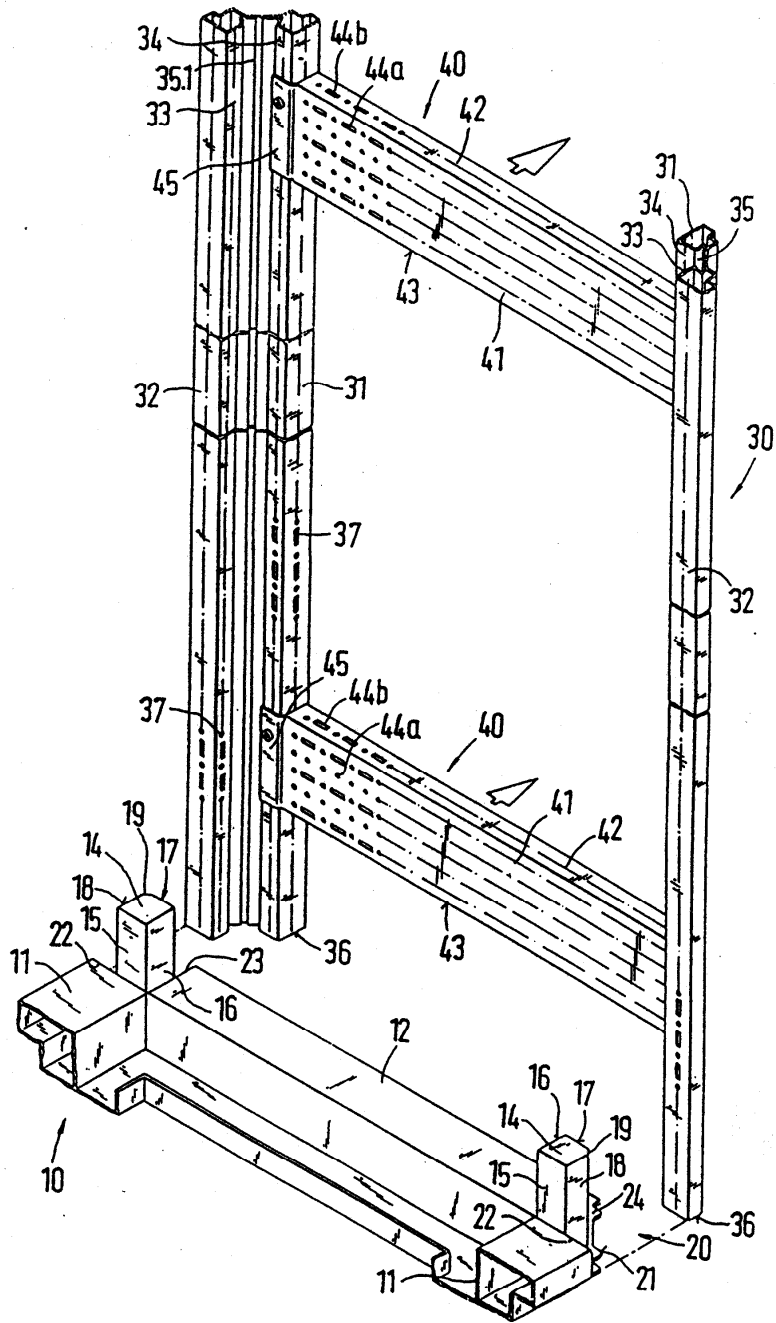

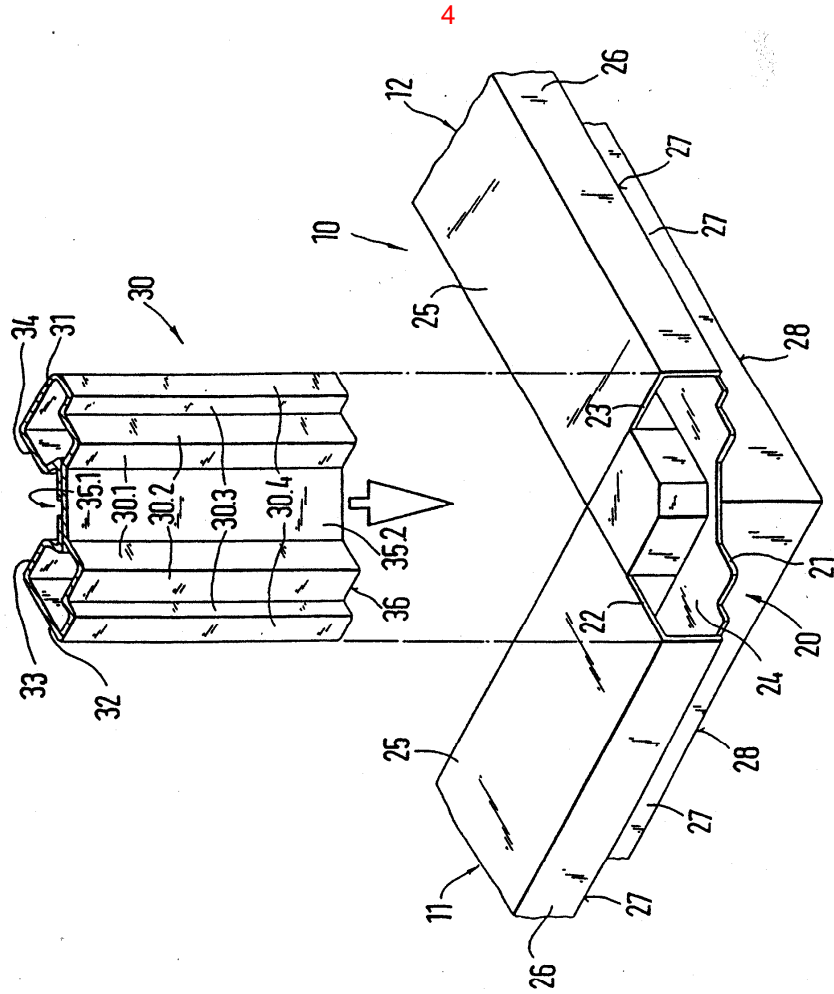

5

