



US 20080067910A1

(19) **United States**

(12) **Patent Application Publication**
Butler

(10) **Pub. No.: US 2008/0067910 A1**

(43) **Pub. Date: Mar. 20, 2008**

(54) **REFRIGERATOR SHELVING SYSTEM WITH ITEM RETAINER**

Publication Classification

(75) Inventor: **James C. Butler**, Sidney, OH (US)

(51) **Int. Cl.**
F25D 25/02 (2006.01)
A47B 96/02 (2006.01)

Correspondence Address:
HARNES, DICKEY & PIERCE, P.L.C.
P.O. BOX 828
BLOOMFIELD HILLS, MI 48303

(52) **U.S. Cl.** **312/408**

(73) Assignee: **THETFORD CORPORATION**,
Ann Arbor, MI (US)

(57) **ABSTRACT**

(21) Appl. No.: **11/855,636**

(22) Filed: **Sep. 14, 2007**

A retention system for a shelf of a refrigerator includes a retainer member and at least one connector member. The retainer member may extend between the first and second lateral sides of the shelf and may include a central portion positionable above the shelf. The at least one connector member may connect the retainer member to the shelf. The at least one connector member may include a locking mechanism for securing the retainer member at various points along a length of at least one of the lateral sides of the shelf.

Related U.S. Application Data

(60) Provisional application No. 60/825,791, filed on Sep. 15, 2006.

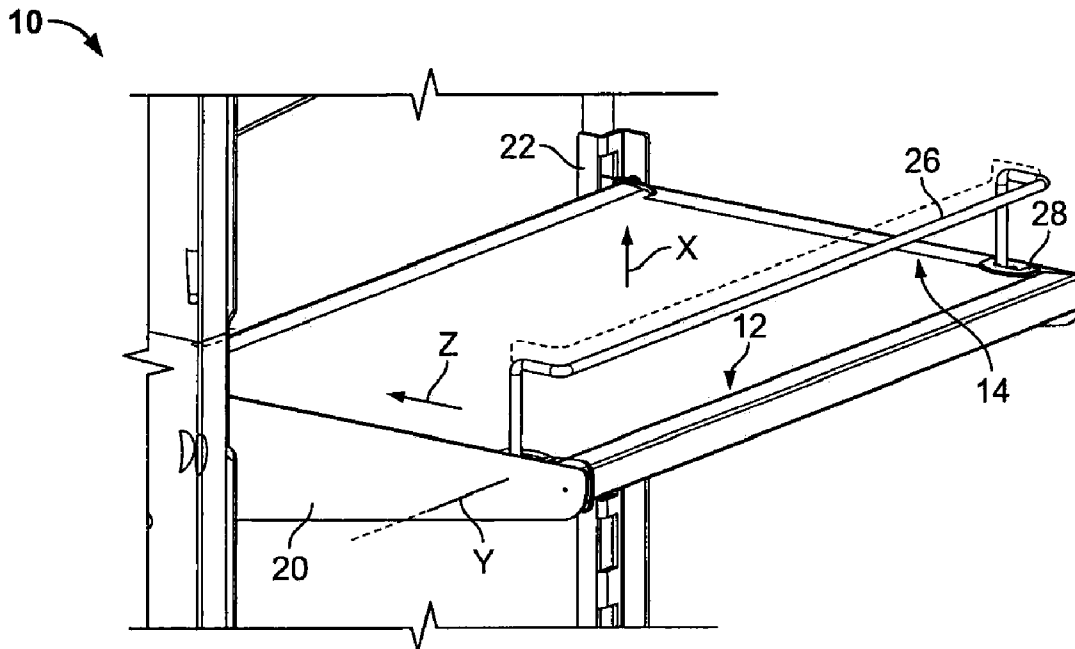

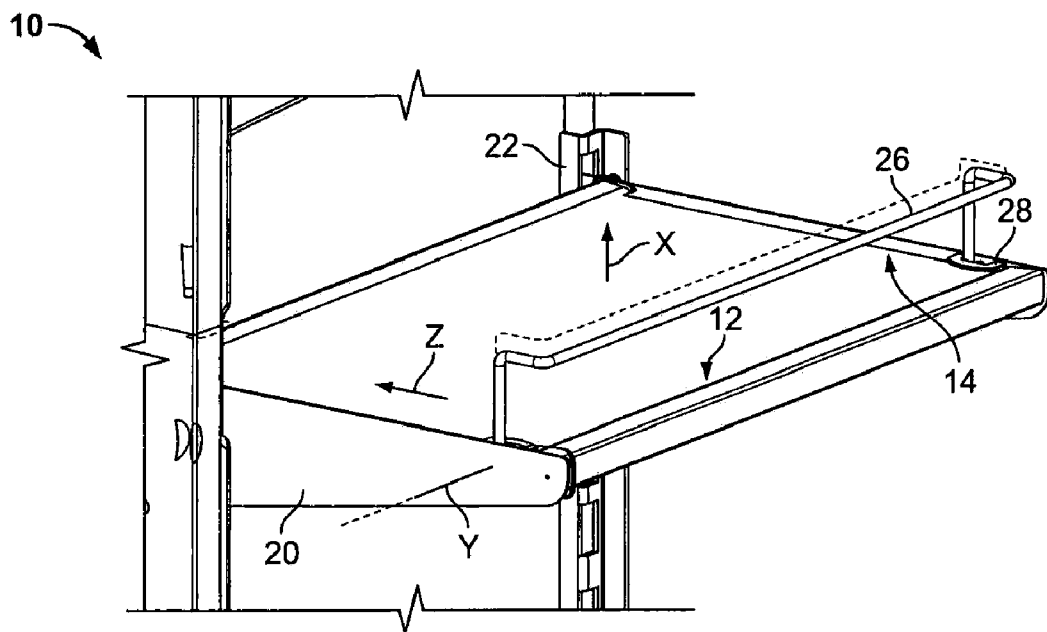

FIG. 1

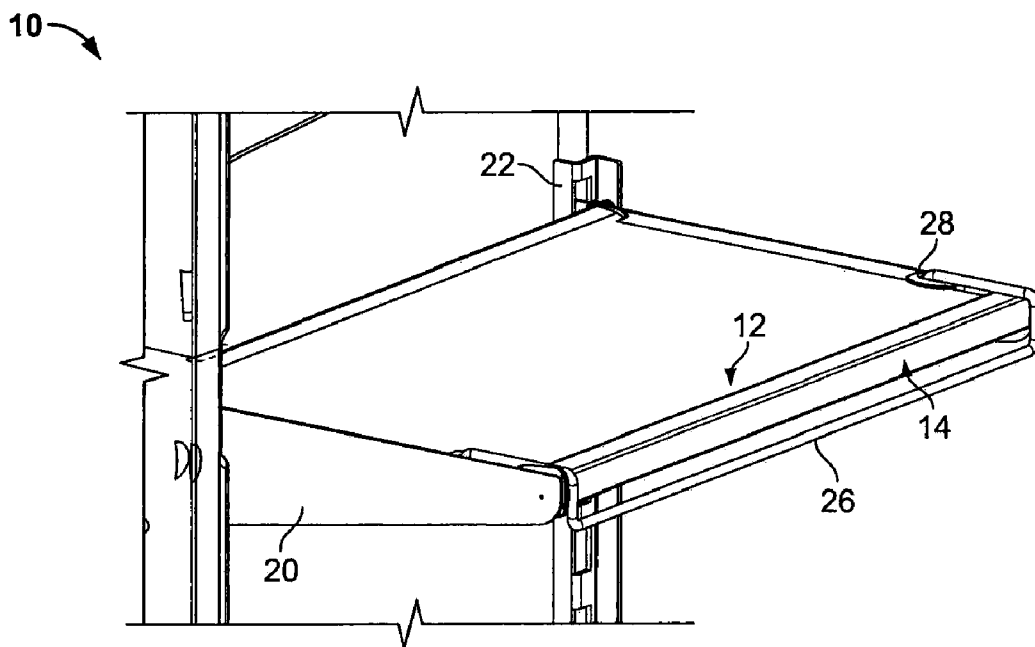

FIG. 2

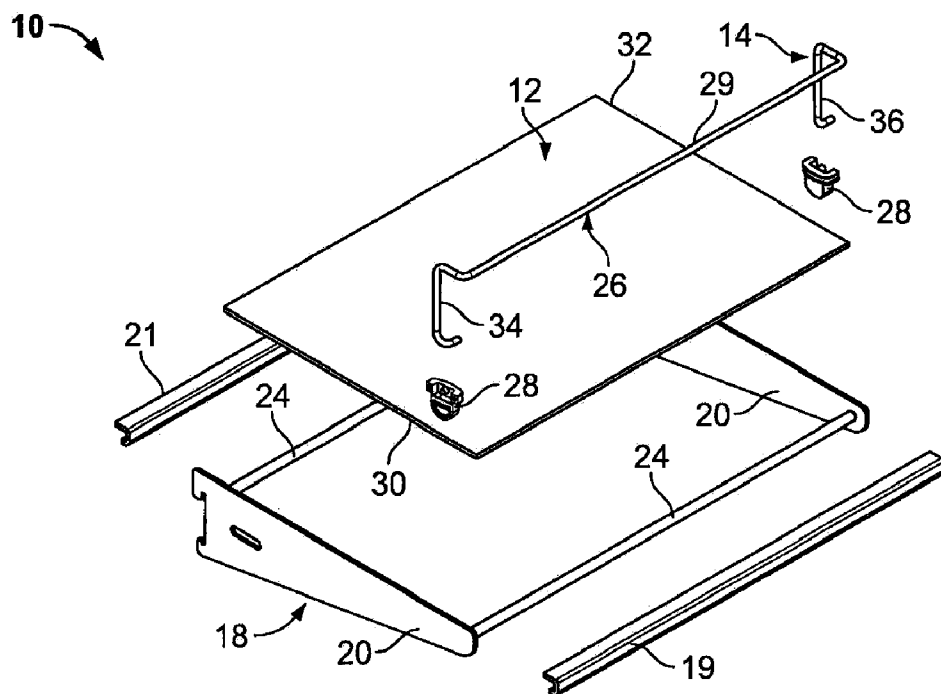

FIG. 3

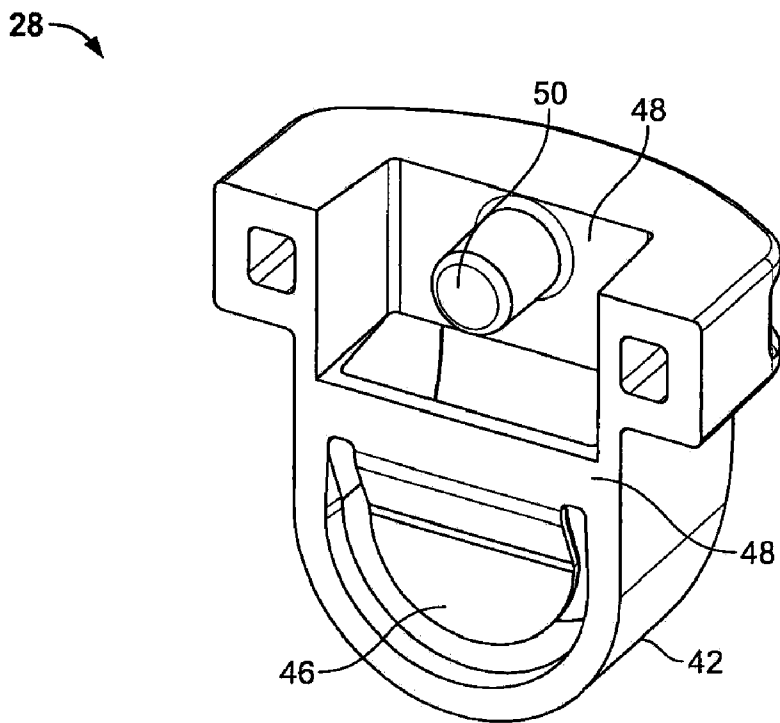

FIG. 4

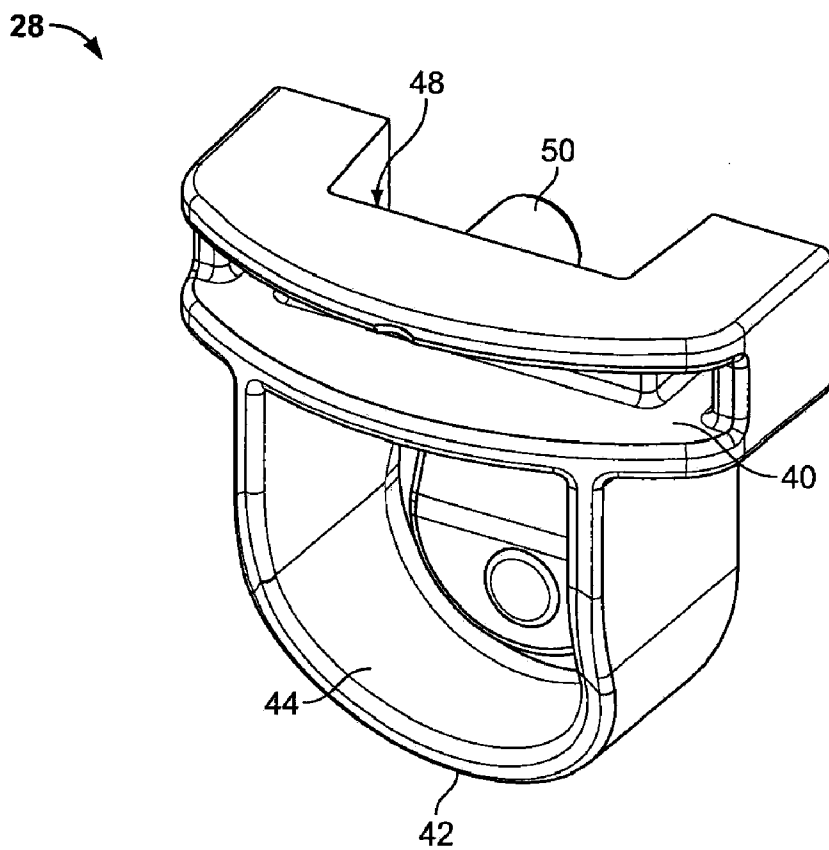

FIG. 5

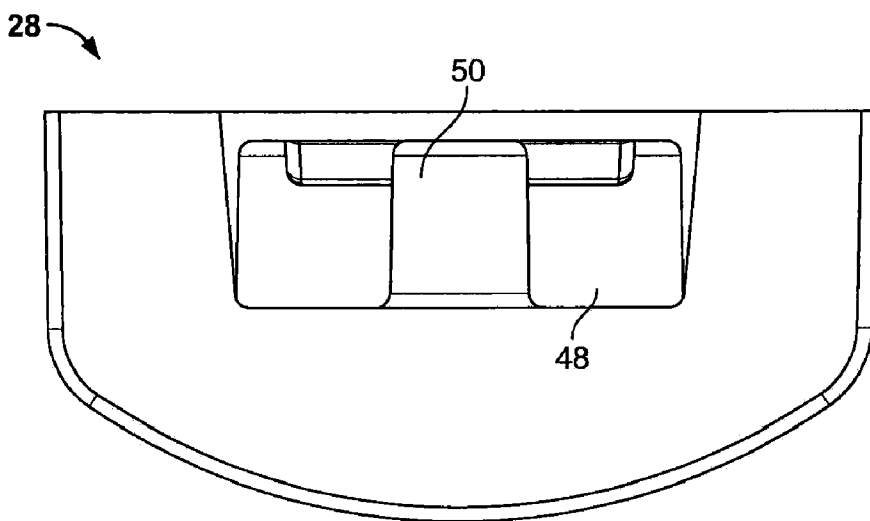
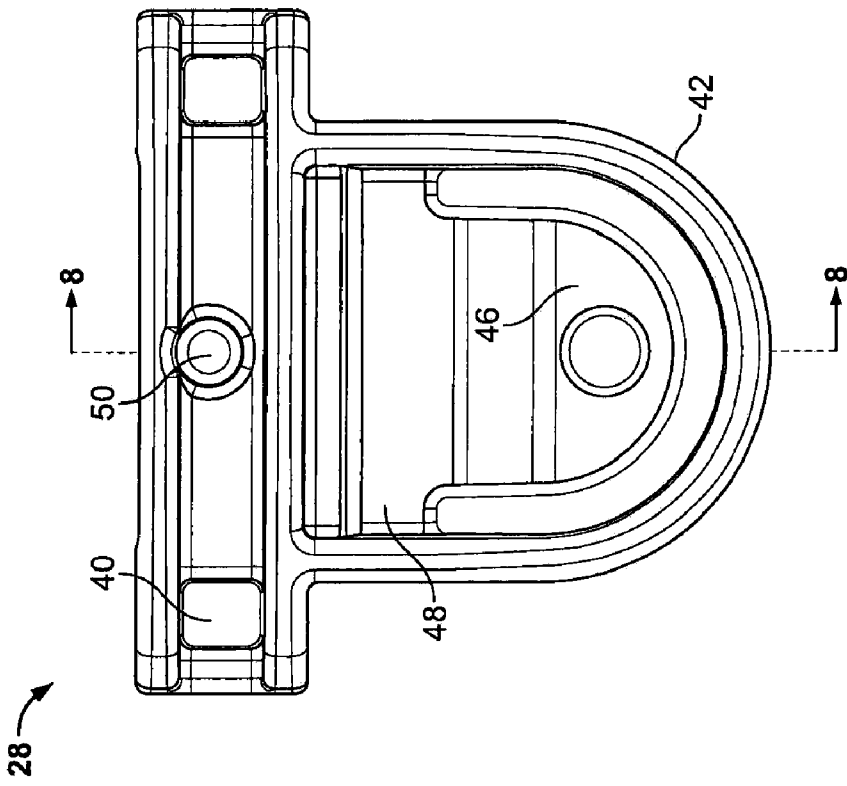
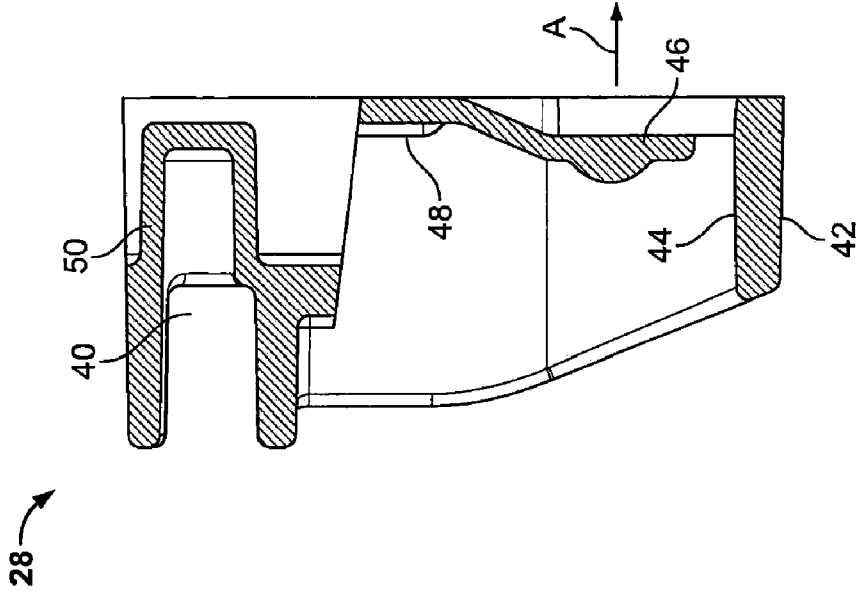

FIG. 6



REFRIGERATOR SHELVING SYSTEM WITH ITEM RETAINER

CROSS-REFERENCE TO RELATED APPLICATIONS

[0001] This application claims priority to U.S. Provisional Patent Application No. 60/825,791 filed 15 Sep. 2006, which application is herein expressly incorporated by reference.

FIELD

[0002] The present teaching relate generally to refrigerators. More particularly, the present teaching to a shelving system for a refrigerator having an item retainer.

BACKGROUND

[0003] The statements in this section merely provide background information related to the present disclosure and may not constitute prior art.

[0004] Refrigerators are commonly used for both stationary and mobile applications. Some known shelving systems for mobile applications incorporate item retention features. While such conventional refrigerator shelving arrangements have proven to be satisfactory for their intended uses, they are all associated with limitations. For example, known shelving arrangements do not adequately secure items within the refrigerator for vehicle movement. Furthermore, many known item retention features are limited for use with wire shelves.

[0005] Accordingly, it remains a need in the pertinent art to provide a shelving system for a vehicle refrigerator that overcomes the limitations associated with prior known arrangements, including but not limited to those disadvantages discussed above.

SUMMARY

[0006] According to one aspect, the present teachings provide a retention system for a shelf of a refrigerator. The shelf generally defines a horizontal plane and includes first and second lateral sides. The retention system may include a retainer member and at least one connector member. The retainer member may extend between the first and second lateral sides of the shelf and may include a central portion positionable above the shelf. The at least one connector member may connect the retainer member to the shelf. The at least one connector member may include a locking mechanism for securing the retainer member at various points along a length of at least one of the lateral sides of the shelf.

[0007] According to another aspect, the present teachings provide a shelving arrangement for a refrigerator. The shelving arrangement includes a shelf generally defining a horizontal plane. The shelving arrangement may additionally include a retainer member extending between the first and second lateral sides of the shelf. The retainer member may include a central portion positionable above the shelf. The shelving arrangement may further include a first connector member coupling the retainer member to the first lateral side of the shelf and a second connector member coupling the retainer member to the second lateral side of the shelf.

[0008] Further areas of applicability of the present teachings will become apparent from the detailed description provided hereinafter. It should be understood that the detailed description and specific examples, while indicating

the preferred embodiment of the invention, are intended for purposes of illustration only and are not intended to limit the scope of the invention.

DESCRIPTION OF THE DRAWINGS

[0009] The present invention will become more fully understood from the detailed description and the accompanying drawings, wherein:

[0010] FIG. 1 is a perspective view of a shelving arrangement for a refrigerator in accordance with the present teachings, a retaining member of the shelving arrangement shown in a deployed position (solid lines) and an intermediate position (hidden lines).

[0011] FIG. 2 is a perspective view of a shelving arrangement for a refrigerator in accordance with the present teachings similar to FIG. 1, the retaining member of the shelving arrangement shown in a stowed position.

[0012] FIG. 3 is an exploded perspective view of a shelving arrangement for a refrigerator in accordance with the present teachings.

[0013] FIG. 4 is an enlarged perspective view of a first side of a connector member in accordance with the present teachings.

[0014] FIG. 5 is an enlarged perspective view of a second side of a connector member in accordance with the present teachings.

[0015] FIG. 6 is top view of a connector member in accordance with the present teachings.

[0016] FIG. 7 is a plan view of a first side of a connector member in accordance with the present teachings.

[0017] FIG. 8 is a cross-sectional view taken along the line 8-8 of FIG. 7.

DESCRIPTION OF VARIOUS ASPECTS

[0018] The following description the present teachings is merely exemplary in nature and is in no way intended to limit the invention, its application, or uses.

[0019] With general reference to the drawings, a shelving system constructed in accordance with the present teachings is illustrated and generally identified at reference character 10. In one application, the shelving system 10 is for a refrigerator. It will become apparent, however, that the present teachings may be used for other applications.

[0020] The shelving arrangement 10 of the present teachings may generally include a shelf 12 and a retention system or arrangement 14. As will be appreciated below, the retention system 14 may be operative to retain items on the shelf 12. In one particular application, the retention system 14 may serve to retain food and other items on a shelf 12 of a vehicle refrigerator in response to movement of the vehicle. The retention system 14 retains the items on the shelf 12 by establishing a barrier which prevents the items from forwardly moving off the shelf. Lateral movement of the items from the shelf 12 may be prevented by the refrigerator sidewalls, for example.

[0021] The shelf may be a solid shelf 12 constructed of glass, acrylic, plastic or other suitable materials. In alternative applications, the shelf may be a wire shelf. The shelf 12 may further include a first trim piece 19 and a second trim piece 21. The first and second trim pieces 19 and 21 may be constructed of plastic. The first and second trim pieces may define channels for receiving edges of the shelf 12.

[0022] The shelf 12 may be supported by a support arrangement 18. The support arrangement 18 may include a pair of arms 20 that selectively engage uprights 22 and a pair of transverse members 24 extending between the arms 20. The transverse members 24 may be received within channels defined by the trim pieces 19 and 21.

[0023] The retention system 14 may generally include a retainer member 26 and at least one connector member 28 for coupling the retainer member to the shelf 12. As shown in the drawings, the at least one connector member may include first and second connector members 28. The first and second connector members 28 may be substantially identical to one another. The connector members 28 may be formed of plastic or other suitable material.

[0024] The retainer member 26 may include a central portion 29 that substantially extends between first and second lateral sides 30 and 32 of the shelf 12. The central portion 29 may extend across the shelf 12 in a substantially linear manner. The retainer member 26 may additionally include first and second end portions 34 and 36. The first and second end portions 34 and 36 may be substantially identical and may include upper portions that depend from the central portion 29. These upper portions may extend rearwardly from the central portion 29 when the retainer member 26 is in a deployed position (as shown in solid lines in FIG. 1, for example). Intermediate portions of the first and second end portions 34 and 36 downwardly extend to hooked-shaped lower portions. The retainer member 26 may be unitarily formed of metal rod stock. Alternatively, the retainer member 26 may be formed of plastic.

[0025] The connector members 28 couple the retainer member 26 to the shelf 12. Prior to addressing the construction and function of the connector members 28, an understanding of the resulting movement allowed by the connector members 28 between the shelf 12 and the retainer member 26 is warranted. The retainer member 26 may be rotatably moved between a deployed position (shown in FIG. 1 in solid lines) and a stowed position (shown in FIG. 2). The retainer member 26 may also be upwardly translated from the deployed position to an intermediate position (shown in FIG. 1 in dashed lines). The retainer member 26 may be secured relative to the shelf 12 at various positions along the length of the first and second lateral sides 30 and 32.

[0026] Each of the connector members 28 include a first side (shown in the perspective view of FIG. 4) that faces the shelf and an opposite second side (shown in the perspective view of FIG. 5). The connector members 28 may additionally include a top portion and a bottom portion. At the top portion, the first side of the connector member 28 may define a channel 40. In this regard, the top portion may include a pair of spaced flanges to define the channel 40. The channel 40 may slidably receive a side of the shelf 12.

[0027] The lower portion of the connector member 28 may include a wall 42 with a bottom portion that is curved such that the wall defines a generally U-shaped channel 44. As will be discussed below, the U-shaped channel 44 receives the lower portion of one of the ends 34 and 36 of the retainer member 26. The lower portion may further include a stop member 46. The stop member 46 may be connected to the wall 42 through a horizontally extending web 48.

[0028] At the second side, the top of the connector member 28 defines an opening 48. The opening 48 leads to the

channel 44. A pin 50 may be integrally formed with the upper portion and may extend into the opening 48.

[0029] The lower hook portions of the first and second ends 34 and 36 of the retainer member 26 pass through the openings 48 of the respective connector members 28. After the connector members 28 are selectively positioned along the lateral sides 30 and 32 of the shelf 12 to in desired positions, the retainer member 26 is downwardly translated to the deployed position (shown in solid lines in FIG. 1). In this position, the hook portions of the first and second ends 34 and 36 are seated in the channels 44 of the respective connector members 28. Rotation of the retainer member 26 is precluded through contact between the lower hook portions and the wall 42.

[0030] When the lower hook portions are seated in their respective connector member channels 44, the stop portions 46 are urged by the lower hook portions against an inherent spring bias and into contact with the shelf 12. Through friction, this contact may prevent sliding movement between the connector member 28 and the shelf 12 and thereby fix the position of the retainer member 26 relative to the shelf 12. In certain applications, it may be desirable to provide the stop portions 46 with cooperating structure to further preclude movement relative to the shelf 12. For example, cooperating teeth may be carried by the stop portion 46 and the shelf 12.

[0031] When the retainer member 26 is translated upwardly (in the direction indicated by Arrow X in FIG. 1), the lower hook portion of each end 34 and 36 is displaced from the U-shaped channel 44. This upward translation is limited by engagement of the respective pins 50 with the lower hook portions. The retainer member 26 may now be rotated about an Axis Y (see FIG. 1) that passes generally through the pins 50 to the stowed position (see FIG. 2). The retainer member 26 may also be translated in the direction of Arrow Z (see FIG. 1) along the shelf 12 as the stop portions 46 are no longer pressed against the shelf 12 by the lower hook portions. Through this translation in the direction of Arrow Z, the position of the retainer member 26 may be adjusted depending on the amount of items present on the shelf 12. In this manner, the items on the shelf may be effectively captured between the retainer member 26 and the refrigerator sidewalls.

[0032] It will now be appreciated that a refrigerator shelving system 10 is provided that provides a retainer member 26 which can be employed at various points along a shelf 12. Additionally, the present teachings provide a retainer system 14 that may be utilized with a solid shelf 12.

[0033] The description of the invention is merely exemplary in nature and, thus, variations that do not depart from the gist of the invention are intended to be within the scope of the invention. Such variations are not to be regarded as a departure from the spirit and scope of the invention.

What is claimed is:

1. A retention system for a shelf of a refrigerator, the shelf generally defining a horizontal plane and include first and second lateral sides, the retention system comprising:

a retainer member for extending between the first and second lateral sides of the shelf, the retainer member including a central portion positionable above the shelf; and

at least one connector member for connecting the retainer member to the shelf, the at least one connector member including a locking mechanism for securing the retainer

member at various points along a length of at least one of the lateral sides of the shelf.

2. The retention system for a shelf of a refrigerator of claim 1, wherein the at least one connector member includes a first connector member for connecting the retainer member to the first lateral side and a second connector member for connecting the retainer member to the second lateral side.

3. The retention system for a shelf of a refrigerator of claim 2, wherein the at least one connector member is operable in a first mode to permit sliding movement of the at least one connector member relative to the shelf and operative in a second mode to prevent sliding movement of the at least one connector member relative to the shelf.

4. The retention system for a shelf of a refrigerator of claim 1, wherein the at least one connector member defines a channel for slidably receiving one of the first and second lateral sides of the shelf.

5. The retention system for a shelf of a refrigerator of claim 1, wherein the at least one connector member includes a stop member moveable between a first position and a second position such that relative movement between the retainer member and the shelf is permitted in the first position and relative movement between the retainer member and the shelf is prevented in the second position.

5. The retention system for a shelf of a refrigerator of claim 5, wherein the retainer member is moveable from a first position to second position to move the stop member from the first position to the second position.

6. The retention system for a shelf of a refrigerator of claim 5, wherein the stop member frictionally engages the shelf to prevent relative movement between the retainer member and the shelf.

7. The retention system for a shelf of a refrigerator of claim 5, wherein the stop member is elastically moveable from the first position to the second position.

8. The retention system for a shelf of a refrigerator of claim 1, wherein the retainer member is rotatable about a laterally extending axis.

9. The retention system for a shelf of a refrigerator of claim 1, in combination with the shelf.

10. The retention system for a shelf of a refrigerator of claim 1, in combination with the shelf and the refrigerator.

11. A shelving arrangement for a refrigerator, the shelving arrangement comprising:

- a shelf generally defining a horizontal plane;
- a retainer member for extending between the first and second lateral sides of the shelf, the retainer member including a central portion positionable above the shelf; and
- a first connector member coupling the retainer member to the first lateral side of the shelf; and
- a second connector member coupling the retainer member to the second lateral side of the shelf.

12. The shelving arrangement for a refrigerator of claim 11, wherein the at least one of the first and second connector members are operable in a first mode to permit sliding movement of the at least one connector member relative to the shelf and operative in a second mode to prevent sliding movement of the at least one connector member relative to the shelf.

13. The shelving arrangement for a refrigerator of claim 11, wherein at least one of the first and second connector members defines a channel for slidably receiving a corresponding one of the first and second lateral sides of the shelf.

14. The shelving arrangement for a refrigerator of claim 11, wherein at least one of the first and second one connector members includes a stop member moveable between a first position and a second position such that relative movement between the retainer member and the shelf is permitted in the first position and relative movement between the retainer member and the shelf is prevented in the second position.

15. The shelving arrangement for a refrigerator of claim 14, wherein the retainer member is moveable from a first position to second position to move the stop member from the first position to the second position.

16. The shelving arrangement for a refrigerator of claim 14, wherein the stop member frictionally engages the shelf to prevent relative movement between the retainer member and the shelf.

17. The shelving arrangement for a refrigerator of claim 14, wherein the stop member is elastically moveable from the first position to the second position.

18. The shelving arrangement for a refrigerator of claim 11, wherein the shelf is a solid shelf.

20. A shelving arrangement for a refrigerator, the shelving arrangement comprising:

- a solid shelf generally defining a horizontal plane;
- a retainer member for extending between the first and second lateral sides of the shelf, the retainer member including a central portion positionable above the shelf; and

first and second connector members respectively coupling the retainer member to the first and second lateral sides of the shelf, each connector member including a first side for slidably receiving the respective lateral side of the shelf and a second side for receiving one of the ends of the retainer member, each connector member further including a stop member for limiting upward translation of the retainer member, the stop members of the first and second connector members cooperating to define a pivot axis about which the retainer member may rotate.

* * * * *