

(19) World Intellectual Property
Organization
International Bureau



(43) International Publication Date
6 May 2004 (06.05.2004)

PCT

(10) International Publication Number
WO 2004/037125 A1

- (51) International Patent Classification⁷: **A61F 2/04**
- (21) International Application Number:
PCT/US2003/032286
- (22) International Filing Date: 10 October 2003 (10.10.2003)
- (25) Filing Language: English
- (26) Publication Language: English
- (30) Priority Data:
10/277,575 22 October 2002 (22.10.2002) US
- (71) Applicant: **SCIMED LIFE SYSTEMS, INC.** [US/US];
One SciMed Place, Maple Grove, MN 55311-1566 (US).
- (72) Inventor: **GELLMAN, Barry**; 19 Pebble Brook Road,
Easton, MA 02356 (US).
- (74) Agent: **FORCIER, John, V.**; Testa, Hurwitz & Thibeault,
LLP, High Street Tower, 125 High Street, Boston, MA
02110 (US).
- (81) Designated States (*national*): AE, AG, AL, AM, AT, AU,
AZ, BA, BB, BG, BR, BY, BZ, CA, CH, CN, CO, CR, CU,
CZ, DE, DK, DM, DZ, EC, EE, EG, ES, FI, GB, GD, GE,
GH, GM, HR, HU, ID, IL, IN, IS, JP, KE, KG, KP, KR,
KZ, LC, LK, LR, LS, LT, LU, LV, MA, MD, MG, MK,
MN, MW, MX, MZ, NI, NO, NZ, OM, PG, PH, PL, PT,
RO, RU, SC, SD, SE, SG, SK, SL, SY, TJ, TM, TN, TR,
TT, TZ, UA, UG, UZ, VC, VN, YU, ZA, ZM, ZW.
- (84) Designated States (*regional*): ARIPO patent (GH, GM,
KE, LS, MW, MZ, SD, SL, SZ, TZ, UG, ZM, ZW),
Eurasian patent (AM, AZ, BY, KG, KZ, MD, RU, TJ, TM),
European patent (AT, BE, BG, CH, CY, CZ, DE, DK, EE,
ES, FI, FR, GB, GR, HU, IE, IT, LU, MC, NL, PT, RO,
SE, SI, SK, TR), OAPI patent (BF, BJ, CF, CG, CI, CM,
GA, GN, GQ, GW, ML, MR, NE, SN, TD, TG).
- Published:**
— with international search report
- For two-letter codes and other abbreviations, refer to the "Guidance Notes on Codes and Abbreviations" appearing at the beginning of each regular issue of the PCT Gazette.*

(54) Title: MALE URETHAL STENT DEVICE

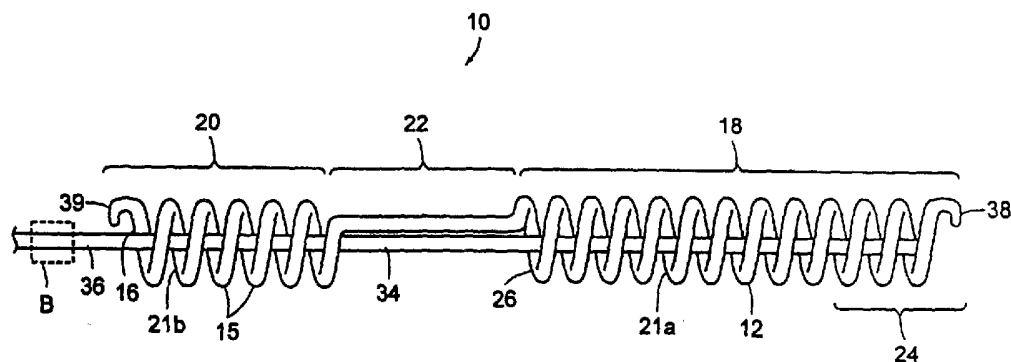

(57) Abstract: A stent for treatment of a body lumen through which a flow is effected on either side of a sphincter, said stent comprising one or more windings and having an inner core substantially covered by an outer core and including a first segment, a second segment, and a connecting member disposed between the segments. When the stent is positioned within a patient's urinary system, the first segment and second segments are located on either side of the external sphincter to inhibit migration of the stent while not interfering with the normal functioning of the sphincter. The outer coating comprises an absorbable material that provides temporary structural support to the stent. After absorption of substantially all the outer coating of the stent, the remaining relatively compliant inner core facilitates easy removal by the patient by pulling a portion of the stent that extends outside the patient's body for this purpose.

WO 2004/037125 A1

MALE URETHRAL STENT DEVICETechnical Field

[0001] This invention generally relates to stents and maintaining a body passageway open.

Background Information

[0002] Bladder outlet obstruction is a urological disorder. In males, this urological disorder can be caused by an enlarged prostate that constricts the prostatic urethra. Such disorders include, for example, benign prostatic hyperplasia or prostatic carcinoma. The prostatic urethra is a section of the urethra that passes through the prostate. Bladder outlet obstruction is associated with a plurality of undesirable symptoms such as difficulties in urination, strongly reduced capacity to urinate, an increased desire to urinate, or the complete inability to urinate which may lead to severe renal disorders.

10 [0003] To eliminate these symptoms, medical devices that attempt to maintain an open passageway through the prostatic urethra have been developed. One of the medical devices developed for this purpose is a Foley catheter. The Foley catheter is a tube that extends from the patient's bladder to a collection bag located outside of the patient's body. The Foley catheter provides constant drainage, but it does not allow the patient to control his voiding function.

15 [0004] Some indwelling prostatic stents seek to allow the patient to control their voiding function while also retaining the prostatic urethra open. For example, U.S. Patent No. 5,766,209 describes a prosthesis that contains two tubular elements that are intended to be located on either side of the patient's external sphincter, and a connector that is intended to be held in the orifice of the external sphincter.

[0005] Following conclusion of the treatment of the urological disorder (for example, when patency of the urethra is restored), a medical professional is generally required to remove an indwelling prostatic stent either transurethreally or endoscopically. A partially absorbable stent which can be implanted following a surgical procedure and be easily removed by the patient
5 would obviate the need for a patient to return to the doctor for removal of the stent.

Summary of the Invention

[0006] The invention generally relates to draining fluid from the bladder of a patient with a stent. Devices and methods according to the invention are typically used in the treatment for patients suffering from bladder outlet obstruction to address and relieve urinary retention. It is
10 an object of the invention to maintain the urethra open and able to pass fluids from the bladder while also allowing normal operation of the patient's external sphincter such that the patient has control over the retention and discharge of urine (and/or other fluids) from the bladder. It is another object of the invention to resist migration of a device placed within the patient's urinary system, and also to prevent or reduce the attraction of blood clots (and/or other debris) when the
15 device is placed and used within the patient. It is a further object of the invention to permit ease of removal of the device by the patient when patency of the lumen is restored.

[0007] It is noted initially that the directional terms proximal and distal require a point of reference. As used herein, the point of reference is from the perspective of the body of the patient. Therefore, the term proximal refers to a direction that points into the body of the patient,
20 whereas the term distal refers to a direction that points out of the patient's body.

[0008] In one aspect, the invention features a medical device for use within a body lumen of a patient comprising a first coil, a second coil, and a connecting segment. When placed within the body of the patient the first coil comprises a plurality of windings defining a first lumen and locatable on the proximal side of the external sphincter and a distal end terminating on the

proximal side of the external sphincter. The second coil comprises a plurality of windings defining a second lumen and locatable on the distal side of the external sphincter and a proximal end terminating on the distal side of the external sphincter. The connecting segment is locatable in the external sphincter when the device is placed within the body of the patient and is disposed
5 between and couples together the first and second coils. The medical device can have a removal segment attached to a proximal end of the first coil. The removal segment can be disposed within the first lumen and/or the second lumen.

[0009] In one embodiment, the first coil, the second coil, and the connecting segment further comprise an inner core and an outer coating covering at least a portion of the inner core. The
10 inner core may be formed from a biocompatible material. In one embodiment, the outer coating is formed from a material that is absorbed into the lumen of a patient at a predetermined degradation rate. The outer coating may be formed from polyglycolic acid, polylactic acid, a polymer, or a polyimid. The outer coating may also comprise a pharmaceutical.

[0010] In another embodiment, the windings of the first coil and the second coil are sized and
15 configured to progressively uncoil from the proximal end of the first coil to a distal end of the second coil upon application of a continuous tensile force to the removal segment. The proximal end of the first coil may be formed into a variety of shapes to permit atraumatic entry of the medical device into the body of the patient. In one embodiment, the proximal end of the first coil is a frusto-conical shape. In another embodiment, the proximal end of the first coil and the
20 distal end of the second coil include one or more hooks to permit connection to a delivery system.

[0011] In one embodiment, the windings of the first coil and the second coil are separated from each other by a distance in the range of from about 0.5 millimeters to about 10 millimeters.

In one embodiment, the cross-sectional area of the outer coating is in the range from about 0.0079 millimeters² to about 7.1 millimeters².

5 [0012] Another aspect of the invention features a medical device for use within a body lumen of a patient comprising an inner core and an outer coating layered upon a portion of the inner core. The inner core includes a first coil defining a first lumen and having a proximal end and a distal end. The inner core also includes a second coil defining a second lumen having a proximal end and a distal end. The outer coating provides structural support to the first lumen and the second lumen of the inner core when placed with a body lumen of a patient. The inner core further comprises a plurality of spaced coil windings being sized and configured for placement and retention substantially within the urethra of a patient. A connecting segment is disposed between and couples together the first coil and the second coil. In one embodiment, the medical device is of unitary construction. The medical device can also have a removal segment attached to the proximal end of the first coil. The removal segment can be disposed within the first lumen and/or the second lumen.

15 [0013] The inner core may be formed from a biocompatible material. The outer coating may be formed from a material that loses structural integrity during hydration and may be absorbed into the lumen of a patient at a predetermined degradation rate. The outer coating may be formed from polyglycolic acid, polylactic acid, a polymer, or a polymid. The outer coating may also comprise a pharmaceutical.

20 [0014] In another embodiment, the windings are sized and configured to progressively uncoil from the proximal end of the first coil to the distal end of the second coil upon application of a continuous tensile force to the removal segment. The proximal end of the first coil may be formed into a variety of shapes to permit atraumatic entry of the medical device into the body of the patient. In one embodiment, the proximal end of the first coil is a frusto-conical shape. In

another embodiment, the proximal end of the first coil and the distal end of the second coil includes one or more hooks to permit connection to a delivery system. In one embodiment, the windings of the first coil and the second coil are separated by a distance in the range of from about 0.5 millimeters to about 10 millimeters. In one embodiment, the cross-sectional area of the outer coating is in the range of from about 0.0079 millimeters² to about 7.1 millimeters².

[0015] Another aspect of the invention features a method of maintaining the patency of a patient's urethra. The method includes supporting the prostatic section of a the urethra with a first coil defining a first lumen and locatable on the proximal side of the external sphincter, supporting the bulbar section of a the urethra with a second coil defining a second lumen and locatable on the distal side of the external sphincter, and permitting substantially normal constriction of the external sphincter with a substantially uncoiled segment coupling the first coil and second coil.

[0016] The method can include providing a delivery system comprising a first element and a second element. The first element has an outer diameter smaller than the diameters of the first coil and the second coil and includes a first end, a second end, and a connection member extending out from the first end. The second element includes a first end, a second end, and a connection member extending out from the first end with the first and/or the second elements of the delivery system being rotatable. In one embodiment, the connection member of the first element comprises an arm extending radially outward from the first end and includes an opening sized to receive a hook extending from the proximal portion. In another embodiment, the connection member of the second element comprises an arm extending radially outward from the first end and includes an opening sized to receive the hooks extending from the proximal portion of the first segment and the distal end of the second segment.

[0017] The foregoing and other objects, aspects, features and advantages of the present invention will be more fully understood from the following description and embodiments when read together with the accompanying drawings.

Brief Description of Drawings

- 5 [0018] In the drawings, like reference characters generally refer to the same parts throughout the different views. Also, the drawings are not necessarily to scale, emphasis instead generally being placed upon illustrating the principles of the invention.
- [0019] FIG. 1A is a side view of one embodiment of a prostatic stent according to the invention.
- 10 [0020] FIG. 1B shows an enlarged perspective view of a representative section of the coil segment labeled B in FIG. 1A.
- [0021] FIG. 1C shows an enlarged cross-sectional view taken along a line C—C in FIG. 1B.
- [0022] FIG. 1D shows an enlarged view of the proximal end of the stent in FIG. 1A.
- [0023] FIG. 2 is a side view of a prostatic stent including a frusto-conical proximal tip.
- 15 [0024] FIG. 3 is a side view of a one embodiment of a delivery system.
- [0025] FIG. 4A is a schematic view of the prostatic stent connected to the delivery system depicted in FIG. 3.
- [0026] FIG. 4B is a schematic view of the prostatic stent connected to the delivery system depicted in FIG. 3 and in a configuration for insertion into the urethra of the patient.
- 20 [0027] FIG. 5A is an expanded schematic view of a prostatic stent being inserted into the male patient's urinary system using the delivery system depicted in FIG. 3.

[0028] FIG. 5B is an expanded schematic view of a clinical application of a prostatic stent properly positioned in a male patient's urinary system.

[0029] FIG. 6A is a view of a male patient's urinary system.

[0030] FIG. 6B is a view of the prostatic stent implanted in a male patient's urinary system.

5 [0031] FIG. 7A is a side view of a prostatic stent properly being removed and uncoiled.

[0032] FIG. 7B is a side view of a prostatic stent being further removed and uncoiled.

[0033] FIG. 7C is a schematic view of a prostatic stent being removed from the male patient's urinary system.

Description

10 [0034] The invention generally relates to relieving urinary retention. The invention provides devices and methods for assisting urinary release in a male patient suffering from bladder outlet obstruction while allowing normal functioning of the patient's external sphincter such that the patient has control over bladder voiding.

15 [0035] Some men, especially men over fifty years of age, experience urinary retention caused by an enlarged prostate. The prostate is a chestnut shaped organ that surrounds the urethra in a man's urinary system. When it becomes enlarged due to disease or changes in male hormone production, the prostate can constrict the urethra resulting in bladder outlet obstruction. The medical condition described above is generally referred to as benign prostatic hyperplasia
20 (BPH). In addition to the obstruction caused by the enlarged prostate, blood clots or other debris collecting in the constricted urethra may further obstruct the urethra of a patient suffering from BPH. One of the objects of the invention is to maintain an open passageway clear of debris from the patient's bladder through the urethra while preserving the patient's normal control of voiding

function by allowing the external sphincter to open and close normally and under patient control. A further object of the invention is to permit practical removal of the device by the patient, thereby avoiding the cost and inconvenience of returning to a medical practitioner's office following the conclusion of treatment of the urological disorder.

5 [0036] Referring to FIG. 1A, the prostatic stent 10, in accordance with an embodiment of the invention, comprises an elongate coil segment 12 extending substantially longitudinally and including two distinct layers. As depicted in FIGS. 1B and 1C, the coil segment 12 of prostatic stent 10 comprises an inner core 13 surrounded by an outer coating 14 of thickness W. In other
10 embodiments (not shown), the outer coating 14 may only partially surround the inner core 13. The inner core 13 is made from one or more biocompatible materials such as a polyimide. The outer coating 14 is made of a material which can be absorbed into the body and which provides the rigid support for the stent 10 when implanted in the male urinary system. The outer coating 14 is preferably a polyglycolic acid, polylactic acid, or a polymer blend, for example. In general, any biocompatible and bio-absorbable material(s) capable of providing rigid support for the stent
15 10 can be used for the outer coating 14.

[0037] The coil segment 12 is wound to form a plurality of windings 15 spaced from each other along some of the length of the coil segment 12. The plurality of windings 15 form a first coil (or prostatic segment) 18 and a second coil (or bulbar segment) 20. The windings 15 along the prostatic segment 18 defines a first lumen 21a and the windings 15 along the bulbar segment
20 20 defines a second lumen 21b. The first lumen 21a and second lumen 21b extend longitudinally along the prostatic stent 10 to allow fluid(s), such as urine, to pass therethrough. The prostatic segment 18 and the bulbar segment 20 are coupled together by a substantially unwound section along the coil segment 12 that defines a connecting segment 22.

[0038] The windings 15 of those sections of the stent 10 are sufficiently flexible to conform to the shape of the urethra for ease of insertion while sufficiently rigid to maintain an open passageway through the urethra when placed in the male urinary system. The segments 18, 20 can have cross-sectional shapes that are circular or can have other cross-sectional shapes, such as elliptical or even rectangular, square, or triangular, for example. In the embodiment of FIG. 1A, the prostatic stent 10 includes a proximal tip 24 extending proximally from the prostatic segment 18. An end view of the prostatic stent 10 at the proximal tip 24 is depicted in FIG. 1D. The connecting segment 22 connects to the prostatic segment 18 at a distal end 26. The proximal tip 24 can be either of constant diameter as shown in FIG. 1A, or a tapered diameter as shown in FIG. 2, yielding a conical or frusto-conical shape providing an atraumatic tip for ease of insertion into the patient's urethra. The first lumen 21a extends through the prostatic segment 18 to the proximal tip 24 for fluidic communication with the bladder of the patient.

[0039] A removal segment 34 continues from the proximal tip 24, through the prostatic segment 18, along the connecting segment 22, and through the bulbar segment 20, such that a distal portion 36 of the removal segment 34 may extend outside the penis when the prostatic stent 10 is implanted in the male urinary system. In one embodiment, the prostatic stent 10 is manufactured by heat setting the inner core 13 comprising the polyimide material in the desired coiled configuration defining the prostatic and bulbar segments 18, 20 about a mandrel at approximately 240 degrees Celsius for approximately two hours.

[0040] The prostatic and bulbar segments 18, 20 may also include hooks 38, 39. The hooks 38, 39 are positioned such that the prostatic stent 10 may be connected to a delivery device 40 (see FIG. 3) used to wind the prostatic stent 10 to a smaller width for delivery into the body of the patient. In the embodiment shown in FIG. 1A, the hooks 38, 39 are positioned such that they extend lengthwise beyond the prostatic and bulbar segments 18, 20, respectively. The hooks 38,

39 need not be positioned as shown in FIG. 1A to allow the coil segment 12 to connect to the delivery device 40 as other hook positions are possible.

[0041] When the prostatic stent 10 is properly positioned within a male patient's urinary system, the proximal tip 24 is located within the bladder near the bladder opening, the prostatic segment 18 is located substantially within the prostatic urethra (the section of the urethra that is surrounded by the patient's prostate) with the distal end 26 of the prostatic segment 18 terminating just prior to the proximal side of the patient's external sphincter, and the bulbar segment 20 is located on the distal side of the external sphincter. The connecting segment 22 is sized to extend through the external sphincter to attach the bulbar segment 20 to the prostatic segment 18 while not interfering with the normal operation of the external sphincter. The connecting segment 22 in the embodiment shown in FIG. 1A is substantially an uncoiled portion of coil segment 12. In alternative embodiments, the connecting segment 22 may be a helical coil with a diameter smaller than that of prostatic and bulbar segments 18, 20. Each of the ends of the connecting segment 22 smoothly transitions to the respective prostatic and bulbar segments 18, 20, so as to form no rough discontinuities or edges that would promote the formation of blood clots or collection of other bodily material.

[0042] To retain proper positioning of the prostatic stent 10 when positioned within the patient's body and to inhibit movement, the prostatic and bulbar segments 18, 20 have a greater diameter than connecting segment 22. When properly positioned within the patient's body, the prostatic stent 10 is located substantially within the patient's prostatic urethra with the prostatic segment 18 located within the bladder opening and the bulbar segment 20 located on the proximal side of the patient's external sphincter, so as not to interfere with the normal operation of the external sphincter. The greater diameter of the prostatic and bulbar segments 18, 20 is sized such that prostatic and bulbar segments 18, 20 are in contact with and exert a compressive

force on the patient's urethral wall, thereby anchoring the prostatic stent 10 within the patient's urinary system and preventing the migration of the prostatic stent 10. The greater diameter of the prostatic segment 18 prevents the distal migration of the prostatic stent 10 (down and out of the bladder opening). Similarly, the greater diameter of the bulbar segment 20 prevents the proximal migration of the prostatic stent 10 (up into the bladder of the patient). In one disclosed embodiment, the diameter of the prostatic and bulbar segments 18, 20 is about 40 French.

[0043] FIG. 1C shows an enlarged cross-sectional view of the coil segment 12 taken along a line C—C in FIG. 1B. A dimension labeled W defines the wall thickness of the segment.

Thickness W may be varied to effect the rate of absorption of the outer coating 14. The material composition and heat treatment of the outer coating 14 may also be selected to vary the rate of absorption or degradation.

[0044] The prostatic stent 10 may also include the removal segment 34. The removal segment 34 continues from the proximal tip 24 and is threaded back through the prostatic segment 18, the connecting segment 22, and the bulbar segment 20. The distal portion of the removal segment terminates outside of the patient's body when the prostatic stent 10 is placed within the urinary system of the patient for removal from the patient's body by a medical professional or patient.

After the outer coating 14 is substantially absorbed into the patient's body, the stent 10, comprising now substantially the inner core 13, is sufficiently compliant to permit easy removal. For removal, the patient or medical professional pulls on the distal portion of the removal segment 36 along a longitudinal axis of the stent 10 to progressively unwind the windings 15 of the coil segment 12, enabling the stent 10 to assume a substantially linear configuration for complete withdraw from the patient's body.

[0045] One of the advantageous features of the prostatic stent 10 is its combination of radial strength and flexibility. The spaced windings 15 provide radial strength to the prostatic stent 10,

while permitting the degree of flexibility necessary to conform to the patient's anatomy. In one embodiment the windings 15 are spaced such that a distance of about 1 millimeter exists between each adjacent winding. In other embodiments, where a greater amount of flexibility is desired, the windings 15 may be spaced at a greater distance, such as, for example, up to about 10 millimeters. Alternatively, if a greater amount of strength is required to maintain an open passageway through the patient's prostatic urethra, a medical professional may insert a prostatic stent 10 having windings 15 closely spaced, at a smaller distance. To maintain a desirable amount of flexibility to be able to conform to the patient's anatomy, the windings 15 may be spaced at a distance no less than about 0.5 millimeters.

10 [0046] To wind, insert, position, and deploy the prostatic stent 10, a medical professional, such as, for example, a physician uses the delivery system 40 as shown in FIG. 3. The delivery system 40 can be made from a biocompatible material that is flexible enough to conform to the patient's body, but also rigid enough to advance the prostatic stent 10 through the patient's urinary system.

15 [0047] In the disclosed embodiment, the delivery system 40 includes a rotatable element 42 and has an outer diameter less than the smaller diameter of the prostatic and bulbar segments 18, 20 of the prostatic stent 10 so as to be insertable into the second lumen 21b of the prostatic stent 10. The rotatable element 42 includes a first end 44 having a connection arm 46 that extends radially outward from the first end 44, and a second end 48 that is accessible to the medical professional for positioning the prostatic stent 10 within the urinary system of the patient. The connection arm 46 may pivot about a hinge 50, which attaches the connection arm 46 to the rotatable element 42. The connection arm 46 includes an opening 52 that permits connection between the bulbar segment 20 of the prostatic stent 10 and the rotatable element 42. A stationary element 54 of the delivery system 40 includes a first end 56 having a connection arm

58 and a second end 60. The connection arm 58 extends radially outward from the first end 56 and includes an opening 62, which permits connection between the bulbar segment 18 of the prostatic stent 10 and the stationary element 54. In the disclosed embodiment, the stationary element 54 has an outer diameter larger than the diameter of prostatic and bulbar segments 18, 20 and includes a lumen sized to receive the rotatable element 42.

[0048] FIGS. 4A, 4B show one embodiment of the prostatic stent 10 having windings 15 of the coil segment 12 spaced apart at a large distance, L. Before the prostatic stent 10 is inserted into the patient's urinary system, the width of the winding of the coil segment 12 is reduced to allow the prostatic stent 10 to easily pass through the patient's urethra. One may reduce the width of the prostatic stent 10 to have a largest outer diameter that is in a range between about 16 French to about 18 French. The width of the prostatic stent 10 may be temporarily reduced by twisting or winding the proximal segment 18 about a longitudinal axis while restraining movement of the bulbar segment 20. Alternatively, twisting the bulbar segment 20 about the longitudinal axis while restraining the prostatic segment 18 may also reduce the width of the prostatic stent 10.

[0049] Alternatively, in another embodiment of a delivery system 40, the stationary element 54 may have an outer diameter less than or equal to the diameter of the rotatable element 42 such that the rotatable and stationary elements 42, 54 extend substantially parallel to each other when attached to the prostatic stent 10. In another embodiment, the stationary element 54 may be replaced with another rotatable element. In this embodiment, the two rotatable elements rotate in opposing directions. In a further embodiment, the delivery system 40 may also include a lumen extending through the rotatable element 42 from the first end 44 to the second end 48 to assist a medical professional with placing the prostatic stent 10 with the patient's urinary system.

[0050] Before inserting the prostatic stent 10 in the proper position within the patient's body, either a manufacturer or a medical professional (typically, the manufacturer) uses the stationary and rotatable elements to reduce the outer diameter or width of the prostatic stent 10. By reducing the diameter of the prostatic stent 10, possible injury or bruising to the urethra is substantially prevented during insertion and/or advancement of the prostatic stent 10 through the patient's urinary system. To connect the prostatic stent 10 with the delivery system 40, the manufacturer or medical professional attaches the bulbar segment 20 of the prostatic stent 10 to the first end 44 via the connection arm 46 of the rotatable element 42 and the prostatic segment 18 to the first end 56 via the connection arm 58 of the stationary element 54, as shown in FIG. 4A. In the disclosed embodiment, the connection arms 46, 58 have openings 52, 62 to permit connection to hooks 38, 39 extending from the prostatic and bulbar segments 18, 20 of the prostatic stent 10. Alternatively, the connection arms 46, 58 may be bent into hooks to permit connection with hooks 38, 39. Next, the manufacturer or the medical professional temporarily reduces the diameter of the prostatic stent 10 by twisting or ratcheting the rotatable element 42 that is attached to the prostatic segment 18 of the prostatic stent 10 while simultaneously holding the stationary element 54 that is connected to the bulbar segment 20 of the prostatic stent 10. By twisting the rotatable element 42 in a first direction as shown in FIG. 4B, the width of the prostatic stent 10 has decreased sufficiently to allow passage through the patient's urethra without significantly irritating or bruising the walls of the patient's urethra. As the width of the coil segment 12 is reduced, the length of the coil segment 12 consequently extends in longitudinal length. Upon being released from the delivery system, the coil segment 12 expands and the length of the coil segment 12 contracts until the prostatic stent 10 has returned to substantially its original dimensions.

[0051] With the width of the prostatic stent 10 temporarily reduced, a medical professional inserts the prostatic stent 10 with attached delivery system into the meatus urinarius 62 of the patient, as shown in FIG. 5A. To further protect the patient's urethra from irritation, the medical professional may insert a sheath (not shown) into the patient's urethra 60 prior to inserting the
5 prostatic stent 10 attached to the delivery system 40. The sheath is a smooth tubular member sized to receive the prostatic stent 10 and the delivery system 40. Alternatively, the prostatic stent 10 attached to the delivery system 40 may be inserted into the sheath prior to the medical professional inserting the sheath including the prostatic stent 10 and delivery system 40 into the patient's body.

10 [0052] With continued reference to FIG. 5A, the medical professional advances the prostatic stent 10 and the delivery system 40 through the patient's urinary system until the prostatic stent 10 is located substantially within the prostatic urethra with the prostatic segment 18 located near the opening of the patient's bladder 66 and the bulbar segment terminating prior to the proximal side of the patient's external sphincter 68 so as not to interfere with the normal operation of the
15 external sphincter 68. After confirming proper placement of the prostatic stent 10 using, for example, radiographic techniques, the medical professional returns the prostatic stent 10 to its original or first width by rotating the rotatable element 42 in a second direction while restraining the stationary element 54 from moving. Once the prostatic stent 10 is returned to its original width, the prostatic and bulbar segments 18, 20 now with the restored, larger diameters on either
20 side of the external sphincter 68, anchor the prostatic stent 10 within the proper position within the patient's urinary system as shown in FIG. 5B. The medical professional is then able to detach the rotatable element 42 from the prostatic segment 18 and the stationary element 54 from the bulbar segment 20 of the prostatic stent 10. With the connection arm 46 no longer attached to the prostatic stent 10, the connection arm 46 is able to pivot about hinge 50, thereby allowing

the medical professional to remove the rotatable element 42 and the connection arm 46 from the prostatic stent 10 without dislodging the positioning of the prostatic stent 10 after placement.

The detached rotatable element 42 and stationary element 54 are then removed from the patient's urinary system.

- 5 [0053] Refer to FIG. 6A for a more detailed depiction of the male urinary system. The urethra extends upward from the meatus urinanus 62 as far as the neck 64 of the bladder 66. Above the external sphinder 68, the urethra comprises a super-collicular prostatic segment 70 and a sub-collicular prostatic segment 72 of the prostate 74. Below the external sphincter 68, the urethra comprises, toward the meatus urinarius 62, the membranous segments 76, the bulbar
- 10 segment 78, the perineal segment 80, and the penile segment 82. The medical professional uses the delivery system 40 to advance the proximal tip 24 of the prostatic stent 10 along the urethra 60, past the external sphincter 68, and into the bladder 66. The medical professional inserts the prostatic stent 10 connected with the delivery system 40 into the patient's urethra at the meatus urinarius 62. The medical professional then further advances the prostatic stent 10 such that the
- 15 prostatic segment 18 is in the super-collicular prostatic section 70 of the urethra 60 surrounded by the prostate 74 with the bulbar segment 20 located on the distal side of the patient's external sphincter 68 along the bulbar segment 78 of the urethra 60. The prostatic stent 10 is properly positioned in the detailed depiction of the male urinary system as shown in FIG. 6B. At this
- 20 point, the delivery system 40 extends from the bladder 66 through the urethra 60 and terminates at a location external to the patient's body. In another embodiment, (where the delivery system 40 includes a lumen extending through the rotatable element 42 from the first end 44 of the rotatable element to the second end 48), the medical professional looks for urine flowing from the second end of the rotatable element 48 of the delivery system 40 located external to the patient's body to confirm correct placement of the prostatic stent 10.

[0054] The positioned prostatic stent 10 maintains the patency of the patient's prostatic urethra, while simultaneously allowing the patient to control the opening and closing of the external sphincter 68. The positioned prostatic stent 10 has no parts or elements that communicate external to the patient's body during use, thereby reducing the high risk of infection associated with catheters. The radial strength provided by the coil segment 12 prevents the patient's prostatic urethra from collapsing due to the pressure created by the patient's enlarged prostate 68. The prostatic stent 10 is anchored in position by the prostatic and bulbar segments 18, 20 that inhibit migration of the prostatic stent 10.

[0055] Referring to FIGS. 7A-7C the prostatic stent may be removed as follows. As all of the segments 18, 20, 22 and windings 15 of the prostatic stent 10 are formed from the single coil segment 12, the prostatic stent 10 may be removed by applying a tensile force along the removal segment 34, thereby unwinding the coil segment 12 and removing the prostatic stent 10. At the end of a prescribed time period, the patient can remove the prostatic stent 10 by pulling on the distal portion of the removal segment 36 extending back from the proximal tip 24, threaded through the prostatic and bulbar segments 18, 20 and extending through the penile segment 82 and through the meatus urinarius 62. When the outer coating 14 of the coil segment 12 is substantially absorbed, the structural integrity of the prostatic stent 10 is sufficiently attenuated to permit removal of the prostatic stent 10 transurethrally by the patient. As the distal portion of the removal segment 36 is continuously pulled, the proximal tip 24 of the prostatic segment 18 first unwinds and the remainder of the stent 10 progressively unwinds until uncoiling and removal of the prostatic stent 10 is achieved. As this invention is designed for indwelling within a lumen for a prescribed time period of minimal duration, incorporation of the stent within the urethra due to tissue ingrowth is not a concern.

[0056] Variations, modifications, and other implementations of what is described herein will occur to those of ordinary skill in the art without departing from the spirit and the scope of the invention. Accordingly, the invention is not to be limited to only the preceding illustrative description.

5 [0057] What is claimed is

Claims

- 1 1. A medical device for use within a body lumen of a patient, the device comprising:
2 a first coil having a plurality of windings defining a first lumen and locatable on the
3 proximal side of the external sphincter, the first coil having a distal end terminating on the
4 proximal side of the external sphincter when the device is placed within the body of the patient;
5 a second coil having a plurality of windings defining a second lumen and locatable on the
6 distal side of the external sphincter, the second coil having a proximal end terminating on the
7 distal side of the external sphincter when the device is placed within the body of the patient; and
8 a connecting segment locatable in the external sphincter when the device is placed within
9 the body of the patient, the connecting segment disposed between and coupling together the first
10 and second coils.
- 1 2. The medical device of claim 1 further comprising a removal segment attached to a
2 proximal end of the first coil.
- 1 3. The medical device of claim 2 wherein the removal segment is disposed within at least
2 one of the first lumen and the second lumen.
- 1 4. The medical device of claim 3 wherein at least one of the first coil, the second coil, and
2 the connecting segment further comprise an inner core and an outer coating covering at least a
3 portion of the inner core.
- 1 5. The medical device of claim 4 wherein the inner core comprises a biocompatible
2 material.
- 1 6. The medical device of claim 5 wherein the outer coating loses structural integrity during
2 hydration.

- 1 7. The medical device of claim 6 wherein the outer coating is absorbed into the lumen of a
2 patient at a predetermined degradation rate.
- 1 8. The medical device of claim 7 wherein the outer coating is selected from the group
2 consisting of polyglycolic acid, polylactic acid, or a polymer.
- 1 9. The medical device of claim 4 wherein the outer coating is a polyimide.
- 1 10. The medical device of claim 8 wherein the outer coating further comprises a
2 pharmaceutical.
- 1 11. The medical device of claim 4 wherein the windings of the first coil and the second coil
2 are sized and configured to progressively uncoil from the proximal end of the first coil to a distal
3 end of the second coil upon application of a continuous tensile force to the removal segment.
- 1 12. The medical device of claim 4 wherein the proximal end of the first coil comprises a
2 frusto-conical shape.
- 1 13. The medical device of claim 4 wherein the windings of the first coil and the second coil
2 are separated from each other by a distance in the range of from about 0.5 millimeters to about
3 10 millimeters.
- 1 14. The medical device of claim 4 wherein a cross-sectional area of the outer coating is in the
2 range of from about 7.9×10^{-3} millimeters² to about 7.1 millimeters².
- 1 15. The medical device of claim 4 wherein the proximal end of the first coil and the distal
2 end of the second coil include one or more hooks to permit connection to a delivery system.
- 1 16. A medical device for use within a body lumen of a patient, the device comprising:
2 an inner core including a first coil defining a first lumen and having a proximal
3 end and a distal end, a second coil defining a second lumen and having a proximal end
4 and a distal end, and a connecting segment therebetween, the inner core comprising a

5 plurality of spaced coil windings being sized and configured for placement and retention
6 substantially within the urethra of a patient; and

7 an outer coating layered upon at least a portion of the inner core for supporting
8 the first lumen and the second lumen of the inner core when placed with the body lumen
9 of the patient.

1 17. The medical device of claim 16 wherein the first coil, second coil and connecting
2 segment are of unitary construction.

1 18. The medical device of claim 16 further comprising a removal segment attached to the
2 proximal end of the first coil.

1 19. The medical device of claim 18 wherein the removal segment is disposed within at least
2 one of the first lumen and the second lumen.

1 20. The medical device of claim 17 wherein the outer coating loses structural integrity during
2 hydration.

1 21. The medical device of claim 16 wherein the inner core comprises a biocompatible
2 material.

1 22. The medical device of claim 20 wherein the outer coating is absorbed into the lumen of a
2 patient at a predetermined degradation rate.

1 23. The medical device of claim 22 wherein the outer coating is selected from the group
2 consisting of polyglycolic acid, polylactic acid, or a polymer.

1 24. The medical device of claim 16 wherein the outer coating is a polyimid material.

1 25. The medical device of claim 16 wherein the outer coating further comprises a
2 pharmaceutical.

- 1 26. The medical device of claim 16 wherein the windings are sized and configured to
2 progressively uncoil from the proximal end of the first coil to the distal end of the second coil
3 upon application of a continuous tensile force to the removal segment.
- 1 27. The medical device of claim 16 wherein the proximal end of the first coil further
2 comprises a frusto-conical shape.
- 1 28. The medical device of claim 16 wherein windings of the first coil and the second coil are
2 separated by a distance in the range of from about 0.5 millimeters to about 10 millimeters.
- 1 29. The medical device of claim 16 wherein a cross-sectional area of the outer coating is in
2 the range of from about 7.9×10^{-3} millimeters² to about 7.1 millimeters².
- 1 30. The medical device of claim 16 wherein the proximal end of the first coil and the distal
2 end of the second coil includes one or more hooks to permit connection to a delivery system.
- 1 31. A method of maintaining the patency of a patient's urethra, the method comprising the
2 steps of:
- 3 a. supporting the prostatic section of a the urethra with a first coil defining a first
4 lumen and locatable on the proximal side of the external sphincter;
- 5 b. supporting the bulbar section of a the urethra with a second coil defining a second
6 lumen and locatable on the distal side of the external sphincter; and
- 7 c. permitting substantially normal constriction of the external sphincter with a
8 substantially uncoiled connecting segment disposed between and coupling the first coil and
9 second coil.
- 1 32. The method of claim 31 further comprising the steps of:
- 2 a. providing a system comprising (1) a first element having an outer diameter
3 smaller than the diameters of the first coil and the second coil and including a first end, a second
4 end, and a connection member extending out from the first end and (2) a second element

- 5 including a first end, a second end, and a connection member extending out from the first end, at
6 least one of the first and second elements of the delivery system being rotatable;
- 7 b. placing the first element of the delivery system within the lumen of the first and
8 second segments;
- 9 c. attaching the connection member of the first element to the proximal portion of
10 the first segment;
- 11 d. attaching the connection member of the second element to the distal end of the
12 second segment;
- 13 e. rotating at least one of the first and the second elements to further wind the one or
14 more windings to reduce the width of the stent at least to an extent needed to pass the stent into
15 the urethra of the patient; and
- 16 f. removing the delivery system completely from the lumens of the first and second
17 segments and from the patient's urethra, thereby leaving the stent positioned within the patient's
18 urinary system.

1 33. The method of claim 32 wherein the connection member of the first element comprises
2 an arm extending radially outward from the first end and includes an opening sized to receive a
3 hook extending from the proximal portion.

1 34. The method of claim 32 wherein the connection member of the second element
2 comprises an arm extending radially outward from the first end and includes an opening sized to
3 receive the hooks extending from the proximal portion of the first segment and the distal end of
4 the second segment.

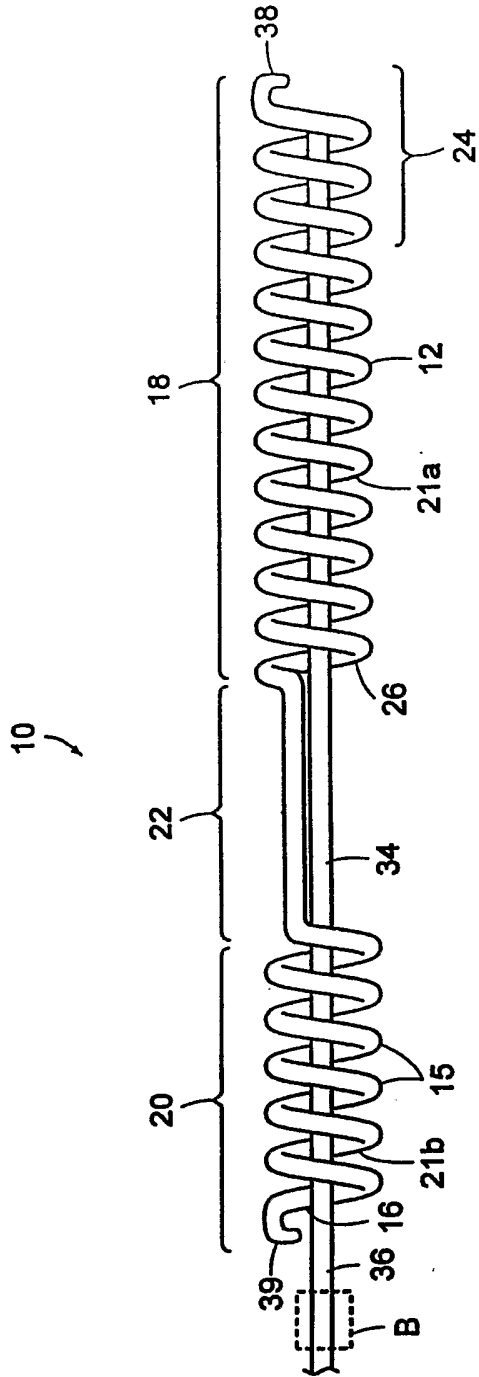

FIG. 1A

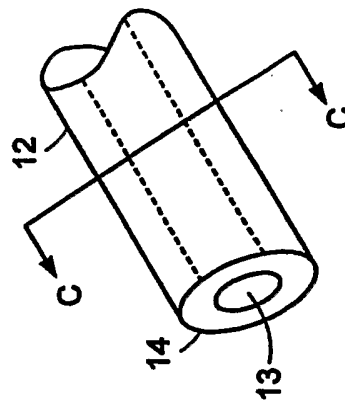

FIG. 1B

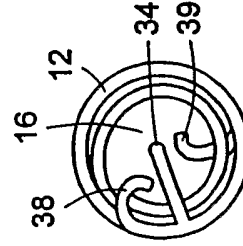

FIG. 1C

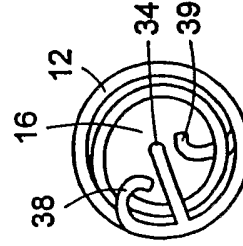

FIG. 1D

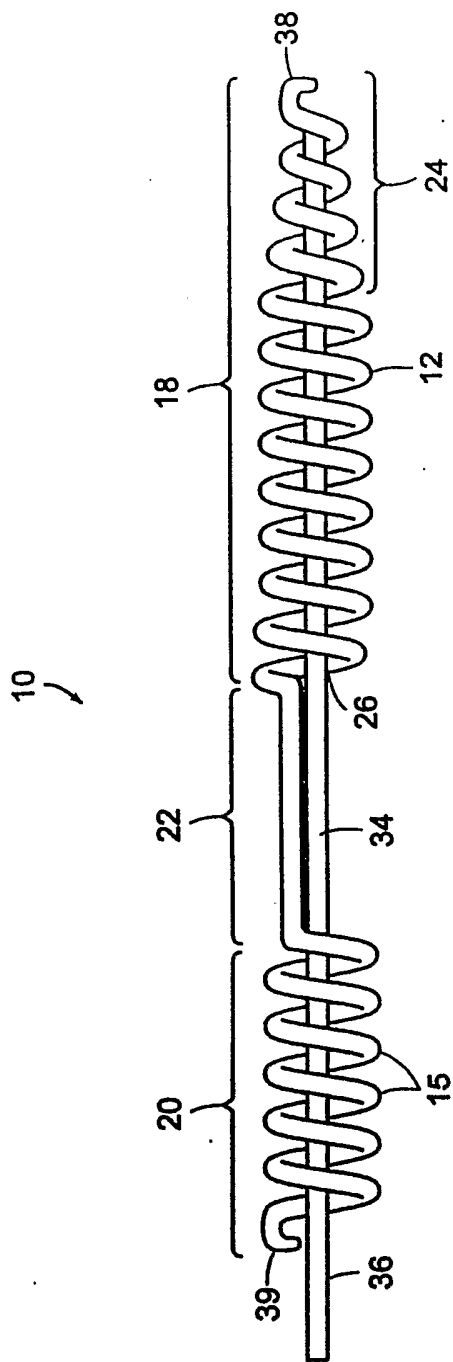

FIG. 2

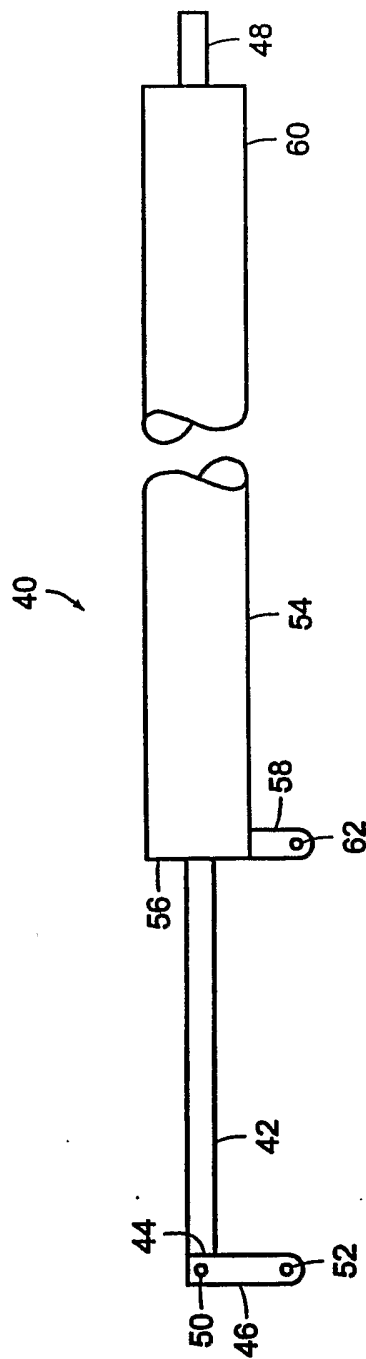
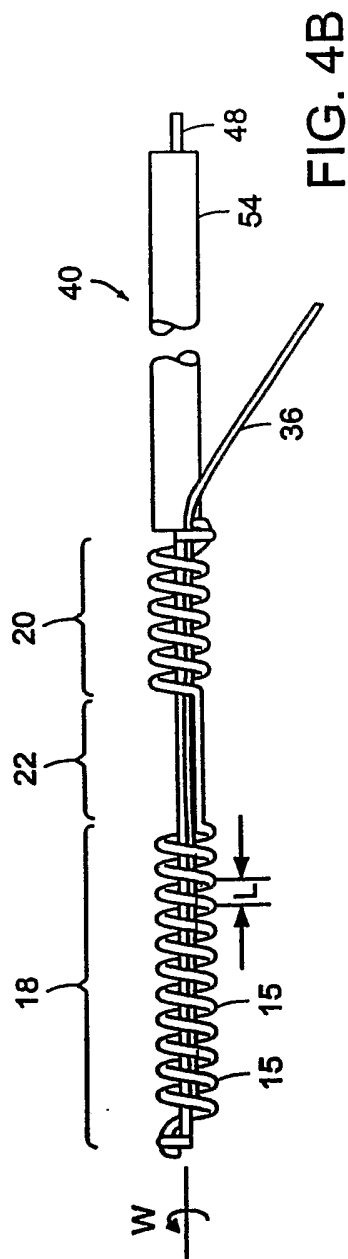
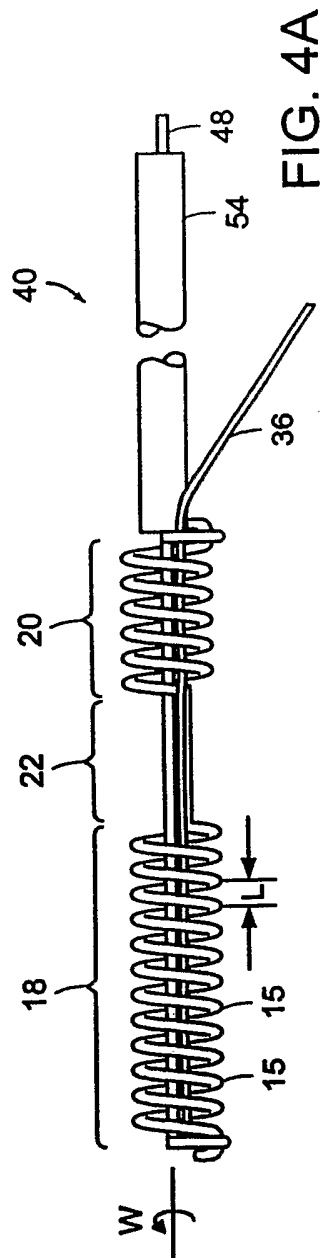

FIG. 3



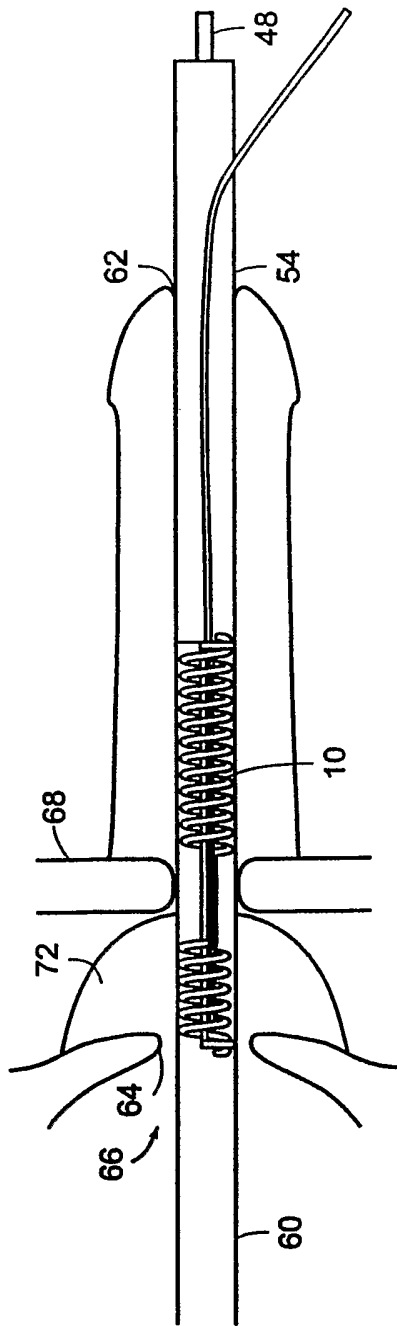

FIG. 5A

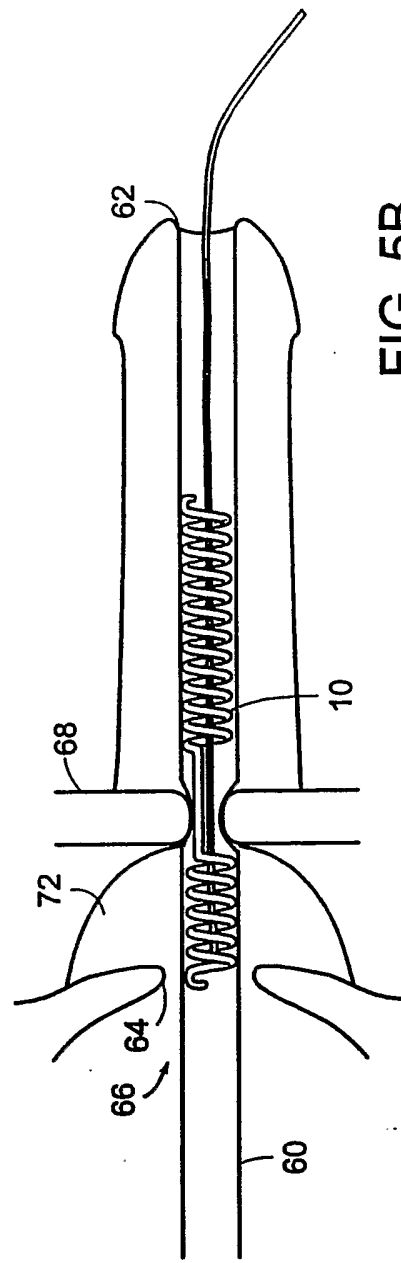

FIG. 5B

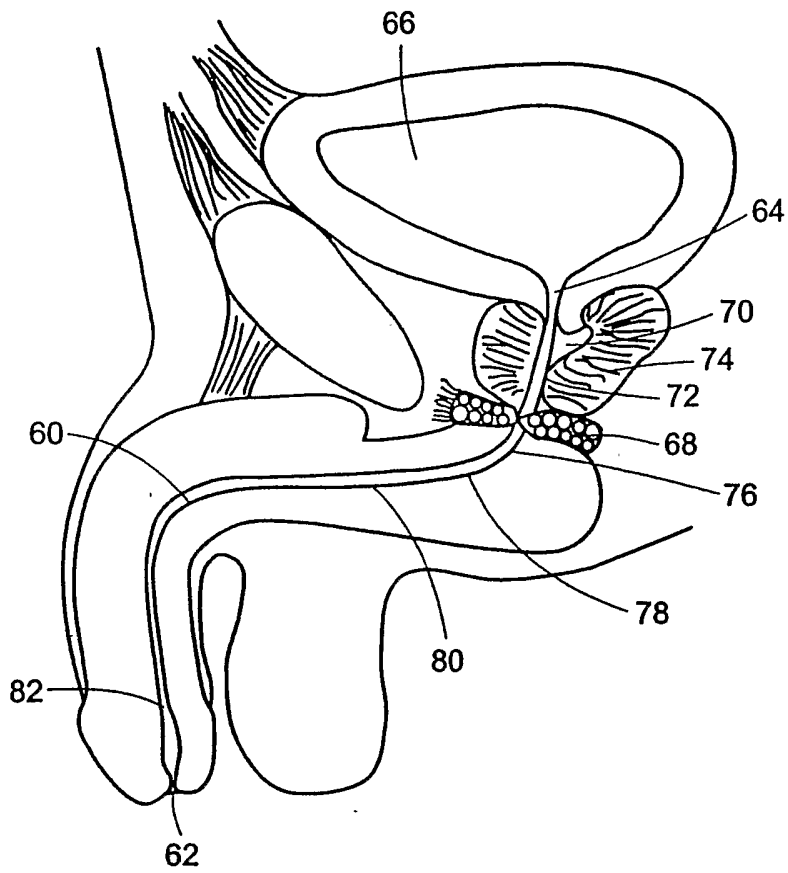

FIG. 6A

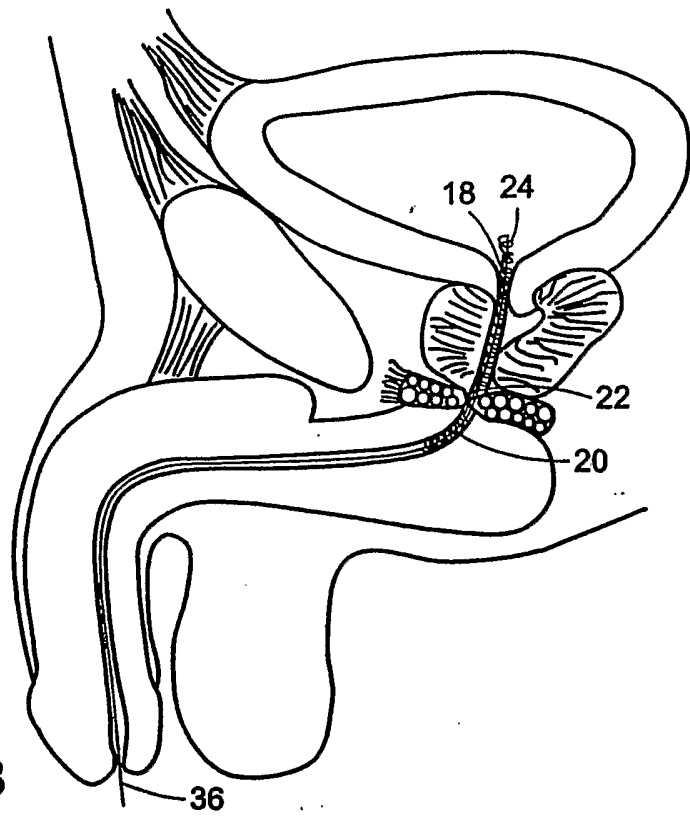

FIG. 6B

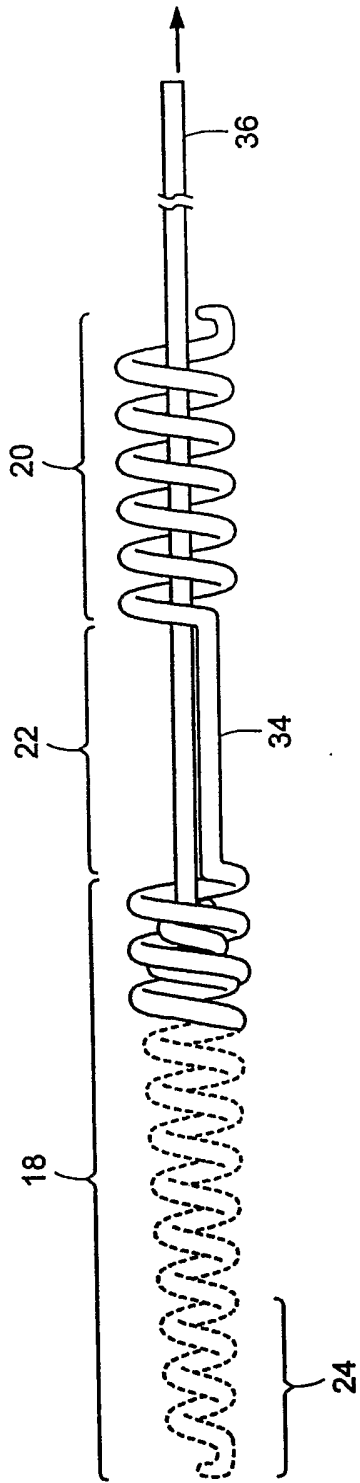

FIG. 7A

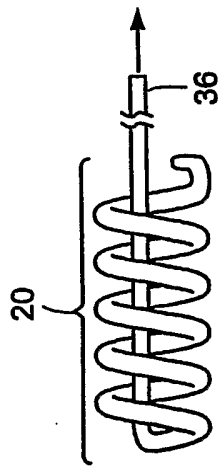

FIG. 7B

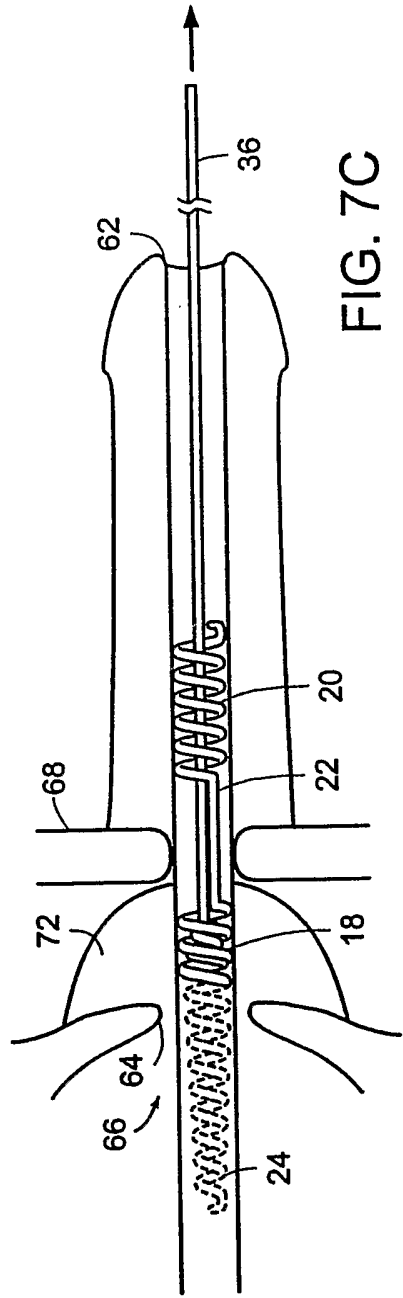

FIG. 7C

INTERNATIONAL SEARCH REPORT

International Application No
PCT/US 03/32286

A. CLASSIFICATION OF SUBJECT MATTER
IPC 7 A61F2/04

According to International Patent Classification (IPC) or to both national classification and IPC

B. FIELDS SEARCHED

Minimum documentation searched (classification system followed by classification symbols)
IPC 7 A61F

Documentation searched other than minimum documentation to the extent that such documents are included in the fields searched

Electronic data base consulted during the international search (name of data base and, where practical, search terms used)

EPO-Internal

C. DOCUMENTS CONSIDERED TO BE RELEVANT

Category °	Citation of document, with indication, where appropriate, of the relevant passages	Relevant to claim No.
X	US 5 514 178 A (TORCHIO GERARD) 7 May 1996 (1996-05-07) column 3, line 10 -column 5, line 18	1
Y	----	2-30
Y	WO 00 45744 A (SCIMED LIFE SYSTEMS INC ;WANG LIXIAO (US); STANSLASKI JOEL (US); Y) 10 August 2000 (2000-08-10) page 8, line 18 -page 10, line 5	2-30
X	FR 2 661 603 A (CORALINES ABJ DIVISION SARL) 8 November 1991 (1991-11-08) page 5, line 19 -page 9, line 28	1
A	----	2-30
X	US 5 540 701 A (SHARKEY HUGH R ET AL) 30 July 1996 (1996-07-30) column 6, line 23 - line 50	1
A	-----	2-30

Further documents are listed in the continuation of box C.

Patent family members are listed in annex.

° Special categories of cited documents :

- "A" document defining the general state of the art which is not considered to be of particular relevance
- "E" earlier document but published on or after the international filing date
- "L" document which may throw doubts on priority claim(s) or which is cited to establish the publication date of another citation or other special reason (as specified)
- "O" document referring to an oral disclosure, use, exhibition or other means
- "P" document published prior to the international filing date but later than the priority date claimed

- "T" later document published after the international filing date or priority date and not in conflict with the application but cited to understand the principle or theory underlying the invention
- "X" document of particular relevance; the claimed invention cannot be considered novel or cannot be considered to involve an inventive step when the document is taken alone
- "Y" document of particular relevance; the claimed invention cannot be considered to involve an inventive step when the document is combined with one or more other such documents, such combination being obvious to a person skilled in the art.
- "&" document member of the same patent family

Date of the actual completion of the international search

27 January 2004

Date of mailing of the international search report

04/02/2004

Name and mailing address of the ISA
European Patent Office, P.B. 5818 Patentlaan 2
NL - 2280 HV Rijswijk
Tel. (+31-70) 340-2040, Tx. 31 651 epo nl,
Fax: (+31-70) 340-3016

Authorized officer

Mary, C

INTERNATIONAL SEARCH REPORT

International application No.
PCT/US 03/32286

Box I Observations where certain claims were found unsearchable (Continuation of item 1 of first sheet)

This International Search Report has not been established in respect of certain claims under Article 17(2)(a) for the following reasons:

1. Claims Nos.: 31-34
because they relate to subject matter not required to be searched by this Authority, namely:
Rule 39.1(iv) PCT - Method for treatment of the human or animal body by surgery
2. Claims Nos.:
because they relate to parts of the International Application that do not comply with the prescribed requirements to such an extent that no meaningful International Search can be carried out, specifically:
3. Claims Nos.:
because they are dependent claims and are not drafted in accordance with the second and third sentences of Rule 6.4(a).

Box II Observations where unity of invention is lacking (Continuation of item 2 of first sheet)

This International Searching Authority found multiple inventions in this International application, as follows:

1. As all required additional search fees were timely paid by the applicant, this International Search Report covers all searchable claims.
2. As all searchable claims could be searched without effort justifying an additional fee, this Authority did not invite payment of any additional fee.
3. As only some of the required additional search fees were timely paid by the applicant, this International Search Report covers only those claims for which fees were paid, specifically claims Nos.:
4. No required additional search fees were timely paid by the applicant. Consequently, this International Search Report is restricted to the invention first mentioned in the claims; it is covered by claims Nos.:

Remark on Protest

- The additional search fees were accompanied by the applicant's protest.
- No protest accompanied the payment of additional search fees.

INTERNATIONAL SEARCH REPORT

Information on patent family members

International Application No

PCT/US 03/32286

Patent document cited in search report		Publication date	Patent family member(s)	Publication date
US 5514178	A	07-05-1996	FR 2706764 A1	30-12-1994
			AT 221347 T	15-08-2002
			DE 69431090 D1	05-09-2002
			DE 69431090 T2	27-03-2003
			EP 0631762 A1	04-01-1995
			ES 2177567 T3	16-12-2002
			JP 3321494 B2	03-09-2002
			JP 7136282 A	30-05-1995
			WO 0045744	A
AU 2724800 A	25-08-2000			
EP 1150622 A1	07-11-2001			
JP 2002536058 T	29-10-2002			
WO 0045744 A1	10-08-2000			
US 2002151844 A1	17-10-2002			
FR 2661603	A	08-11-1991	FR 2661603 A1	08-11-1991
US 5540701	A	30-07-1996	NONE	