

(No Model.)

2 Sheets—Sheet 1.

G. W. GROSS.

MACHINE FOR CUTTING LEATHER.

No. 346,651.

Patented Aug. 3, 1886.

Fig 1.

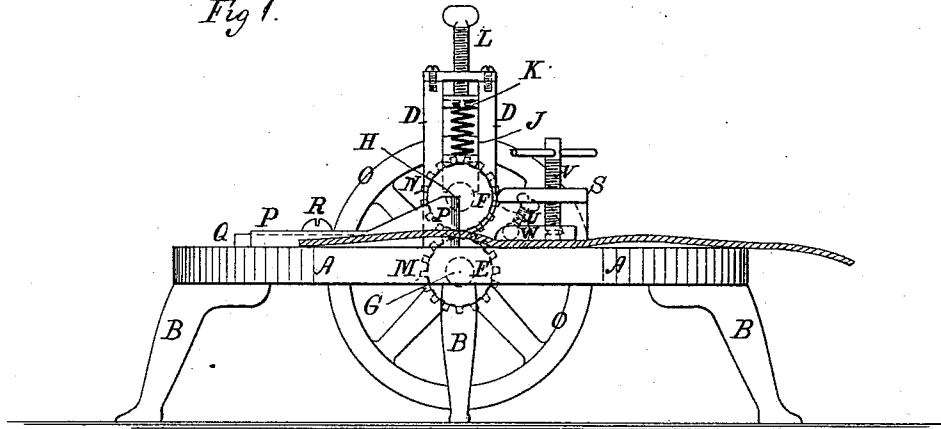
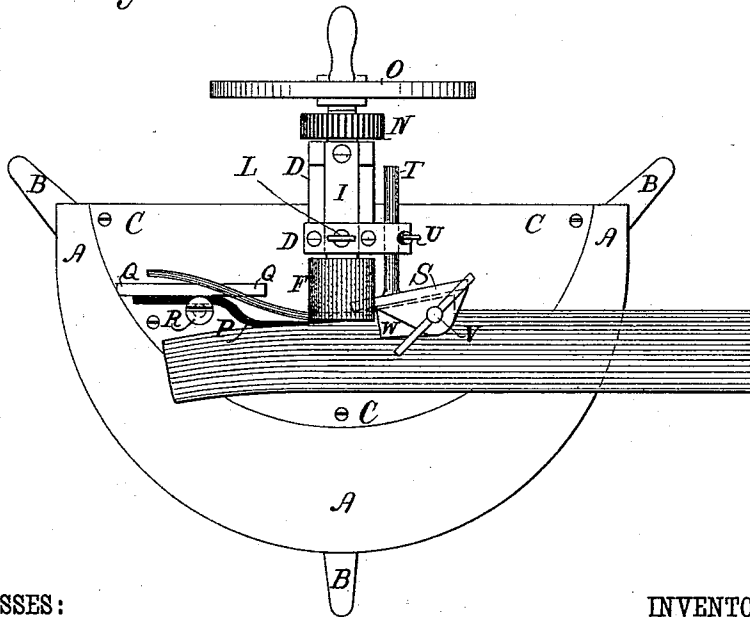

Fig 2



WITNESSES:

John Cook
& Sedgwick

INVENTOR:

G. W. Gross
 BY *Munn & Co*
 ATTORNEYS.

G. W. GROSS.

MACHINE FOR CUTTING LEATHER.

No. 346,651.

Patented Aug. 3, 1886.

Fig 3

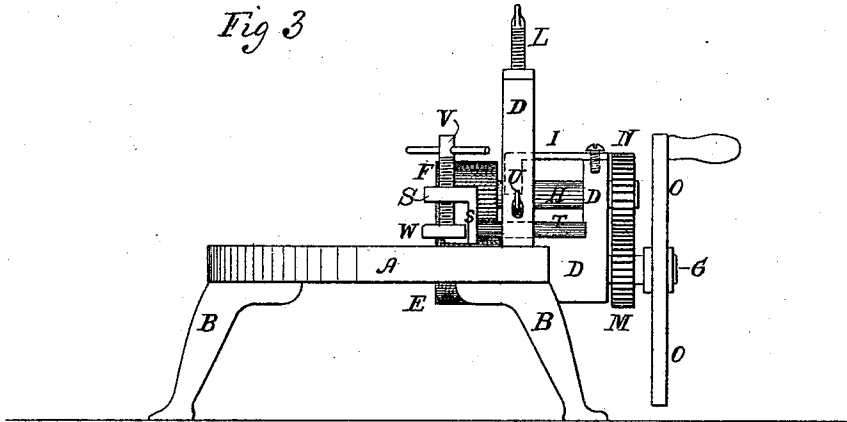
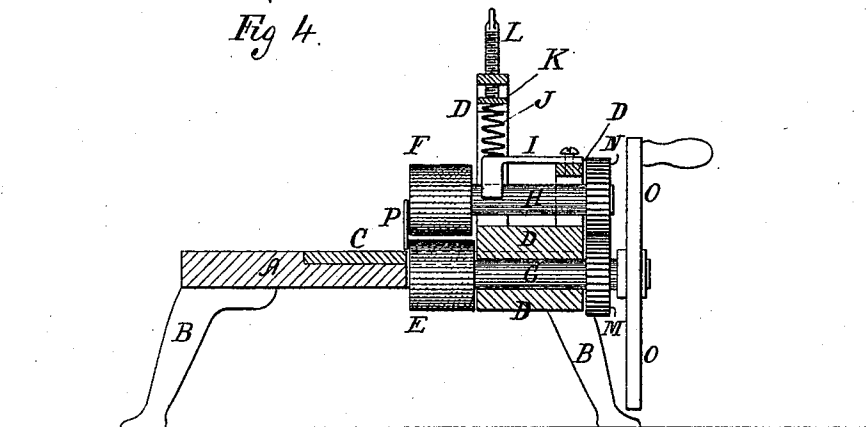

Fig 4



WITNESSES:

John Cook
C. Bedgwick

INVENTOR:

G. W. Gross

BY

Munn & Co

ATTORNEYS.

UNITED STATES PATENT OFFICE.

GEORGE WASHINGTON GROSS, OF OXFORD, NEW JERSEY.

MACHINE FOR CUTTING LEATHER.

SPECIFICATION forming part of Letters Patent No. 346,651, dated August 3, 1886.

Application filed September 28, 1885. Renewed May 28, 1886. Serial No. 203,564. (No model.)

To all whom it may concern:

Be it known that I, GEORGE WASHINGTON GROSS, of Oxford, in the county of Warren and State of New Jersey, have invented a new and useful Improvement in Machines for Cutting Leather, of which the following is a full, clear, and exact description.

Reference is to be had to the accompanying drawings, forming a part of this specification, in which similar letters of reference indicate corresponding parts in all the figures.

Figure 1, Sheet 1, is a side elevation of one of my improved machines for cutting leather. Fig. 2, Sheet 1, is a plan view of the same. Fig. 3, Sheet 2, is a front elevation of the same. Fig. 4, Sheet 2, is a sectional front elevation of the same.

The object of this invention is to facilitate the cutting of leather into strips and straps of various widths, and promote convenience in adjusting machines for cutting leather.

The invention consists in the construction and arrangement of parts, as will be hereinafter fully described and claimed.

A represents the table of the machine, which may be made of any desired or convenient shape or size, and is mounted upon legs B, of such a length as to raise the machine to a convenient height.

C is a metallic plate, which is let into the upper side of the table A so that its upper surface will be flush with the upper surface of the said table A.

The table A and plate C are slotted to receive the frame D, which is secured to the said table and plate by bolts or other suitable means.

E F are two feed-rollers placed one directly above the other, and which are attached to or formed upon the inner ends of two shafts, G H. The lower shaft, G, revolves in bearings in the body of the frame D, and the upper shaft, H, revolves in slots in the standards of the said frame. The outer standard of the frame D is made short, and to its cap is attached the outer end of the bar I, the inner end of which enters the slot of the longer inner standard of the said frame D, and has a half-bearing formed upon its lower side to rest upon the upper shaft, H.

Upon the upper side of the inner end of the

bearing-bar I rests the lower end of a spiral or other suitable spring, J, upon the upper end of which rests a plate, K. To the plate K is swiveled, or upon it rests, the end of the hand-screw L, which passes down through a screw-hole in the cap of the inner standard of the frame D, so that the upper feed-roller, F, can be held down with any desired force by adjusting the hand-screw L.

To the outer end of the shafts G H are attached gear-wheels M N, the teeth of which mesh into each other, and to the end of the lower shaft, G, is attached a crank-wheel or pulley, O, according as the machine is to be driven by hand or other power. The crank-wheel O is made heavy, so that it will serve as a fly-wheel to give steadiness of motion to the feed-rollers E F. The leather is cut by the knife P, the side of the edge of which rests against the end of the feed-rollers E F at their adjacent sides. The shank of the knife P rests against the side of a rib, Q, formed upon the upper side of the plate C, and is held in place by a screw, R, screwed into the plate C, as shown in Fig. 2.

S is a right-angled plate placed with its horizontal arm upward. To the vertical arm of the plate S is attached, or upon it is formed, a rod or stem, T, which passes through a lug or projection formed upon the side of the lower part of the inner standard of the frame D, where it is held in place by a hand-screw, U, passing in through the said lug or projection and resting against the said stem. By loosening the hand-screw U the gage-plate S can be adjusted to cause the machine to cut a strip or strap of any desired width.

Through a screw-hole in the horizontal arm of the angular gage-plate S passes a hand-screw, V, the lower end of which is swiveled to a plate, W, to rest upon the part of the leather that bears against the gage-plate S, and passes between the feed-rollers E F, to hold the said part of the leather smooth, and thus insure an accurate cutting of the said leather. By adjusting the hand-screw V the plate W can be readily adjusted to the thickness of the leather to be cut.

In using the machine the gage-plate S is adjusted to give a strip of the desired width, and the plate W is adjusted to the thickness of

the leather. The leather is then slipped forward to bring its edge between the feed-rollers E F, and the crank-wheel or pulley O is turned, causing the said feed-rollers to carry the leather forward against the edge of the knife P, the said knife being so adjusted as to cut the leather opposite the point that is held between the said rollers.

Having thus fully described my invention, I claim as new and desire to secure by Letters Patent—

1. In a machine for cutting leather, the combination, with the feed-rolls, of a horizontally-adjustable gage-plate in front of the rolls and adapted to regulate the width of the material to be cut, and a vertically-movable plate secured to said gage and adapted to bear on the leather being cut, substantially as set forth.

2. In a machine for cutting leather, the combination, with the table A, provided with the bed-plate C and frame D, of the rollers and shafts E F G H, the driving gear-wheels M N and crank-wheel or pulley O, and the press-

ure-spring, plate, and hand-screw J K L, substantially as herein shown and described, whereby the leather will be fed to the knife and securely held while being cut, as set forth.

3. In a machine for cutting leather, the combination, with the bed-plate C, having rib Q, and the feed and holding rollers E F, of the knife P and screw R, substantially as herein shown and described, whereby the leather will be cut as it is fed forward and held by the said rollers, as set forth.

4. In a machine for cutting leather, the combination, with the frame D and the rollers E F, of the angular gage-plate S, having stem T and hand-screw U, and the guide-plate W and swiveled screw V, substantially as herein shown and described, whereby the leather is guided to the feed-rollers and the knife, as set forth.

GEORGE WASHINGTON GROSS.

Witnesses:

J. F. MATHEWS,
EDMUND GROSS.