

(12) **UK Patent Application** (19) **GB** (11) **2 316 293** (13) **A**

(43) Date of A Publication 25.02.1998

(21) Application No 9606839.0

(22) Date of Filing 30.03.1996

(71) Applicant(s)
Eric Cadenhead
24 Cleveden Gardens, GLASGOW, G12 0PT,
United Kingdom

(72) Inventor(s)
Eric Cadenhead

(74) Agent and/or Address for Service
Fitzpatricks
4 West Regent Street, GLASGOW, G2 1RS,
United Kingdom

(51) INT CL⁶
A42B 3/04

(52) UK CL (Edition P)
A3V V11D

(56) Documents Cited
GB 1468323 A **GB 1389980 A** **WO 93/22160 A1**
US 4891736 A **US 4559586 A**

(58) Field of Search
UK CL (Edition O) **A3V**
INT CL⁶ **A42B 3/04**
Online: **WPI**

(54) **Motor cyclist crash helmet with lighting unit**

(57) The helmet has warning lights carried by the shell 7 that comprise an elongate lighting unit formed by a row of light emitting diodes (LEDs) 14 that provide rear brake and indicating lights. The lighting unit which is provided with a lens 12 may also provide a constant rear light and extend around the helmet to provide a front light source. The helmet may comprise an external recess to receive the lighting unit or have an open slot so that the unit is removable via the internal side. Alternatively, the unit may be fitted onto a standard helmet. The warning lights can be synchronised with the lights of a motor bike via a flexible cable or a transmitter / receiver arrangement.

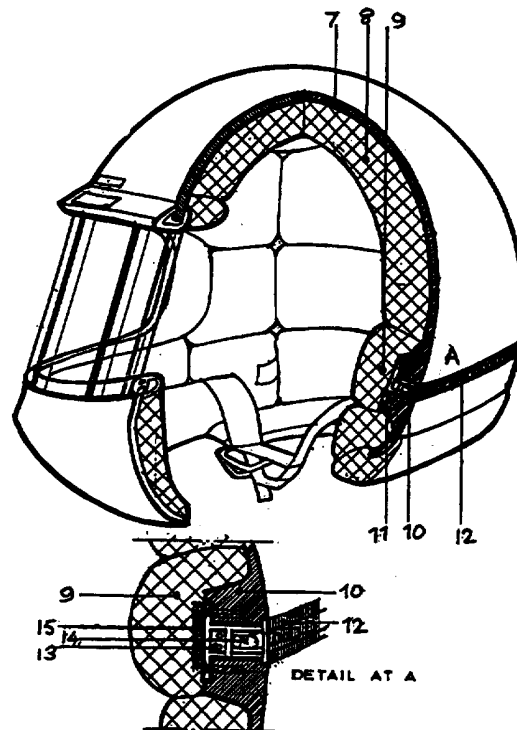

GB 2 316 293 A

At least one drawing originally filed was informal and the print reproduced here is taken from a later filed formal copy.

The claims were filed later than the filing date within the period prescribed by Rule 25(1) of the Patents Rules 1995

1/11

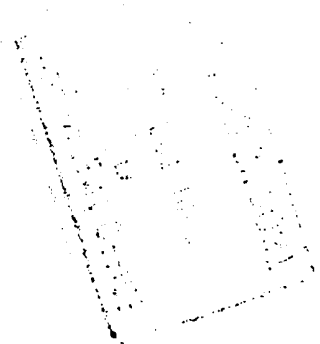
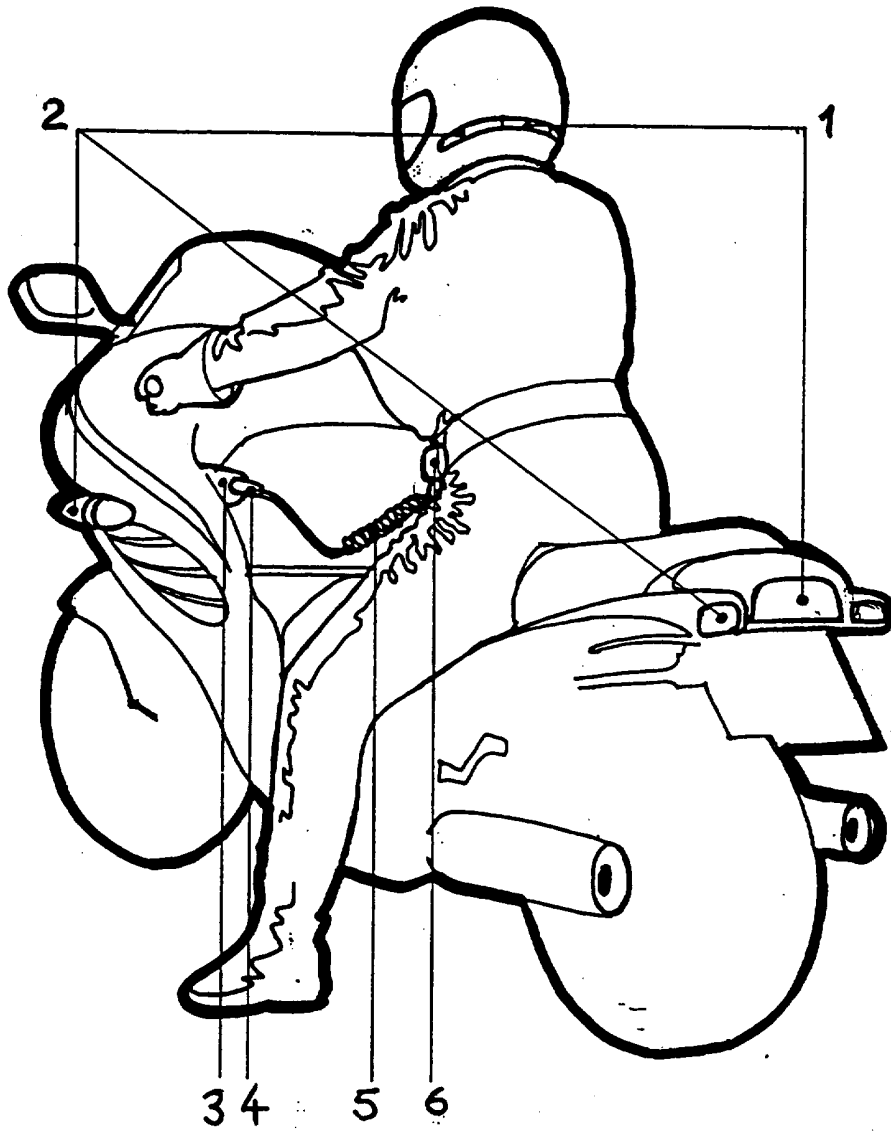

2/11

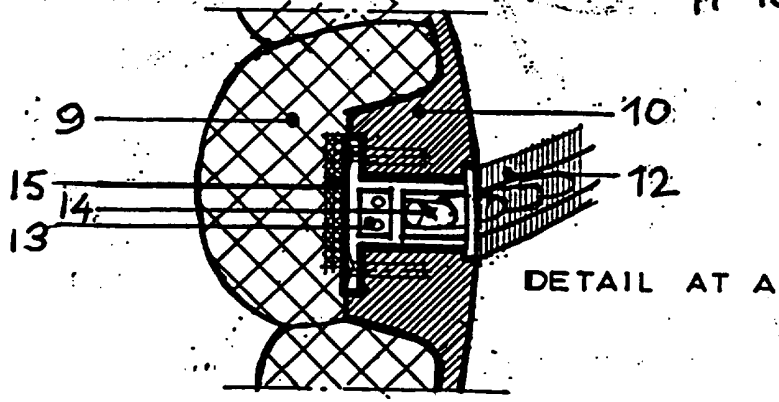
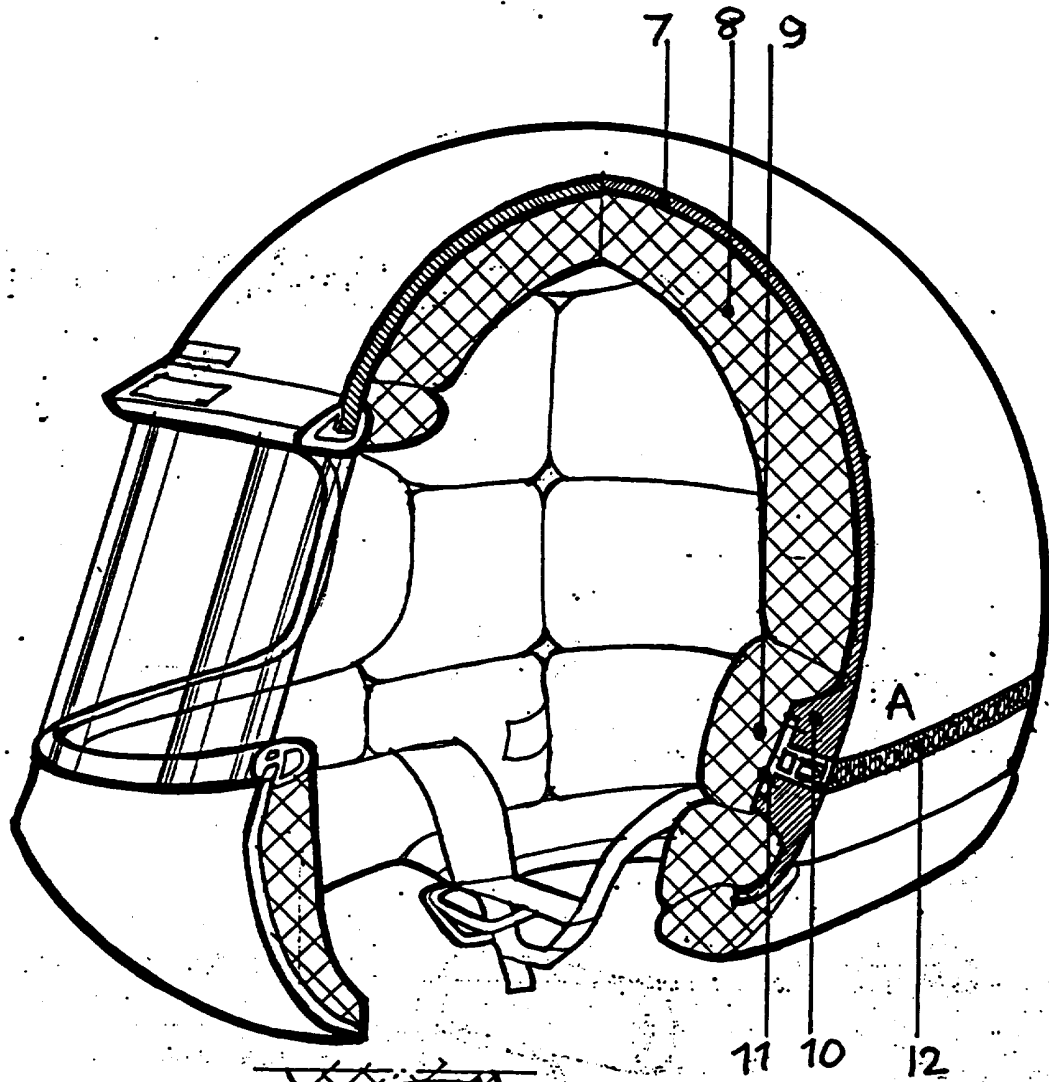

3/11

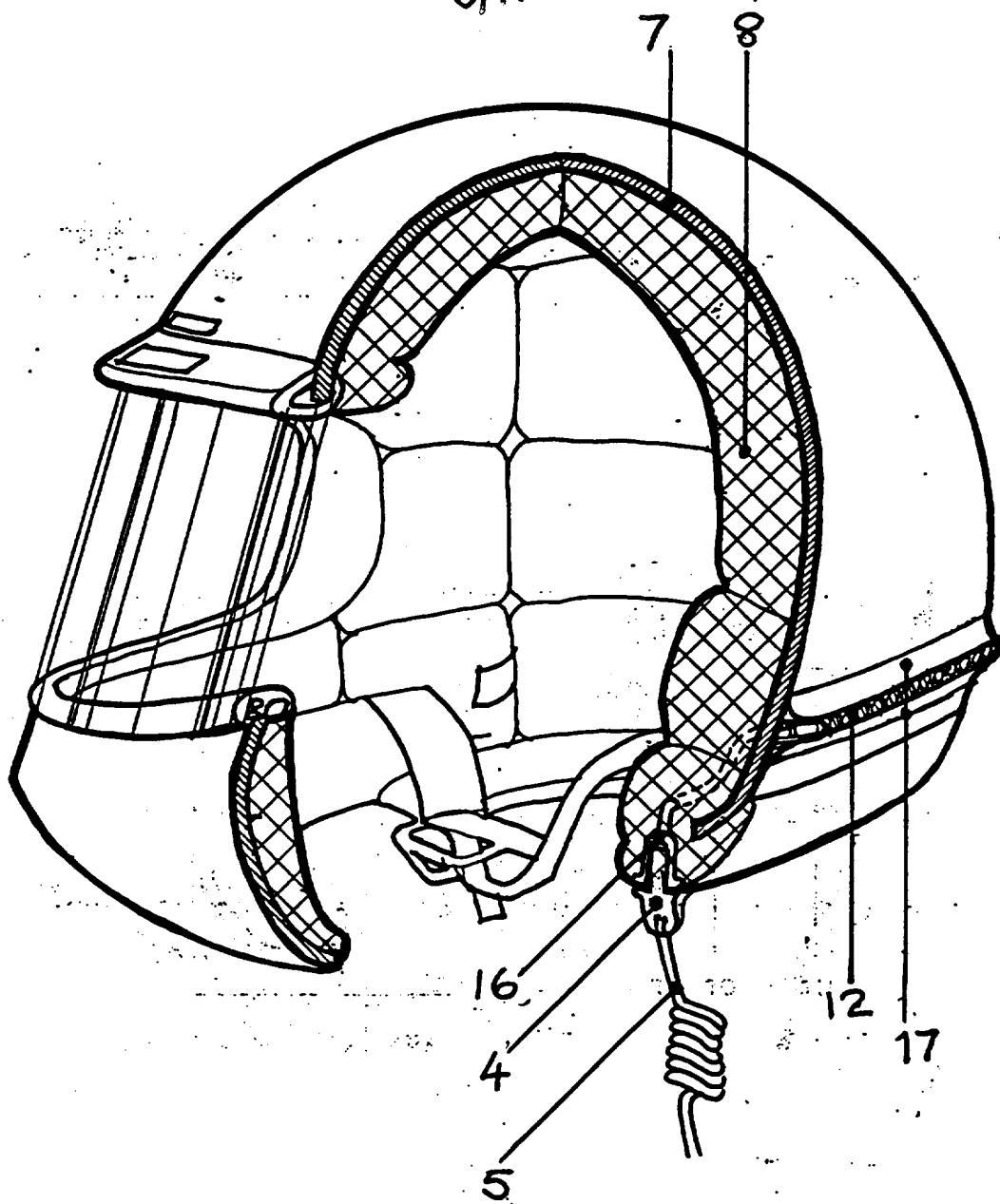

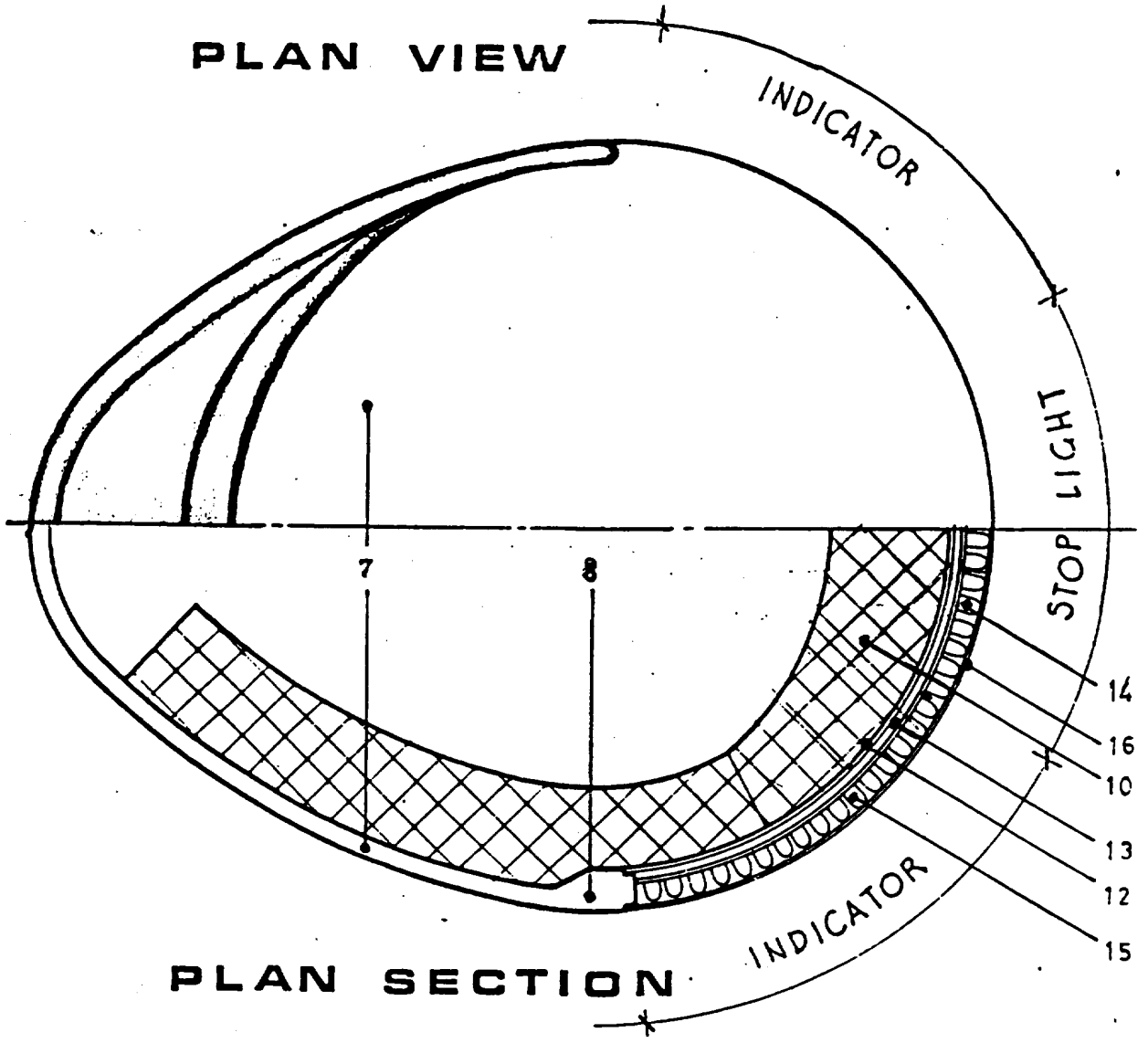

PLAN VIEW

INDICATOR

STOP LIGHT

7

8

14

16

10

13

12

15

PLAN SECTION

INDICATOR

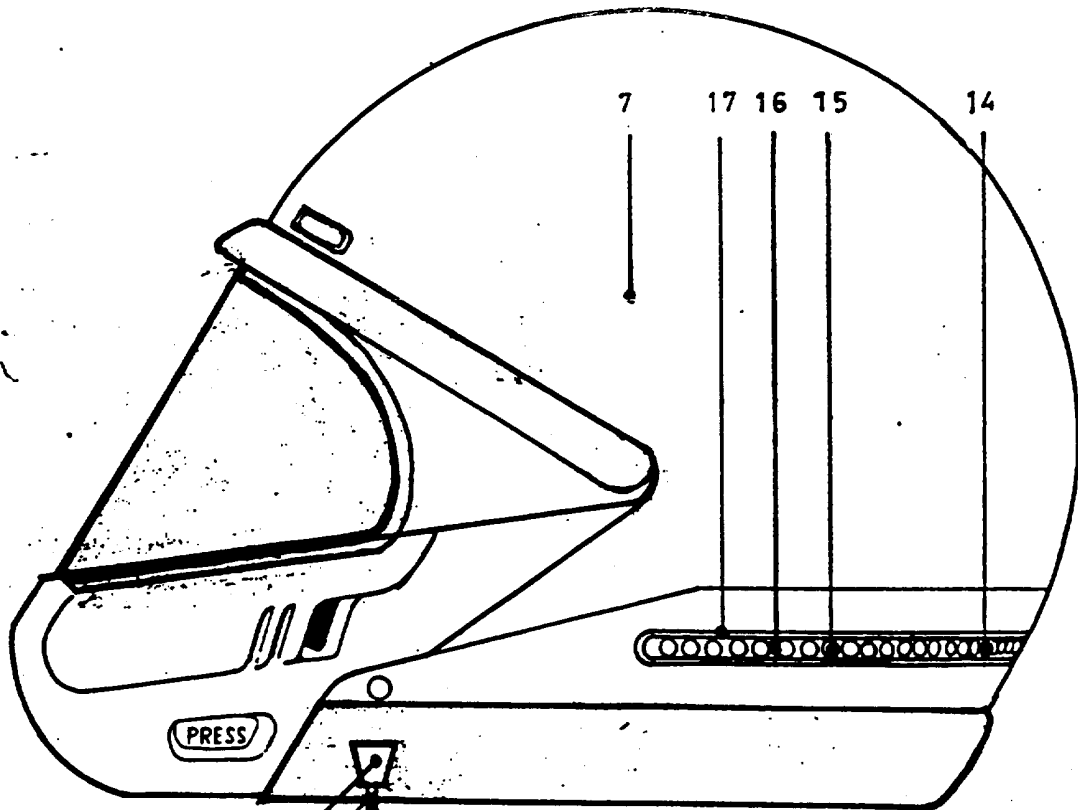

SIDE VIEW

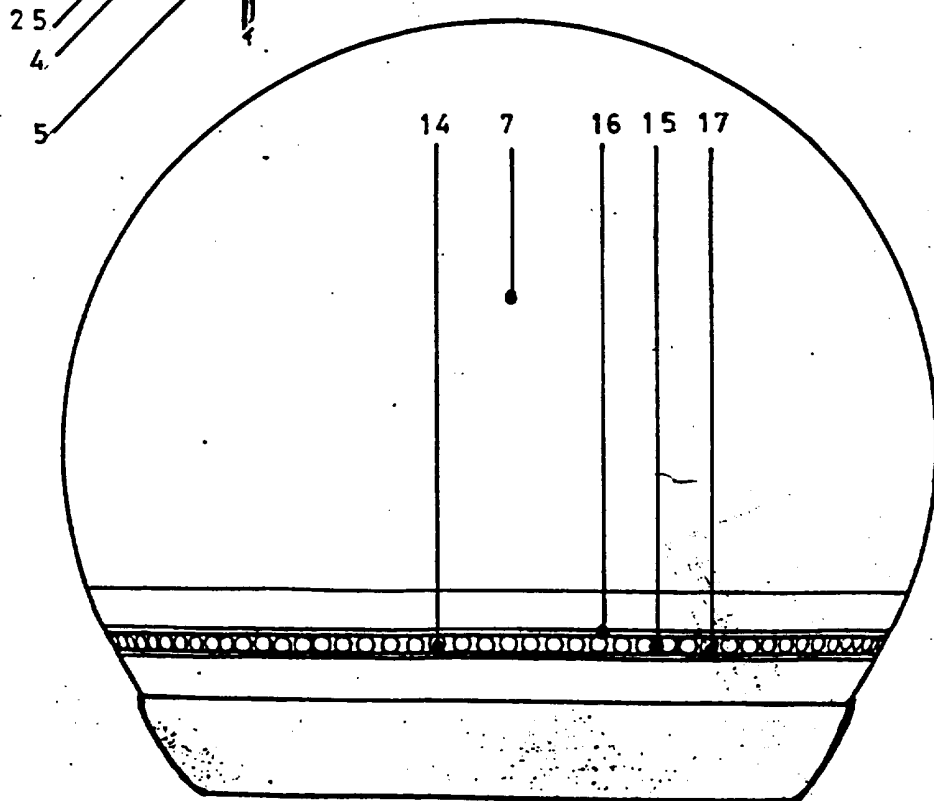

REAR VIEW

6/11

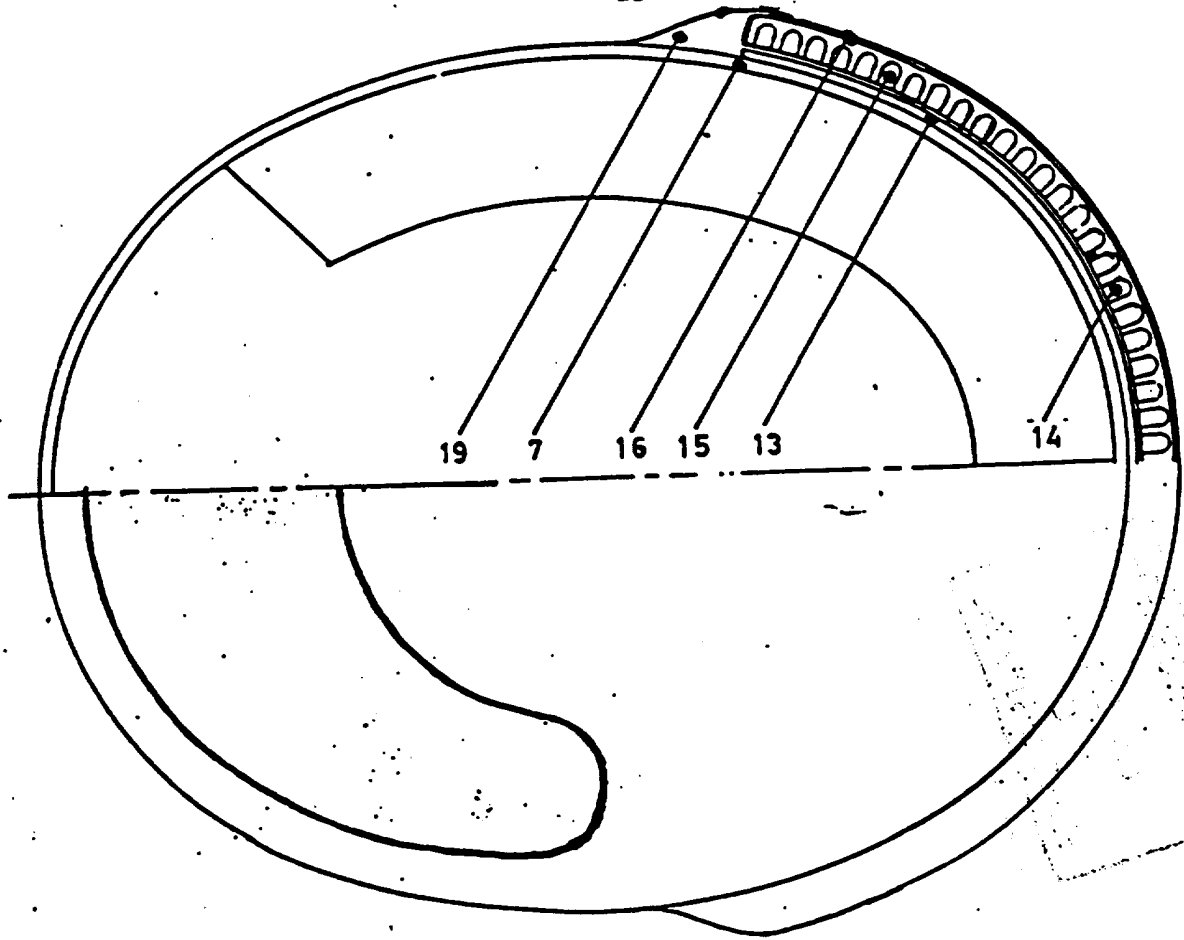
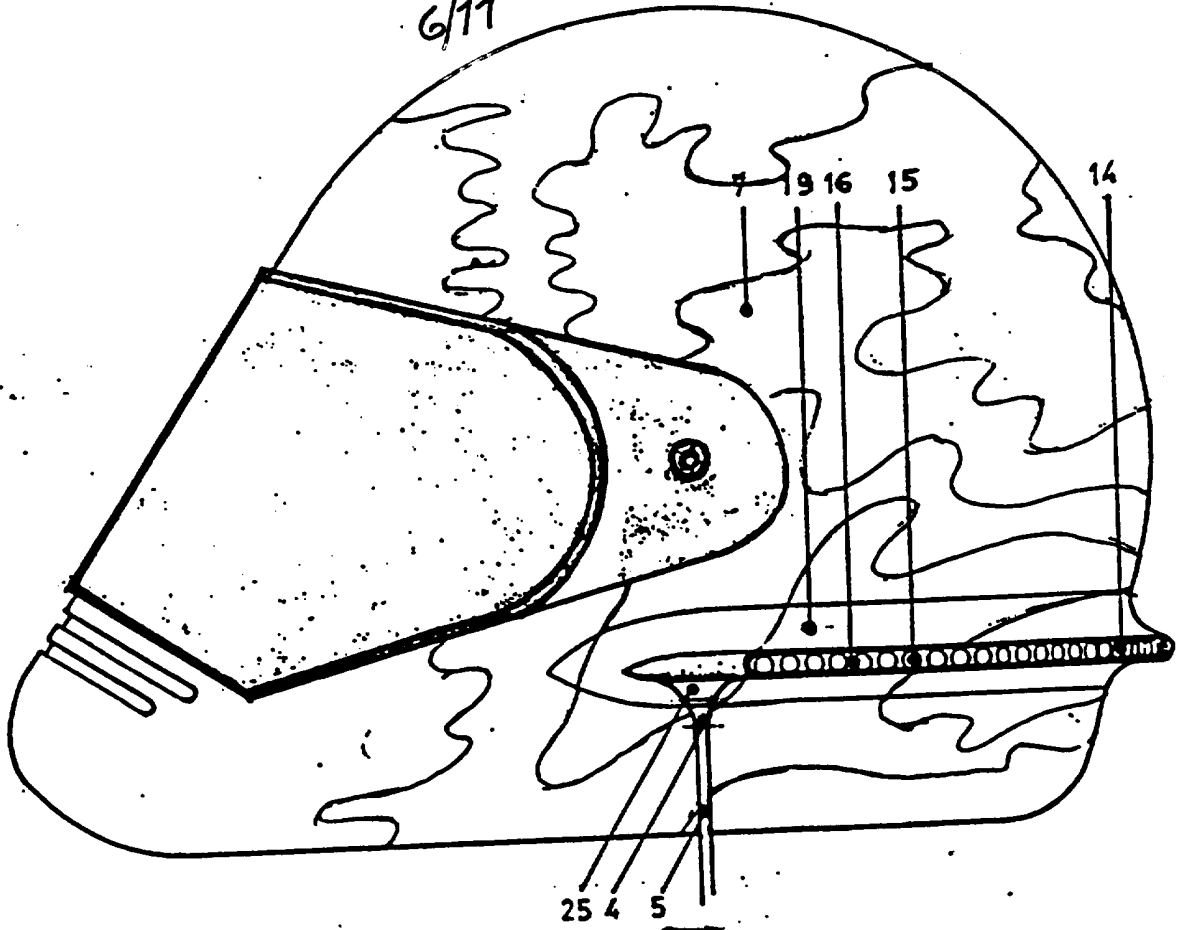

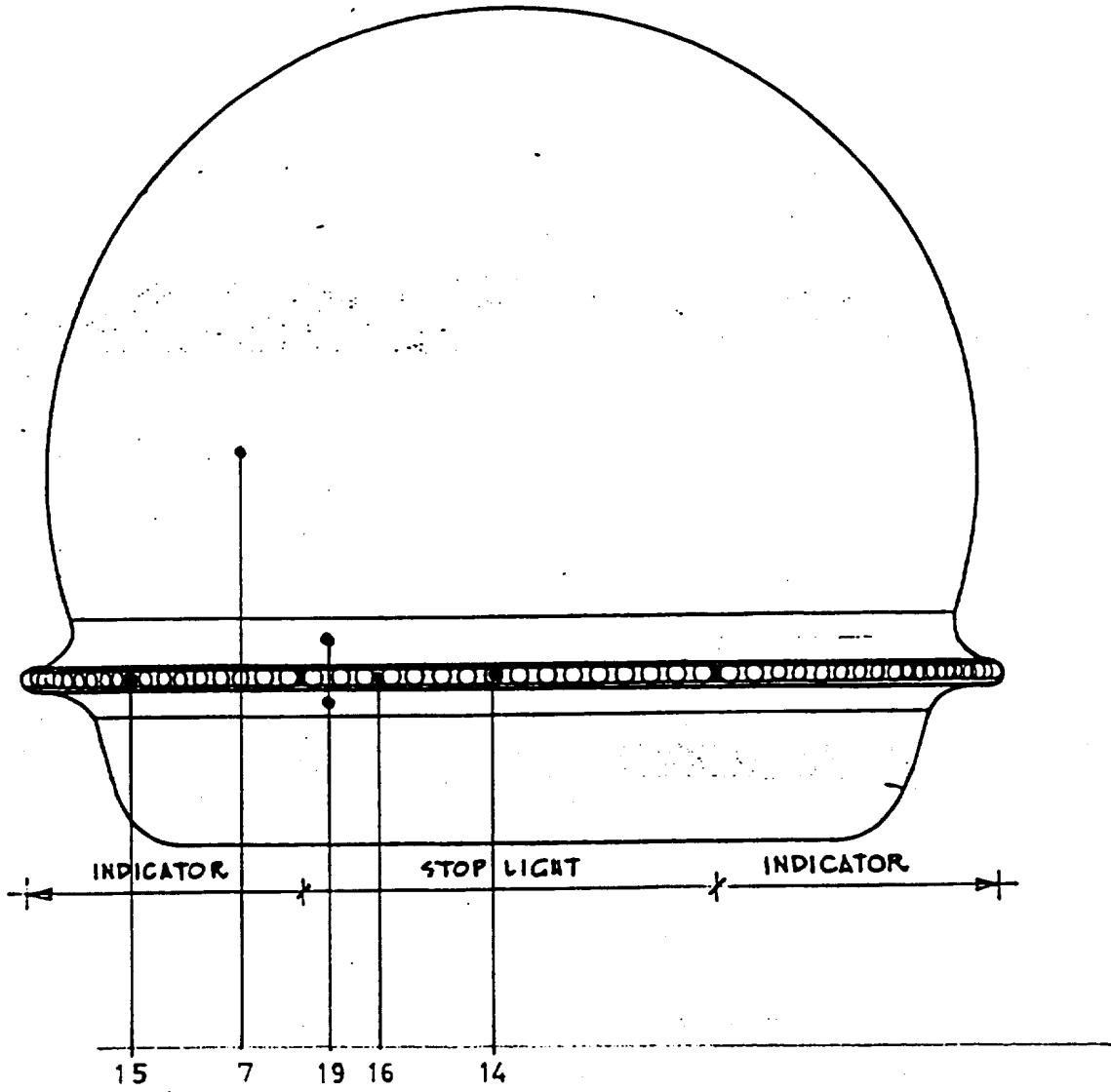

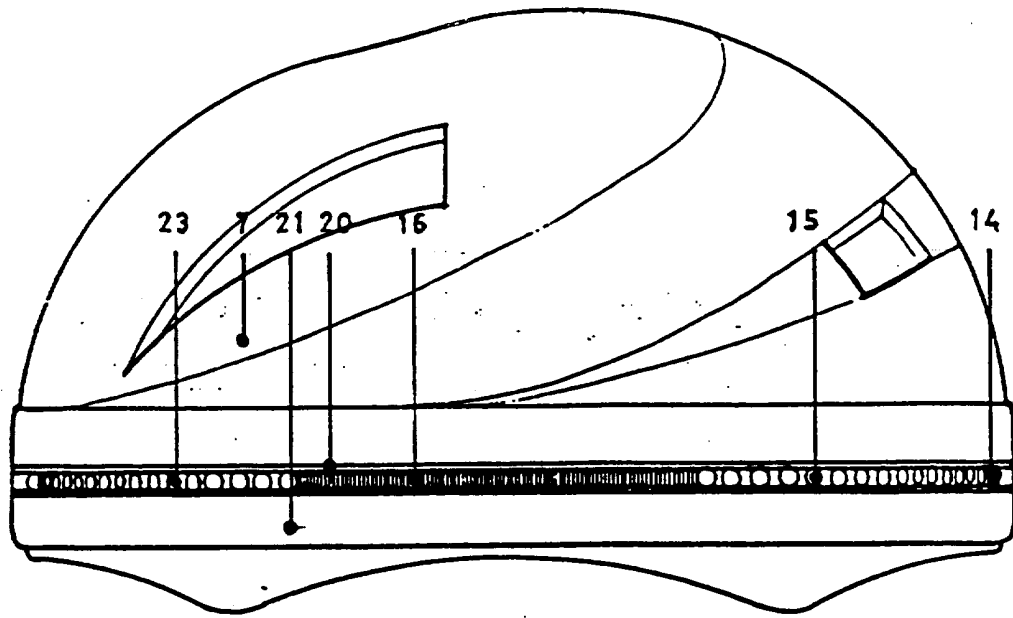

SIDE VIEW

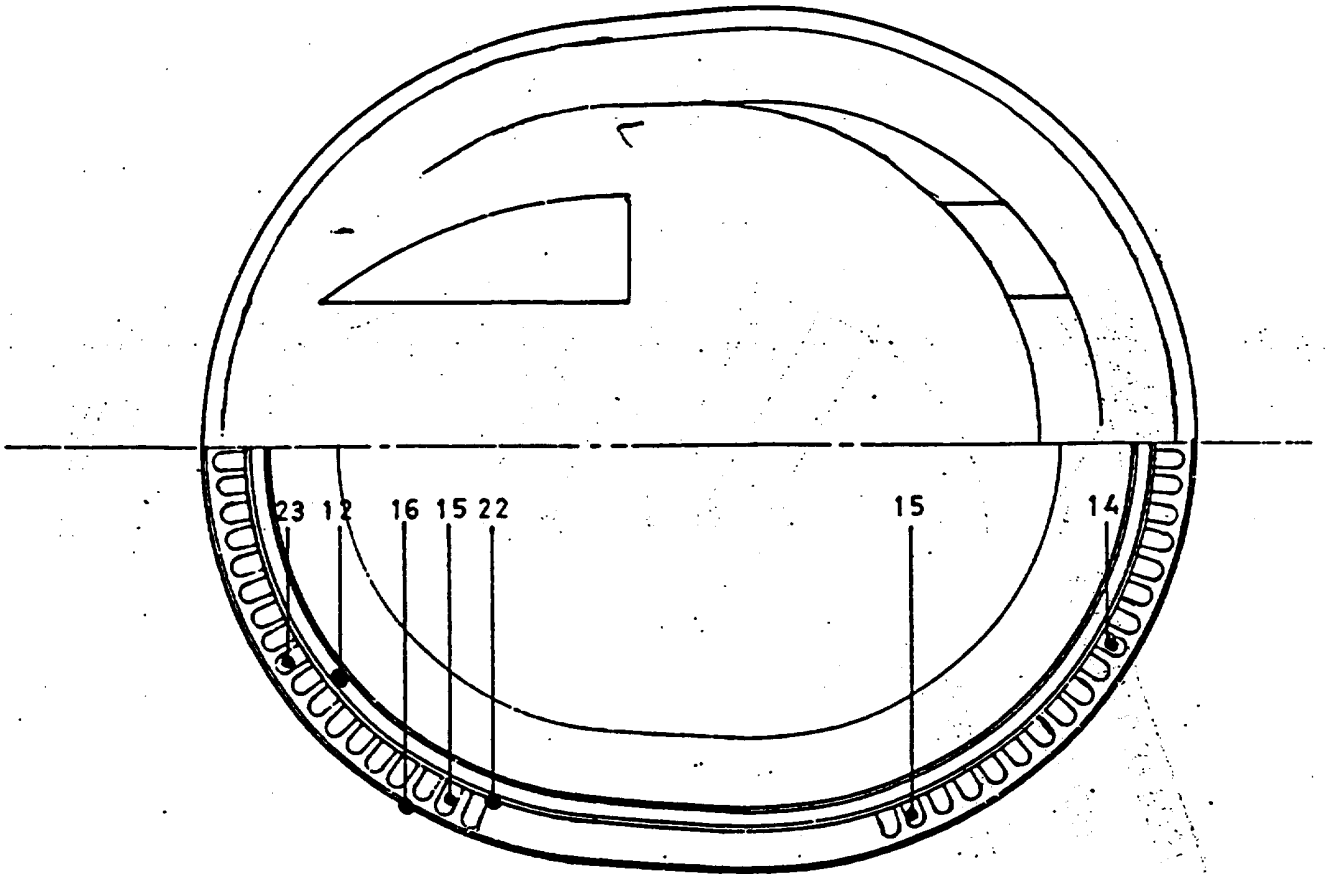

PLAN / SECTION

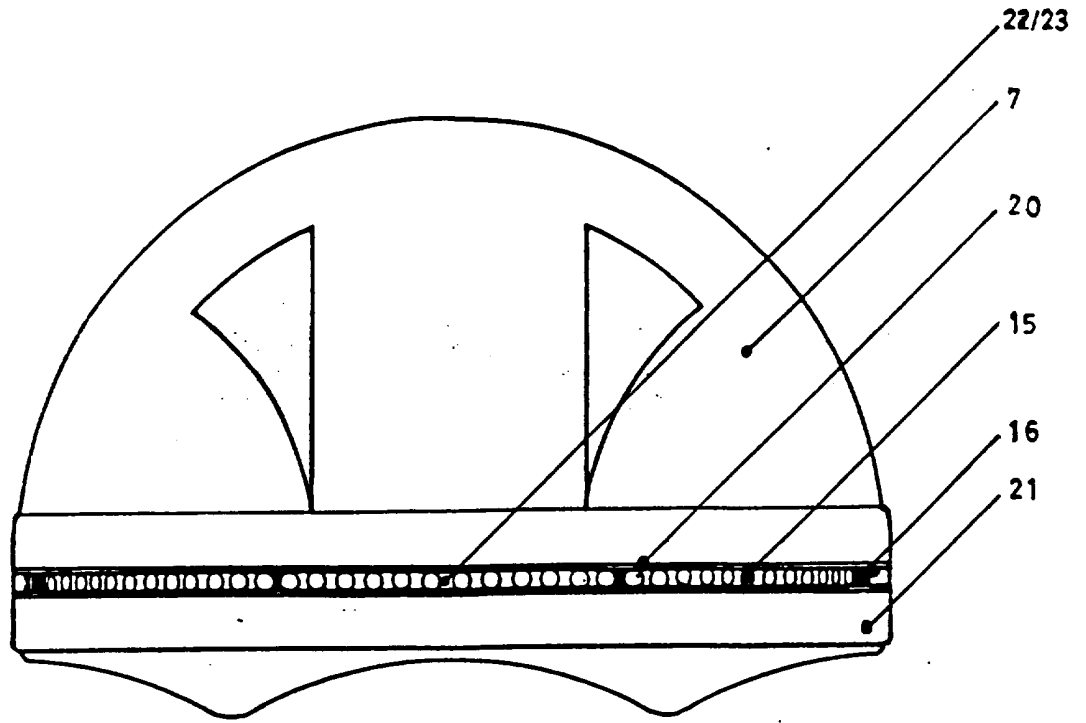

FRONT VIEW

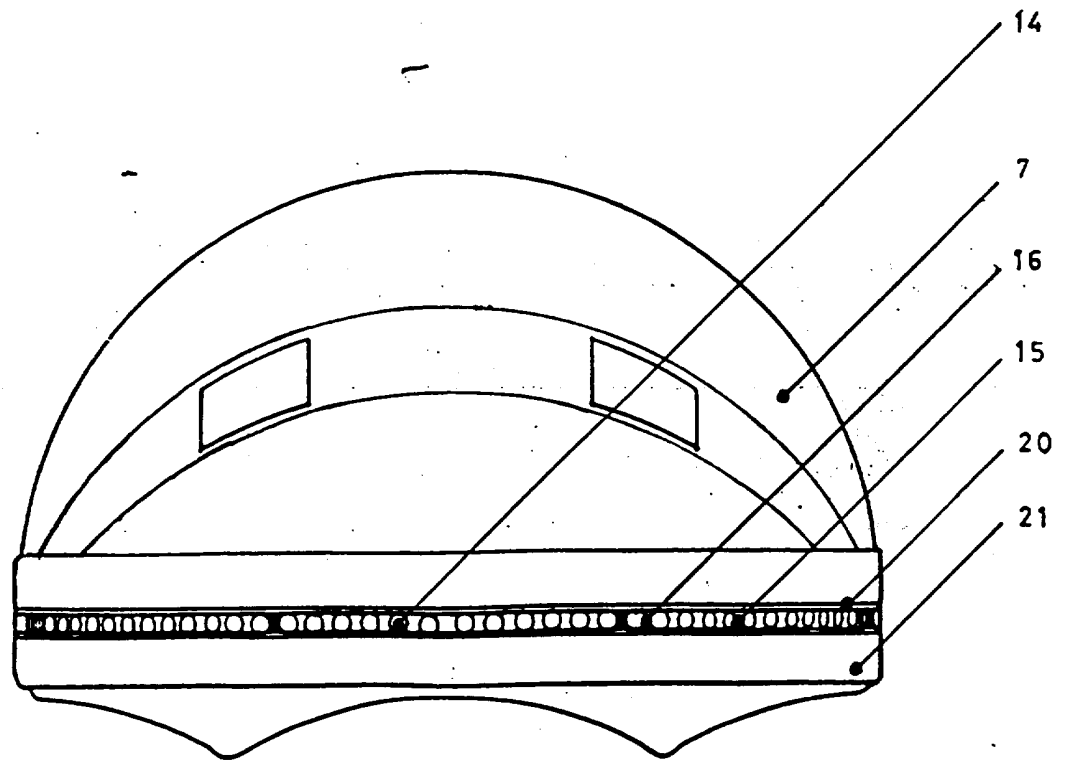

REAR VIEW

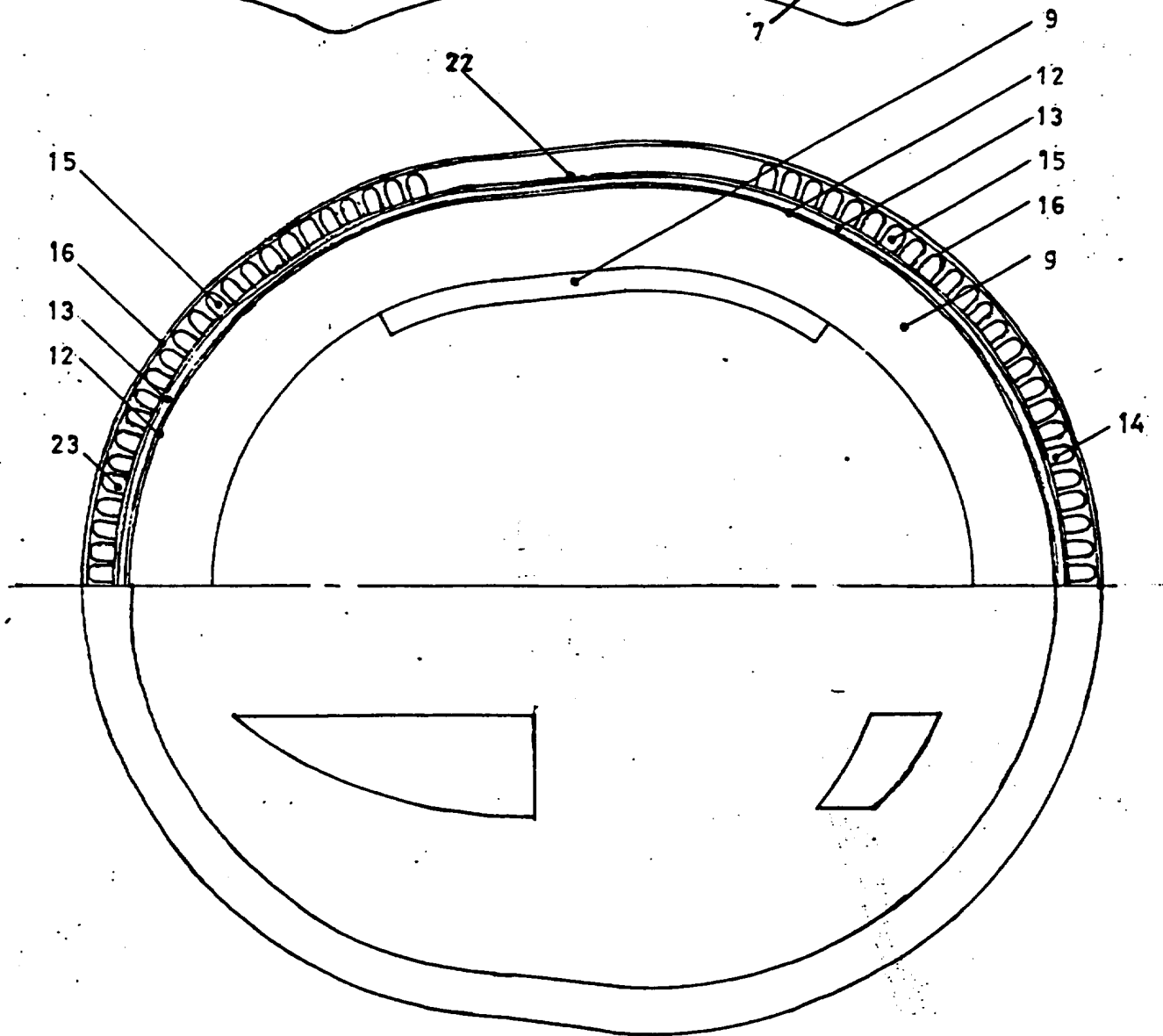
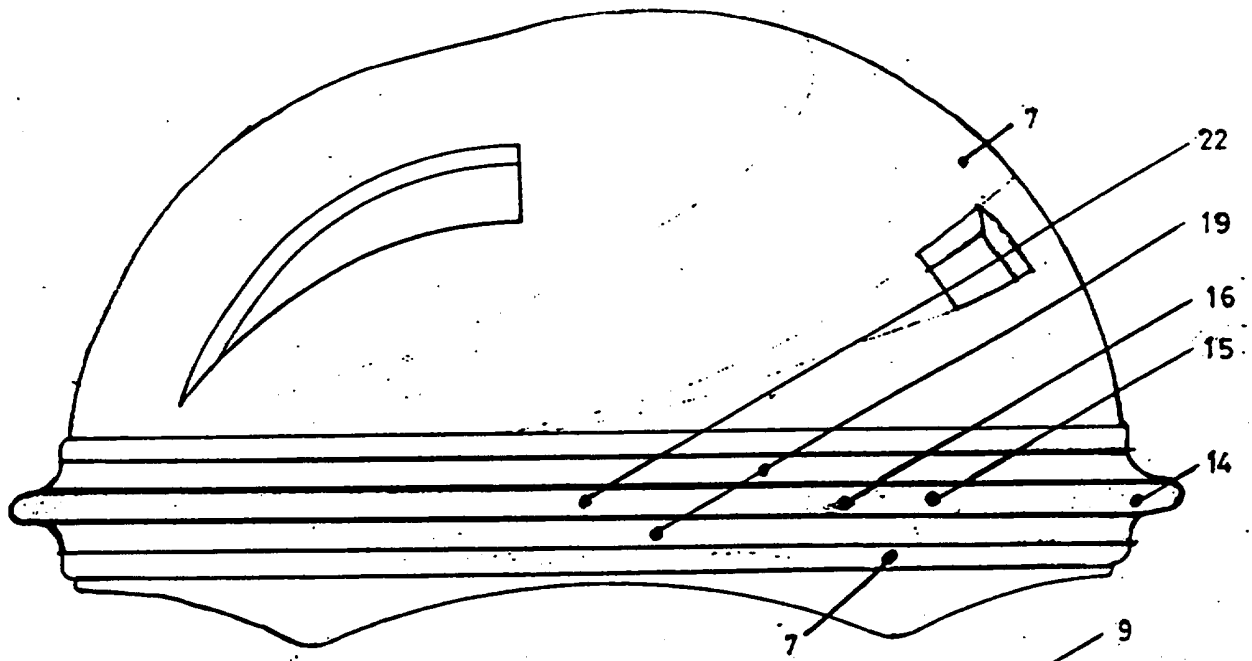

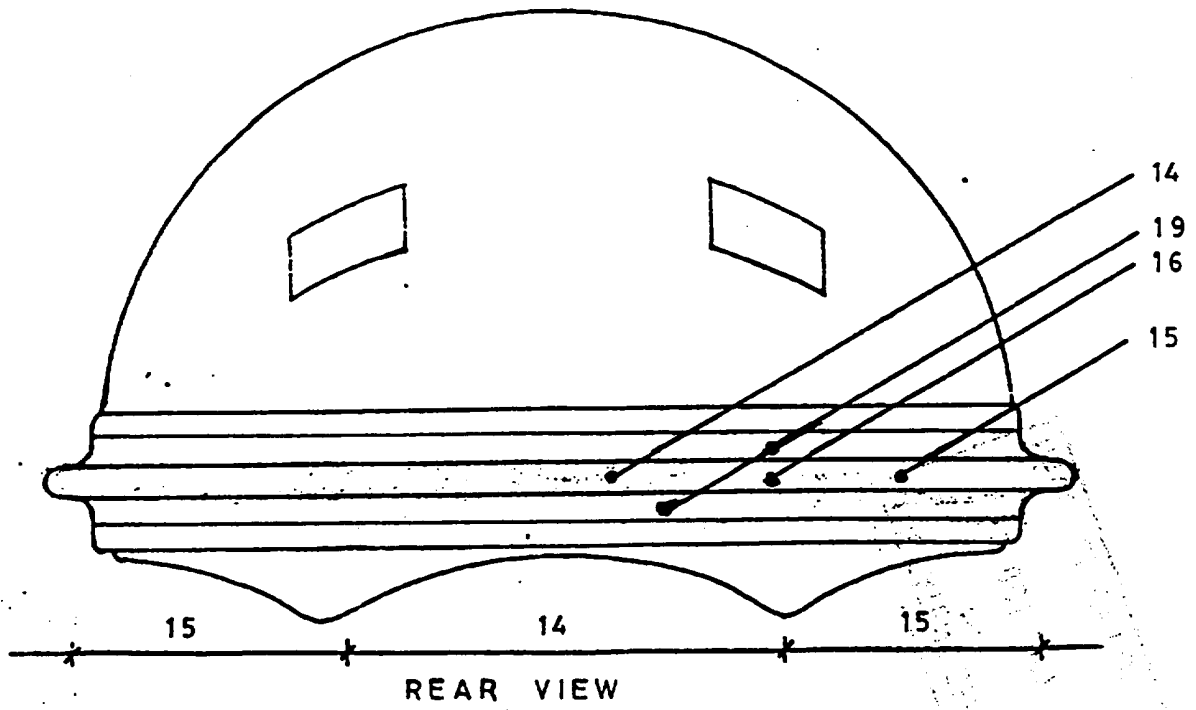
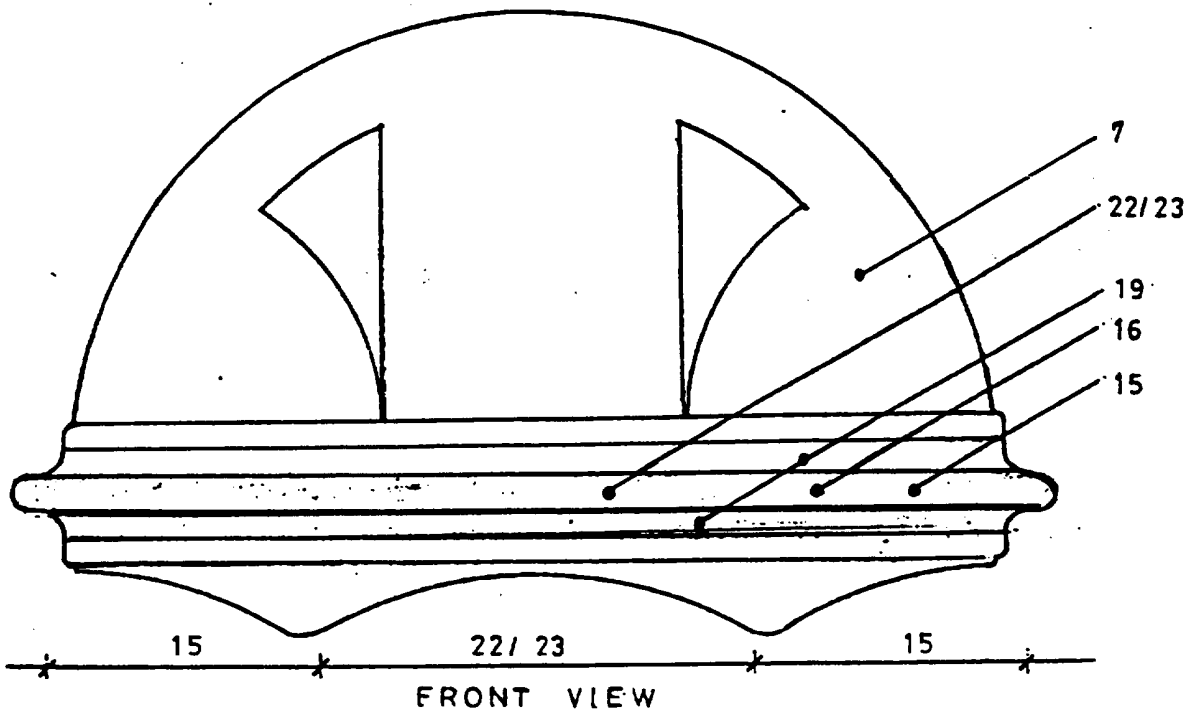

**LIGHTING INSTALLATION FOR CRASH HELMET
ESPECIALLY, BUT NOT EXCLUSIVELY, A MOTOR
CYCLE HELMET AND A CYCLE HELMET.**

BACKGROUND TO INVENTION

In order to improve safety standards and awareness of vehicle braking systems the automotive industry has largely adopted the incorporation of eye-level stop lights in addition to the statutory, low level stop lights. This has resulted in an appreciable reduction in rear end collisions due to the more readily visible stop lights.

However, motor cycles do not provide the same facility for mounting eye-level stop lights, and their normal stop lights can often be hidden by the bonnets of cars following behind. In addition to this their rear indicator lights are also often hidden from following traffic, particularly in dense, closely packed traffic.

A convenient way of making both stop and indicator lights on motor cycles clearly visible at eye-level to following traffic is to mount them on the rider's crash helmet, controlled to operate simultaneously with the corresponding lights on the motor cycle.

With the constant increase in vehicular traffic on the roads, and the increase in cyclists also using the roads, the matter of rider safety has become a major consideration. The dangers to cyclists increase dramatically at dusk and at night time, when reduced visibility becomes of critical importance.

In order to overcome the dangers arising from poor visibility a number of protective devices have become popular, such as brightly coloured and reflective clothing, reflective belts, and outrigger reflectors. However no system exists at present which enables cyclists to give directional turn signals or stop signals which are clearly visible to following traffic, or oncoming traffic, particularly in the dark.

A convenient and clearly visible method of overcoming this problem is to install a system of battery powered lights on the cyclist's crash helmet, with control switches mounted on the handlebars of the cycle.

SUMMARY OF THE INVENTION

The invention comprises a continuous, slender curved lighting channel containing a continuous row of Light Emitting Diodes (LED's) and extending along any of both sides and the rear of the helmet, or possibly at the front of the helmet. Two separate variations of the invention are proposed, to enable the invention to be incorporated into new helmets during manufacture, and to enable the invention to be retro-fitted to existing helmets. Both systems incorporate the same preferred principles as follows :

1.) HELMET INTEGRATED LIGHTING SYSTEM (HILS) FOR MOTOR CYCLE CRASH HELMET

This comprises a continuous curved lighting strip, inset flush with the contour of the external surface of the helmet, to provide a smooth, continuous and unbroken surface throughout.

The flush mounted external lens of the lighting strip is fixed permanently to the helmet shell during manufacture, by an impact adhesive or other means, and the lighting installation is fitted to the shell from the inside, prior to the installation of the internal foam padding to the helmet, which is detachable over the area of the lighting strip to provide access.

A continuous open slot is formed in the helmet during construction, extending full width across the rear of the helmet and part way along both sides. This slot accommodates the continuous curved lens which covers both the rear stop light and the two indicator lights. The helmet shell is thickened throughout the length of the slot, and around both

ends, to provide additional reinforcement and to provide suitable fixings for the curved lighting channel, which is screw-fixed along the internal length of the slot.

The lighting channel comprises a curved metal or plastic channel to accommodate a continuous row of LED's, together with an internal wiring channel to accommodate the separate wiring circuits to each of the lights, and the entire assembly is fitted into the inside of the slot and supported by a continuous curved metal or plastic baseplate which is screw-fixed with countersunk screws to brass sleeves cast into the thickened shell of the helmet. The thickening of the helmet shell, together with the fixed metal or plastic baseplate, is designed to ensure that the structural strength of the helmet is fully maintained.

The continuous lens covering the lighting strip is designed to appear as neat and unobtrusive as possible, and is expressed externally as a narrow black strip around the sides and rear of the helmet, and may be close to the base. The lens is constructed in dark grey or black Polymethyl Methacrylate (PMMA), thus concealing the light source from view when not in operation. As super-bright, high intensity LED's constitute the light source for each of the lights, red for the stop light and orange for the indicator lights, the light signal in operation is extremely bright and clearly visible through the translucent, tinted PMMA lens.

The number of LED's used for each light fitting will vary according to the perimeter dimension of the supporting helmet, however the normal installation envisaged comprises sixteen red LED's for the stop light and sixteen orange LED's for each of the indicator lights. In order to provide as neat an installation as possible the design is based on 5mm diameter LED's. although other sizes and types of lamps may also be used. The standard installation

envisaged will therefore comprise a continuous row of 48 LED's extending around the rear and sides of the helmet.

The foam insulation lining within the helmet will be adapted to accommodate the lighting installation without loss of performance or comfort, and will be attached to the helmet by Velcro^(SM) (C) or other means to permit it to be easily detached to provide access to the lighting channel.

The lighting circuits terminate in a jack-plug socket fitted into the base of the foam lining to the helmet, and this accommodates a male jack-plug with a trailing flexible cable. This cable can be attached to a belt or to cable clips fitted to the rider's clothing and extends to a coiled, flexible extending cable with a male jack-plug which is plugged into an auxiliary lighting socket fitted to the instrument console of the motor cycle. This system permits easy disengagement from both the motor cycle and the helmet, in normal operation and in the event of an accident. The console socket will be wired directly to the wiring circuits serving the stop light and both indicators, thus ensuring that the corresponding lights on the helmet will operate simultaneously with those on the motor cycle.

An alternative method of controlling the lights is by radio transmitter mounted on the motor cycle console, and activated by signals from each of the lamps, which activates the helmet lights by means of a receiver unit mounted within the helmet.

The lighting track may be adapted to incorporate a rear light function, linked to the rear light of the motor cycle, although it is considered preferable not to have a constant rear light at eye level. If the rear light is incorporated then this may comprise a second row of LED's, above or below the stop light, or may form part of the same continuous band

of LED's.

2.) RETRO FIT LIGHTING SYSTEM

This system is generally similar to the integrated lighting system, but is applied externally to existing helmets. The system comprises a curved lighting channel containing three separate lighting circuits, and with a wiring channel incorporated. Once the lights have been assembled and tested they are then fitted into a continuous, curved clear plastic sheath which incorporates a dark grey or black tinted PMMA lens bonded permanently to the sheath. The sheath has a swept, curved profile on either side of the lighting channel to provide a smooth, curved interconnection with the external, curved surface of the helmet, and is tapered at its extremities. The sheath has a continuous opening slot along its inner surface, and the lighting assembly is fitted into it via this opening. Once the assembly has been completed the fitting is attached to the helmet by an impact adhesive applied along the full base of the sheath. The impact adhesive will be selected to provide a transparent fixing, and may be of a peelable nature to enable the installation to be removed for servicing, and then refitted.

The purpose of using clear, flexible plastic for the sheath is to enable the surface patterns or decoration of the helmet to be seen through the assembly, with the lighting strip expressed as a continuous, narrow black band around the helmet. The clear plastic used will require to be capable of resisting ultra violet degradation or discolouration due to exposure to the elements. The ends of the sheath will extend beyond the lighting track and will terminate in a tapered, aerodynamic point to provide a neat, streamlined appearance.

The wiring circuits will terminate in a jack-plug socket fitted to the underside of the helmet lining,

with the supply cable being fed through a small hole drilled in the helmet. Alternatively the socket may be mounted externally on the helmet, at the end of the lighting track, and designed in a neat, streamlined shape. The wiring installation would be as previously described for the HILS, and the system may also be controlled by transmitter and receiver as described previously.

An alternative method of fixing the lighting track to the helmet may be by means of a Velcro strip glued to the surface of the helmet, with a corresponding strip or strips fitted to the underside of the sheath. However this would be less attractive visually, and would not provide as smooth a visual transition from the helmet to the lighting channel. Other, suitable means of fixing the track to the helmet may also be designed.

As the style and size of helmets vary widely the length of the lighting strip will vary accordingly. Smaller perimeter helmets may require the lights to be reduced to twelve or eight LED's per fitting.

A variation on the sheath design may incorporate a circular, clear plastic tube with rear entry slot, with the lighting track containing the PMMA lens which is fitted into continuous slots on either side of same following the installation of the LED's. This would enable the lighting strip to be rotated within the tube to compensate for the angle of the helmet, so that it would be in a horizontal position throughout its length. The rotation position of the lighting strip would be determined by trial and error within the sheath, placed in position, prior to final fixing of the sheath to the helmet.

The invention can be applied to a cycle helmet as a variation. The invention for a cycle helmet can comprise a continuous, slender curved lighting channel containing a series of continuous rows of Light Emitting

Diodes (LED's) extending around the base of the helmet and installed during manufacture as an integral part of the helmet construction.

This is designated as the Cycle Helmet Integrated Lighting System (CHILS).

In order to provide a similar facility which can be fitted to existing helmets a separate design has been invented, and this is fitted to the exterior of the base of the helmet.

Both systems incorporate the same preferred principles as follows :

1.) CYCLE HELMET INTEGRATED LIGHTING SYSTEM (CHILS)

This comprises a continuous curved lighting strip inset flush with the contour of the external surface of the helmet, to provide a smooth, continuous and unbroken surface throughout. The flush mounted external lens of the lighting strip is fixed permanently to the helmet during manufacture, and the lighting installation is fitted to the shell from the inside, and then covered by a detachable foam padding.

The helmet is manufactured in two parts, comprising the top or dome of the helmet and a corresponding base perimeter ring. The helmet dome and base ring are thickened to accommodate cast-in screw anchor-sleeves to provide a structural fixing for the lighting strip. The dome and base ring are first of all joined together by installing the continuous curved lens, and this is fixed to both parts by means of a strong impact adhesive. Once this has set fully the internal lighting ring is built up to specification, tested, and then inserted into the continuous slot formed.

The lighting channel is attached to, and supported by a continuous metal or plastic baseplate hoop, which is fixed securely to the helmet by means of a

series of countersunk screws which locate into the cast-in sleeves. The construction is then completed by fixing detachable foam padding to the inner surface of the base of the helmet.

The lighting channel comprises a continuous curved metal or plastic channel in H formation, with the inner channel housing separate wiring circuits for the various light functions selected, and the outer channel containing a continuous reflective band and a series of function lights, each of which comprises a continuous row of LED's, in appropriate colours.

A jack-plug socket is built into the base of the helmet, and this accommodates a jack-plug connector with a flexible, expanding cable connection to the handlebar control switches. The handlebar control switches are in turn supplied by a rechargeable battery pack, either Lithium or other suitable type, and possibly located below the saddle, or elsewhere on the cycle. The flexible cable may be connected to an intermediate socket fitted to a belt worn by the cyclist to facilitate disconnection on dismounting.

The lighting control switch will be constructed to correspond with the number and type of lighting functions selected or specified. The following selection of lights, and functions, will be available, and can be pre-ordered and installed in the factory, or alternatively can be installed by the cycle dealer to the customer's specification.

- 1.) **Rear stop light** - super bright red LED's.
- 2.) **Left and right indicator lights**
super bright orange LED's.
- 3.) **Front light** - super bright white flicker LED's.

It is envisaged that a standard light will comprise eight or twelve LED's in a continuous strip, and in the appropriate colour. A normal installation may comprise a front white flicker light, two front

quadrant orange indicator lights, two rear quadrant orange indicator lights, a rear red flicker light and a rear red stop light.

Market research will require to be carried out to determine the optimum lighting arrangement. An alternative arrangement may be to provide a double row of red LED's at the rear, with the upper row comprising red flicker lights and the lower row comprising a super bright stop light.

Lighting control will be effected by means of handlebar-mounted toggle switches to give front and rear light control, and turn indicator light controls, and the composite control switch will be built up to match the lighting selection specified by the customer. The stop light will be controlled automatically by electrical contact switches mounted on both brake levers and activated by braking.

The spaces between the light fittings will contain the reflector strip set within the lighting channel, and this may vary from red at rear and halfway along the sides to white at front and halfway along the sides. Where the front flicker light and front indicator lights are omitted the white reflector band will show.

The continuous lens cover running round the base of the helmet will be constructed in black or dark grey Polymethyl Methacrylate (PMMA), or other suitable material, which will conceal the entire lighting assembly from view, when not in operation, but will allow the lights to shine through clearly when lit. Similarly the reflector strip will show up clearly when illuminated by car headlamps.

The number of LED's incorporated in each fitting may vary according to helmet size and customer requirements, and the size and type of LED or other light source may also vary. It is anticipated that the minimum practical number of 5mm LED's per fitting is

eight. If required, it is possible to install a continuous lighting strip around the helmet, with red at the rear, white at the front, and orange at the sides and on both front and rear quadrants.

2.) RETRO FIT LIGHTING SYSTEM

This system is generally similar to the integrated lighting system, but is applied externally to existing helmets. The system comprises a similar curved lighting track with reflective sole plate, and this is fitted to the helmet with a two part streamlined clear plastic sheath, which is fixed direct to the helmet by a suitable clear adhesive, or other means.

The selected lights are first of all installed in the lighting track and tested, and the installation is then fitted into the sheath, which is then fitted to the helmet. The sheath is flexible and transparent, and may incorporate the black or dark grey PMMA lens which may be permanently bonded to it. Alternatively the PMMA lens may be fitted along the outer face of the lighting track by sliding it into continuous grooves on either side, and the completed track is then inserted into the sheath.

The angle and curvature of helmets vary widely, in an effort to obtain optimum aerodynamic efficiency, and the fitting of the lighting strip at right angles to the surface of the helmet may result in the lights pointing upwards. In order to provide a facility for adjusting the lighting track to a horizontal position, for all angles of helmet, an alternative clear plastic sheath is proposed, which incorporates a continuous, circular, clear plastic tube as an integral part. The lighting track, which incorporates the PMMA lens, is inserted into the sheath via a continuous slot along the rear surface. Prior to fixing the sheath to the helmet the lighting track can be rotated into the desired position within the tube, by trial and error.

The wiring system is connected to the helmet via a jack-plug and socket arrangement, and this can either be installed within the thickness of the helmet, with the cable passing through a hole drilled in the helmet, or alternatively may be mounted externally as part of the lighting track installation. The lighting controls and wiring installation are as described for the CHILS previously.

The power source for the lighting installations may be a Lithium, or other type of rechargeable battery, mounted in a weatherproof cover, and located either below the saddle or elsewhere on the cycle. An alternative power source may be a dynamo, mounted on a wheel of the cycle, although this would become progressively less effective at slow speeds, which is possibly when power for the installations is most required. In order to overcome this drawback the dynamo may be used to recharge the battery, thus providing continuous battery power when required.

Other power options may be adopted to provide the optimum and most cost effective power source for the installations.

Specific embodiments of the invention will now be described by way of example, with reference to the accompanying drawings Nos 1/11 to 11/11.

Drawing 1/11

This shows the complete Helmet Integrated Lighting System (HILS) for a motor cycle, comprising motor cycle rear light 1 with corresponding helmet rear light 1, left hand front and rear indicator lights 2 with corresponding helmet left hand indicator light 2, console mounted socket 3, motor cycle jack-plug 4, flexible, extending cable 5 and belt mounted intermediate socket 6.

Drawing 2/11

This shows a cut-away section through a motor cycle crash helmet, fitted with HILS during manufacture. This comprises structural helmet shell 7, foam padding 8,

detachable foam padding strip 9, fitted along the rear, inner face of lighting installation base plate 11, with Velcro (C) or other detachable fixing 15. The shell of the helmet is thickened 10 to provide additional strength and to provide built in fixings for the lighting track baseplate 11. A continuous curved PMMA black or dark grey tinted lens 12 is bonded permanently to the helmet shell 7, flush with the external surface.

A continuous row of closely spaced super-bright red LED's 14, (or other colour as appropriate), is fitted within the lighting channel, with separate wiring circuits located within the continuous wiring channel 13, and connected to each of the lighting installations as appropriate.

Drawing 3/11

This shows a retro-fitted lighting system fitted to an existing motor cycle crash helmet.

This comprises helmet shell 7, foam padding 8 and lighting track 12, fitted within surface mounted clear plastic shroud 19. A jack-plug socket 16 is fitted to the helmet padding or shell, to accommodate a jack-plug 4 connected to a flexible, extending cable 5, which is in turn connected to the motor cycle console socket by means of a further jack-plug 4.

Drawing 4/11

This shows a plan view and section through a motor cycle helmet fitted with HILS.

The structural shell of the helmet 7 is thickened 8 to accommodate the lighting track which comprises fixed, curved PMMA lens 16, orange super-bright LED's 15, red super-bright LED's 14, wiring channel 13, curved structural baseplate 12, Velcro (C) or other detachable fixing 15 and detachable foam padding strip 10, located along the inner face of the lighting track baseplate.

Drawing 5/11

This shows side and rear views of a motor cycle crash helmet fitted with HILS.

Helmet shell 7 incorporates a continuous slot to sides and rear 17, fitted with PMMA tinted lens 16 which con-

ceals red LED's 14 and orange LED's 15. Helmet mounted socket 16 accommodates pull-out jack-plug 4 fitted to flexible, extending cable lead 5.

Drawing 6/11

This shows a motor cycle crash helmet fitted with a retro-fit lighting system.

This shows a continuous transparent plastic sheath 19 fitted to the lower sides and rear of the helmet shell 7, and containing continuous dark tinted PMMA lens 16, which conceals red LED's 14 and orange LED's 15, and with continuous wiring channel 13 incorporated.

Drawing 7/11

This shows a rear elevation of a motor cycle crash helmet fitted with a retro-fit lighting system.

Helmet shell 7 has fitted to it, with peelable adhesive, transparent plastic shroud 19 containing curved, tinted PMMA lens 16, which conceals red LED's 14 and orange LED's 15. The clear plastic shroud 19 supports the lighting track, which is expressed as a continuous, dark tinted narrow band, with the colour and design pattern of the helmet visible through the shroud.

Drawing 8/11

This shows side view and plan/section of a cycle helmet fitted with Cycle Helmet Integrated Lighting System (CHILS).

The structural shell 7 of the helmet has a separate base ring 21 of the same material and construction, and bonded to the shell by a continuous, curved tinted PMMA lens 16 which is fitted permanently to the upper and lower parts of the helmet by a strong impact adhesive during manufacture. A continuous slot 20 is thus formed within the helmet construction into which is fitted a continuous lighting track supported on a curved metal or plastic baseplate 12 which is screw fixed to anchor-sleeves cast into the thickened helmet shell above and below the slot. The baseplate 12 is fitted with a continuous wiring channel 13, a continuous lighting channel 24 fitted with a reflective band 22 on its outer, exposed surface in red or white as appropriate. A series of lights are fitted

into the lighting track 24 comprising rows of red LED's 14, orange LED's 15 or white LED's 23, which latter may be fitted with a flicker system to conserve energy. The size and disposition of the LED installations is at the cyclist's discretion, with each unit normally configured in 8 or 12 LED size.

Drawing 9/11

This shows front and rear views of a cycle helmet fitted with CHILS.

This comprises helmet shell 7 and base ring 21 bonded together with PMMA lens 16 fitted in continuous slot 20.

The lens conceals red LED's 14, orange LED's 15, white flicker LED's 23 (optional) or white reflective strip 22.

Drawing 10/11

This shows side view and plan/section of a cycle helmet fitted with a retro-fit lighting system.

Helmet shell 7 is fitted with a continuous clear plastic shroud 19 which contains a continuous, curved tinted PMMA lens 16 which conceals red LED's 14, orange LED's 15, white flicker LED's 23 and continuous red or white reflective strip 22. These are fitted to lighting channel 24 which incorporates wiring channel 13 and continuous curved metal or plastic baseplate 12 which is fitted within the shroud 19. The lighting channel is in two curved sections and the light systems selected are fitted into it and wired up as appropriate, prior to fitting the entire system to the helmet.

The shroud incorporates a continuous rear access slot to facilitate fitting of the lighting track, and is attached to the outer surface of the helmet with a peelable adhesive or other fixing method to enable future maintenance access to the wiring and lighting installations.

Drawing 11/11

This shows front and rear views of a cycle helmet fitted with a retro-fit lighting system.

Helmet shell 7 has fitted to it a continuous clear plastic shroud 19 containing a continuous curved, tinted PMMA lens which conceals red LED's 14, orange

LED's 15 and white flicker LED's 23 or white reflective strip 22.

The lighting systems may also be adapted for use in riding helmets worn by mounted Police to provide rear light, stop light and turn indicator light functions, fed by rechargeable battery power.

As the design of certain aerodynamic cycle helmets would not suit a continuous slot formed around the base the light functions may be separated and contained in a series of narrow slots located around the periphery of the helmet as appropriate.

The invention provides the following advantages :

- 1.) The essential design feature of the invention is the neatness of the narrow lighting track, and its concealment from view when not in operation. This is based on a 5mm diameter LED format, with the curved lens formed in black or dark grey tinted PMMA.
- 2.) The lens is permanently bonded to the exterior of the helmet shell and is inset flush with the surface, thus achieving a highly aesthetic and unobtrusive appearance.
- 3.) The light source comprises a continuous row of closely spaced LED's in appropriate colours, and using super-bright lamps for maximum illumination and effect.
- 4.) The lighting track forms a structural element within the helmet shell and reinforces the structural integrity of the shell along the continuous slot formed during manufacture, to receive the track. In addition the track is fitted internally and can be withdrawn to facilitate servicing of the lamps or wiring.
- 5.) The system is designed to be incorporated into the shell during manufacture so that there is no loss of structural performance, and to ensure that an exact match is achieved between the inset lens and the curvature of the helmet shell.
- 6.) The lighting system does not incorporate a rear light function for a motor cycle crash helmet as it is considered that this may not be of any significant benefit. However if this does become a desirable feature then it can easily be incorporated within the general design proposals as outlined previously.
However a rear light function is more desirable for a cycle helmet and this can be incorporated as outlined previously.

- 7.) Hard wired connection between the helmet and the motor cycle is specified as against electronic or radio wave transmission, as the latter are prone to external interference with present day technology. However advances in this field may result in remote control technology becoming a more suitable system. The hard wired system proposed incorporates a jack-plug system similar to that currently used by Police motor cyclists for communications.
- 8.) The retro-fit system for use with existing helmets has also been designed to provide a neat, unobtrusive and highly aesthetic appearance, with full provision for future access for maintenance, or for adding additional lighting units if desired.
- 9.) The retro-fit system can be adapted to ensure that the lighting is fitted in a horizontal position, irrespective of the angle or curvature of the helmet.
- 10.) The invention is not confined to motor cycle crash helmets, but is also designed to be fitted to cycle helmets, either during manufacture or on a retro-fit basis. It can also be adapted for use on horse mounted Police helmets.
- 11.) A single, continuous, curved, black or dark grey lens is used, to provide a neat and simple design statement to complement the pure spherical curvature and highly polished surface of the present day crash helmets, which have become an art form in their own right.

CLAIMS

1. A crash helmet for a road user, especially a motorcyclist or cyclist, said helmet comprising a shell and warning light means carried by the shell, said warning light means comprising an elongate lighting unit including a light source and a lens, the helmet shell having an elongate open-sided slot to receive said lighting unit, said lens being located at the external side of said slot and the arrangement is such that the light source can be removed via the internal side of the slot.

2. A crash helmet for a road user, especially a motorcyclist or cyclist, said helmet comprising a shell and warning light means, said warning light means comprising an elongate track carrying a light source, said helmet including an elongate recess to receive said track, fastening means securing the track to the helmet, and a lens covering said light source.

3. A helmet as claimed in claim 1 or 2, wherein the lens is fitted flush with the helmet shell.

4. A helmet as claimed in any one of the preceding claims, wherein the shell is thickened at the zone of the slot or recess.

5. A helmet as claimed in any one of the preceding claims, including a track of H-form cross-section with two opposing U-formations, one of the U-formations serving to houses the light source while the other U-formation houses wiring for the supply of electricity to the light source, the open end of said other U-formation being closed by a base plate serving to assist in maintaining the structural integrity of the shell.

6. A helmet as claimed in claim 4, wherein the track is secured to the shell by screws.

7. A helmet as claimed in any one of the preceding claims, wherein the lens is a coloured opaque lens concealing the light-source when the latter is not lit.

8. A helmet as claimed in claim 1, wherein the shell is provided with internal padding, said internal padding including a removable internal padding portion located at the internal side of the elongate slot.

9. A helmet as claimed in any one of the preceding claims, wherein the light source comprises a multiplicity of light emitting diode (LEDS).

10. A helmet as claimed in any one of the preceding claims, wherein the slot or recess extends at the rear of the helmet and also on either side of the helmet, and the light source comprises a stop light source at the rear of the helmet and left and right turn indicator light sources on respective sides of the helmet.

11. A helmet as claimed in claim 9, wherein the light-source comprises LEDS, the stop light source and each of the indicator light sources comprising at least eight LEDS.

12. A helmet as claimed in any one of the preceding claims, including electrical connection means whereby the light source can be releasably connected to a source of electricity Eg motorcycle wiring system or an electrical battery.

13. A helmet as claimed in any one of the preceding claims, wherein means are provided to connect the light source to main control elements controlling any of the main stop light and indicator lights of a vehicle whereby

the light source of the helmet functions in unison with said lights.

14. A helmet as claimed in any one of claims 1 to 11, wherein receiver means are provided whereby operation of the light source is controlled by signals transmitted from a transmitter.

15. A helmet as claimed in claim 1 or 2, and constituting a cycle helmet, the shell comprising a main upper bowl shaped portion and a separate lower annular portion, the elongate slot being formed between said upper and lower portions, means being provided to join the upper and lower portions

16. A helmet as claimed in claim 15, wherein the upper and lower shell portion are joined together by the lens.

17. A helmet as claimed in claim 15, wherein the light source extends completely around the helmet and comprises a stop light source at the rear of the helmet, a front light source and indicator light sources on either side of the helmet.

18. A helmet as claimed in claim 17, wherein the front light source is of the flicker or flashing type.

19. A helmet as claimed in any one of the preceding claims wherein an appropriately coloured reflection strip is provided behind the light source.

20. A helmet as claimed in any one of the preceding claims, wherein the light source comprises a rear red light source.

21. A warning light device for fitting or retrofitting to a crash helmet comprising an elongate lighting

assembly including a light source and wiring for the supply of electricity to the light-source and a carrying member for the lighting assembly additionally carrying a lens for the light-source said carrying member being adapted for securement to a crash helmet by securing means.

22. A warning light device as claimed in claim 21, wherein said carrying member comprises a sheath having a base surface whereby the sheath is secured to a crash helmet by said securing means.

23. A warning light device as claimed in claim 22, wherein said sheath is made from clear or opaque plastics material.

24. A warning light device as claimed in claim 22 or 23, wherein said base surface of the sheath is adapted to permit insertion or removal of the lighting assembly into or from the sheath.

25. A warning light device as claimed in any one of claims 21 to 24 wherein the securing means are adapted to facilitate subsequent release of the carrying member from the crash helmet.

26. A warning light device as claimed in any one of claims 21 to 25, wherein the lens is a coloured lens for concealment of the light source when the latter is not lit.

27. A warning light device as claimed in any one of claims 21 to 26 wherein the securing means comprises an adhesive.

28. A warning light as claimed in any one of claims 21 to 27 wherein the light source provides any of (a) a stop light source at the rear of the helmet, (b)

indicator light sources on the sides of the helmet, (c) a front light source, and (d) a red rear warning light source.

29. A warning light device as claimed in claim 28, including connection means for connecting said wiring to an electrical power source and/or control means for controlling the operation of the light source.

30. A warning light device as claimed in claim 21 wherein the light source is angularly adjustable within the carrying member.

31. A warning light device as claimed in claim 21, wherein the carrying member is of tubular form.

32. An assemblage for a bicycle user comprising a crash helmet as claimed in claim 10, in combination with a first actuator for fitting to a bicycle so as to be operable by brake operation for functioning of the stop light source and a second actuator for fitting to the bicycle operable by the bicylce user for operation of the indicator light source.

33. A crash helmet including a warning light substantially as hereinbefore described with reference to and as illustrated in any of the figures of the accompanying drawings.

34. A warning light device for retro-fitting to a crash helmet substantially as hereinbefore described with reference to and illustrated in Figs 3/11, 6/11, 7/11, 10/11 or 11/11 of the accompanying drawings.



Application No: GB 9606839.0
Claims searched: 1 - 34

Examiner: Justin Black
Date of search: 17 June 1997

**Patents Act 1977
Amended Search Report under Section 17**

Databases searched:

UK Patent Office collections, including GB, EP, WO & US patent specifications, in:
UK CI (Ed.O): A3V
Int CI (Ed.6): A42B 3/04
Other: Online: WPI

Documents considered to be relevant:

Category	Identity of document and relevant passage	Relevant to claims
X	GB 1468323 (ZINER). Whole document relevant.	2 - 7, 9 - 32.
X	GB 1389980 (ZINER). Whole document relevant.	2 - 7, 9 - 13, 15 - 32.
X	WO 93 / 22160 A1 (ADONIS). See, for example, page 4 line 5 - page 5 line 23.	21 - 30.
X	US 4891736 (GOUDA). Whole document relevant.	2 - 7, 9 - 32
X	US 4559586 (SLARVE). See whole document, for example, column 2 lines 29 - 48.	2 - 7, 9 - 13, 15 - 32.

X	Document indicating lack of novelty or inventive step	A	Document indicating technological background and/or state of the art.
Y	Document indicating lack of inventive step if combined with one or more other documents of same category.	P	Document published on or after the declared priority date but before the filing date of this invention.
&	Member of the same patent family	E	Patent document published on or after, but with priority date earlier than, the filing date of this application.