



US 20050186070A1

(19) **United States**

(12) **Patent Application Publication**
Zeng et al.

(10) **Pub. No.: US 2005/0186070 A1**

(43) **Pub. Date: Aug. 25, 2005**

(54) **FAN ASSEMBLY AND METHOD**

(52) **U.S. Cl. 415/211.2**

(76) **Inventors: Ling-Zhong Zeng, Lake in the Hills, IL (US); Richard R. Shelby, South Elgin, IL (US); Michael F. Buckley, McHenry, IL (US)**

(57) **ABSTRACT**

Correspondence Address:

MICHAEL BEST & FRIEDRICH, LLP
100 E WISCONSIN AVENUE
MILWAUKEE, WI 53202 (US)

(21) **Appl. No.: 10/784,910**

(22) **Filed: Feb. 23, 2004**

Publication Classification

(51) **Int. Cl.⁷ F04D 1/10**

The axial fan assembly according to some embodiments of the present invention has a shroud, a motor coupled to the shroud, and a fan coupled to the motor. By employing selected vane-to-blade ratios, blade twist angles, blade pitch angles, blade-to-shroud axial gaps, shroud solidities, vane swept angles, and vane inlet and outlet angles of specified amounts or falling within specified ranges, desirable fan performance is achieved. Any one or more of these parameters can be utilized alone or in combination with other parameters as desired.

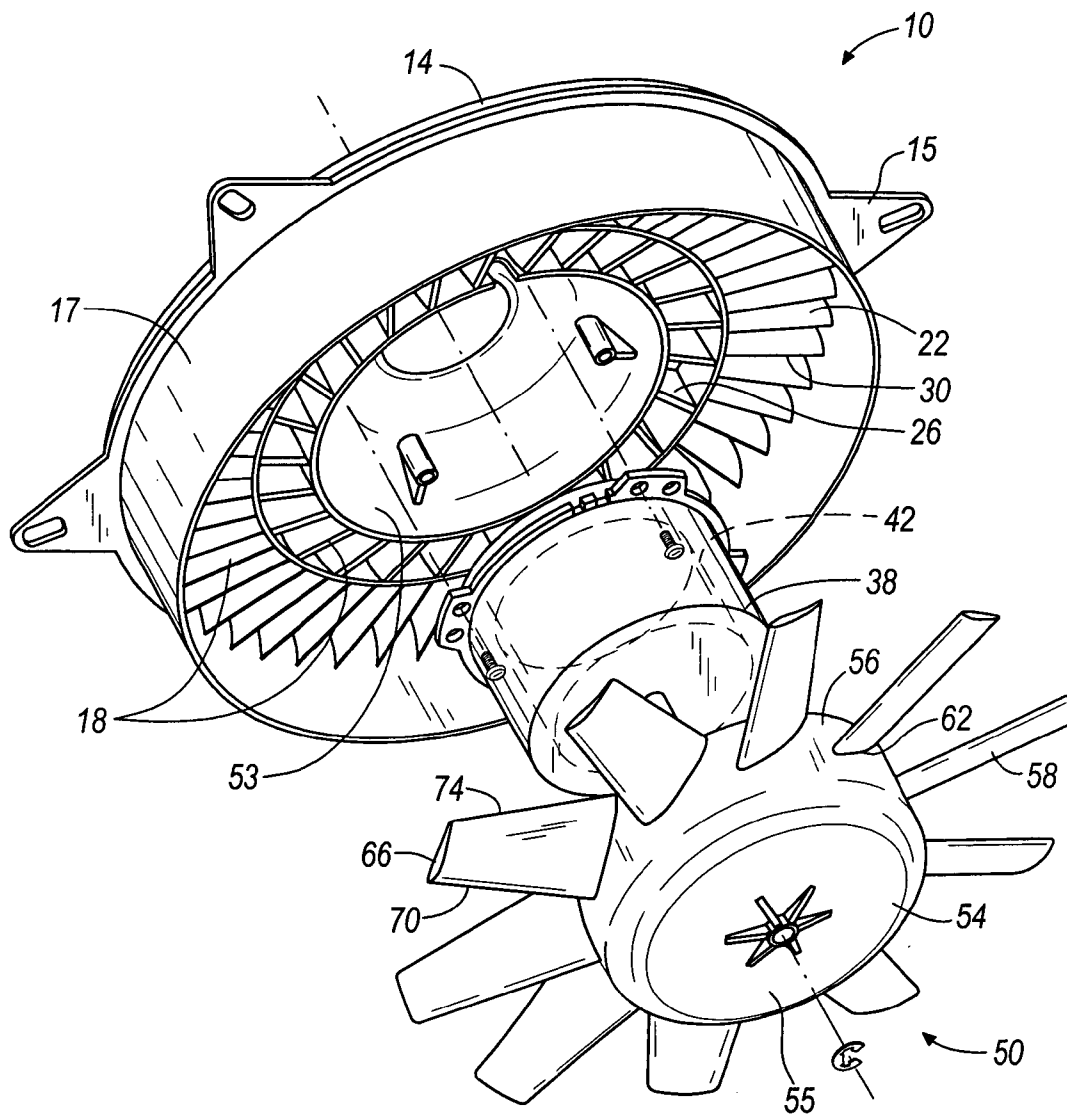

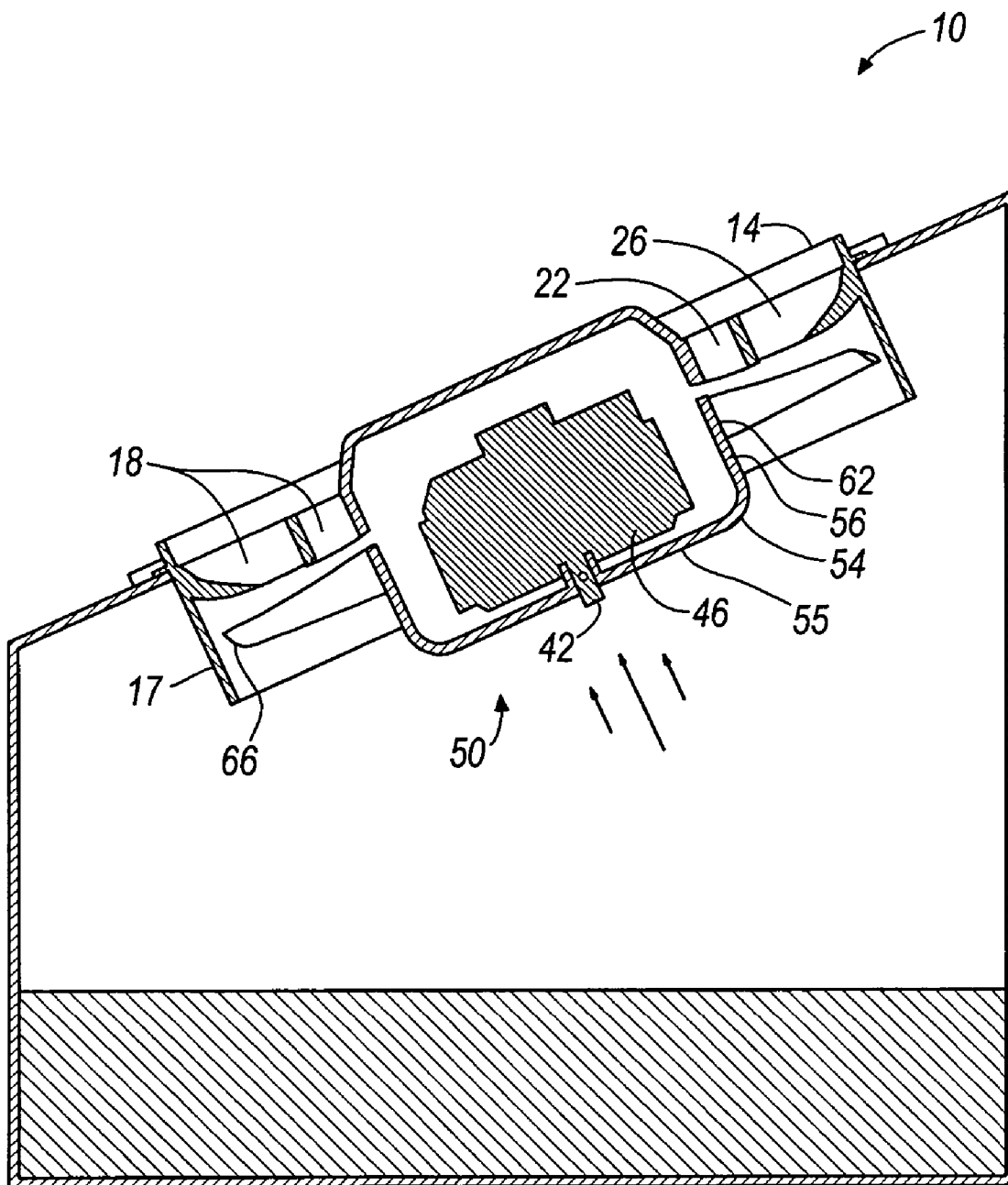

FIG. 1A

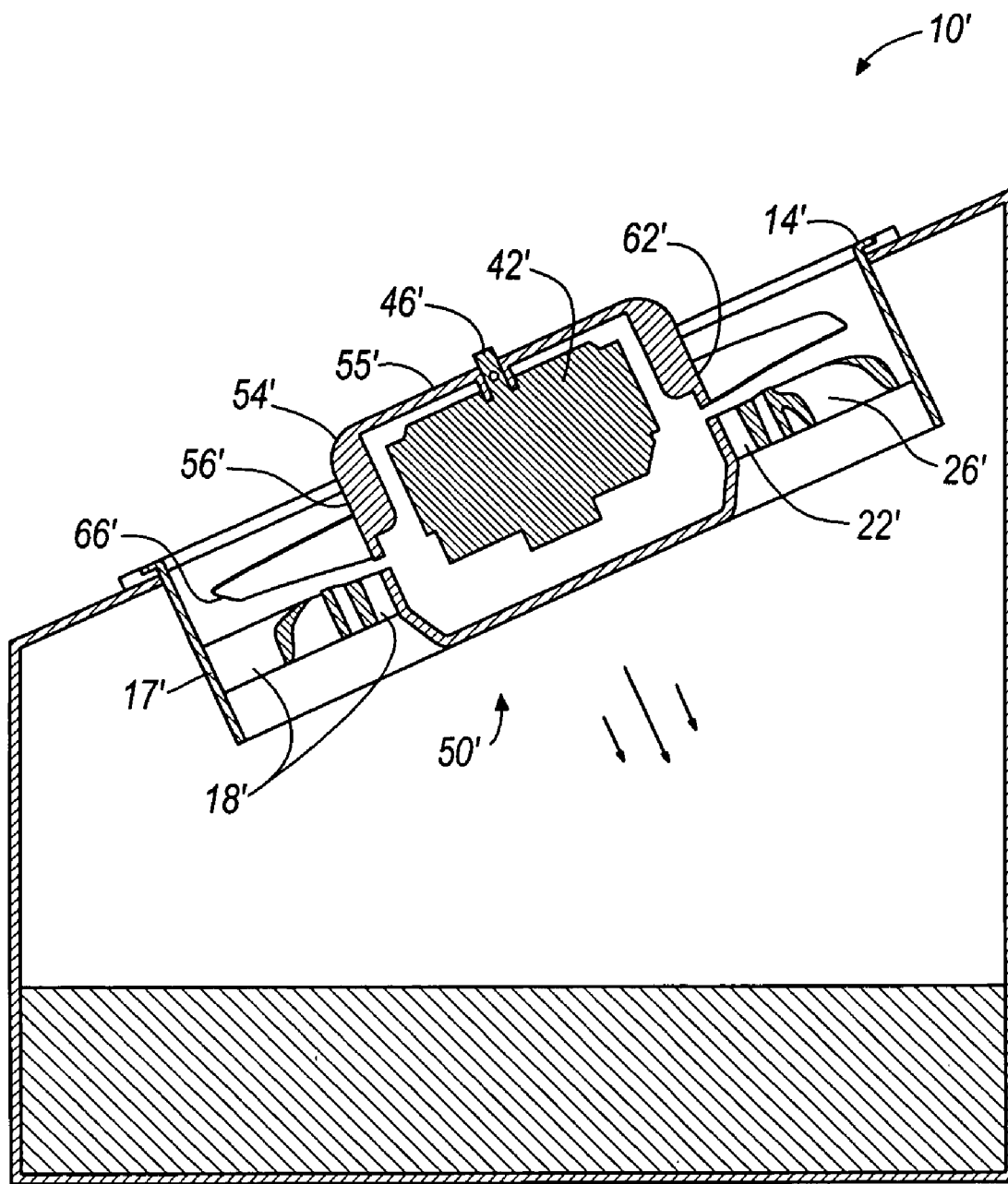

FIG. 1B

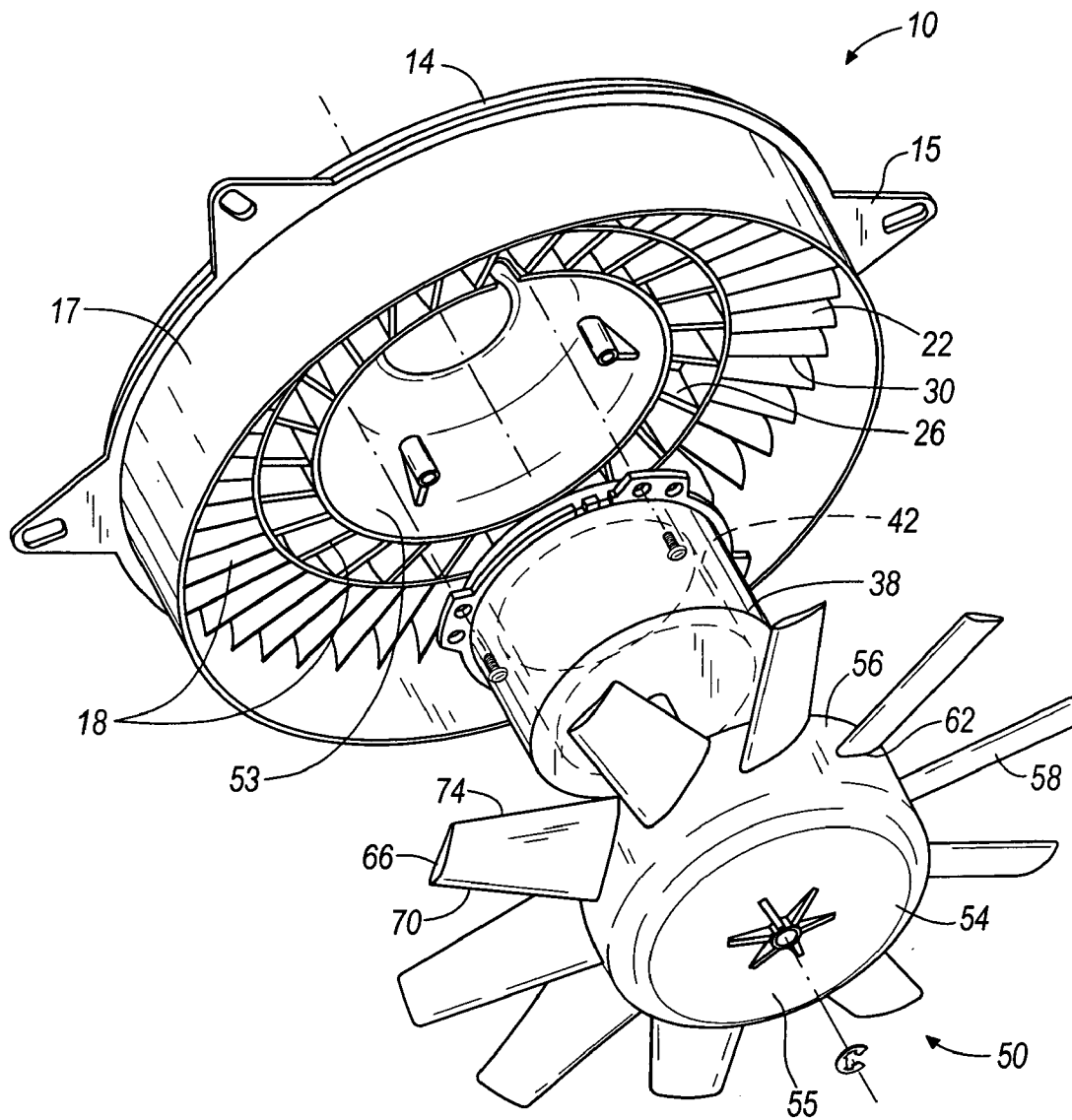

FIG. 2

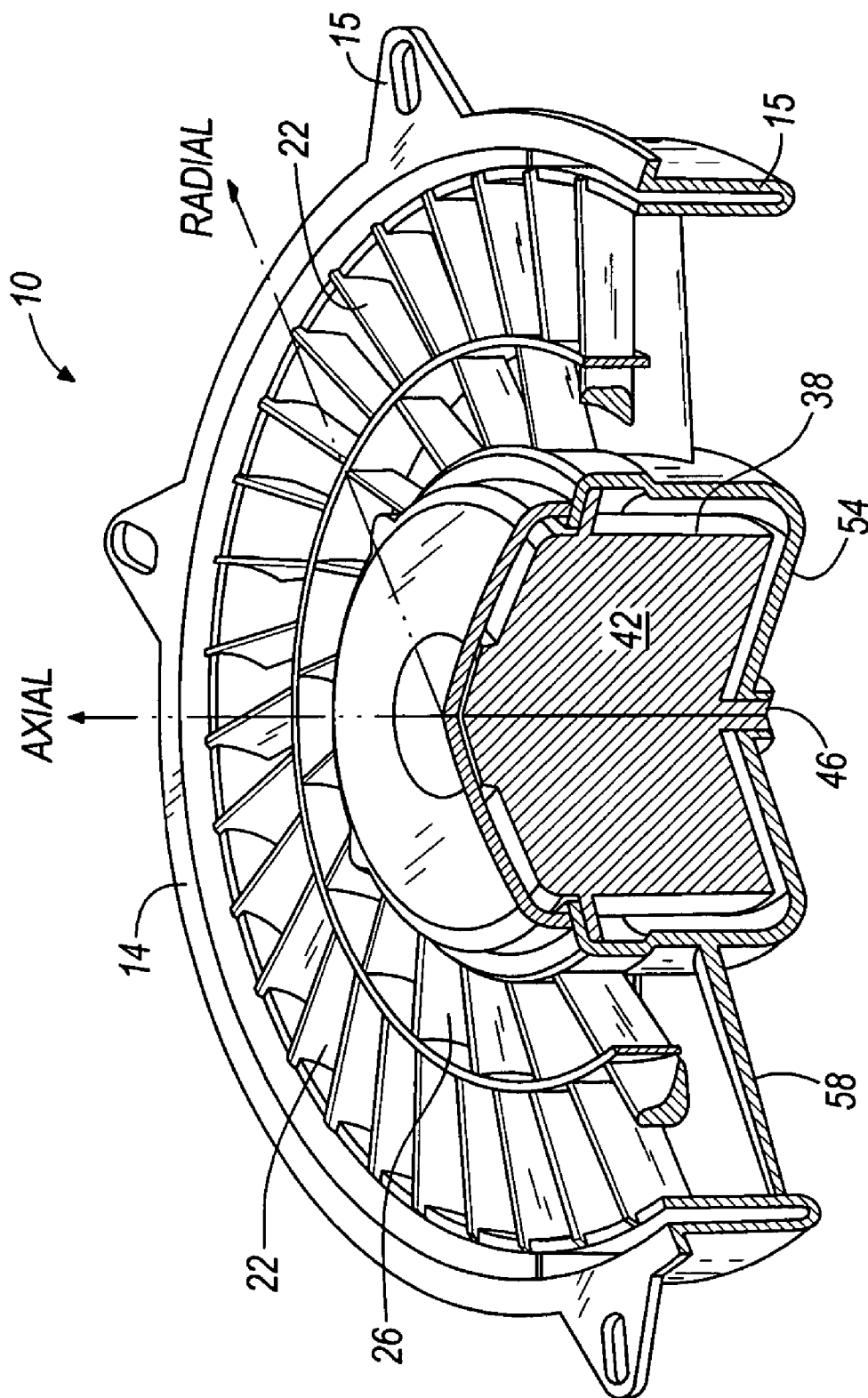

FIG. 3

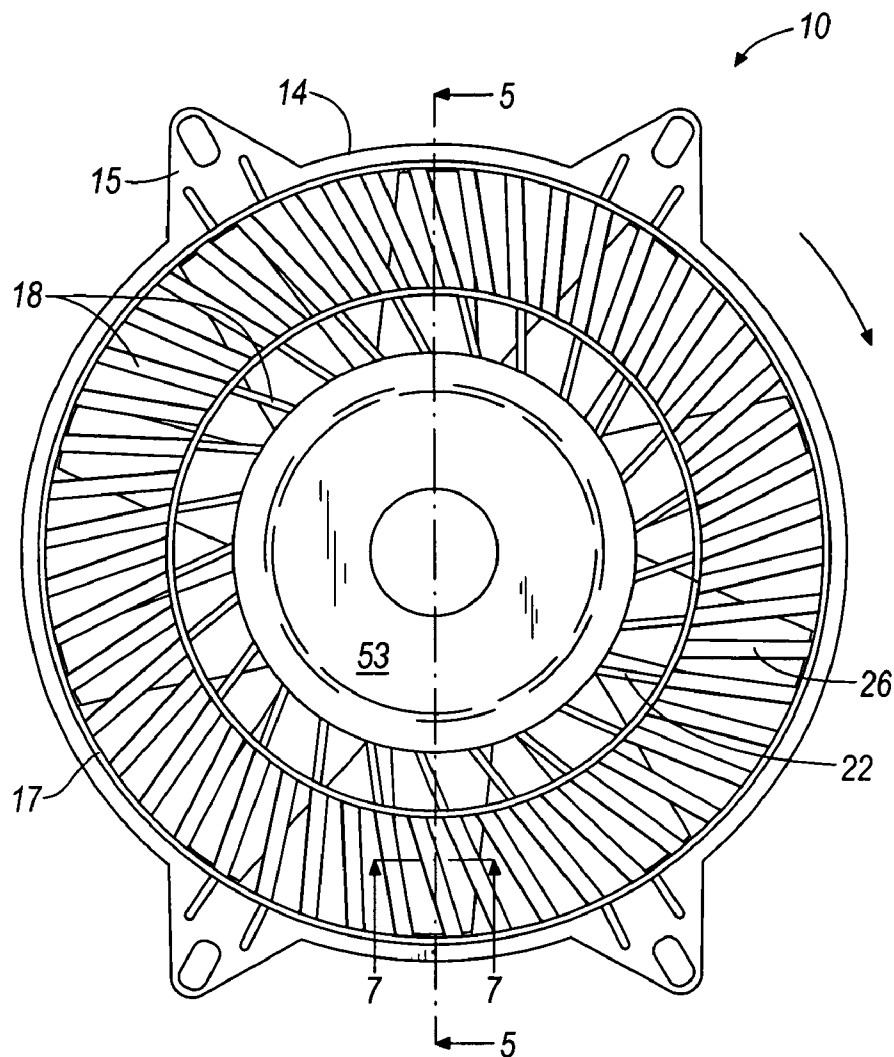

FIG. 4

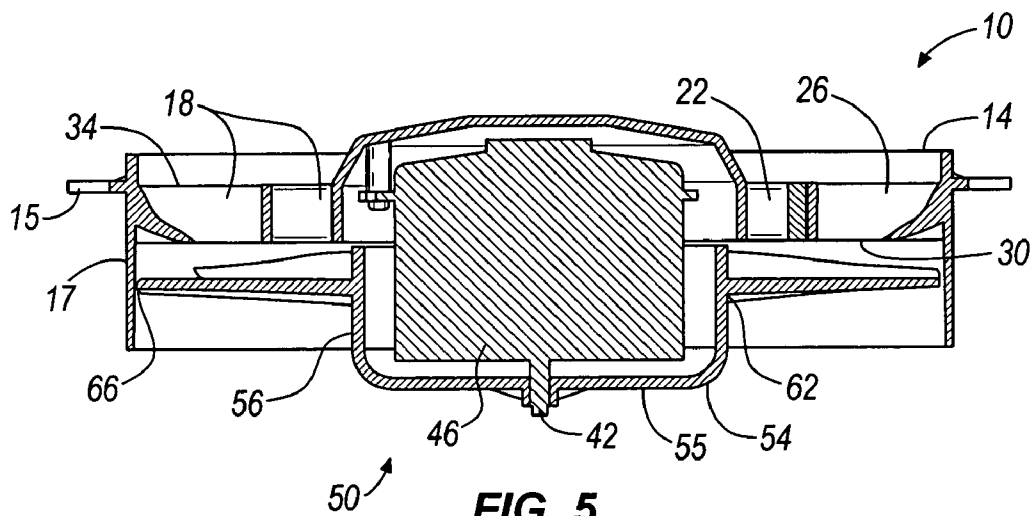

FIG. 5

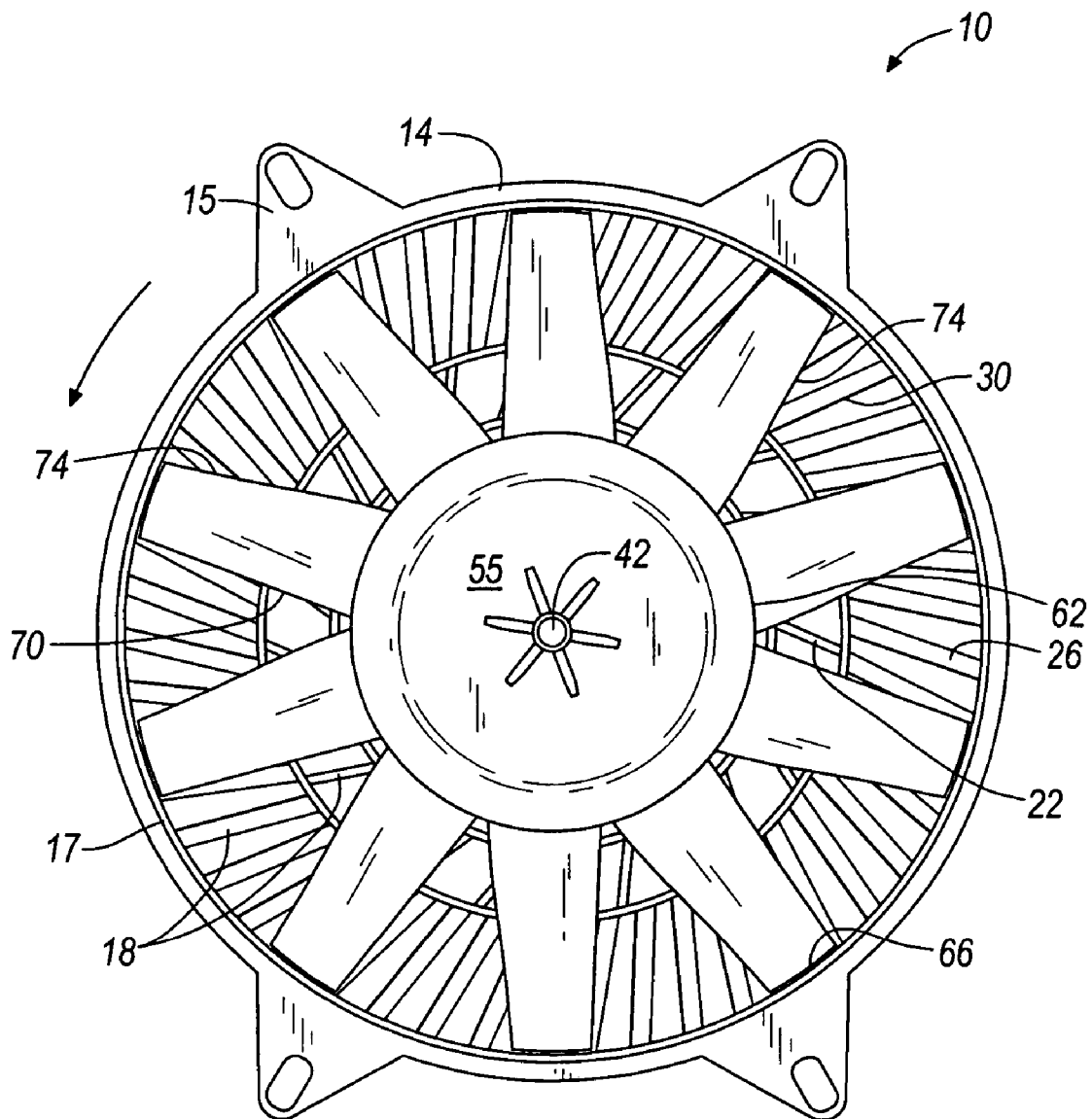

FIG. 6

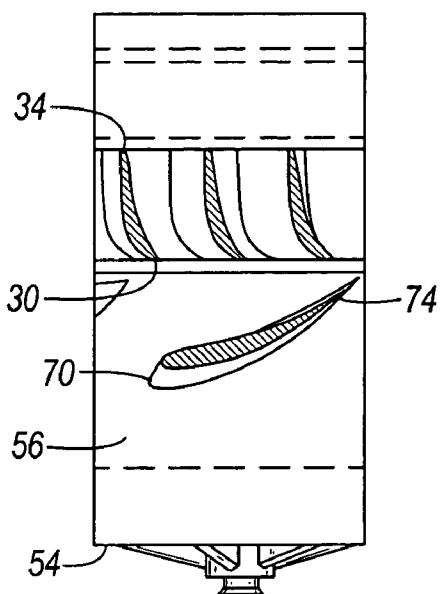

FIG. 7

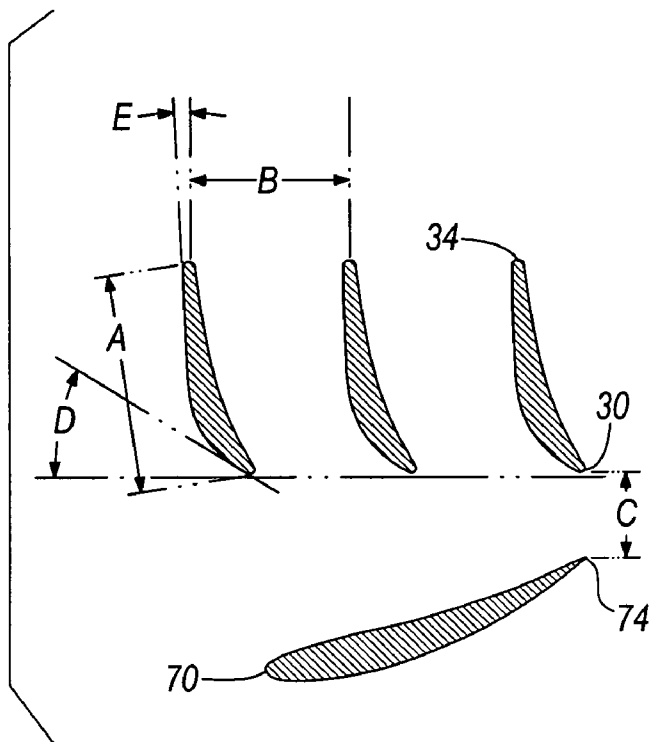

FIG. 8

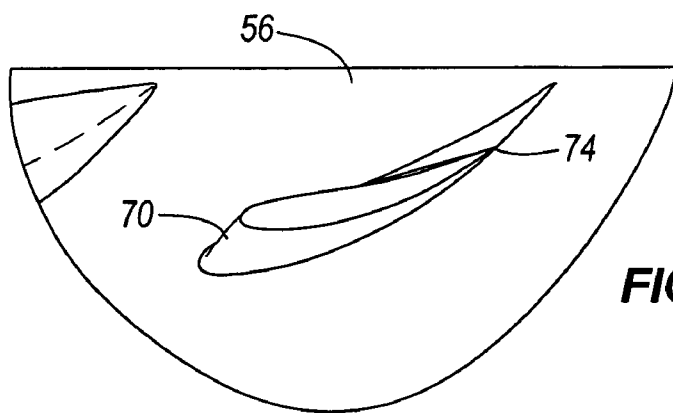

FIG. 9

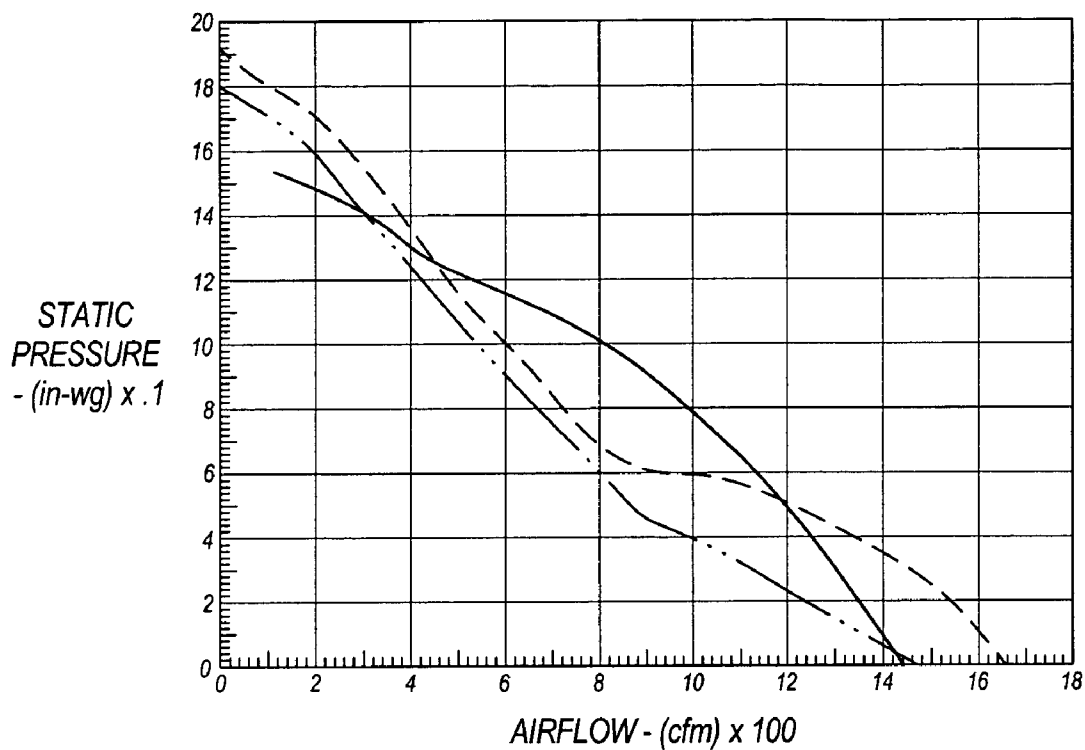

FIG. 10A

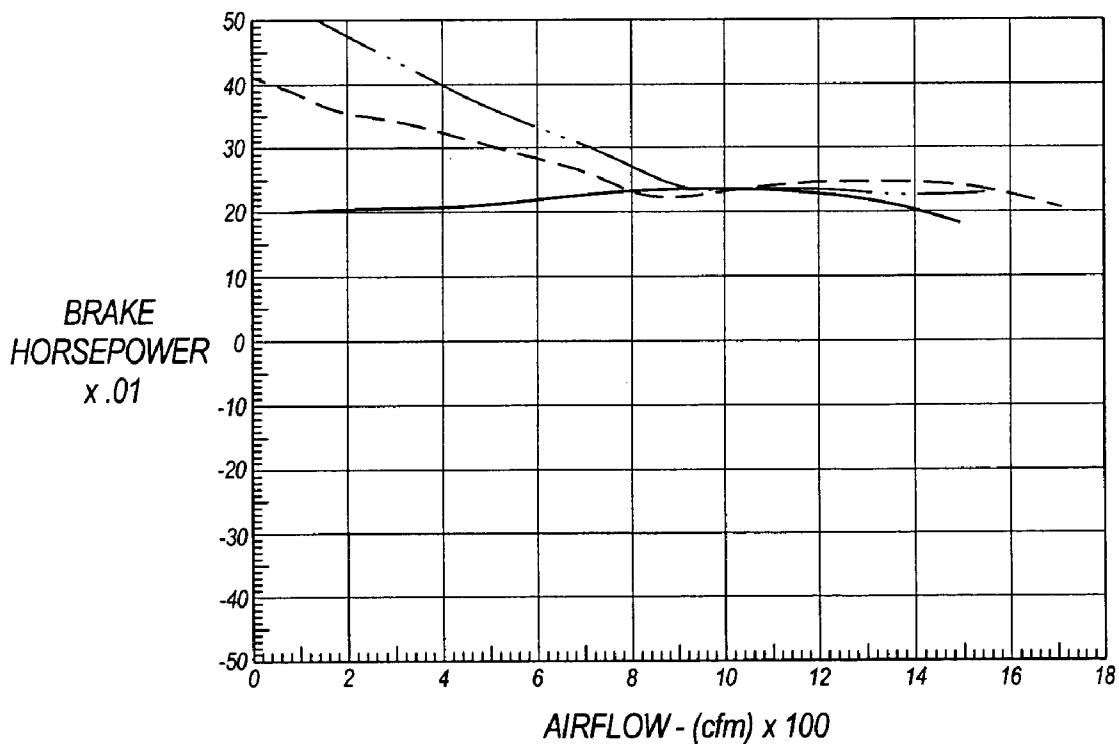

FIG. 10B

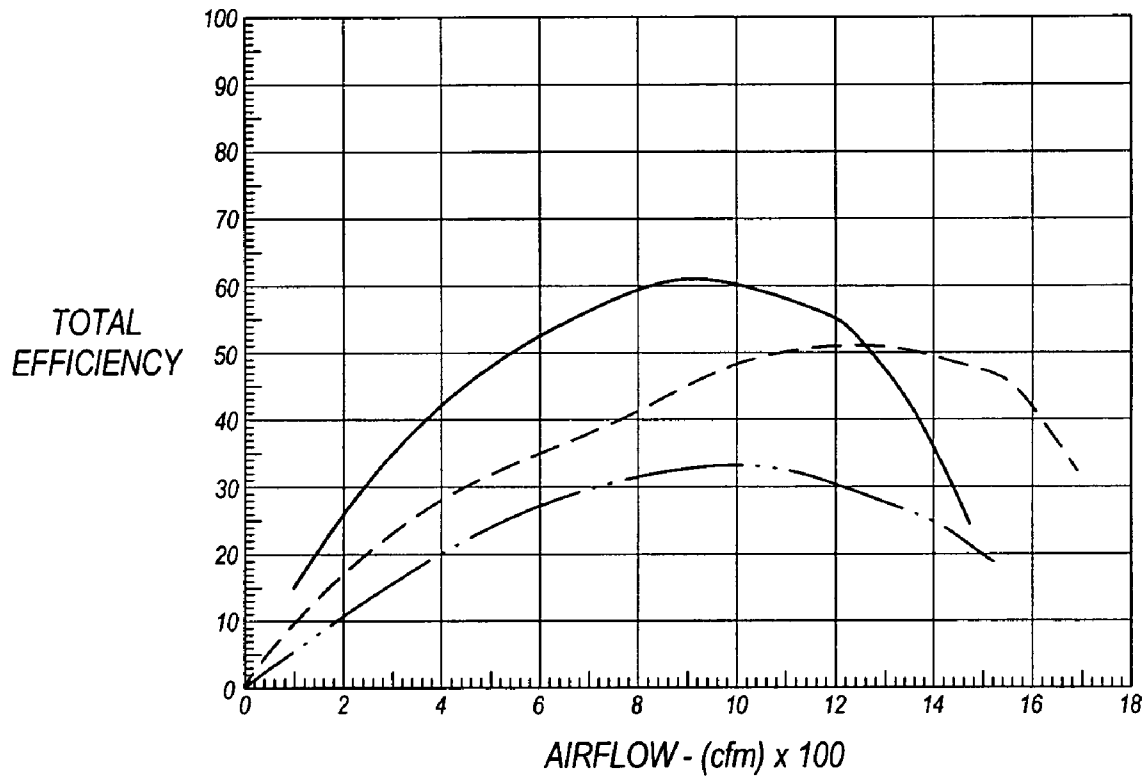

FIG. 10C

FAN ASSEMBLY AND METHOD

BACKGROUND OF THE INVENTION

[0001] Fans are used to generate air movement in a wide variety of applications, such as in heating, ventilating, and cooling systems. For example, a variety of axial-type fans (i.e., fans in which fluid is moved in a direction along the axis of rotation of the fan) are used in many industrial applications such as for ventilation purposes in office buildings, greenhouses, barns, factories, and other structures. Axial ventilation fans also have residential uses, such as in kitchens and bathrooms. As previously mentioned, axial fans are also commonly used in heating and cooling systems for heat transfer purposes. For example, axial fans are used for heat transfer purposes in a variety of applications, such as in air conditioning units, refrigeration units, computers, and in cars and other vehicles. In most of these applications, the fan is used to move air across a heat exchanger, wherein heat is transferred to the air as it passes by and/or through the heat exchanger.

[0002] Fan efficiency has become increasingly important, regardless of the type or application of the fan. Fan efficiency is typically important because fans are commonly driven by electric motors or other driving devices that consume valuable power. Inefficient fans consume more power, and are therefore less desirable than more efficient fans. Also, inefficient fans tend to require a different rotor geometry than efficient fans in order to meet the ventilation and heat transfer requirements of the systems in which the fans are used. For example, if a certain air flow is necessary for a system, an inefficient fan may have a greater number of blades, a greater diameter, and/or a larger motor than a more efficient fan. Therefore, inefficient fans can cost more than efficient fans in terms of materials and manufacturing expenses, and can occupy valuable system space. As such, fan manufacturers continue to search for ways to increase the efficiency of axial fans.

[0003] The marketplace, however, often places contradictory constraints upon fan manufacturers. For example, users of axial fans typically desire a relatively high fan efficiency, but also want fans that are compact and that generate the least noise possible. These constraints are often contradictory because many believe that fans generally need to be larger in order to reduce fan noise and/or airflow. Thus, in some cases, one demand can be met at the expense of another.

[0004] Axial fan efficiency is affected by a number of factors. For example, the efficiency of the motor or other device driving an axial fan can be an important factor in the overall efficiency of an axial fan and motor assembly. As another example, the speed of the fan motor and blades can impact fan efficiency. Increased fan motor and blade speed generally increases the amount of air turbulence moving through the fan—a result that is normally detrimental to fan efficiency. Turbulence is also a primary factor influencing the noise level of a fan.

[0005] The design and orientation of axial fan blades (e.g., axial fan blade shape, orientation with respect to the rest of the fan, and the like) are also factors in axial fan efficiency. It is generally recognized that certain shapes of fan blades are more efficient than others. For example, a machete or teardrop-shaped blade can often be more efficient than a cloverleaf-shaped blade.

[0006] The clearance between the blades of a fan and the fan housing can also impact axial fan efficiency. In many cases, this clearance is the distance between the tips of rotating blades and an adjacent fan housing wall. Blade-to-housing clearance is typically important because it often has a direct bearing upon the static pressure capabilities of the fan. For example, larger clearances between fan blade tips and adjacent housing walls can result in lower static pressure capabilities and lower fan efficiencies.

[0007] The design of an axial fan housing also impacts the efficiency of the axial fan. For example, the design of an fan housing air inlet can significantly influence efficiency of the axial fan by impacting the amount of turbulence within the fan. Turbulence within an axial fan can create a phenomenon known as vena contracta, which results in the reduction of the effective cross sectional area of the air inlet. Such a reduction permits less air to move through the air inlet, thereby reducing the efficiency of the axial fan.

[0008] Many of the efficiency factors discussed above are taken into account when designing conventional axial fans. However, still other efficiency factors can be important to axial fan performance, some of which are often not considered in conventional axial fan designs. Higher efficiency axial fans would be a welcome addition to the art.

SUMMARY OF THE INVENTION

[0009] Some embodiments of the present invention provide a fan assembly comprising a motor; a fan rotatably coupled to the motor for rotation about an axis and having a plurality of fan blades each having a leading edge with respect to a rotational direction of the fan blade and a trailing edge with respect to the rotational direction of the fan blade; and a shroud including a plurality of vanes extending transversely with respect to fluid flow through the fan assembly and through which fluid flows through the fan assembly, wherein the vanes are located downstream of the fan and oriented to extend away from a central area of the shroud, wherein each vane has a length defined between a radially inner end of the vane and a radially outer end of the vane, a leading edge, a trailing edge downstream of the leading edge of the vane with respect to fluid flow through the fan assembly, and a rearward swept angle defined between a first straight line extending through the radially inner and outer ends of the vane and a second straight line extending from the axis of the fan to the radially inner end of the vane, wherein the rearward swept angle is no less than about 5 degrees and is no greater than about 45 degrees, wherein each of the vanes is spaced from an adjacent vane by a gap measured from a first point on a first vane to a corresponding point on an adjacent vane, wherein each vane also has a chord length at the first point measured from the vane leading edge to the vane trailing edge, and wherein the fan assembly has a ratio of chord length to vane gap of no less than about 0.2 and no greater than about 3.5.

[0010] Also, some embodiments of the present invention provide a fan assembly comprising a motor; a fan rotatably coupled to the motor for rotation about an axis, wherein the fan has a plurality of fan blades each having a leading edge with respect to a rotational direction of the fan blade and a trailing edge with respect to the rotational direction of the fan blade; and a shroud including a plurality of vanes extending transversely with respect to fluid flow through the

fan assembly and through which fluid flows through the fan assembly, wherein the vanes are located downstream of the fan and oriented to extend away from a central area of the shroud, wherein each vane has a length defined between a radially inner end of the vane and a radially outer end of the vane, a leading edge, a trailing edge downstream of the leading edge of the vane with respect to fluid flow through the fan assembly, and an inlet angle defined between a straight line tangent to the vane at the leading edge of the vane and a plane orthogonal to the axis of the fan, wherein the straight line lies in a plane tangent to an imaginary cylinder centered at the axis of the fan, wherein the inlet angle is no less than about 20 degrees and is no greater than about 70 degrees, wherein each of the vanes is spaced from an adjacent vane by a gap measured from a first point on a first vane to a corresponding point on an adjacent vane, wherein each vane also has a chord length at the first point measured from the vane leading edge to the vane trailing edge, and wherein the fan assembly has a ratio of chord length to vane gap of no less than about 0.2 and no greater than about 3.5.

[0011] In some embodiments, a fan assembly is provided, and comprises a motor; a fan rotatably coupled to the motor for rotation about an axis, wherein the fan has a plurality of fan blades each having a leading edge with respect to a rotational direction of the fan blade and a trailing edge with respect to the rotational direction of the fan blade; and a shroud including a plurality of vanes extending transversely with respect to fluid flow through the fan assembly and through which fluid flows through the fan assembly, wherein the vanes are located downstream of the fan and oriented to extend away from a central area of the shroud, wherein each vane has a length defined between a radially inner end of the vane and a radially outer end of the vane, a leading edge, a trailing edge downstream of the leading edge of the vane with respect to fluid flow through the fan assembly, and an outlet angle defined between a straight line tangent to the vane at the trailing edge of the vane and a line parallel to the axis of the fan, wherein the straight line lies in a plane tangent to an imaginary cylinder centered at the axis of the fan, wherein the outlet angle is no less than about 30 degrees in a direction counter to rotation of the fan and is no greater than about 30 degrees in a rotational direction of the fan; wherein each of the vanes is spaced from an adjacent vane by a gap measured from a first point on a first vane to a corresponding point on an adjacent vane, wherein each vane also has a chord length at the first point measured from the vane leading edge to the vane trailing edge, and wherein the fan assembly has a ratio of chord length to vane gap of no less than about 0.2 and no greater than about 3.5.

[0012] Some embodiments of the present invention provide a fan assembly, comprising a motor; a fan rotatably coupled to the motor for rotation about an axis, wherein the fan has a plurality of fan blades each having a leading edge with respect to a rotational direction of the fan blade and a trailing edge with respect to the rotational direction of the fan blade; and a shroud including a plurality of vanes extending transversely with respect to fluid flow through the fan assembly and through which fluid flows through the fan assembly, wherein the vanes are located downstream of the fan and oriented to extend away from a central area of the shroud, wherein each vane has a length defined between a radially inner end of the vane and a radially outer end of the vane, a leading edge, and a trailing edge downstream of the

leading edge of the vane with respect to fluid flow through the fan assembly, wherein the shroud is separated from the fan by an axial gap between the leading edges of the vanes and the trailing edges of the fan blades, wherein the gap is no less than about 0.15 inches and no greater than about 1.5 inches, wherein each of the vanes is spaced from an adjacent vane by a gap measured from a first point on a first vane to a corresponding point on an adjacent vane, wherein each vane also having a chord length at the first point measured from the vane leading edge to the vane trailing edge, and wherein the fan assembly also has a ratio of chord length to vane gap of no less than about 0.2 and no greater than about 3.5.

[0013] In additional embodiments of the present invention, a fan assembly is provided, and comprises a motor; a fan rotatably coupled to the motor for rotation about an axis, wherein the fan has a plurality of fan blades each having a leading edge with respect to a rotational direction of the fan blade and a trailing edge with respect to the rotational direction of the fan blade; and a shroud including a plurality of vanes extending transversely with respect to fluid flow through the fan assembly and through which fluid flows through the fan assembly, wherein the vanes are located downstream of the fan and oriented to extend away from a central area of the shroud, wherein each vane has a leading edge and a trailing edge downstream of the leading edge with respect to fluid flow through the fan assembly, wherein each of the vanes is spaced from an adjacent vane by a gap measured from a first point on a first vane to a corresponding point on an adjacent vane, wherein each vane also has a chord length at the first point measured from the vane leading edge to the vane trailing edge, and wherein the fan assembly has a ratio of chord length to vane gap of no less than about 0.2 and no greater than about 2.5.

[0014] Further objects and advantages of the present invention, together with the organization and operation thereof, will become apparent from the following detailed description of the invention when taken in conjunction with the accompanying drawings, wherein like elements have like numerals throughout the drawings.

BRIEF DESCRIPTION OF THE DRAWINGS

[0015] The present invention is further described with reference to the accompanying drawings, which show an exemplary embodiment of the present invention. However, it should be noted that the invention as disclosed in the accompanying drawings is illustrated by way of example only. The various elements and combinations of elements described below and illustrated in the drawings can be arranged and organized differently to result in embodiments which are still within the spirit and scope of the present invention.

[0016] In the drawings, wherein like reference numeral indicate like parts:

[0017] **FIG. 1A** is a cross-sectioned elevational view of a fan assembly of the present invention, shown mounted near a heat exchanger;

[0018] **FIG. 1B** is a cross-sectioned elevational view of the fan assembly of the present invention illustrated in **FIG. 1A**, shown mounted in an alternate configuration;

[0019] **FIG. 2** is an exploded view of the fan assembly illustrated in **FIGS. 1A and 1B**;

[0020] FIG. 3 is a perspective view of the fan assembly illustrated in FIGS. 1A, 1B, and 2, shown partially sectioned;

[0021] FIG. 4 is a plan view of the fan assembly illustrated in FIGS. 1A, 1B, 2 and 3, viewed from the shroud side of the fan assembly;

[0022] FIG. 5 is a side cross-sectional view of the fan assembly illustrated in FIGS. 1-4, taken along lines 5—5 of FIG. 4;

[0023] FIG. 6 is a plan view of the fan assembly illustrated in FIGS. 1-5, viewed from the fan side of the assembly;

[0024] FIG. 7 is a detail cross-sectional side view of part of the fan assembly illustrated in FIGS. 1-6, taken along lines 7—7 of FIG. 4;

[0025] FIG. 8 is an enlarged view of the cross-sectioned elements illustrated in FIG. 7;

[0026] FIG. 9 is an end view of a fan blade from the fan assembly illustrated in FIGS. 1-8; and

[0027] FIGS. 10A-10C are performance curve comparison charts showing the performance of the fan assembly illustrated in FIGS. 1-9 compared to two conventional axial fans.

DETAILED DESCRIPTION OF EMBODIMENTS

[0028] An exemplary embodiment of an axial flow fan assembly 10 according to the present invention is illustrated in FIGS. 1-10. The exemplary fan assembly 10 in FIGS. 1-10 has a shroud 14, a motor 42 coupled to the shroud 14, and a fan 50 coupled to the motor 42. In operation, the motor 42 rotates a drive shaft 46 coupled to the fan 50. As the drive shaft 46 rotates, it powers the fan 50 to rotate within the shroud 14, and generates air movement. FIGS. 1A and 1B illustrate the fan in an exemplary environment. As illustrated, the fan is mounted to generate a stream of air to remove heat from condensing coils. This is just one of the many possible uses of this fan. Although a heat exchange environment is described herein and illustrated in FIGS. 1A and 1B, the fan of the present invention can be employed in any air moving application. Other uses known by those having ordinary skill in the art fall within the spirit and scope of the present invention.

[0029] As illustrated in FIGS. 2-6, the illustrated shroud 14 at least partially encloses fan blades 58 extending from a hub 54 of the fan 50. A portion of the shroud 14 has a generally circular wall 17 that extends around the radial periphery of the fan 50, although shrouds having any other wall shape can instead be employed as desired. The generally circular shaped wall 17 illustrated in FIGS. 2-6 (often referred to as a fan cylinder or fan ring) can have any diameter desired, depending at least in part upon the size of the fan employed. In some embodiments, the fan assembly has a nominal size between six inches and eighteen inches. However, other sized fans also fall within the spirit and scope of the present invention.

[0030] The fan shroud 14 in the illustrated exemplary embodiment has a set of mounting bosses 15 that can be employed to mount the fan assembly 10 to a frame, housing, or other structure. Any number of mounting bosses having

any shape can be employed, such as tab-shaped protrusions extending from the wall 17 of the shroud 14 as shown in the figures, lugs, posts, or fingers extending from the wall 17, a rib or flange extending partially or fully around the wall 17, and the like. Such mounting elements or features can be secured to a frame, housing, or other structure by bolts, screws, nails, rivets, pins, or other conventional fasteners, by clamps, clips, inter-engaging or snap-fit fingers or other features, and the like.

[0031] In some embodiments, the same fan assembly 10 can be mounted in different orientations as needed in different applications. For example, it may be desirable to mount the fan assembly 10 in one orientation in order to pull air through a condenser or other device, while in another application it may be desirable to mount the fan in a reversed direction to blow air into a condenser or other device. This mounting versatility is provided in some embodiments by the use of two different shrouds 14, each of which has mounting elements or features (described above) located at different axial positions on the shroud 14. In the illustrated embodiment for example, one shroud 14 has mounting bosses 15 located at a downstream end of the fan assembly 10 (see FIG. 1A), while another shroud 14' has mounting bosses 15' located at an upstream end of the fan assembly 10 (see FIG. 1B). In this manner, a shroud 14, 14' can be selected that will enable at least the majority of the fan assembly 10 to be recessed within the structure to which it is mounted.

[0032] In other embodiments, the mounting elements or features of the shroud 14 can be located in any axial position along the shroud 14. By way of example only, mounting bosses 15 can be located at an axial mid-point between the ends of the shroud 14, thereby permitting the fan assembly 10 to be mounted in both orientations described above without the need for two different shrouds and while still keeping a substantial portion of the fan assembly 10 recessed within the structure to which it is mounted in both orientations. Regardless of the axial location of the mounting elements or features employed on the shroud 14, the fan assembly 10 can still be mounted in two opposite orientations (although the ability to recess a majority or the entirety of the fan assembly 10 in both orientations may be limited).

[0033] The mounting elements or features 15 of the shroud 14 described above can be integral with the shroud 14. However, in other embodiments these mounting elements or features 15 are attached to the shroud 14 in any suitable manner, such as by a ring (not shown) encircling the shroud 14 and that can be secured with respect to the shroud 14 in a number of different axial positions. As another example, the mounting elements or features 15 can be attached to the shroud 14 at different axial locations by screws, bolts, nails, rivets, pins, or other conventional fasteners, inter-engaging elements, adhesive or cohesive bonding material, and the like.

[0034] The size of the fan ring 17 with respect to the fan 50 can have an impact on the efficiency of the fan assembly 10. As will be described in greater detail below, the efficiency of the fan assembly 10 can increase as the spacing between the fan 50 and the fan ring 17 decreases. Thus, in some embodiments of the present invention, the fan ring 17 generally has an inside diameter nearly matching the outside diameter of the fan 50. More specifically, in some embodi-

ments good performance results are achieved by using a fan ring 17 having an inside diameter providing a non-contacting clearance fit with the fan blades 58 or a clearance not exceeding 0.125 inches. A clearance between the fan blades 58 and the fan ring 17 of no greater than 0.08 can provide better performance results. Also, a clearance between the fan blades 58 and the fan ring 17 not exceeding 0.05 inches can provide still better performance results.

[0035] As seen in FIG. 3, the fan cylinder 17 can have a double wall. Although a single-walled fan cylinder 17 can be employed, a double wall fan cylinder can reduce vibration generated by operation of the fan assembly 10.

[0036] The shroud 14 in the illustrated exemplary embodiment has a plurality of vanes 18 directly or indirectly attached to the fan cylinder 17 at one end of the fan cylinder 17. Although the vanes 18 can be integral with the fan cylinder 17 as shown in FIGS. 2-5, in other embodiments the vanes 18 are not integral with the cylinder 17, and can be attached to the cylinder in any conventional manner. Furthermore, even though the vanes 18 of the illustrated embodiment are located at one end or at the edge of the cylinder 17, the vanes 18 do not necessarily need to be located at an end or edge of the cylinder 17. For example, depending upon the shape and length of the fan cylinder 17, the vanes 18 could be located in different axial positions along the fan cylinder 17. The plurality of vanes 18 can serve several functions. For example, the vanes 18 can do one or more of the following: help to increase performance of the fan assembly 10, alter the direction of air movement through the fan assembly 10, and/or act as a safety device (to limit or prevent access to the fan 50 through the shroud 14). As shown in the illustrated embodiment, the vanes 18 can extend in generally radial directions from the fan cylinder 17 towards the center of the shroud 14. The vanes 18, however, do not necessarily have to extend directly radially. Rather, in alternative embodiments, the vanes 18 can have any orientation with respect to the shroud 14, including but not limited to orientations in which the vanes 18 are parallel to radial lines extending from an axis of rotation of the fan 50, orientations in which the vanes are at an angle with respect to such radial lines (e.g., wherein the radially innermost portion of each vane 18 is located in front of or behind the radially outermost portion of each vane 18 in the circumferential direction), orientations in which imaginary lines drawn through the length of the vanes 18 intersect an axis of rotation of the fan 50, orientations in which such imaginary lines do not intersect the axis of rotation of the fan 50, and the like.

[0037] The vanes 18 of the shroud 14 can be arranged on the shroud 14 in any desired manner. By way of example only, the vanes 18 can be equally spaced from one another, can be arranged in any pattern desired (i.e., repeating or non-repeating pattern), or can be randomly spaced. In the illustrated exemplary embodiment, the vanes 18 extend in a generally radial direction and are also angled with respect to the direction of fan rotation. More specifically, the radially innermost end of each vane 18 illustrated in the figures is located circumferentially ahead of the radially outermost end of the vane 18 (with reference to the direction of rotation of the fan 50). As explained above, the vanes 18 can instead be oriented in an opposite direction, in which case the radially innermost end of each vane 18 is located circumferentially behind the radially outermost end of the vane 18.

[0038] If employed, vanes 18 can be located on all or any portion of the shroud 14, including the fan cylinder 17. As shown in the illustrated embodiment, vanes 18 cover the majority of the shroud 14 surface perpendicular to the axis of rotation of the fan 50. However, as illustrated, the vanes 18 extend only partially between the fan cylinder 17 and the center of the fan cylinder 17. In the illustrated embodiment of the present invention, vanes 18 extend across the same general area in front of the fan 50 (downstream of the fan 50) as the fan blades 58. The remainder of the center portion of the shroud 14, as seen in FIGS. 2 and 3, can serve to house the motor 42 as shown in the figures. Therefore, in some embodiments of the present invention, vanes 18 are not included in this area of the shroud 14. However, in some embodiments, vanes 18 can be placed in this area, depending at least in part upon the axial position of the motor 42 with respect to the shroud 14.

[0039] Regardless of the number and orientation of the vanes 18, the vanes 18 can take any cross-sectional shape desired. For example, each vane 18 can be flat, triangular, U-shaped, can have a generally airfoil shape, can present a concave or convex shape toward or away from the direction of rotation of the blades 58 and/or in either direction along the axis of rotation of the fan 50, and the like. Furthermore, the vanes 18 can be cambered between the vane leading edges 30 and vane trailing edges 34 and/or can be twisted along the length of the vanes (in a clockwise or counterclockwise direction viewed along the length of the blade from tip to root), or the like. As best illustrated in FIG. 8, vanes 18 of the illustrated embodiments have a cambered, generally airfoil-like cross-section, wherein the concave portion of the cambered vanes 18 faces the leading edge of the blades 58. In addition, the vanes 18 can have any shape desired along the length of the vanes 18. In the illustrated embodiment, the vanes 18 are substantially straight along the length of the vanes 18. However, in other embodiments for example, the vanes 18 can be bowed in either direction with respect to the direction of rotation of the fan 50.

[0040] In some embodiments of the present invention, the orientation of the leading and trailing edges of the vanes can significantly influence the performance of the fan assembly 10. With reference to FIG. 8, the orientation of the leading edge 30 of each vane 18 can be defined at least in part by an angle D between a plane orthogonal to the axis of rotation of the fan assembly 10 and a line tangent to the surface of the vane 18 facing (or at least partially facing) the fan blades 58 at the leading edge 30 of the vane 18. As discussed herein, the shape and/or orientation of the vanes 18 can change along the lengths of the vanes 18. Accordingly, in some embodiments, this leading edge or "inlet" angle D is measured at a mid-point along the lengths of the vanes 18, or at ($\frac{1}{2}R$) or ($\frac{2}{3}R$) in other embodiments (where R is the radius of the fan assembly 10 at the outer limits of the vanes 18).

[0041] In some embodiments, this leading edge or "inlet" angle D of the vanes 18 is at least 20° and/or is no greater than 70°. Better performance results can be achieved by employing an angle D that is at least 30° and/or is no greater than 60°. Still better performance can be achieved by employing an angle D that is at least 45° and/or is no greater than 55°. These ranges are generally applicable to fans having a nominal size from about six inches to about eighteen inches, although such vane inlet angles D can be employed in fan assemblies having any diameter. Depending

upon other parameters on the fan assembly **10**, such as the type and characteristics of the fluid being moved, the normal operational speed (or anticipated ranges of speeds) of the fan assembly **10**, and the like, the vane inlet angle D can vary.

[0042] In some embodiments of the present invention, the vane inlet angles (or ranges of vane inlet angles) described above are employed alone or in combination with other characteristics of the fan assembly **10** described herein to generate superior fan performance. With continued reference to **FIG. 8**, the orientation of the trailing edge **34** of each vane **18** can be defined at least in part by an angle E between a plane parallel to and passing through the axis of rotation of the fan assembly **10** and a line tangent to the surface of the vane **18** facing (or at least partially facing) the fan blades **58** at the trailing edge **34** of the vane **18**. As discussed herein, the shape and/or orientation of the vanes **18** can change along the lengths of the vanes **18**. Accordingly, in some embodiments, this trailing edge or “outlet” angle E is measured at a mid-point along the lengths of the vanes **18**, or at ($\frac{1}{2}R$) or ($\frac{2}{3}R$) in other embodiments (where R is the radius of the fan assembly **10** at the outer limits of the vanes **18**).

[0043] In some embodiments, this trailing edge or “outlet” angle E of the vanes **18** is at least -30° and/or is no greater than 30° (wherein a negative angle refers to an angle in a direction opposite the direction of rotation of the fan **50** as viewed in **FIG. 8**, and wherein a positive angle refers to an angle in the direction of rotation of the fan **50** as also viewed in **FIG. 8**). However, an angle E of at least -10° and/or no greater than 20° can provide better performance results. Also, an angle E of at least -5° and/or no greater than 10° can provide still better fan performance. These ranges are generally applicable to fans having a nominal size from about six inches to about eighteen inches, although such vane outlet angles E can be employed in fan assemblies having any diameter. Depending upon other parameters on the fan assembly **10**, such as the type and characteristics of the fluid being moved, the normal operational speed (or anticipated ranges of speeds) of the fan assembly **10**, and the like, the vane outlet angle E can vary.

[0044] In some embodiments of the present invention, the vane outlet angles (or ranges of vane outlet angles) described above are employed alone or in combination with other characteristics of the fan assembly **10** described herein to generate superior fan performance.

[0045] In some embodiments of the present invention, selected rearwardly-swept angles or ranges of angles of the vanes **18** (when viewed along the axis of rotation of the fan assembly **10**) are employed alone or in combination with other characteristics of the fan assembly **10** described herein to generate superior fan performance. A vane **18** is said to be rearwardly-swept when a radially outermost end of the vane **18** is located circumferentially behind a radially innermost end with reference to the direction of rotation of the fan **50**. A rearwardly-swept vane **18** can be defined by an angle between a line extending along the leading or trailing edge **34, 30** of the vane **18** and a straight line extending from the axis of rotation of the fan assembly **10** through a radially innermost point on the vane **18**. In other embodiments (such as those embodiments in which the vane **18** is not straight along the length of the vane **18**), the amount which a vane **18** is rearwardly-swept can be defined by an angle between

the chord of the vane **18** (or, if no chord can be readily identified, a straight line extending through the radially innermost and outermost points of the vane **18**) and a straight line extending from the axis of rotation of the fan assembly **10** through the radially innermost point of the vane **18**. All measurements of the angle defining the rearward sweep of the vane **18** (referenced herein and in the appended claims) are made with reference to a plan view of the fan assembly **10** such as that shown in **FIGS. 4 and 6**.

[0046] In some embodiments of the present invention, this rearward sweep angle of the vanes **18** is no less than 5° and/or is no greater than 45° . However, better performance results can be achieved by employing a rearward sweep angle that is less than 10° and/or is no greater than 35° . Also, a rearward sweep angle that is less than 10° and/or is no greater than 25° can produce still better fan performance. These ranges are generally applicable to fans having a nominal size from about six inches to about eighteen inches. However, these ranges are not limited to fans of such size. Depending upon other parameters on the fan assembly **10**, such as the type and characteristics of the fluid being moved, the normal operational speed (or anticipated ranges of speeds) of the fan **50**, and the like, this angle can vary.

[0047] As illustrated in **FIGS. 2-6**, the vanned area of the shroud **14** can be split into two radial areas—one area for radially outer vanes **22** and the other area for radially inner vanes **26**. In some embodiments, dividing the vanned area into two areas **22, 26** can improve performance of the fan assembly **10** and/or can provide greater structural strength to the shroud **14**. Since pressure gradients can occur across the length of the fan blades **58**, in some cases the performance of the fan assembly **10** can be improved by selecting the number of vanes **18** in both the outer **22** and inner **26** vane areas based upon desired operational characteristics of the fan assembly **10** (e.g., fan speed, fan power, and the like). For example, in the illustrated embodiment, thirty-seven outer vanes **22** and twenty-one inner vanes **26** are used to achieve good fan performance under certain conditions. However, in various other operating conditions (i.e., for different fan speeds and diameters, when moving different fluids having different properties, for fans having different fan blade shapes, and the like), the number of vane areas and the vane count within those areas can be altered as desired. For example, in some embodiments, the inner vanes **26** and the outer vanes **22** are integral. In other words, the outer vanes **22** can extend all the way to the central hub (if employed). Additionally, in yet other embodiments, the inner vanes can be omitted, leaving a ring-shaped gap between a motor housing wall **53** (if employed) of the shroud **14** and the outermost tier of vanes **22**, in which case struts or other structural members can secure the motor housing wall **53** to the rest of the shroud **14**. Furthermore, in some embodiments, additional tiers of vanes can be employed (i.e., inner, outer, and middle; first, second, third, etc.).

[0048] The vanes located in various tiers need not necessarily have the same characteristics as vanes located in other tiers. For example, the inner vanes **26** in the illustrated embodiment can have the same or different cross-sectional shapes as the outer vanes **22**, and can have any shape described above. By way of example only, the inner vanes **26** in the illustrated embodiment can have a first shape, while the outer vanes **22** can have a second shape different

from the first. Additionally, the different tiers of vanes can be oriented in any manner described above. Thus, the inner vanes **26** can have first orientation, while the outer vanes **22** can have a second orientation different than the first.

[0049] In some embodiments, the number of vanes in each tier can be the same. However, in other embodiments, the number of vanes in each tier can be different. In some embodiments, the blade-to-vane count is about 10:50 (e.g., in some 11-inch diameter fans according to the present invention). However, regardless of the number of vane areas or tiers employed (i.e., the number of areas of the shroud **14** having different sets of vanes **18**), it is desirable in some embodiments to employ a number of vanes that is not a multiple of the blade count. When the vane count is a multiple of the blade count, harmonics can be more likely to develop, causing pressure problems within the fan **50** and resulting performance reductions of the fan assembly **10**. For example, if the fan **50** were to have a blade count of ten blades **58**, then in some embodiments none of the vane areas (if there is more than one) would have a vane count equal to a multiple of ten, such as twenty, thirty, forty, fifty, sixty, etc. In some embodiments, the blade-to-vane count is about 10:65 (e.g., in some 12-inch diameter fans according to the present invention).

[0050] In some embodiments of the present invention, superior performance results can be obtained by employing a particular shroud solidity or by employing any shroud solidity within a range of shroud solidities. In such embodiments, selected shroud solidities (or ranges of shroud solidities) are employed alone or in combination with other characteristics of the fan assembly **10** described herein to generate superior fan performance. Shroud solidity is a characteristic of the overall fan assembly **10** that can be selected to change the efficiency of the fan assembly **10**. Referring to FIGS. 7 and 8, the solidity of the shroud is the ratio of a vane's chord length (indicated as "A") to the gap (indicated as "B") measured between the same point on two adjacent vanes. For example, in the illustrated embodiment, the measurement for shroud solidity is made from the midpoint of the trailing edge **34** of a first vane **18** to the midpoint of the trailing edge **34** of an adjacent vane **18**. In other embodiments, this measurement can be made at the leading edges **30** of the vanes **18** or anywhere between the leading and trailing edges **30**, **34** of the vanes **18**. Note, however, that since the vanes **18** can be arranged in a radial fashion, the gap between vanes **18** can vary along the radial length of the vanes **18**. Thus, the measurement of shroud solidity as described above can vary along the vanes **18**. The chord length is measured along a line from the leading edge **30** to the trailing edge **34** of the vane.

[0051] With continued reference to the measurement of shroud solidity described above, in some embodiments, the chord length of the vanes **18** is variable along the length of the vane from root to tip. Thus, the chord length of the vanes **18** used to measure shroud solidity is measured at the same location used to measure the gap between adjacent vanes **18** as described above (both measurements being made at the same location anywhere along the length of the vanes **18**). In the illustrated embodiment, for example, the gap and chord length measurements of the vanes **18** are taken at the same point: at the midpoint of the outer vanes **22**. In other words, the either or both measurements can be taken at a radial mid-point in the outer two-thirds of the fan assembly

10. As discussed above, either or both measurements can be taken elsewhere in other embodiments, such as anywhere along the outer vanes **22** in the illustrated exemplary embodiment, at a location half way between the axis of rotation and the radially outermost ends of the vanes **18**, at a location half way between the radially innermost and radially outermost ends of the vanes **18**, and the like.

[0052] The solidity of the shroud **14** in some embodiments of the present invention is at least 0.2 and/or is no greater than 3.5 (e.g., measured at the vane trailing edges and at a midpoint along the vanes of the shroud, such as at the midpoint of the outer vanes **22** in the illustrated embodiment).

[0053] However, a shroud solidity of at least 0.5 and/or no greater than 2.5 can produce better performance results. Also, still better performance results can be achieved by employing a shroud solidity of at least 1.0 and/or no greater than 2.0. These ranges are generally applicable to fans having a nominal size from about six inches to about eighteen inches. However, these ranges are not limited to fans of such size. In still other embodiments of the present invention, the above-described solidity ranges are different, often depending at least in part upon other parameters on the fan assembly **10**, such as the number of blades **58** of the fan **50**, the distance of the fan **50** from the shroud **14**, the normal operational speed (or anticipated ranges of speeds) of the fan **50**, and the like.

[0054] As shown in the illustrated exemplary embodiment, a motor **42** is used to power the fan assembly **10**. The motor **42** of the fan assembly **10** can be any conventional motor **42**, such as an AC or DC electric motor (by way of example only, a permanent split capacitor AC induction motor or a brushless DC motor). Some embodiments of the present invention utilize a high efficiency motor **42** to help reduce overall system inefficiencies. In some embodiments such as that shown in the figures, the motor **42** has a motor housing **38** secured to the shroud **14**. The motor **42** can instead be attached to the shroud **14** by one or more brackets connected to the motor **42** and shroud **14**, by mounting lugs on the motor **42** and/or shroud **14**, and the like. In the illustrated exemplary embodiment, the motor housing **38** is attached to the shroud **14** through the use of conventional fasteners, such as screws, nuts and bolts, pins or other conventional fasteners, by snap fit connections, adhesive or cohesive bonding material, press fits, and the like.

[0055] With continued reference to the illustrated embodiment, the motor **42** mounted on the shroud **14** has a drive shaft **46** that extends through the motor housing **38** to drive the fan **50**. As shown in FIGS. 3 and 5, the drive shaft **46** of the motor **42** can be attached to a hub **54** of the fan **50**. This attachment can be any conventional type of attachment, such as a keyed connection, a press or interference fit, a splined connection, or any other male/female connection (whether or not secured by a set screw, pin, or other such element), a coupling connection, and the like. In those embodiments of the present invention in which the fan **50** employs a hub **54**, a plurality of fan blades **58** can be attached at the hub's periphery (or can be integral to the hub **54**) and can extend radially outward therefrom. In other embodiments, the fan blades **58** extend out from any other rotating central element to which the fan blades **58** are attached or with which the fan blades **58** are integral. Thus,

rotation of the motor 42 causes the drive shaft 46 to rotate, which in turn causes the central hub 54 to rotate (if employed) and causes the plurality of fan blades 58 to rotate.

[0056] In the illustrated embodiment of the present invention, the hub 54 has a first face 55 that extends in a generally radial direction and which is generally perpendicular to the drive shaft 46. This first face 55 can be circular in shape with the drive shaft coupling to this face substantially at the center of the circle. In other embodiments, the portion to which the drive shaft 46 couples can have any shape desired, including without limitation a first face 55 that is concave or convex in the direction away from the fan assembly 10 (e.g., whether having a rounded profile in either direction, a profile defined by planar surfaces joined at angles with respect to one another, and the like). In other embodiments, the forward end of the hub 54 is pointed or otherwise protrudes along the axis of rotation of the fan assembly 10. Other hub shapes 54 can be employed in still other embodiments of the present invention. With reference back to the illustrated exemplary embodiment, a second face 56 of the illustrated hub 54 extends from the periphery of the first face 55 towards the shroud 17, and can be joined directly to the first face 55 or can be joined thereto by a curved or angled intermediate surface as shown in the figures. In the illustrated embodiment, this second face 56 wraps around and partially encloses a portion of the motor housing 38. As illustrated, the hub 54 in cooperation with the shroud 14 can substantially enclose the motor housing 38. In some embodiments, the motor 42 can be entirely enclosed or encased by the hub 54 and shroud 17 with the exception of a gap sufficient (or only sufficient) to provide rotational clearance between the hub 54 and shroud 14.

[0057] The blades 58 of the fan 50 can be attached to or integral with the hub 54 along the second surface 56 as shown in the figures. In other embodiments, the blades extend from other portions of the hub determined at least in part upon the shape of the hub 54 employed. Each blade 58 has a root 62 and a tip 66. The blades 58 are coupled to or are integral with the hub 54 at the root 62, with the remainder of the blade 58 extending at least radially therefrom to the tip 66. The blades 58 can have any shape desired, such as a cloverleaf, machete, or teardrop shape by way of example only. In addition, the shape of the blades 58 can change along their length (from root 62 to tip 66). By way of example only, the shape of each blade 58 illustrated in the figures tapers from root 62 to tip 66. This tapered blade 58 can provide significant performance enhancements to the fan assembly 10 of the present invention. In other embodiments, non-tapered blades 58 can instead be employed.

[0058] The blades 58 can have any cross-sectional shape desired, including without limitation rectangular, flat, triangular, irregular, and other cross-sectional shapes. In the illustrated embodiment for example, the fan blades 58 each have a generally airfoil-shaped cross-section as best shown in FIG. 7. Referring to FIG. 7, the thicker portion of the illustrated airfoil (including the thick edge) is generally referred to as the leading edge 70 of the blade 58 because during normal rotation of the fan 50 it is rotationally ahead of the remainder of the blade 58. Conversely, the thinner portion of the blade (including the thin edge) is generally referred to as the trailing edge 74 because during normal rotation of the fan 50 it is rotationally behind the remainder of the blade 58. However, determination of the leading edge

70 and trailing edge 74 for a blade 58 is dependent upon the direction of rotation of the fan 50. Therefore, note that in the description which follows, terms such as “forward,” “backward,” “leading” and “trailing” are all with respect to the direction of rotation of the fan assembly 10 indicated in FIG. 6. It is apparent that if the fan 50 were to rotate in the opposite direction, then these terms would be reversed (i.e., “forward” would become “backward” and “leading” would become “trailing”).

[0059] Referring to FIGS. 7 and 9, it is shown that the leading edge 70 of each blade 58 is displaced axially with respect to the trailing edge 74. This is sometimes referred to as the pitch angle of the blade 58 or the angle of attack. With reference to the direction of airflow through the fan assembly 10 (in a generally axial direction) past the vanes 18 and blades 58, the leading edge 70 of each blade 58 is located upstream of the trailing edge 74, or is angled below a horizontal line drawn at the trailing edge 74 of the blade 58 in FIG. 7 (wherein the blade 58 rotates to the left in FIG. 7 in normal operation). Although each blade 58 can instead be angled such that the leading edge 70 is instead located downstream of the trailing edge 74, or such that the leading and trailing edges 70, 74 are at the same axial location in the fan assembly 10, good performance results are achieved by the blades in which the leading edge 70 of each blade 58 is located upstream of the trailing edge 74. A pitch angle of at least 10 degrees and/or no greater than 35 degrees at a midpoint along the length of each blade 58 can provide good performance results. However, a pitch angle of at least 12 degrees and/or no greater than 30 degrees at a midpoint along the length of each blade 58 can provide better performance results. Also, a pitch angle of at least 15 degrees and/or no greater than 23 degrees at a midpoint along the length of each blade 58 can provide still better performance results.

[0060] In some embodiments of the present invention, it is the angle of blade pitch that helps determine the amount of airflow and the pressure differential across the airfoil. In some embodiments, the pitch angle of each blade 58 varies radially. Stated another way, each blade's angle of attack is different at the root 62 than it is at the tip 66. This characteristic can be referred to as blade twist. In some embodiments of the present invention, selected blade twist angles (or ranges of blade twist angles) are employed alone or in combination with other characteristics of the fan assembly 10 described herein to generate superior fan performance. FIG. 9 illustrates blade twist and a convenient method of measuring the blade twist angle. To measure the blade twist angle as illustrated, a chord is drawn along the tip 66 of the blade 58 from the trailing edge 74 to the leading edge 70. Then, a second chord is drawn at the root 62 of the blade 58 from the trailing edge 74 to the leading edge 70. The angle between the two chords is the blade twist angle. Any (or no) amount of blade twist can be employed in the present invention. In some embodiments, a blade twist angle falling between 0° and 45° can be employed for good performance results. However, a blade twist angle falling between 5° and 25° can be employed for better fan performance. Also, a blade twist angle falling between 8° and 18° can be employed for still better fan performance. Depending upon other parameters on the fan assembly 10, such as the type and characteristics of the fluid being moved, the normal operational speed (or anticipated ranges of speeds) of the fan 50, and the like, the blade twist angle can vary.

[0061] In some embodiments of the present invention, the fan blades 58 extend radially toward positions immediately adjacent the fan cylinder 17 of the shroud 14, wherein clearance exists (and in some cases, only sufficient clearance exists) for rotation of the fan blades 58 with respect to the shroud 14. The position of the fan blades 58 with regard to the shroud 14 can have an effect on the efficiency and performance of the fan assembly 10. For example, the clearance between the tips 66 of the blades 58 and the inside wall of the fan cylinder 17 as just described can be an important parameter relating to the efficiency and performance of the fan assembly 10. If close tip clearance is not maintained, leakage can occur between the fan blade tips 66 and the shroud 14 because air will take the path of least resistance through the fan assembly 10, thereby generating reduced performance in regard to pressure capabilities and airflow.

[0062] In some embodiments of the present invention, another parameter that can influence performance of the fan assembly 10 is the spacing between the vanes 18 on the shroud 14 and the blades 58 of the fan 50. In those embodiments in which the portions of the fan blades 58 and vanes 18 closest to one another are the trailing edges 74 of the fan blades 58 and the leading edges 30 of the vanes 18 (as discussed above), this spacing is measured between the trailing edges 74 of the fan blades 58 and the leading edges 30 of the vanes 18. However, in other embodiments in which the pitch of the fan blades 58 is different and/or in which the orientation of the vanes 18 is different, this spacing is measured between the closest portions of the fan blades 58 and vanes 18. In some embodiments of the present invention, selected vane-to-blade spacings (or ranges of vane-to-shroud spacings) are employed alone or in combination with other characteristics of the fan assembly 10 described herein to generate superior fan performance. With reference to the illustrated exemplary embodiment, FIGS. 7 and 8 provide a cross-sectional view of the proximity of the fan blades 58 to the vanes 18 on the shroud 14. In some embodiments, the gap between the trailing edges 74 of the fan blades 58 and the leading edges 30 of the vanes 18, as indicated by the letter C, is at least 0.15 inches and/or is no greater than 1.5 inches. However, this gap can be at least 0.2 inches and/or no greater than 1.0 inches for better performance results. Also, this gap can be at least 0.25 inches and/or no greater than 0.5 inches for still better fan performance. These ranges are generally applicable to fans having a nominal size from about six inches to about eighteen inches, although such gaps can be employed in fan assemblies having any diameter. Depending upon other parameters on the fan assembly 10, such as the type and characteristics of the fluid being moved, the normal operational speed (or anticipated ranges of speeds) of the fan 50, and the like, the gap between the fan blades 58 and the vanes 18 can vary.

[0063] In some embodiments of the present invention, significant performance improvements are achieved over conventional fan assemblies when one or more of the fan assembly characteristics is employed as discussed above. By way of example only, the performance of the illustrated fan assembly 10 having a nominal diameter of twelve inches is illustrated in FIGS. 10A-10C and compared to two conventional twelve inch fans. The fan assembly 10 illustrated in the figures has a blade twist angle of approximately 11°, a solidity ratio of approximately 1.5 (measured at a mid-point along the lengths of the outer vanes 22), a gap between blade

trailing edges 74 and vane leading edges of approximately 0.38 inches, a vane inlet angle D of approximately 51° (measured at a mid-point along the lengths of the outer vanes 22), a vane outlet angle E of approximately 4° (measured at a mid-point along the lengths of the outer vanes 22), a leading edge rearwardly-swept angle of approximately 16° and a blade pitch angle of approximately 19° (measured at a mid-point along the lengths of the outer vanes 22). The first conventional fan used to create the comparison in FIGS. 10A-10C is a twelve inch fan currently available in the marketplace. This fan is labeled as Prior Art Fan No. 1 on FIGS. 10A-10C. The second conventional fan used in the comparison is another twelve inch fan currently available in the marketplace. This fan is labeled as Prior Art Fan No. 2 on FIGS. 10A-10C.

[0064] The characteristic curve plots in FIGS. 10A-10C illustrate the total efficiency, the brake horsepower, and the static pressure of each fan assembly against air flow. These numbers were obtained experimentally by measuring and calculating the parameters at various air flows amounts.

[0065] The embodiments described above and illustrated in the figures are presented by way of example only and are not intended as a limitation upon the concepts and principles of the present invention. As such, it will be appreciated by one having ordinary skill in the art that various changes in the elements and their configuration and arrangement are possible without departing from the spirit and scope of the present invention. For example, one or more of the above mentioned embodiments can be applied to an axial fan individually or in combination to increase the efficiency of the fan as desired.

What is claimed is:

1. A fan assembly, comprising:

a motor;

a fan rotatably coupled to the motor for rotation about an axis, the fan having a plurality of fan blades, each fan blade having a leading edge with respect to a rotational direction of the fan blade and a trailing edge with respect to the rotational direction of the fan blade; and

a shroud including a plurality of vanes extending transversely with respect to fluid flow through the fan assembly and through which fluid flows through the fan assembly, the vanes being located downstream of the fan and oriented to extend away from a central area of the shroud; each vane having:

a length defined between a radially inner end of the vane and a radially outer end of the vane;

a leading edge;

a trailing edge downstream of the leading edge of the vane with respect to fluid flow through the fan assembly; and

a rearward swept angle defined between a first straight line extending through the radially inner and outer ends of the vane and a second straight line extending from the axis of the fan to the radially inner end of the vane, wherein the rearward swept angle is no less than about 5 degrees and is no greater than about 45 degrees;

wherein each of the vanes is spaced from an adjacent vane by a gap measured from a first point on a first vane to a corresponding point on an adjacent vane, each vane also having a chord length at the first point measured from the vane leading edge to the vane trailing edge, the fan assembly having a ratio of chord length to vane gap of no less than about 0.2 and no greater than about 3.5.

2. The fan assembly as claimed in claim 1, wherein the ratio of chord length to vane gap is no less than about 0.5 and is no greater than about 2.5.

3. The fan assembly as claimed in claim 1, wherein the ratio of chord length to vane gap is no less than about 1.0 and is no greater than about 2.0.

4. The fan assembly as claimed in claim 1, wherein the rearward swept angle is no less than about 10 degrees and is no greater than about 35 degrees.

5. The fan assembly as claimed in claim 2, wherein the rearward swept angle is no less than about 10 degrees and is no greater than about 35 degrees.

6. The fan assembly as claimed in claim 3, wherein the rearward swept angle is no less than about 10 degrees and is no greater than about 35 degrees.

7. The fan assembly as claimed in claim 1, wherein the rearward swept angle is no less than about 10 degrees and is no greater than about 25 degrees.

8. The fan assembly as claimed in claim 2, wherein the rearward swept angle is no less than about 10 degrees and is no greater than about 25 degrees.

9. The fan assembly as claimed in claim 3, wherein the rearward swept angle is no less than about 10 degrees and is no greater than about 25 degrees.

10. The fan assembly as claimed in claim 1, wherein:

each vane has an inlet angle defined between a straight line tangent to the vane at the leading edge of the vane and a plane orthogonal to the axis of rotation of the fan;

the straight line lies in a plane tangent to an imaginary cylinder centered at the axis of the fan; and

the inlet angle is no less than about 20 degrees and is no greater than about 70 degrees.

11. The fan assembly as claimed in claim 10, wherein the inlet angle is no less than about 30 degrees and is no greater than about 60 degrees.

12. The fan assembly as claimed in claim 10, wherein the inlet angle is no less than about 45 degrees and is no greater than about 55 degrees.

13. The fan assembly as claimed in claim 1, wherein:

each vane has an outlet angle defined between a straight line tangent to the vane at the trailing edge of the vane and a line parallel to the axis of the fan;

the straight line lies in a plane tangent to an imaginary cylinder centered at the axis of the fan; and

the outlet angle is no less than about 30 degrees in a direction counter to rotation of the fan and is no greater than about 30 degrees in a rotational direction of the fan.

14. The fan assembly as claimed in claim 13, wherein the outlet angle is no less than about 10 degrees in a direction counter to rotation of the fan and is no greater than about 20 degrees in a rotational direction of the fan.

15. The fan assembly as claimed in claim 13, wherein the outlet angle is no less than about 5 degrees in a direction counter to rotation of the fan and is no greater than about 10 degrees in a rotational direction of the fan.

16. The fan assembly as claimed in claim 1, wherein the fan is separated from the shroud by an axial gap between the leading edges of the vanes and the trailing edges of the fan blades, the gap being no less than about 0.15 inches and no greater than about 1.5 inches.

17. The fan assembly as claimed in claim 16, wherein the gap is no less than about 0.20 inches and is no greater than about 1.0 inches.

18. The fan assembly as claimed in claim 16, wherein the gap is no less than about 0.25 inches and is no greater than about 0.5 inches.

19. The fan assembly as claimed in claim 1, wherein:

each fan blade has a blade root and a blade tip;

each fan blade has a twisted shape along a length of the fan blade from the blade root to the blade tip, the twisted shape defining a twist angle of the blade; and

the blade twist angle is no greater than about 45 degrees.

20. The fan assembly as claimed in claim 19, wherein the blade twist angle is no less than about 5 degrees and is no greater than about 25 degrees.

21. The fan assembly as claimed in claim 19, wherein the blade twist angle is no less than about 8 degrees and is no greater than about 18 degrees.

22. The fan assembly as claimed in claim 1, wherein:

each blade has a pitch angle with respect to a plane orthogonal to the axis of the fan; and

the pitch angle is no less than about 10 degrees and is no greater than about 35 degrees.

23. The fan assembly as claimed in claim 22, wherein the pitch angle is no less than about 12 degrees and is no greater than about 30 degrees.

24. The fan assembly as claimed in claim 22, wherein the pitch angle is no less than about 15 degrees and is no greater than about 23 degrees.

25. The fan assembly as claimed in claim 1, wherein each of the vanes has an airfoil shaped cross section.

26. The fan assembly as claimed in claim 1, wherein each of the vanes has a cambered surface defining a curved shape extending from the leading edge of the vane to the trailing edge of the vane.

27. A fan assembly, comprising:

a motor;

a fan rotatably coupled to the motor for rotation about an axis, the fan having a plurality of fan blades, each fan blade having a leading edge with respect to a rotational direction of the fan blade and a trailing edge with respect to the rotational direction of the fan blade; and

a shroud including a plurality of vanes extending transversely with respect to fluid flow through the fan assembly and through which fluid flows through the fan assembly, the vanes being located downstream of the fan and oriented to extend away from a central area of the shroud; each vane having:

a length defined between a radially inner end of the vane and a radially outer end of the vane;

a leading edge;

a trailing edge downstream of the leading edge of the vane with respect to fluid flow through the fan assembly; and

an inlet angle defined between a straight line tangent to the vane at the leading edge of the vane and a plane orthogonal to the axis of the fan, wherein the straight line lies in a plane tangent to an imaginary cylinder centered at the axis of the fan, the inlet angle being no less than about 20 degrees and is no greater than about 70 degrees;

wherein each of the vanes is spaced from an adjacent vane by a gap measured from a first point on a first vane to a corresponding point on an adjacent vane, each vane also having a chord length at the first point measured from the vane leading edge to the vane trailing edge, the fan assembly having a ratio of chord length to vane gap of no less than about 0.2 and no greater than about 3.5.

28. The fan assembly as claimed in claim 27, wherein the ratio of chord length to vane gap is no less than about 0.5 and is no greater than about 2.5.

29. The fan assembly as claimed in claim 27, wherein the ratio of chord length to vane gap is no less than about 1.0 and is no greater than about 2.0.

30. The fan assembly as claimed in claim 27, wherein the inlet angle is no less than about 30 degrees and is no greater than about 60 degrees.

31. The fan assembly as claimed in claim 28, wherein the inlet angle is no less than about 30 degrees and is no greater than about 60 degrees.

32. The fan assembly as claimed in claim 29, wherein the inlet angle is no less than about 30 degrees and is no greater than about 60 degrees.

33. The fan assembly as claimed in claim 27, wherein the inlet angle is no less than about 45 degrees and is no greater than about 55 degrees.

34. The fan assembly as claimed in claim 28, wherein the inlet angle is no less than about 45 degrees and is no greater than about 55 degrees.

35. The fan assembly as claimed in claim 29, wherein the inlet angle is no less than about 45 degrees and is no greater than about 55 degrees.

36. The fan assembly as claimed in claim 27, wherein:

each vane has an outlet angle defined between a straight line tangent to the vane at the trailing edge of the vane and a line parallel to the axis of the fan;

the straight line lies in a plane tangent to an imaginary cylinder centered at the axis of the fan; and

the outlet angle is no less than about 30 degrees in a direction counter to rotation of the fan and is no greater than about 30 degrees in a rotational direction of the fan.

37. The fan assembly as claimed in claim 36, wherein the outlet angle is no less than about 10 degrees in a direction counter to rotation of the fan and is no greater than about 20 degrees in a rotational direction of the fan.

38. The fan assembly as claimed in claim 36, wherein the outlet angle is no less than about 5 degrees in a direction counter to rotation of the fan and is no greater than about 10 degrees in a rotational direction of the fan.

39. The fan assembly as claimed in claim 27, wherein the fan is separated from the shroud by an axial gap between the leading edges of the vanes and the trailing edges of the fan blades, the gap being no less than about 0.15 inches and no greater than about 1.5 inches.

40. The fan assembly as claimed in claim 39, wherein the gap is no less than about 0.20 inches and is no greater than about 1.0 inches.

41. The fan assembly as claimed in claim 39, wherein the gap is no less than about 0.25 inches and is no greater than about 0.5 inches.

42. The fan assembly as claimed in claim 27, wherein:

each fan blade has a blade root and a blade tip;

each fan blade has a twisted shape along a length of the fan blade from the blade root to the blade tip, the twisted shape defining a twist angle of the blade; and

the blade twist angle is no greater than about 45 degrees.

43. The fan assembly as claimed in claim 42, wherein the blade twist angle is no less than about 5 degrees and is no greater than about 25 degrees.

44. The fan assembly as claimed in claim 42, wherein the blade twist angle is no less than about 8 degrees and is no greater than about 18 degrees.

45. The fan assembly as claimed in claim 27, wherein:

each blade has a pitch angle with respect to a plane orthogonal to the axis of the fan; and

the pitch angle is no less than about 10 degrees and is no greater than about 35 degrees.

46. The fan assembly as claimed in claim 45, wherein the pitch angle is no less than about 12 degrees and is no greater than about 30 degrees.

47. The fan assembly as claimed in claim 45, wherein the pitch angle is no less than about 15 degrees and is no greater than about 23 degrees.

48. The fan assembly as claimed in claim 27, wherein each of the vanes has an airfoil shaped cross section.

49. The fan assembly as claimed in claim 27, wherein each of the vanes has a cambered surface defining a curved shape extending from the leading edge of the vane to the trailing edge of the vane.

50. A fan assembly, comprising:

a motor;

a fan rotatably coupled to the motor for rotation about an axis, the fan having a plurality of fan blades, each fan blade having a leading edge with respect to a rotational direction of the fan blade and a trailing edge with respect to the rotational direction of the fan blade; and

a shroud including a plurality of vanes extending transversely with respect to fluid flow through the fan assembly and through which fluid flows through the fan assembly, the vanes being located downstream of the fan and oriented to extend away from a central area of the shroud; each vane having:

a length defined between a radially inner end of the vane and a radially

outer end of the vane;

a leading edge;

a trailing edge downstream of the leading edge of the vane with respect to fluid flow through the fan assembly; and

an outlet angle defined between a straight line tangent to the vane at the trailing edge of the vane and a line parallel to the axis of the fan, wherein the straight line lies in a plane tangent to an imaginary cylinder centered at the axis of the fan; the outlet angle being no less than about 30 degrees in a direction counter to rotation of the fan and is no greater than about 30 degrees in a rotational direction of the fan;

wherein each of the vanes is spaced from an adjacent vane by a gap measured from a first point on a first vane to a corresponding point on an adjacent vane, each vane also having a chord length at the first point measured from the vane leading edge to the vane trailing edge, the fan assembly having a ratio of chord length to vane gap of no less than about 0.2 and no greater than about 3.5.

51. The fan assembly as claimed in claim 50, wherein the ratio of chord length to vane gap is no less than about 0.5 and is no greater than about 2.5.

52. The fan assembly as claimed in claim 50, wherein the ratio of chord length to vane gap is no less than about 1.0 and is no greater than about 2.0.

53. The fan assembly as claimed in claim 50, wherein the outlet angle is no less than about 10 degrees in a direction counter to rotation of the fan and is no greater than about 20 degrees in a rotational direction of the fan.

54. The fan assembly as claimed in claim 51, wherein the outlet angle is no less than about 10 degrees in a direction counter to rotation of the fan and is no greater than about 20 degrees in a rotational direction of the fan.

55. The fan assembly as claimed in claim 52, wherein the outlet angle is no less than about 10 degrees in a direction counter to rotation of the fan and is no greater than about 20 degrees in a rotational direction of the fan.

56. The fan assembly as claimed in claim 50, wherein the outlet angle is no less than about 5 degrees in a direction counter to rotation of the fan and is no greater than about 10 degrees in a rotational direction of the fan.

57. The fan assembly as claimed in claim 51, wherein the outlet angle is no less than about 5 degrees in a direction counter to rotation of the fan and is no greater than about 10 degrees in a rotational direction of the fan.

58. The fan assembly as claimed in claim 52, wherein the outlet angle is no less than about 5 degrees in a direction counter to rotation of the fan and is no greater than about 10 degrees in a rotational direction of the fan.

59. The fan assembly as claimed in claim 50, wherein the fan is separated from the shroud by an axial gap between the leading edges of the vanes and the trailing edges of the fan blades, the gap being no less than about 0.15 inches and no greater than about 1.5 inches.

60. The fan assembly as claimed in claim 59, wherein the gap is no less than about 0.20 inches and is no greater than about 1.0 inches.

61. The fan assembly as claimed in claim 59, wherein the gap is no less than about 0.25 inches and is no greater than about 0.5 inches.

62. The fan assembly as claimed in claim 50, wherein:

each fan blade has a blade root and a blade tip;

each fan blade has a twisted shape along a length of the fan blade from the blade root to the blade tip, the twisted shape defining a twist angle of the blade; and

the blade twist angle is no greater than about 45 degrees.

63. The fan assembly as claimed in claim 62, wherein the blade twist angle is no less than about 5 degrees and is no greater than about 25 degrees.

64. The fan assembly as claimed in claim 62, wherein the blade twist angle is no less than about 8 degrees and is no greater than about 18 degrees.

65. The fan assembly as claimed in claim 50, wherein:

each blade has a pitch angle with respect to a plane orthogonal to the axis of the fan; and

the pitch angle is no less than about 10 degrees and is no greater than about 35 degrees.

66. The fan assembly as claimed in claim 65, wherein the pitch angle is no less than about 12 degrees and is no greater than about 30 degrees.

67. The fan assembly as claimed in claim 65, wherein the pitch angle is no less than about 15 degrees and is no greater than about 23 degrees.

68. The fan assembly as claimed in claim 50, wherein each of the vanes has an airfoil shaped cross section.

69. The fan assembly as claimed in claim 50, wherein each of the vanes has a cambered surface defining a curved shape extending from the leading edge of the vane to the trailing edge of the vane.

70. A fan assembly, comprising:

a motor;

a fan rotatably coupled to the motor for rotation about an axis, the fan having a plurality of fan blades, each fan blade having a leading edge with respect to a rotational direction of the fan blade and a trailing edge with respect to the rotational direction of the fan blade; and

a shroud including a plurality of vanes extending transversely with respect to fluid flow through the fan assembly and through which fluid flows through the fan assembly, the vanes being located downstream of the fan and oriented to extend away from a central area of the shroud; each vane having:

a length defined between a radially inner end of the vane and a radially outer end of the vane;

a leading edge; and

a trailing edge downstream of the leading edge of the vane with respect to fluid flow through the fan assembly, wherein the shroud is separated from the fan by an axial gap between the leading edges of the vanes and the trailing edges of the fan blades, the gap being no less than about 0.15 inches and no greater than about 1.5 inches;

wherein each of the vanes is spaced from an adjacent vane by a gap measured from a first point on a first vane to a corresponding point on an adjacent vane, each vane also having a chord length at the first point measured from the vane leading edge to the vane trailing edge, the fan assembly having a ratio of

chord length to vane gap of no less than about 0.2 and no greater than about 3.5.

71. The fan assembly as claimed in claim 70, wherein the ratio of chord length to vane gap is no less than about 0.5 and is no greater than about 2.5.

72. The fan assembly as claimed in claim 70, wherein the ratio of chord length to vane gap is no less than about 1.0 and is no greater than about 2.0.

73. The fan assembly as claimed in claim 70, wherein the gap is no less than about 0.20 inches and is no greater than about 1.0 inches.

74. The fan assembly as claimed in claim 71, wherein the gap is no less than about 0.20 inches and is no greater than about 1.0 inches.

75. The fan assembly as claimed in claim 72, wherein the gap is no less than about 0.20 inches and is no greater than about 1.0 inches.

76. The fan assembly as claimed in claim 70, wherein the gap is no less than about 0.25 inches and is no greater than about 0.5 inches.

77. The fan assembly as claimed in claim 71, wherein the gap is no less than about 0.25 inches and is no greater than about 0.5 inches.

78. The fan assembly as claimed in claim 72, wherein the gap is no less than about 0.25 inches and is no greater than about 0.5 inches.

79. A fan assembly, comprising:

a motor;

a fan rotatably coupled to the motor for rotation about an axis, the fan having a plurality of fan blades, each fan blade having a leading edge with respect to a rotational direction of the fan blade and a trailing edge with respect to the rotational direction of the fan blade; and

a shroud including a plurality of vanes extending transversely with respect to fluid flow through the fan assembly and through which fluid flows through the fan assembly, the vanes being located downstream of the fan and oriented to extend away from a central area of the shroud, each vane having a leading edge and a trailing edge downstream of the leading edge with respect to fluid flow through the fan assembly, each of the vanes spaced from an adjacent vane by a gap measured from a first point on a first vane to a corresponding point on an adjacent vane, each vane also having a chord length at the first point measured from the vane leading edge to the vane trailing edge, the fan assembly having a ratio of chord length to vane gap of no less than about 0.2 and no greater than about 2.5.

80. The fan assembly as claimed in claim 79, wherein the ratio of chord length to vane gap is no less than about 0.5 and is no greater than about 2.5.

81. The fan assembly as claimed in claim 79, wherein the ratio of chord length to vane gap is no less than about 1.0 and is no greater than about 2.0.

* * * * *