

(19)
(12)

(KR)
(A)

(51) 。 Int. Cl.7
H01L 29/78

(11)
(43)

2003-0091533
2003 12 03

(21) 10-2002-0029614
(22) 2002 05 28

(71) 3 416

(72) 8-39403

(74)

:

(54) /

· ,
/ , /

8

1 8

(21) (11) 1 (25) .
 2 (29a) (27a) 2 (29a) .
 2 (29a) (21) 가 가 (29)가 .
 , (21) (21) (11) / (33) . /
 (33) / (33) .
 1 8 .
 1 , (11), (21) (21) (21) . (13) (21)
 , (13), (15,17) (15,17) (19) . (17), (13) ,
 (19) .
 , (21) LDD(lightly doped drain) (ion implantation)
 (11) (23) .
 (23) . (11) P N .
 2 , (21) (11) 1 1 (25) . 1
 (25) (11) (21) , 1 (25) (21)
 , (11) .
 (21) 1 (25) (11) (27) 1 (27)
 1 (25) 1 (25) .
 3 , 1 (25) 1 (27)가 2 (29)
 . 2 (29) (step coverage)가 가
 (21) (21) 3 가 .
 4 , (wet etch) 2 1
 (29) (21) (21) (11) 2 (29) 1
 2 (29)가 가 . (25)
 2 (29) 가 .
 5 , 1 (27)가 (11) .
 2 (29) 2 (21) (31)가 1 2 (27) (11)
 . 2 (31) .
 6 , 2 (31) 2 2 (29)
 2 (29a) , 2 (31) (29)
 (21) 가 (21) 가 가 가 가 가 가 . 2 (29a)
 (21) 가 2 (29a) 가 가 (21) .
 . 2 (29a) .
 7 , (21) 1 (27) 2
 (31) , 2 (31) 1
 (27) .
 , 2 (29a) (21) (11)

/ (33) , 2 (29a) 가 (21) 가
/ (33) / (33)

8 , 2 (29a) (21) 3 (35)

(57)

1.

;

/ ,

2.

1
가 ,

3.

1 , 가

4.

;

1 ;

1 1 ;

2

1 ;

1 1 2 ;

2 2 ; 가

2 ;

2 ;

2 / ;

2 3

- 4 n) 5. , LDD(lightly doped drai
- 4 6. , 1 , 2
- 1 가 2 (Wet etch) 2
- 4 7. , 2
- 4 8. , 2
- 4 9. , 2 1

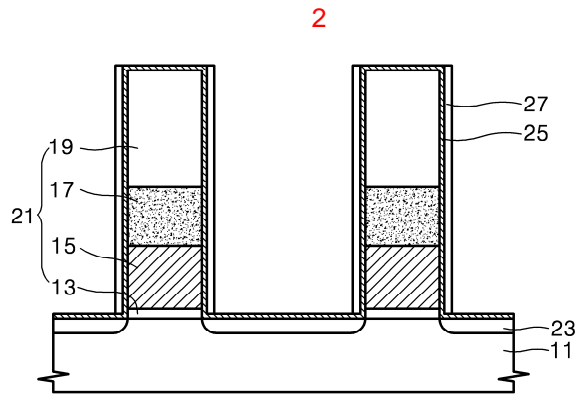
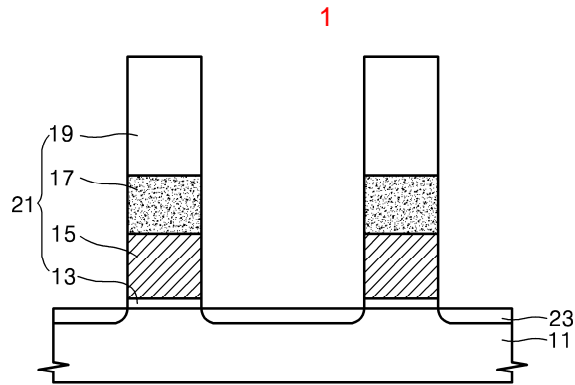

3

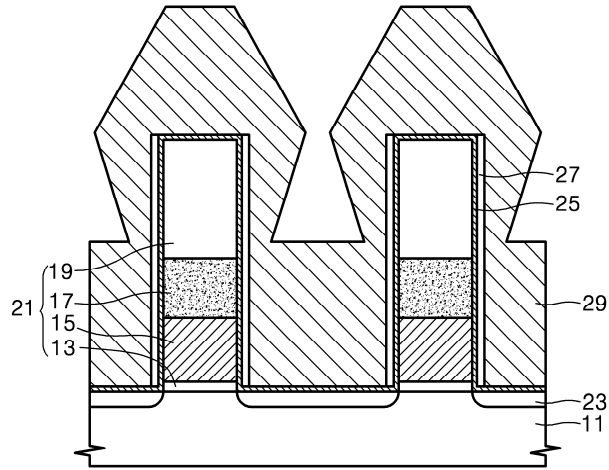

4

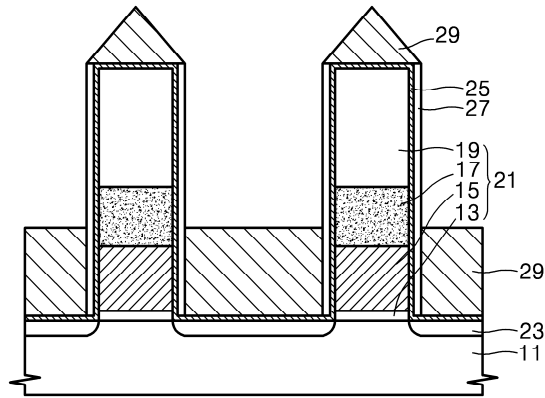

5

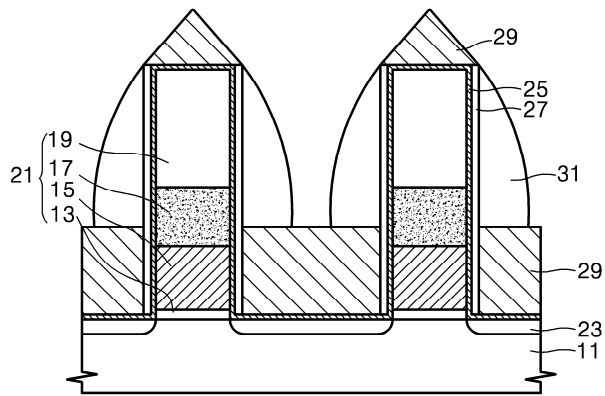

6

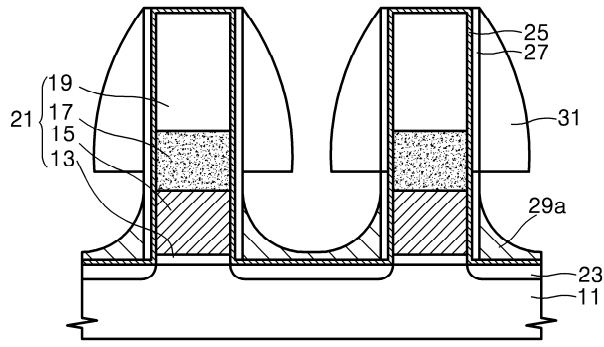

7

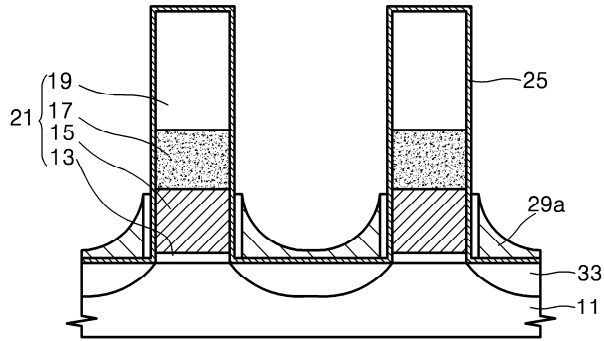

8

