



US00D823770S

(12) **United States Design Patent** (10) **Patent No.:** **US D823,770 S**  
**Koenigs** (45) **Date of Patent:** **\*\* Jul. 24, 2018**

(54) **VEHICLE WHEEL** D682,763 S \* 5/2013 Song ..... D12/211  
D683,294 S 5/2013 Pollmann  
(71) Applicant: **Bayerische Motoren Werke** D715,210 S \* 10/2014 Wolff ..... D12/211  
**Aktiengesellschaft, Munich (DE)** D723,996 S \* 3/2015 Zhao ..... D12/211  
D735,106 S \* 7/2015 Weil ..... D12/209  
(72) Inventor: **Daniel Koenigs, Munich (DE)** D751,015 S \* 3/2016 Mahoney ..... D12/209  
D777,639 S \* 1/2017 Krause ..... D12/209  
(73) Assignee: **Bayerische Motoren Werke** D788,004 S \* 5/2017 Mielke ..... D12/209  
**Aktiengesellschaft, Munich (DE)** D791,056 S \* 7/2017 Valencia Pollex ..... D12/211  
D798,788 S \* 10/2017 Valencia Pollex ..... D12/211  
D806,632 S \* 1/2018 Peat ..... D12/211

(\*\*) Term: **15 Years**

**FOREIGN PATENT DOCUMENTS**

(21) Appl. No.: **29/590,499**

EM 000934468-0003 10/2009  
EM 001693599-0003 6/2011  
EM 001812504-0001 8/2012  
EM 002120279-0002 9/2013

(22) Filed: **Jan. 11, 2017**

(30) **Foreign Application Priority Data**

\* cited by examiner

Jul. 12, 2016 (DE) ..... 40 2016 100 875

*Primary Examiner* — Sheryl Lane

(51) **LOC (11) Cl.** ..... **12-16**

*Assistant Examiner* — Calvin E Vansant

(52) **U.S. Cl.** ..... **D12/209**

(74) *Attorney, Agent, or Firm* — Crowell & Moring LLP

(58) **Field of Classification Search**

(57) **CLAIM**

USPC ..... D12/204–213; D21/563  
CPC .... B60B 7/00; B60B 7/02; B60B 7/04; B60B  
7/06; B60B 3/02; B60B 3/04; B60B 3/06;  
B60B 3/10; B60B 1/00; B60B 1/08;  
B60B 1/10; B60B 1/12  
See application file for complete search history.

The ornamental design for a vehicle wheel, as shown and described.

**DESCRIPTION**

(56) **References Cited**

**U.S. PATENT DOCUMENTS**

D585,354 S 1/2009 Powell et al.  
D593,022 S \* 5/2009 Forster ..... D12/211  
D628,136 S \* 11/2010 Leclercq ..... D12/211  
D629,346 S 12/2010 Szews  
D639,224 S \* 6/2011 Szews ..... D12/211  
D658,560 S 5/2012 Thurner  
D666,953 S \* 9/2012 Pollmann ..... D12/209

FIG. 1 is a perspective view of a vehicle wheel according to the design;  
FIG. 2 is an additional perspective view thereof;  
FIG. 3 is an additional perspective view thereof;  
FIG. 4 is a front view thereof;  
FIG. 5 is a rear view thereof; and,  
FIG. 6 is a side view thereof.  
The low contrast or “ghost” areas shown in FIG. 5 of the drawings depict portions of the vehicle wheel that form no part of the claim.

**1 Claim, 6 Drawing Sheets**

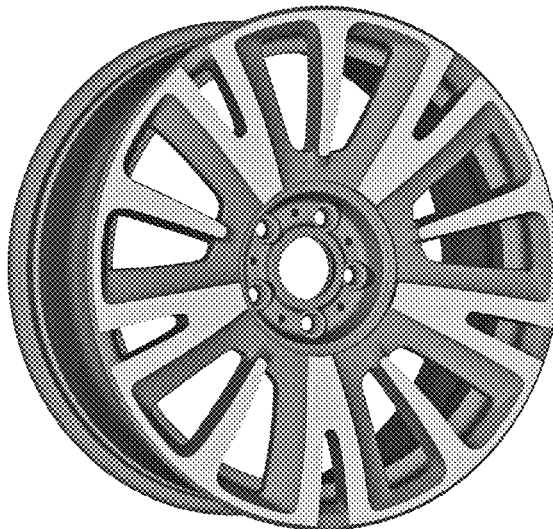



Fig. 1



Fig. 2



Fig. 3



Fig. 4

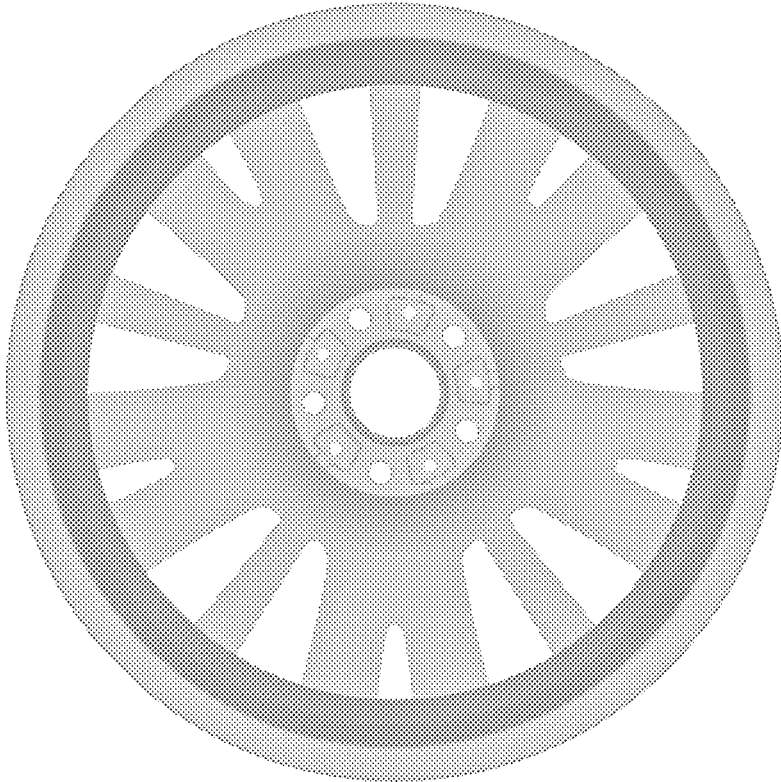

Fig. 5

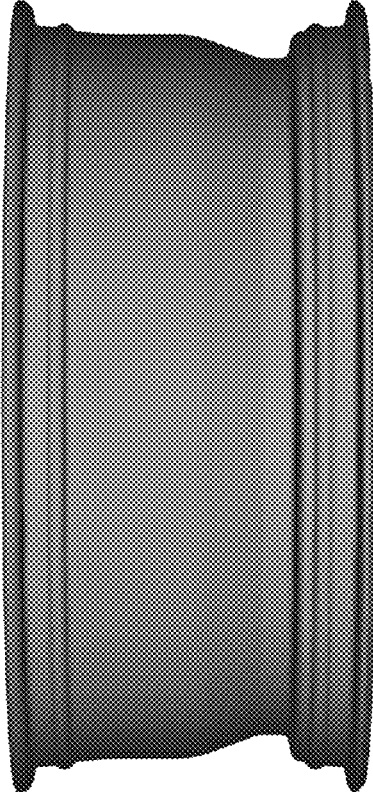

Fig. 6