

Jan. 27, 1953

M. B. GWINN ET AL
COMBINED TIE HANGER AND COVER

2,626,735

Filed April 14, 1949

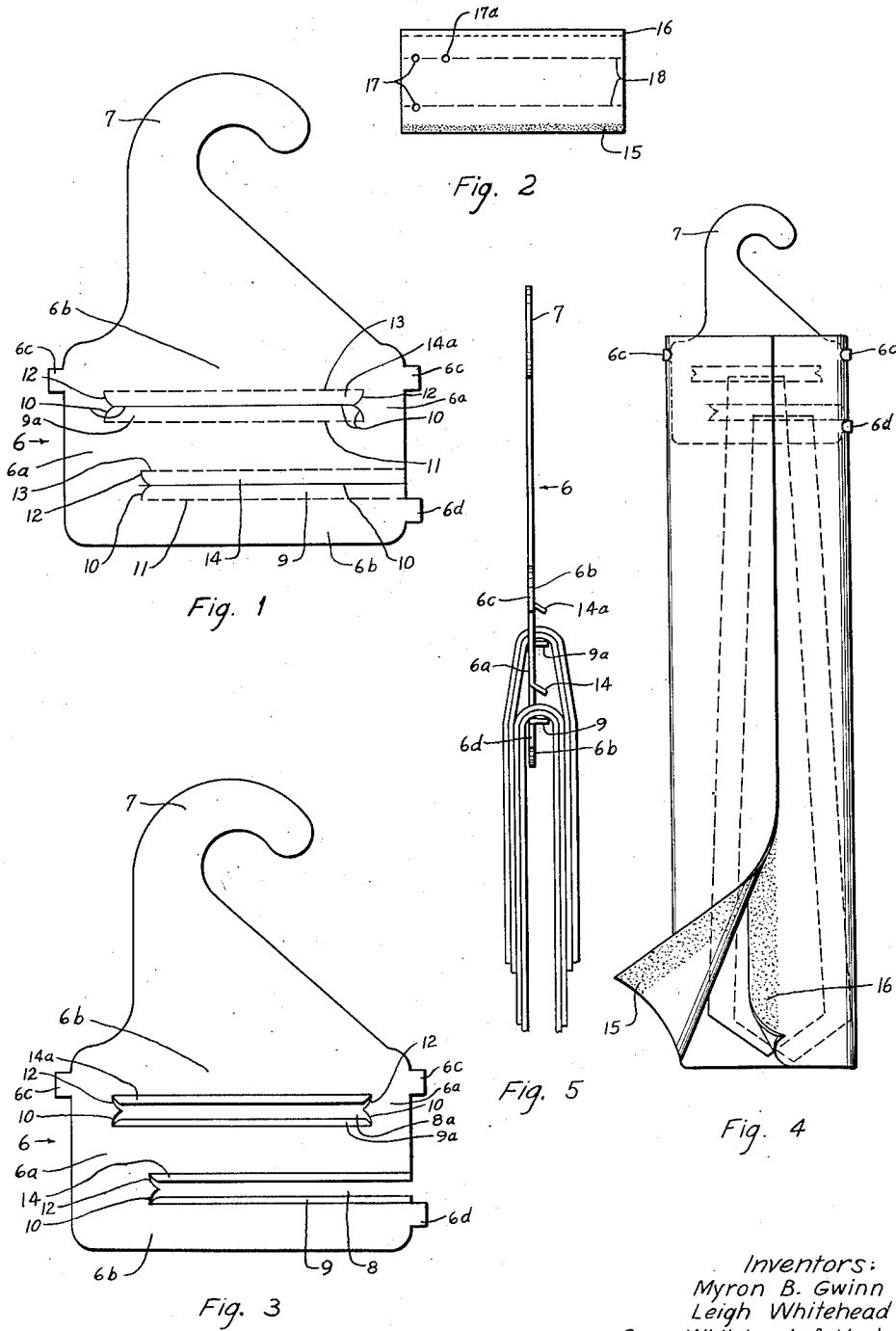

Inventors:
Myron B. Gwinn
Leigh Whitehead
By Whitehead & Vogl
Per: *Earle Whitehead*
Attorneys.

UNITED STATES PATENT OFFICE

2,626,735

COMBINED TIE HANGER AND COVER

Myron B. Gwinn and Leigh Whitehead, Denver,
 Colo.; said Whitehead assignor to said Gwinn

Application April 14, 1949, Serial No. 87,506

2 Claims. (Cl. 223-98)

1

This invention relates to apparel hanging and protecting devices and especially to a combined hanger for neckties and a covering for the hung ties, adapted for use by dry cleaners, laundries and the like.

An object of the invention is to provide a combination device of the class described which will provide for hanging ties without creasing them and at the same time provide a cover to protect the cleaned ties.

A further object is to provide a combined hanger and protector, of the class described, which can be furnished the user and/or stored in large quantities in the minimum of space, which shall be so cheap that the user can, without more than nominal expense, provide such a combined hanger and protector with each tie or lot of ties cleaned and which can be applied to the ties with a minimum of time and labor.

With the foregoing and other objects in view, all of which shall more fully hereinafter appear, the invention comprises certain novel constructions, arrangements and combinations of parts as shall now be described and as defined in the appended claims and as illustrated, in preferred embodiment, in the accompanying drawing, in which:

Figure 1 is a broadside elevation of the hanger element of the invention in form ready for shipment or storage.

Figure 2 is a plan, on greatly reduced scale, of the covering or protecting element of the invention in form for shipment, storage or ready for use.

Figure 3 is a view the same as Fig. 1 except that the bars and flaps are illustrated as bent outwardly from the body of the hanger in form ready for hanging the ties thereon.

Figure 4 is a front elevation of the combined hanger and protecting element, in completed assembly with the ties hung and enclosed therein, the enclosed ties being indicated principally in broken lines and part in full lines.

Figure 5 is an edge elevation of the hanger with four ties hung thereon, ready for enclosure in the protection element, the ties being shown fragmentarily.

The invention comprises the hanger and the cover, originally formed separately but coordinated in structure so as to form a unitary hanger and cover device when assembled.

The hanger, illustrated at Fig. 1 in its original form, prior to use or assembly, is made of cardboard or any other sheet material having similar qualities of cheapness and sufficient of both

2

rigidity and pliability for the intended use as herein described. It has a body 6 of length suitable to accommodate the ties and leave a margin portion 6a sufficient to provide substantial support for the ties, and a height sufficient to provide for one or more slots and hanging bars, as later described, and leave a top and bottom portion 6b sufficient to provide the required strength and rigidity, depending on the qualities of the cardboard or other material used. A suspending hook 7 is provided, being preferably cut, from the material used, integral with the body 6.

A slot 8 and hanging bar 9 are provided by cutting through the cardboard along the lines indicated at 10 and scoring the cardboard along line 11 so that the bar 9 may be manually bent outwardly, along line 11, to form the bar 9 in position clearly illustrated at Fig. 5, leaving the slot 8 open with bar 9 projecting outwardly along the lower edge of the slot. For convenience in bending outwardly the bar 9, the cardboard may also be cut along lines 12 and scored along lines 13, thus providing a flap 14 along the upper edge of the slot. This flap also serves the purpose, when bent outwardly, of stiffening the body and also rounds the upper edge of the slot which would, otherwise, be a sharp edge and without reinforcement.

The cover element of the invention, illustrated at Fig. 2, comprises a sheet of paper or other similarly cheap, thin and pliable material having a length preferably longer than that of a tie when folded over a hanger in the usual manner, and a width which is double the length of the body 6 of the hanger plus the width of a coated portion along one margin, as later explained, and a slight excess to allow for the thickness of the ties to be enclosed.

This cover element is coated along its margins with pressure sensitive adhesive of that quality which will not adhere to plain surfaces, such as paper, but will adhere, under pressure, to a surface coated with the same adhesive. This adhesive is applied to the top surface of one margin of the cover element as at 15 and to the under surface of the opposite margin as at 16, so that, while the cover sheets are in stacks, neither strip of adhesive will adhere to the plain paper surface of the next adjacent cover sheet, but when the cover sheet is folded around the body 6 of the hanger the coated margins 15 and 16 will overlap with their coated surfaces in mutual contact, as illustrated at Fig. 4, in which position said coated strips will, when subjected to slight pressure, adhere to each other and form a protective casing

3

around the body 6 and the ties hanging therefrom. The hanger element 6 has lugs 6c and 6d projecting from its ends and the cover has eyes 17 and 17a which engage lugs 6c and 6d respectively when the cover is folded around the hanger, thus preventing the cover dropping from the hanger, the eye 17a also serving as a supplementary support for the free end of bottom portion 6b of the hanger through its engagement with lug 6d.

The cover may be scored along the dotted lines 18 to facilitate the correct folding of the cover.

The hanger is preferably formed with one or more additional slots and bars 8a and 9a and flaps 14a for the accommodation of ties in excess of those which can suitably be accommodated in slot 8 over bar 9. The additional slot, bar and flap or slots, bars and flaps are preferably inset to approximately the center of the body of the hanger, as clearly illustrated at Figs. 1, 3 and 4, thus affording more strength and rigidity than if all slots were cut through the margin as in slot 8.

The operation is as follows: The operator will take a hanger element from stock and manually force the bar 9 and, in the illustrated embodiment, flap 14 outwardly to the positions shown at Fig. 5, whereupon the ties may be slid into slot 8 through the open end thereof as seen at the right at Figs. 1 and 3. If there are additional ties the operator will force the end of a tie against the upper edge of bar 9a, namely, at cut 10a, and thereby bend out bar 9a and, in the illustrated embodiment, flap 14a to the positions illustrated at Fig. 5, at the same time forcing the end of the tie or ties through the slot 8a, formed by the bending out of bar 9a and flap 14a, and then draw the tie through the slot to approximately half the tie length and allow the tie to hang on bar 9a as illustrated at Fig. 5. In either case the hanger and ties are then laid on a cover sheet along the longitudinal central portion thereof between scorings 18 and the side portions of the sheet are then folded over the hanger and ties, eyes 17 and 17a engaging lugs 6c and 6d, and the coated edges pressed together, whereupon the assembly is complete.

We have illustrated two slots with bars and flaps but it will be obvious that either one slot with bar and flap, or several slots with bars and flaps, or slots with bars and no flaps may be provided. The bars, when bent to the Fig. 5 position, provide a relatively broad surface over

4

which the ties are hung, thereby preventing the creasing of the ties which would result from their being hung over a sharp lower edge of the slot. The outward bent bar also stiffens the body of the hanger element.

We have illustrated and described many details of construction but alternatives and equivalents will occur to those skilled in the art and within the expected skill of the calling, and we do not desire our protection limited to the details illustrated and/or described.

We claim:

1. An article for hanging and covering neckties comprising a piece of sheet material having a body portion, suspending means and a tie-receiving slot carried by the body portion, in combination with a cover member of sheet material adapted to be folded about said body portion, and ties carried thereby, and having pressure-sensitive-adhesive-coated areas on the opposite faces of its opposite margins, and projections carried by the body portion and eyes formed in the cover member positioned to interengage with said projections during the folding of the cover member about the body portion.

2. A necktie hanger and cover comprising, in combination, a substantially rectangular body of sheet material having a tie-receiving slot therein and a cover formed of a parallel sided sheet of foldable material of width more than twice that of the said body and having pressure-sensitive-adhesive coatings on its opposite faces along its opposite margins, whereby said covers may be stacked flat without adherence of one to another but may be folded around said body and ties, carried in said slot, to bring said marginal coatings into overlapping contact, and means carried by the body and cover adapted to interengage during and responsive to said folding of the cover around the body.

MYRON B. GWINN,
LEIGH WHITEHEAD.

REFERENCES CITED

The following references are of record in the file of this patent:

UNITED STATES PATENTS

Number	Name	Date
1,715,004	Johnson	May 28, 1929
1,850,169	De Fay	Mar. 22, 1932
2,488,973	Hall	Nov. 22, 1949