



US005294216A

# United States Patent [19]

[11] Patent Number: **5,294,216**

Sievert

[45] Date of Patent: **Mar. 15, 1994**

- [54] **COMPOSITE MASONRY BLOCK**
- [75] Inventor: **Dick J. Sievert**, New Richmond, Wis.
- [73] Assignee: **Anchor Wall Systems, Inc.**, Brooklyn Park, Minn.
- [21] Appl. No.: **651,322**
- [22] Filed: **Feb. 6, 1991**

- 1,456,498 5/1923 Binns .
- 1,465,608 8/1923 McCoy .
- 1,557,946 10/1925 Smith .
- 1,733,790 10/1929 Gilman .
- 1,907,053 5/1933 Flath .
- 2,094,167 9/1937 Evers .
- 2,121,450 6/1938 Sentrop .
- 2,197,960 4/1940 Alexander ..... 61/47
- 2,235,646 3/1944 Schaffer ..... 72/101
- 2,313,363 3/1943 Schmitt ..... 61/39
- 2,371,201 3/1945 Wells ..... 72/38
- 2,570,384 10/1951 Russell ..... 25/121
- 2,882,689 4/1959 Huch et al. .... 61/35

(List continued on next page.)

### Related U.S. Application Data

- [60] Division of Ser. No. 534,831, Jun. 7, 1990, Pat. No. 5,062,610, which is a continuation-in-part of Ser. No. 413,400, Sep. 28, 1989, abandoned, and a continuation-in-part of Ser. No. 413,050, Sep. 28, 1989, abandoned.

- [51] Int. Cl.<sup>5</sup> ..... **E02D 29/02**
- [52] U.S. Cl. .... **405/286; 52/604; 405/262**
- [58] Field of Search ..... **405/258, 273, 284, 285, 405/286; 52/561, 596, 604, 608, 609, 610**

### References Cited

#### U.S. PATENT DOCUMENTS

- 228,052 5/1880 Frost .
- D. 237,704 11/1975 Lane ..... D18/2
- D. 279,030 5/1985 Risi et al. .... D25/80
- D. 280,024 8/1985 Risi et al. .... D25/80
- D. 295,788 5/1988 Forsberg ..... D25/113
- D. 295,790 5/1988 Forsberg ..... D25/116
- D. 296,007 5/1988 Forsberg ..... D25/116
- D. 296,365 6/1988 Forsberg ..... D25/116
- D. 297,464 8/1988 Forsberg ..... D25/114
- D. 297,574 9/1988 Forsberg ..... D25/114
- D. 297,767 9/1988 Forsberg ..... D25/58
- D. 298,463 11/1988 Forsberg ..... D25/114
- D. 299,067 12/1988 Forsberg ..... D25/58
- D. 299,069 12/1988 Risi et al. .... D25/157
- D. 300,253 3/1989 Forsberg ..... D25/114
- D. 300,254 3/1989 Forsberg ..... D25/114
- 566,924 9/1896 Morrin .
- 810,748 1/1906 Haller et al. .
- 831,077 9/1906 Johnson .
- 1,092,621 4/1914 Worner .
- 1,219,127 3/1917 Marshall .
- 1,287,055 12/1918 Lehman .
- 1,414,444 5/1922 Straight .
- 1,419,805 6/1922 Bigler .

### FOREIGN PATENT DOCUMENTS

- 1188116 6/1985 Canada .

(List continued on next page.)

### OTHER PUBLICATIONS

Three Photographs of FIGS. 1-3. **Keystone™ Retaining Wall System Brochure.**

(List continued on next page.)

*Primary Examiner*—David H. Corbin  
*Attorney, Agent, or Firm*—Merchant, Gould, Smith, Edell, Welter & Schmidt

### [57] ABSTRACT

The present invention includes landscaping structures such as a retaining wall comprising a plurality of composite masonry blocks, the composite masonry block comprising a block body having an irregular trapezoidal shape and comprising a front surface and a back surface, an upper surface and a lower surface, and first and second sidewalls. Both the first and second sidewalls have a first and second part, the sidewall first part extends from the block front surface towards the block back surface at an angle of no greater than ninety degrees in relationship to the block front surface, the sidewall second part surfaces adjoins and lies between the sidewall first parts and the block back surface. The block also has a flange extending from the block back surface past the height of the block.

20 Claims, 5 Drawing Sheets

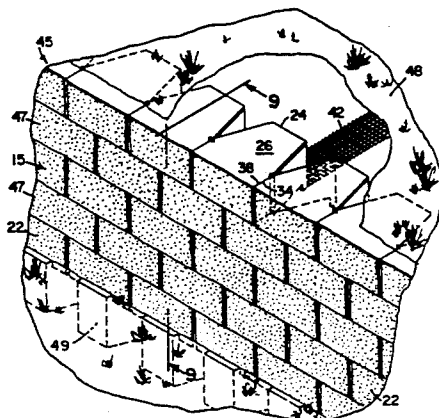

## U.S. PATENT DOCUMENTS

2,963,828	12/1960	Belliveau .....	50/425
3,036,407	5/1962	Dixon .....	50/443
3,204,316	9/1965	Jackson .....	25/121
3,274,742	9/1966	Paul et al. ....	52/245
3,390,502	7/1968	Carroll .....	52/424
3,430,404	3/1969	Muse .....	52/439
3,557,505	1/1971	Kaul .....	52/275
3,783,566	1/1974	Nielson .....	52/232
3,936,987	2/1976	Calvin .....	52/309
3,995,434	12/1976	Kato et al. ....	61/4
4,001,988	1/1977	Riefler .....	52/125
4,016,693	4/1977	Warren .....	52/405
4,023,767	5/1977	Fontana .	
4,098,040	7/1978	Riefler .....	52/125
4,107,894	8/1978	Mullins .....	52/593
4,110,949	9/1978	Cambiuzzi et al. ....	52/437
4,124,961	11/1978	Habegger .....	52/592
4,186,540	2/1980	Mullins .....	52/593
4,187,069	2/1980	Mullins .....	425/470
4,207,718	6/1980	Schaaf et al. ....	52/585
4,218,206	8/1980	Mullins .	
4,228,628	10/1980	Schlomann .....	52/438
4,229,123	10/1980	Heinzmann .....	405/273
4,288,960	9/1981	Auras .....	52/604
4,312,606	1/1982	Sarikelle .....	405/286
4,314,431	2/1982	Rabassa .....	52/259
4,335,549	6/1982	Dean .....	52/98
4,337,605	7/1982	Tudek .....	52/293
4,426,815	1/1984	Brown .....	52/100
4,490,075	12/1984	Risi et al. ....	405/273
4,496,266	1/1985	Ruckstuhl .....	404/41
4,512,685	4/1985	Hegle .....	405/284
4,572,699	2/1986	Rinninger .....	404/42
4,640,071	2/1987	Haener .....	52/286
4,660,342	4/1987	Salisbury .....	52/358
4,671,706	6/1987	Giardini .....	405/286
4,711,606	12/1987	Leling et al. ....	405/286
4,726,567	2/1988	Greenberg .....	256/19
4,784,821	11/1988	Leopold .....	264/510
4,802,320	2/1989	Forsberg .....	52/585
4,896,999	1/1990	Ruckstuhl .....	405/286
4,914,876	4/1990	Forsberg .....	405/286 X
5,017,049	5/1991	Sievert .....	405/284

## FOREIGN PATENT DOCUMENTS

62875	4/1989	Canada .
0170113A1	2/1986	European Pat. Off. .

1811932	6/1970	Fed. Rep. of Germany .
2755833	7/1978	Fed. Rep. of Germany .
3401629A1	7/1984	Fed. Rep. of Germany .
1360872	4/1964	France .
456776	7/1949	Italy .
657172A5	8/1986	Switzerland .
336	of 1871	United Kingdom .
1385207	2/1975	United Kingdom .
2127872	4/1984	United Kingdom .

## OTHER PUBLICATIONS

- Catalog sheet "The Allan Block Advantage" (date unknown).
- Technical Data Sheet "AZTECH™ Wall System" Anchor Block Co./Oscar Roberts Concrete Products Co. (circa. Jan. 1989).
- Technical Data Sheet for "Diamond™ Wall System" Anchor Block Co./Oscar Roberts Concrete Products Co. (circa. Jan. 1989).
- Diamond™ Installation Guide, American Masonry Products (circa. Jan. 1988) drawing, "Revetment Block", Columbia Machine, Inc. (Jan. 6, 1978).
- Standard Load Bearing Wall Tile p. 11, The Hollow Building Tile Assoc. Jan. 1924.
- "Modular Concrete Block"; Besson Co. Bulletin (Feb. 1985).
- "Paving Stone—New World Look with Old World Charm".
- "Ivany Block Retaining Walls".
- "The Estate Wall by Unilock", Unilock Chicago Inc.
- "Pisa II" Interlocking Retaining Wall Supplies for Garden Landscaping.
- Kiltie Corp., *Versa-Lok™ Retaining Wall Systems* brochure (date unknown).
- Johnson Block & Ready Mix Company, Inc., *Johnson Block Retaining Wall System* brochure (date unknown).
- Rockwood Retaining Wall Systems, Inc. *EZ Wall Systems* brochure (date unknown).
- Weiser Concrete, Inc., Weiser Slope Blocks advertisement (date unknown).
- Handy Stone™, a division of Kiltie Corp. of No. St. Paul, Minn., *Handy Stone™* product literature.

FIG. 1

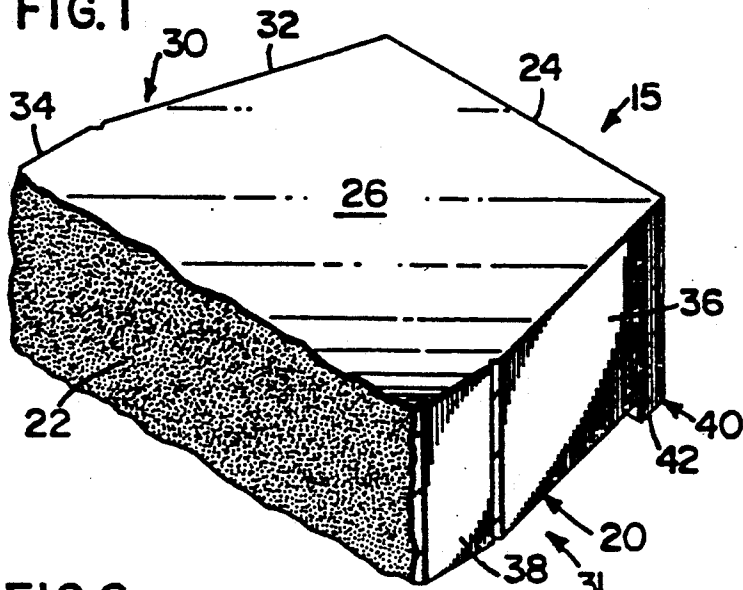

FIG. 2

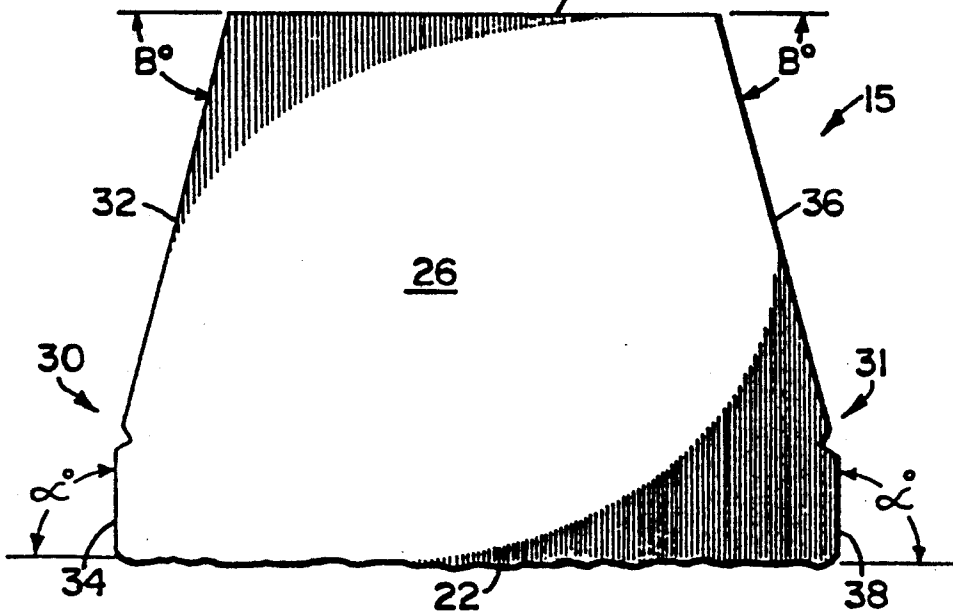

FIG. 3

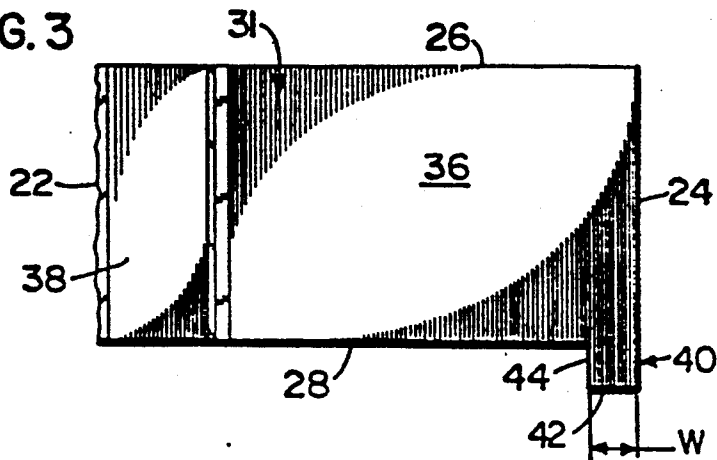

FIG. 4

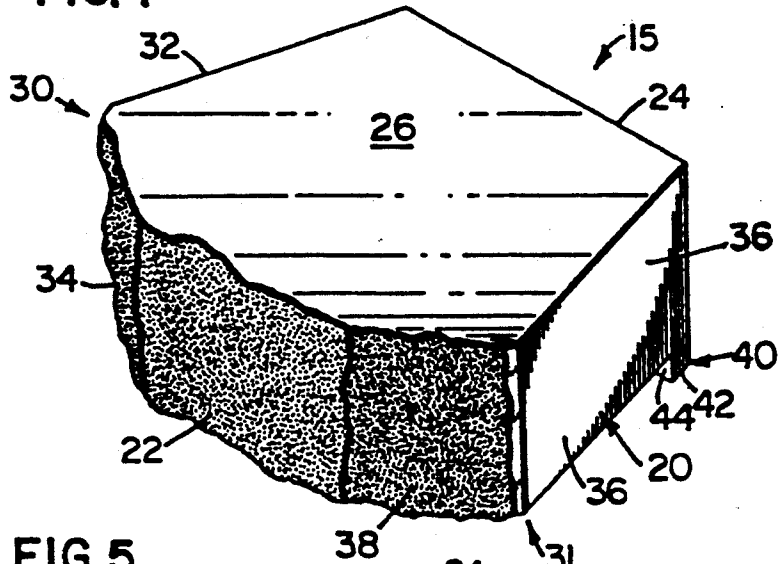

FIG. 5

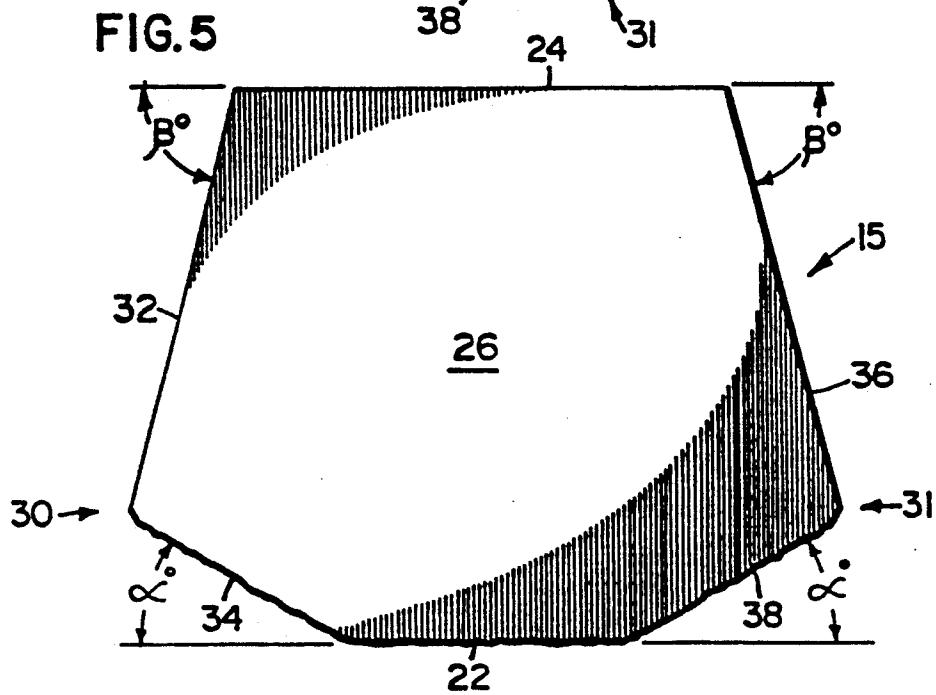
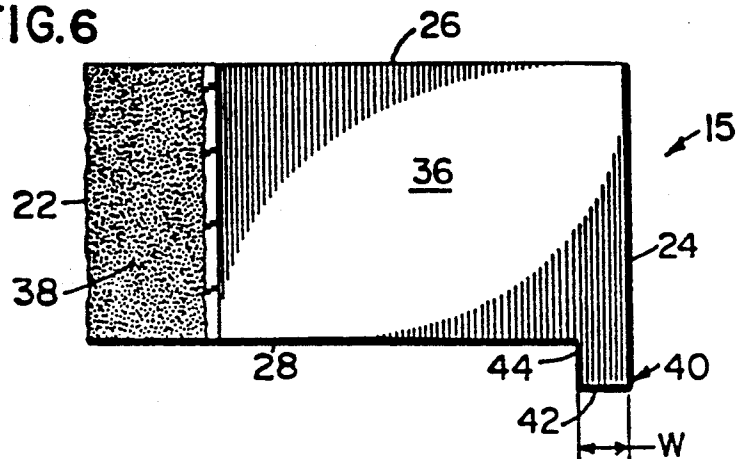

FIG. 6



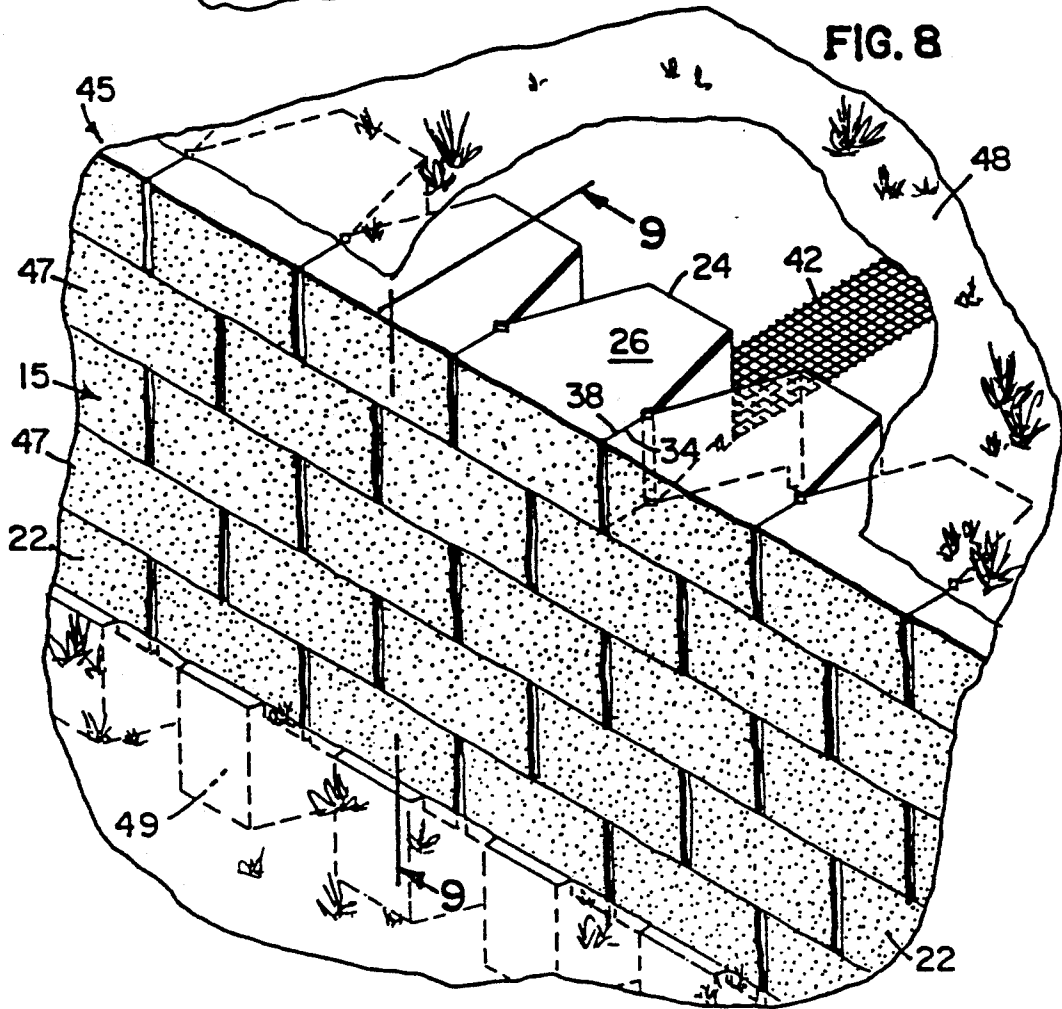
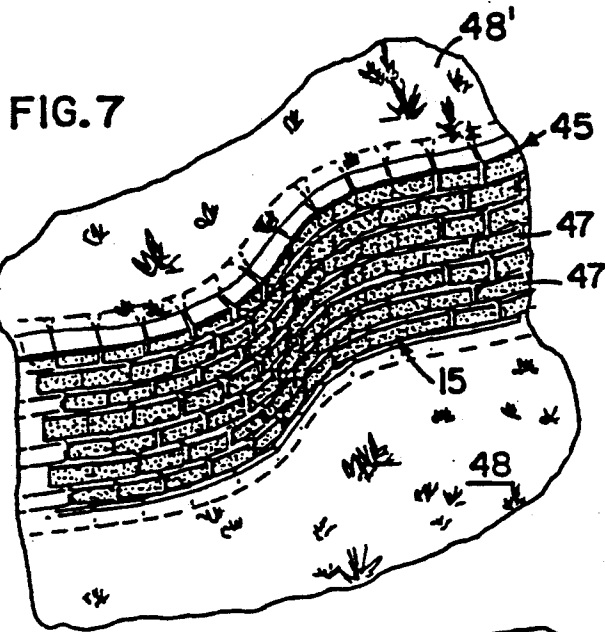

FIG. 9

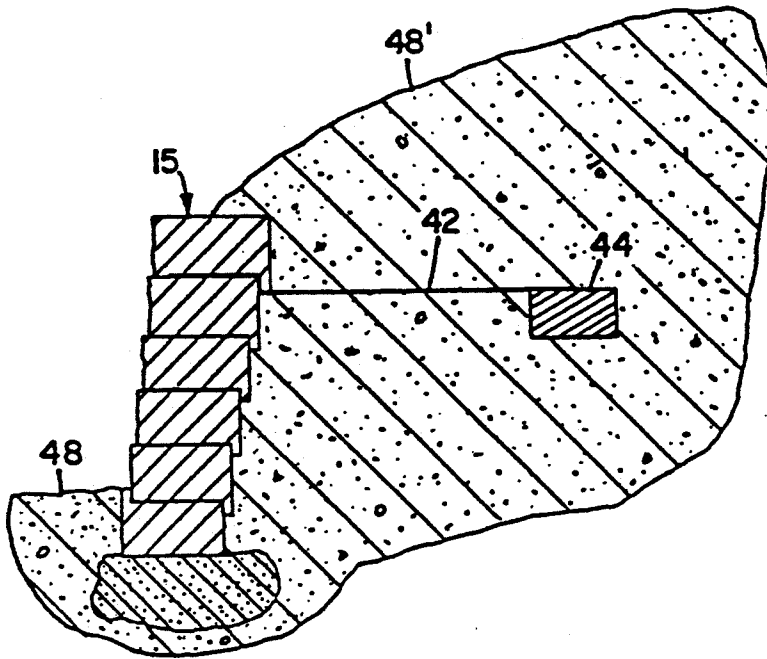

FIG. 10

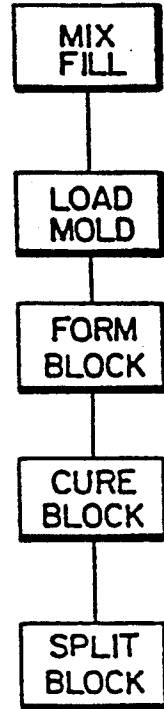

FIG. 11

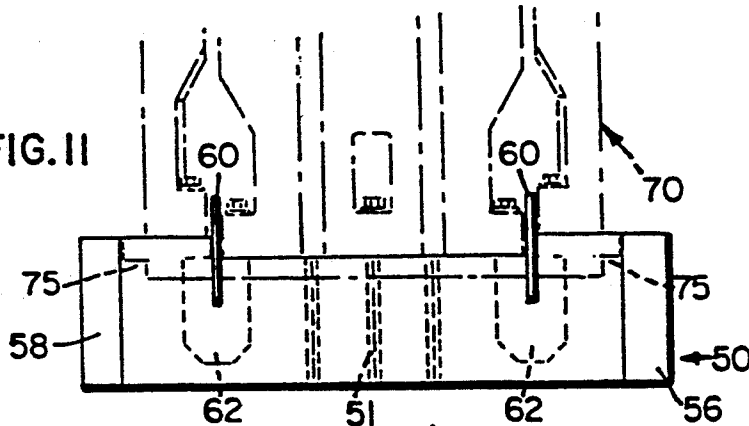
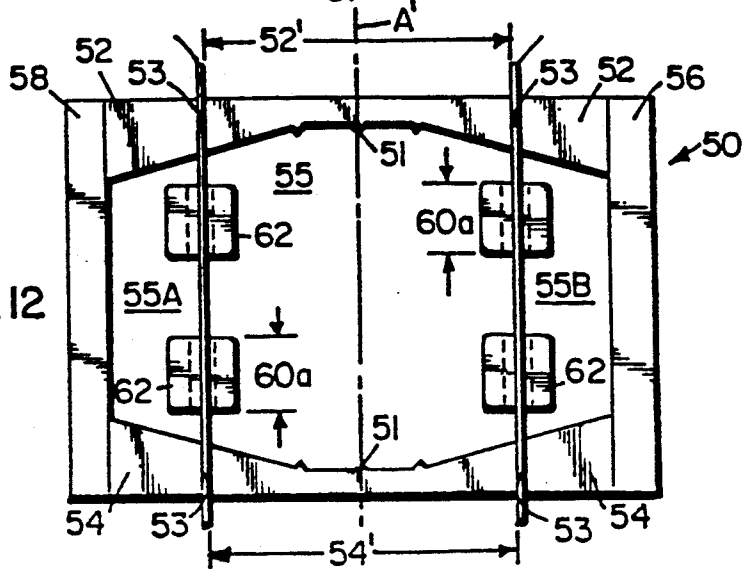

FIG. 12



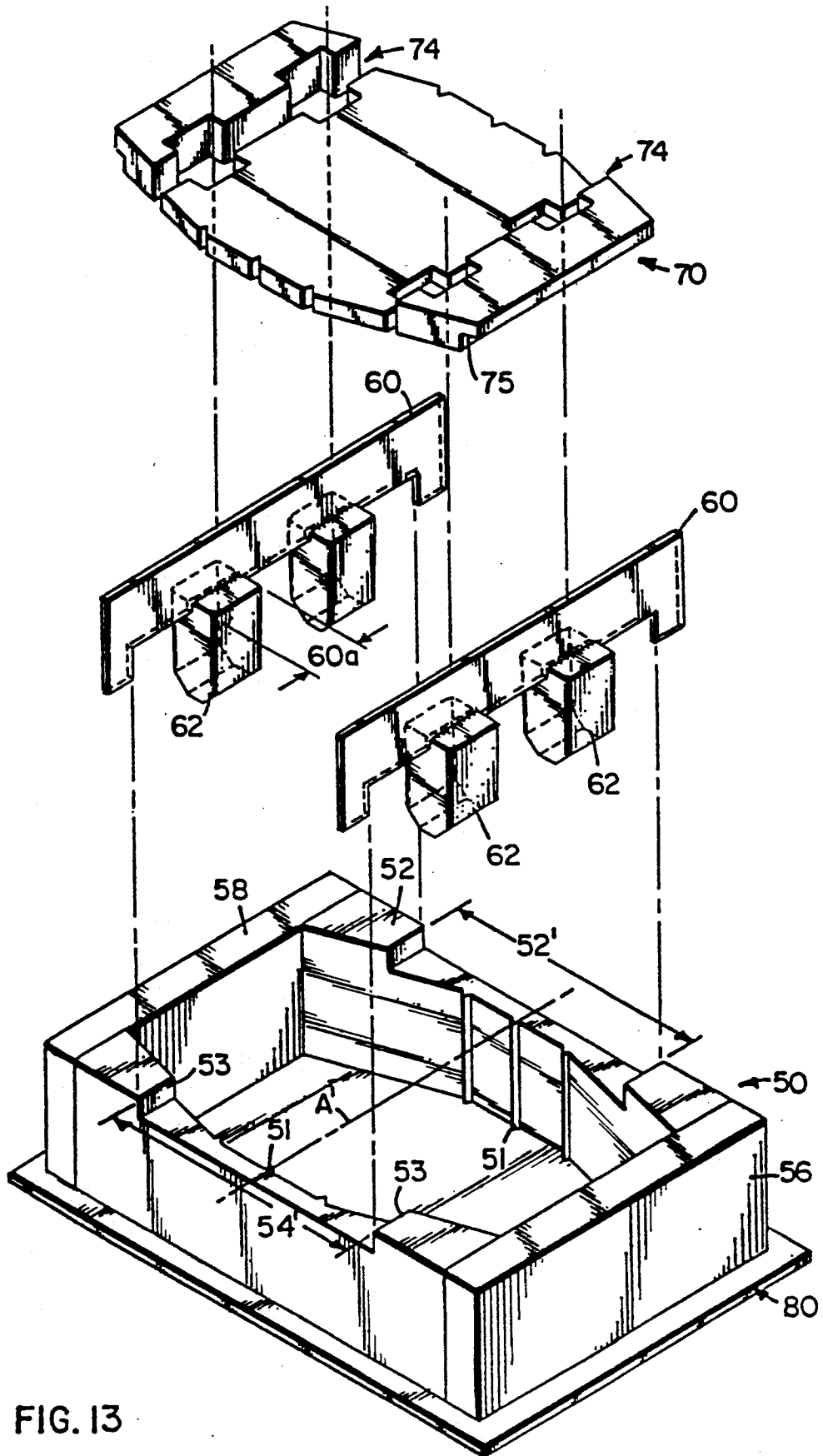

FIG. 13

## COMPOSITE MASONRY BLOCK

This is a divisional of application Ser. No. 07/534,831, filed Jun. 7, 1990, now U.S. Pat. No. 5,062,610, which is a continuation-in-part of U.S. patent application Ser. Nos. 07/413,400 and 07/413,050 both filed Sep. 28, 1989 and now abandoned.

### FIELD OF THE INVENTION

This invention relates generally to masonry blocks which may be used in the construction of landscaping elements. More specifically, the present invention relates to masonry block manufacturing processes and the resulting high strength masonry blocks which may be used to construct structures such as retaining walls of variable patterns.

### BACKGROUND OF THE INVENTION

Soil retention, protection of natural and artificial structures, and increased land use are only a few reasons which motivate the use of landscape structures. For example, soil is often preserved on a hillside by maintaining the foliage across that plane. Root systems from trees, shrubs, grass, and other naturally occurring plant life work to hold the soil in place against the forces of wind and water. However, when reliance on natural mechanisms is not possible or practical man often resorts to the use of artificial mechanisms such as retaining walls.

In constructing retaining walls many different materials may be used depending upon the given application. If a retaining wall is intended to be used to support the construction of an interstate roadway, steel or a concrete and steel retaining wall may be appropriate. However, if the retaining wall is intended to landscape and conserve soil around a residential or commercial structure a material may be used which compliments the architectural style of the structure such as wood timbers or concrete block.

Of all these materials, concrete block has received wide and popular acceptance for use in the construction of retaining walls and the like. Blocks used for these purposes include those disclosed by Risi et al, U.S. Pat. Nos. 4,490,075 and Des. 280,024 and Forsberg, U.S. Pat. Nos. 4,802,320 and Des. 296,007 among others. Blocks have also been patterned and weighted so that they may be used to construct a wall which will stabilize the landscape by the shear weight of the blocks. These systems are often designed to "setback" at an angle to counter the pressure of the soil behind the wall. Setback is generally considered the distance which one course of a wall extends beyond the front of the next highest course of the same wall. Given blocks of the same proportion, setback may also be regarded as the distance which the back surface of a higher course of blocks extends backwards in relation to the back surface of the lower wall courses. In vertical structures such as retaining walls, stability is dependent upon the setback between courses and the weight of the blocks.

For example, Schmitt, U.S. Pat. No. 2,313,363 discloses a retaining wall block having a tongue or lip which secures the block in place and provides a certain amount of setback from one course to the next. The thickness of the Schmitt tongue or lip at the plane of the lower surface of the block determines the setback of the blocks. However, smaller blocks have to be made with smaller tongues or flanges in order to avoid compromis-

ing the structural integrity of the wall with excessive setback. Manufacturing smaller blocks having smaller tongues using conventional techniques results in a block tongue or lip having inadequate structural integrity. Concurrently, reducing the size of the tongue or flange with prior processes may weaken and compromise this element of the block, the course, or even the entire wall.

Previously, block molds were used which required that the block elements such as a flange be formed from block mix or fill which was forced through the cavity of the mold into certain patterned voids within the press stamp or mold. The patterned voids ultimately become the external features of the block body. These processes relied on the even flow of a highly viscous and abrasive fill throughout the mold, while also not allowing for under-filling of the mold, air pockets in the fill or the mold, or any other inaccuracies which often occur in block processing.

The result was often that a block was produced having a well compressed, strong block body having weak exterior features. Any features formed on the block were substantially weaker due to the lack of uniform pressure applied to all elements of the block during formation. In turn, weaker exterior features on the outside of the block such as an interlocking flange could compromise the entire utility of the block if they crumble or otherwise deteriorate due to improper formation.

The current design of pinless, mortarless masonry blocks generally also fails to resolve other problems such as the ability to construct walls which follow the natural contour of the landscape in a radial or serpentine pattern. Previous blocks also have failed to provide a system allowing the use of anchoring mechanisms which may be affixed to the blocks without complex pinning or strapping fixtures. Besides being complex, these pin systems often rely on only one strand or section of a support tether which, if broken, may completely compromise the structural integrity of the wall. Reliance on such complex fixtures often discourages the use of retaining wall systems by the every day homeowner. Commercial landscapers generally avoid complex retaining wall systems as the time and expense involved in constructing these systems is not supportable given the price at which landscaping services are sold.

As can be seen the present state of the art of forming masonry blocks as well as the design and use of these blocks to build structure has definite shortcomings.

### SUMMARY OF THE INVENTION

In accordance with the present invention there is provided a composite masonry block comprising a block body having a front surface and a substantially parallel back surface, an upper surface and a lower surface, and first and second sidewall surfaces each comprising a first and second part. The sidewall first part extends from the block front surface towards the block back surface at an angle of no greater than ninety degrees in relationship to the block front surface. The sidewall second part adjoins and lies between the sidewall first part and the block back surface. The block of the present invention also comprises a flange extending from the block back surface past the height of the block.

In accordance with a further aspect of the present invention there are provided landscaping structures such as retaining walls comprising a plurality of courses, each of the courses comprising a plurality of the composite masonry blocks of the present invention.



In accordance with an additional aspect of the present invention there is provided a masonry block mold, the mold comprising two opposing sides and a front and back wall. The opposing sides adjoin each other through mutual connection with the mold front and back walls. The mold has a central cavity bordered by the mold opposing sides and the mold front and back wall. The mold opposing sides comprise stepped means for holding additional block mix in the mold cavity adjacent the front and back walls.

In accordance with another aspect of the present invention there is provided a method of using the composite masonry block mold of the present invention comprising filling the mold, subjecting the fill to pressure, and ejecting the formed masonry blocks from the mold.

#### BRIEF DESCRIPTION OF THE DRAWINGS

FIG. 1 is a perspective view of a preferred embodiment of the mortarless retaining wall block in accordance with the present invention.

FIG. 2 is a top plan view of the mortarless retaining wall block shown in FIG. 1.

FIG. 3 is a side elevational view of a mortarless retaining wall block shown in FIG. 1.

FIG. 4 is a perspective view of an alternative embodiment of the mortarless retaining wall block in accordance with the present invention.

FIG. 5 is a top plan view of the mortarless retaining wall block depicted in FIG. 4.

FIG. 6 is a side elevational view of the mortarless retaining wall block depicted in FIGS. 4 and 5.

FIG. 7 is a partially cut away perspective view of a retaining wall having a serpentine pattern constructed with one embodiment of the composite masonry block of the present invention.

FIG. 8 is a partially cut away perspective view of a retaining wall constructed with one embodiment of the composite masonry block of the present invention showing use of the block with anchoring matrices laid into the ground.

FIG. 9 is a cut away view of the wall shown in FIG. 8 taken along lines 9—9.

FIG. 10 is a schematic depiction of one embodiment of the method of the present invention.

FIG. 11 is a side elevational view of one embodiment of the masonry block mold in accordance with the present invention.

FIG. 12 is a top plan view of the masonry block mold shown in FIG. 11 in accordance with the present invention.

FIG. 13 is an exploded perspective view of one embodiment of the masonry block mold of the present invention showing application of the supporting bars, core forms, and stamp plate.

#### DETAILED DESCRIPTION OF THE PREFERRED EMBODIMENTS

Accordingly, the present invention provides a composite masonry block, structures resulting from this block, a masonry block mold for use in manufacturing the block of the present invention, and a method of using this mold. The present invention provides a mortarless interlocking masonry block having a high structural integrity which may be used to construct any number of structures having a variety of patterns. Moreover, the block of the present invention is made through a process and mold which facilitates and en-

hances the formation of a high strength block with an interlocking element which also has a high structural integrity and allows the fabrication of various landscaping structures of high strength.

#### COMPOSITE MASONRY BLOCK

Referring to the drawings wherein like numerals represent like parts throughout several views, a composite masonry block 15 is generally shown in FIGS. 1-3 and 4-6. The first aspect of the present invention is a composite masonry block having an irregular trapezoidal shaped block body 20.

The block body generally comprises a front surface 22 and a back surface 24 which are substantially parallel to each other. The front 22 and back 24 surfaces are separated by a distance comprising the depth of the block. The block also has an upper surface 26 and a lower surface 28 separated by a distance comprising the height of the block 15. The lower surface 28 generally has a smaller area proportion than the upper surface 26, FIG. 3.

The block also has a first 30 and second 31 sidewall separated by a distance comprising the width of the block, FIGS. 2 and 5. The sidewalls adjoin the block upper and lower surfaces. Both sidewalls comprise a first and second part. The sidewall first part extend from the block front surface towards the back surface at an angle of no greater than ninety degrees in relationship to the block front surface. The sidewall second part adjoins and lies between the first part and the block back surface.

The block also has a flange 40 spanning the width of the block back surface 24 and extending from the block back surface 24 past the height of the block, FIGS. 3 and 6. Generally, the flange comprises a setback surface 42 and a locking surface 44. The setback surface 42 extends from the lower edge of the flange 40 in a plane parallel to the block upper 26 and lower 28 surfaces towards the block front surface 22 to adjoin the flange locking surface 44. The locking surface extends from the plane of the block lower surface 28 and adjoins the setback surface 42.

The first element of the composite masonry block of the present invention is the body of the block 20, FIGS. 1-3. The block body 20 provides weight and physical structure to the system in which the block is used. Landscaping elements such as retaining walls often must be constructed of units which not only provide a structural impediment to resist the natural flow of soil, but must also provide the shear weight to withstand these forces. Moreover, the body of the block functions to provide the supporting surfaces which may be used to seat an aesthetically pleasing pattern such as that found on the front surface 22 of the block, FIG. 1. Finally the body of the block of the present invention provides a substrate for holding elements which help form an interlocking matrix with other blocks when used in a structure such as a wall. In particular, the block carries a flange 40 which assists in the interlocking function of the block.

Generally, the block may take any number of shapes in accordance with the present invention. Distinctive of the present invention is the ability to use the block seen in FIGS. 1-3 and 4-6 to construct either straight or serpentine walls. Accordingly, the block of the present invention preferably has an irregular trapezoidal shape having a parallel front 22 and back surfaces 24, FIG. 2. The necessarily irregular nature of the trapezoidal

block of the present invention comes from the blocks two part sidewalls 30, 31, FIG. 2.

As can be seen, the block body 20 generally has eight surfaces. The front surface 22 generally faces outward from the structure and may either have a plain or a roughened appearance to enhance the blocks aesthetic appeal. In fact, the block front surface 22 may be smooth, rough, planar or nonplanar, single faceted or multifaceted.

The back surface 24 of the block generally lies parallel to the front surface 22. The top surface 26 generally lies parallel to the bottom surface 28. As can be seen, FIG. 3, the upper surface has a greater depth across the block than the lower surface 28. Generally, the difference in depth between the upper surface 26 and the block lower surface 28 is attributable to the position of the flange 40, extending in part from the lower surface of the block, FIG. 3.

The block body sidewall surfaces 30, 31 lie across the width of the block, FIG. 2. The sidewalls of the block body of the present invention allow for the construction of straight structures or serpentine structures and more particularly outside radius turns. Accordingly, the block sidewalls are preferably of two-part construction. As can be seen in FIG. 2, the block sidewall first parts 34, 38 extend on either side of the block from the block front surface at an angle, alpha, of approximately ninety degrees toward the block back surface, FIG. 2.

Generally, at about one-fifth to about one-quarter of the depth of the block, the sidewall first part 38 joins the sidewall second part, FIGS. 2 and 3. The sidewall second part 32, 36 generally continue further towards the back surface 24 of the block body. Preferably, the sidewall second surfaces converge towards each other as these surfaces move towards the back surface of the block. The angle, beta, of the sidewall second preferably ranges in magnitude from about 30 degrees to about 60 degrees in relation to the block back surface, FIG. 2. This provides structures having a more aesthetically preferable or pleasing appearance by avoiding a "stepped" appearance which results from the adjacent placement of blocks having an extreme sidewall angle.

The two-part sidewalls allow for the construction of aligned, straight walls given the sidewall first part which aligns with adjoining sidewall first parts of blocks in the same wall course, (see 34, 38, FIG. 8). Optionally, the same embodiment of the block of the present invention allows the construction of aligned serpentine structure 45, FIG. 7.

Alternatively, the first part of the sidewall surfaces may have an angle, alpha, which is less than ninety degrees, FIGS. 4-6. This embodiment of the block of the present invention may more preferably be used in the construction of serpentine structures such as that shown in FIG. 7. In this instance, the block sidewall first part provides a block with a more aesthetically refined, rounded or multi-faceted front surface 22, FIG. 4. The sidewall second part in this embodiment of the block of the present invention also converge along angle, beta, towards the rear surface of the block allowing the construction of a structure similar to that shown in FIG. 7.

The block of the present invention also comprises a flange 40, FIGS. 3 and 6. The flange 40 assists in providing an effective interlocking mechanism which stabilizes the structures made in accordance with the present invention. Moreover, the block mold and method of molding blocks of the present invention allow the for-

mation of block elements, such as flange 40, having high structural strength. The processing simultaneously affords the construction of interlocking elements having minimal size. The result of flanges having such minimal size is a structure having minimal setback and maximum stability given the weight and proportions of the blocks used.

The flange 40 may take any number of forms. Preferably, the flange 40 spans the width the blocks back surface 24 and extends from the block back surface beyond the height of the block. Generally, the flange 40 will extend beneath the lower surface of the block so that when stacked the flange 40 of each ascending block will hang over and lock onto the back surface of the block of the adjacent block in the next lowest course, FIG. 9.

The flange 40 may comprise any number of surfaces to aid in seating and locking the block in place. Preferably, the flange has a setback surface 42 and a locking surface 44. The setback surface generally adjoins and extends from the lower edge of the flange in a plane parallel to the block upper and lower surfaces. Adjoining the flange setback surface 42 and the block lower surface 28 is the flange locking surface 44, FIGS. 3 and 6.

The width of the setback surface determines the amount that the blocks of each successive course will setback from blocks from the next lower course. Generally, each successive course of blocks should setback far enough to maintain the stability of the soil behind the wall. In turn, flange 40 generally should be large enough to provide a high strength interlocking element, while remaining small enough to retain the stability of the wall. To this end, the width W of the setback surface 42, FIGS. 3 and 6, generally ranges in width from about 1 inch to about 2 inches across its base. This width range provides minimal setback while ensuring the provision of a strong flange.

In its most preferred mode, the block of the present invention is suitable for both commercial and residential use by landscapers as well as homeowners for use in building landscape structures. In this instance, the block generally weighs from about 50 lbs. to about 100 lbs. and more preferably 65 lbs. to 75 lbs. and has a height of about 3 inches to 12 inches, and more preferably 3 inches to 6 inches, a width of about 12 inches to about 18 inches, and more preferably 14 inches to 16 inches, and a length of about 6 inches to about 24 inches and more preferably 14 inches to about 16 inches. These measurements allow the maintenance of the appropriate weight to width ratio of the block, provide a block weighted to allow manual transport by one person, and ensures optimal efficiency in the use of machinery.

#### BLOCK STRUCTURES

The composite masonry block 15 of the present invention may be used to build any number of landscape structures. Examples of the structures which may be constructed with the block of the present invention are seen in FIGS. 7-9. As can be seen in FIG. 7, the composite masonry block of the present invention may be used to build a retaining wall 45 using individual courses 47 to construct to any desired height. The blocks may be stacked in an even pattern or an offset pattern depending on the intended application.

Generally, construction of a structure such as a retaining wall 45 may be undertaken by first defining a trench area beneath the plane of the ground 48 in which

to deposit the first course 49 of blocks, FIGS. 7 and 8. Once defined, the trench is partially refilled and tamped or flattened. The first course 49 of blocks is then laid into the trench, FIG. 8. The first course of blocks may 5  
 10  
 15  
 20  
 25  
 30  
 35  
 40  
 45  
 50  
 55  
 60  
 65  
 70  
 75  
 80  
 85  
 90  
 95  
 100  
 105  
 110  
 115  
 120  
 125  
 130  
 135  
 140  
 145  
 150  
 155  
 160  
 165  
 170  
 175  
 180  
 185  
 190  
 195  
 200  
 205  
 210  
 215  
 220  
 225  
 230  
 235  
 240  
 245  
 250  
 255  
 260  
 265  
 270  
 275  
 280  
 285  
 290  
 295  
 300  
 305  
 310  
 315  
 320  
 325  
 330  
 335  
 340  
 345  
 350  
 355  
 360  
 365  
 370  
 375  
 380  
 385  
 390  
 395  
 400  
 405  
 410  
 415  
 420  
 425  
 430  
 435  
 440  
 445  
 450  
 455  
 460  
 465  
 470  
 475  
 480  
 485  
 490  
 495  
 500  
 505  
 510  
 515  
 520  
 525  
 530  
 535  
 540  
 545  
 550  
 555  
 560  
 565  
 570  
 575  
 580  
 585  
 590  
 595  
 600  
 605  
 610  
 615  
 620  
 625  
 630  
 635  
 640  
 645  
 650  
 655  
 660  
 665  
 670  
 675  
 680  
 685  
 690  
 695  
 700  
 705  
 710  
 715  
 720  
 725  
 730  
 735  
 740  
 745  
 750  
 755  
 760  
 765  
 770  
 775  
 780  
 785  
 790  
 795  
 800  
 805  
 810  
 815  
 820  
 825  
 830  
 835  
 840  
 845  
 850  
 855  
 860  
 865  
 870  
 875  
 880  
 885  
 890  
 895  
 900  
 905  
 910  
 915  
 920  
 925  
 930  
 935  
 940  
 945  
 950  
 955  
 960  
 965  
 970  
 975  
 980  
 985  
 990  
 995

As can be seen in FIGS. 7 and 8 the blocks of the present invention allow for the production of serpentine or straight walls. The blocks may be placed at an angle in relationship to one another so as to provide a serpentine pattern having convex and concave surfaces, FIG. 7. Moreover, depending on which embodiment of the block of the present invention is used, various patterns, serpentine or straight, may be produced in any given structure.

One benefit of the blocks of the present invention is their two part sidewall. While the first part of the side wall has a right angle in relationship to the front surface of the block 22, the second part of the block sidewalls converge or angle towards each other as the sidewall moves towards the back surface 24 of the block. The converging second part of the block sidewalls allows the blocks to be set in a range of angles relative to adjacent blocks of the same course, FIG. 7.

Moreover, when a straight wall is desired, FIG. 8, the blocks of the present invention allow for the placement of the blocks flush against each other. As can be seen in FIG. 8, block sidewall first part surfaces 38 and 34 of two adjacent blocks are flush against one another. This allows for the construction of a wall having tighter block placement.

In contrast, if a more highly angled serpentine wall is desired the block depicted in FIGS. 4-6 may be used. This block comprises sidewall first parts 34, 38 which have an angle and which may be less than 90°. As can be seen, the sidewalls first part 34, 38 effectively become the second and third faces along with the block front surface 22, of a three faceted front of the block. The lack of a 90° sidewall first part shortens the effective length of the block depicted in FIGS. 4-6. Thus, in angling the blocks of FIGS. 4-6 the length of the sidewalls first part 34, 38 does not become a factor block placement. As a result blocks of the same relative size and weight may be used more efficiently given limited space.

As can be seen in FIG. 8, a supporting matrix 42 may be used to anchor the blocks in the earth fill 48' behind the wall. One advantage of the block of the present invention is that despite the absence of pins, the distortion created by the block flange 40 anchors the entire width of the matrix 42 when pressed between two adjacent blocks of different courses, FIG. 9.

In this instance, a wall is constructed again by forming a trench in the earth. The first course 49 of the wall is seated in the trench and will be under soil once the wall is backfilled. The blocks 15 are placed on a securing mat or matrix 42 which is secured within the bank 48' by deadheads 44. The deadheads 44 serve as an

additional stabilizing factor for the wall providing additional strength. The deadheads 44 may be staggered at given intervals over the length of each course and from course to course to provide an overall stability to the entire wall structure.

#### BLOCK MOLDING THE BLOCKS

An additional aspect of the present invention is the process for casting or forming the composite masonry blocks of this invention using a masonry block mold. Generally, the process for making this invention includes block molding the composite masonry block by filling a block mold with mix and casting the block by compressing the mix in the mold through the application of pressure to the exposed mix at the open upper end of the block mold. Formation of the block of the present invention is undertaken with a stepped mold to ensure that the pressure applied to the entire block 15 is uniform across the body 20 and flange 40.

An outline of the process can be seen in the flow chart shown in FIG. 10. Generally, the processes is initiated by mixing the concrete fill. Any variety of concrete mixtures may be used with this invention depending upon the strength, water absorption, density, and shrinkage among other factors desired for the given concrete block. One mixture which has been found to be preferable includes cementitious materials such as cement or fly ash, water, sand, and gravel or rock. However, other components including plasticizers, water proofing agents, cross-linking agents, dyes, colorants, pigments etc. may be added to the mix in concentrations up to 5 wt-% depending upon the physical characteristics which are desired in the resulting block.

Blocks may be designed around any number of different physical properties in accordance with ASTM Standards depending upon the ultimate application for the block. For example, the fill may comprise from 75 to 95% aggregate being sand and gravel in varying ratios depending upon the physical characteristics which the finished block is intended to exhibit. The fill generally also comprises some type of cementitious materials at a concentration ranging from 4% to 12%. Other constituents may then be added to the fill at various trace levels in order to provide blocks having the intended physical characteristics.

Generally, once determined, the fill constituents may be placed in any number of general mixers including those commonly used by those with skill in the art for mixing cement and concrete. To mix the fill, the aggregate, the sand and rock, is first dumped into the mixer followed by the cement. After one to two and one-half minutes, any plasticizers that will be used are added. Water is then introduced into the fill in pulses over a one to two minute period. The concentration of water in the mix may be monitored electrically by noting the resistance of the mix at various times during the process. While the amount of water may vary from one fill formulation to another fill formulation, it generally ranges from about 1% to about 6%.

Once the fill is mixed, the fill is then loaded into a hopper which transports the fill to the mold 50 within the block machine, FIGS. 11 and 12.

The mold 50 generally comprises at least four sides bordering a central cavity. As can be seen in FIG. 12, the mold generally has a front wall 58, a back wall 56, and a first 52 and second 54 opposing side. The opposing sides (52, 54) are each generally stepped in area 53 having a depressed center length (52', 54') and an ele-

vated higher end adjacent the front and back walls, FIG. 11. The central cavity 55 is bordered by these walls.

Core forms 62 may also be placed in the mold cavity 55 prior to loading the mold with block mix. Generally, the core forms 62 may be supported by bars 60 positioned across opposing first 52 and second 54 sidewalls and adjacent to the stepped regions 53 in each of these sidewalls.

Turning to the specific aspects of the mold, the mold functions to facilitate the formation of the blocks. Accordingly, the mold may comprise any material which will withstand the pressure to be applied to block fill by the head. Preferably, metals such as steel alloys having a Rockwell "C"-scale ranging from about 60-65 provide optimal wear resistance and the preferred rigidity. Generally, metals found useful in the manufacture of the mold of the present invention include high grade carbon steel 41-40 AISI (high nickel content, prehardened steel), carbon steel 40-50 (having added nickel) and the like. A preferred material includes carbon steel having a structural ASTM of A36.

The mold of the present invention may be made by any number of means known to those of skill in the art. Generally, the mold is produced by cutting the stock steel, patterning the cut steel, providing an initial weld to the patterned mold pieces and heat treating the mold. Heat treating generally may take place at temperatures ranging from 1000° F. to 1400° F. for 4 to 10 hours depending on the ability of the steel to withstand processing and not distort. After heat treating, final welds are then applied to the pieces of the mold.

Turning to the individual elements of the mold, the mold walls generally function according to their form by withstanding the pressure created by the press. Further, the walls measure the height and depth of the resulting blocks. Accordingly the mold walls must be made of a thickness which will accommodate the processing parameters of block formation given a specific mold composition. Preferably, the mold walls range in thickness from about 0.25 inch to about 2.0 inches, preferably from about 0.75 inch to 1.5 inches.

Additionally, the mold sidewalls function to ensure that uniform pressure is applied throughout the entire block during formation. Uniform pressure on all block elements is ensured by retaining additional block fill or mix adjacent the mold front 56 and back 58 wall in areas 55A and 55B, which will be the area in which the block flange 40 (FIGS. 3 and 6) is formed. By retaining mix in areas 55A and 55B, the same compression is applied to the mix which becomes the block body and to the mix which becomes the block flange. The application of uniform pressure to the block flange allows the construction of smaller blocks having smaller, stronger flanges. In turn, a smaller flange provides a block which results in a more vertical structure such as a wall having less setback from course to course and, as a result, greater stability over its height.

Generally, the mold sidewalls 52, 54 may take any form which provides this function. Preferably, the mold sidewalls 52, 54 are stepped 53 as can be seen in FIGS. 11 and 12. Turning to FIG. 11, mold sidewall 54 is stepped twice across its length in region 53 to create a depressed central length 54' in the sidewall 54. In FIG. 11, the mold 50 is shown during the actual block formation step, with the head 72 compressed onto the block fill in the mold 50.

The mold may preferably also comprise support bars 60 and core forms 62. The support bars 60 hold the core forms 62 in place and act as a stop for block fill or mix which is retained in the elevated (or stepped) region of the mold 50 thereby preventing the fill from flowing back into the area bordered by the depressed central lengths 52' and 54' of sidewalls 52 and 54. Here again, the support bars may take any shape, size material composition which provides these functions.

As can be seen more clearly in FIG. 12, support bar 60 is preferably long enough to span the width of mold 50 resting on opposing sidewalls 52 and 54. Preferably the support bars 60 are high enough to restrict the flow of fill into the central area of the mold cavity 55. Complementing this function, the support bars 60 are generally positioned in the depressed central areas 52' and 54' of the opposing sidewalls immediately adjacent stepped region 53, FIG. 12.

As can be seen in outline in FIG. 11, the core forms 62 are supported by bars 60 which span the width of the mold 50 resting on the opposing sidewalls 52, 54. The head 72 and head stamp 70 (also seen in outline (FIG. 11)) are patterned to avoid contact with the core forms 62 and support bars 60.

The core forms have a number of functions. The core forms 62 act to form voids in the resulting composite masonry block. In turn, the core forms lighten the blocks, reduce the amount of fill necessary to make a block and add a handle to the lower surface of the block which assists in transport and placement of the blocks. In concert with these functions the cores may take any number of forms. Preferably, the core forms are approximately three inches square and penetrate from about 60% to about 80% of the blocks height and most preferably about 70% to 80% of the block height. Also preferred, as can be seen in the exploded view provided in FIG. 13, the core forms 62 are affixed to the support bar 60 at insert regions 60A. These insert regions 60A assist in positioning the cores and during processing, reduce the build up of block mix or fill on the lower edge of the support bar 60. In turn, maintaining a support bar 60 clean of mix build up maintains the planarity of the lower surface of blocks formed in accordance with the present invention.

In operation, the mold 50 is generally positioned in a block molding machine atop a removable or slidable substrate 80, FIG. 13. The support bars 60 and core forms 62 are then placed into the mold 50. The mold 50 is then loaded with block mix or fill. As configured in FIG. 12, the mold 50 is set to form two blocks simultaneously in "siamese" pattern. As will be seen, once formed and cured, the blocks may be split along the edge created by flange 51 generally along axis A.

Prior to compression the upper surface of the mold 50 is scraped or raked with a feed box drawer (not shown) to remove excess fill. Scraping of the mold is preferably undertaken in a side-to-side direction in order to avoid contact with the side bars 60. Also, removal of the excess fill from the mold by scraping from the side allows for the depressed central lengths 52' and 54' of the mold and does not disturb the fill at the stepped ends of the mold 50.

The mold is then subjected to compression directly by head 70 (shown in outline complete in FIG. 11 and in perspective in FIG. 13). Preferably the head 70 is patterned 74 to avoid the support bars 60 and core forms 62. Also, as can be seen in FIG. 13, the head 70 preferably has an instep 75 which shape complements and

results in, the formation of the block flange 40. Instead of relying on the head to force block fill towards either end of the mold 50 into instep 75 to create a flange, the mold 50 maintains fill in the stepped regions at either end of the mold 50. The fill in these regions comes into direct contact with instep 75 immediately upon lowering of the head 70. As a result, the fill in this stepped area is subjected to the same pressure as the fill in other areas of the mold. This results in a flange 40 of the same structural strength as the other elements of the block 15.

Once the mold has been filled, leveled by means such as a feed-box drawer, and agitated, a compression mechanism such as a head converges on the exposed surface of the fill. The head acts to compress the fill within the mold for a period of time sufficient to form a solid contiguous product. The head 70, as known to those of skill in the art, is a unit which has a pattern which mirrors the blocks and core forms 62 and is complementary to that of the mold 50. Generally, the compression time may be anywhere from  $\frac{1}{2}$  to 3 seconds and more preferably about 1.5 to about 2 seconds. The compression pressure applied by the head ranges from about 5000 to 8000 psi and preferably is about 7500 psi. Once a compression period is over, the head in combination with an underlying pallet 80 acts to strip the blocks 15 from the mold 50. At this point in time, the blocks are formed. Any block machine known to those of skill in the art may be used. One machine which has been found useful in the formation of blocks in accordance with the present invention is a Besser V-3/12 block machine.

Prior to compression the mold may be vibrated. Generally, the fill is transported from the mixer to a hopper which then fills the mold 50. The mold is then agitated for up to two or three seconds, the time necessary to ensure that the fill has uniformly spread throughout the mold. The blocks are then formed by the compressing action of the head.

Once the blocks are formed, they may be cured through any means known to those of skill in the art. Curing mechanisms such as simple air curing, autoclaving, steam curing or mist curing, are all useful methods of curing the block of the present invention. Air curing simply entails placing the blocks in an environment where they will be cured by the open air over time. Autoclaving entails placing the blocks in a pressurized chamber at an elevated temperature for a certain period of time. The pressure in the chamber is then increased by creating a steady mist in the chamber. After curing is complete the pressure is released from the chamber which in turn draws the moisture from the blocks.

Another means for curing blocks is by steam. The chamber temperature is slowly increased over two to three hours and then stabilized during the fourth hour. The steam is gradually shut down and the blocks are held at the eventual temperature, generally around 120°-200° F. for two to three hours. The heat is then turned off and the blocks are allowed to cool. In all instances, the blocks are generally allowed to sit for twelve to twenty-four hours before being stacked or stored. Critical to curing operations is a slow increase in temperature. If the temperature is increased too quickly, the blocks may "case-harden." Case-hardening occurs when the outer shell of the blocks hardens and cures while the inner region of the block remains uncured and moist. While any of these curing mechanisms will work, the preferred curing means is autoclaving.

Once cured, the blocks may be split if they have been cast "siamese" or in pairs. Splitting means which may

be used in the method of the present invention include a manual chisel and hammer as well as machines known to those with skill in the art for such purposes. Splitting economizes the production of the blocks of the present invention by allowing the casting of more than one block at any given time. When cast in pairs, the blocks 15, FIG. 13, may be cast to have an inset groove created by flange 51 on their side surfaces between the two blocks. This groove provides a natural weak point or fault which facilitates the splitting action along axis A'. The blocks may be split in a manner which provides a front surface 22 which is smooth or coarse, single-faceted or multi-faceted, as well as planar or curved. Preferably, splitting will be completed by an automatic hydraulic splitter. Once split, the blocks may be cubed and stored.

The above discussion, examples, and embodiments illustrate our current understanding of the invention. However, since many variations of the invention can be made without departing from the spirit and scope of the invention, the invention resides wholly in the claims hereafter appended.

We claim as our invention:

1. A retaining wall comprising at least a first lower course and a second upper course, each of said courses comprising one or more composite masonry blocks, each of said masonry blocks comprising:

(a) a block body, said block body comprising a front surface and a back surface separated by a distance comprising the depth of the block, an upper surface and a lower surface separated by a distance comprising the height of the block, and first and second sidewall surfaces adjoining said block upper and lower surfaces—both said first and second sidewall surfaces each comprising a first and second part, said sidewall first part surfaces extending from said block front surface towards said block back surface at an angle of no greater than ninety degrees in relationship to said block front surface, said sidewall second part surface adjoining and lying between said sidewall first parts and said block back surface; and

(b) a flange affixed to the block adjacent said rear surface and extending downwardly from said block body, said flange comprising a locking surface adapted to nest with the next lowest course of blocks, said locking surface extending downwardly from the plane of said block lower surface; said wall further comprising at least one anchoring matrix interposed between a portion of at least said first course block and a portion of at least said second course block wherein the lower surface of said second course block is positioned on top of the upper surface of said first course block, the block flange of said second course block being positioned adjacent and behind the block back surface of said first course block, said anchoring matrix is distorted by said second course block flange and said matrix is fixed in position between the first and second courses by the distorted interposition of said matrix between said first and second course blocks and the weight of said second course.

2. The retaining wall of claim 1 wherein said retaining wall masonry blocks comprise sidewall first part surfaces extending from said block front surface towards said block back surfaces at an angle of less than ninety degrees in relationship to said block front surface.

3. The retaining wall of claim 2 wherein said wall comprises at least one anchoring matrix positioned be-

tween at least two adjacent blocks of two difference courses.

4. The wall of claim 2 wherein said wall has a serpentine pattern.

5. The retaining wall of claim 1 wherein the block of said first course is vertically offset from the block of said second course.

6. The retaining wall of claim 1 wherein said block body lower surface has a smaller area than said block body upper surface.

7. The retaining wall of claim 1 wherein said retaining wall blocks comprise a block body having a first and second side wall separated by a distance comprising the width of the block, said block flange spanning the width of said block back surfaces.

8. The retaining wall of claim 1 wherein said block body front surface is concave.

9. The retaining wall of claim 8 wherein said wall has a serpentine pattern.

10. The retaining wall of claim 1 wherein said block body front surface is substantially planar.

11. The retaining wall of claim 1 wherein said block body front surface is faceted.

12. The retaining wall of claim 1 wherein said block flange comprises a set back surface, said set back surface extending from said flange in a plane parallel to the block upper and lower surfaces and towards said block front surface to adjoin said flange locking surface.

13. A retaining wall comprising at least a first lower course and a second upper course, each of said courses comprising:

- (a) one or more composite masonry blocks, each of said blocks comprising a block body comprising a front surface and a back surface separated by a distance comprising the depth of the block, an upper surface and a lower surface separated by a distance comprising the height of the block, and first and second sidewall surfaces adjoining said block upper and lower surfaces, said upper and lower surfaces adjoining said front and back surfaces, and said front and back surfaces adjoining said first and second sidewall surfaces, wherein

each of said surfaces meet to form an edge and wherein at least said second upper course block comprises a flange adjacent said second course block back surface extending downwardly from said second course block lower surface, said flange comprising a locking surface adapted to nest with an edge of a block in the next lower course; and

- (b) at least one anchoring matrix interposed between a portion of said first course block and a portion of said second course is positioned on top of the upper surface of said first course block, the back edge of said first course block being nested against the flange locking surface of said second course block, said anchoring matrix being distorted by the locking surface of said second course block and said matrix being fixed in position between the first and second course blocks by the distorted interposition of said matrix between said first and second course blocks.

14. The retaining wall of claim 13 wherein said wall has a serpentine pattern.

15. The retaining wall of claim 13 wherein said block body lower surface has a smaller area than said block body upper surface.

16. The retaining wall of claim 13 wherein said block body front surface is concave.

17. The retaining wall of claim 13 wherein said block body front surface is substantially planar.

18. The retaining wall of claim 13 wherein said block body front surface is faceted.

19. The retaining wall of claim 13 wherein said block flange comprises a set back surface, said set back surface extending from said flange in a plane parallel to the block upper and lower surfaces and towards said block front surface to adjoin said flange locking surface.

20. The retaining wall of claim 13 wherein said first lower course block comprises a flange adjacent said first course block back surface and extending downwardly from said first course block lower surface, said flange comprising a locking surface adapted to nest with an edge of an adjacent block.

\* \* \* \* \*

45

50

55

60

65



US005294216C1

(12) **EX PARTE REEXAMINATION CERTIFICATE (5671st)**

**United States Patent**  
**Sievert**

(10) **Number:** **US 5,294,216 C1**  
(45) **Certificate Issued:** **Feb. 13, 2007**

- (54) **COMPOSITE MASONRY BLOCK**
- (75) Inventor: **Dick J. Sievert**, New Richmond, WI (US)
- (73) Assignee: **Anchor Wall Systems, Inc.**, Minneapolis, MN (US)

3,679,340 A	7/1972	Springs	
3,925,994 A *	12/1975	Broms et al. ....	405/302.7
4,019,848 A	4/1977	Balhorn	
4,193,718 A	3/1980	Wahrendorf et al.	
4,616,959 A	10/1986	Hilfiker	
D296,007 S *	5/1988	Forsberg .....	D25/116
4,909,010 A	3/1990	Gravier	
4,914,876 A *	4/1990	Forsberg .....	405/286

**Reexamination Request:**

No. 90/007,279, Nov. 2, 2004

**Reexamination Certificate for:**

Patent No.: **5,294,216**  
 Issued: **Mar. 15, 1994**  
 Appl. No.: **07/651,322**  
 Filed: **Feb. 6, 1991**

**Related U.S. Application Data**

- (60) Division of application No. 07/534,831, filed on Jun. 7, 1990, now Pat. No. 5,062,610, which is a continuation-in-part of application No. 07/413,400, filed on Sep. 27, 1989, now abandoned, and a continuation-in-part of application No. 07/413,050, filed on Sep. 27, 1989, now abandoned.

(51) **Int. Cl.**

<b>B28B 7/16</b>	(2006.01)
<b>B28B 7/00</b>	(2006.01)
<b>B28B 17/00</b>	(2006.01)
<b>E04C 1/39</b>	(2006.01)
<b>E04C 1/00</b>	(2006.01)
<b>E04B 2/02</b>	(2006.01)

- (52) **U.S. Cl.** ..... **405/286; 52/604; 405/262**
- (58) **Field of Classification Search** ..... None  
See application file for complete search history.

(56) **References Cited**

**U.S. PATENT DOCUMENTS**

787,199 A	4/1905	Lloyd
1,905,975 A	4/1933	Thomas
2,313,363 A	3/1943	Schmitt
2,566,787 A	9/1951	Zevely
2,586,210 A	2/1952	Corwin
3,545,053 A	12/1970	Besser

**FOREIGN PATENT DOCUMENTS**

CH	630 134 A5	5/1982
CH	663437	12/1987

**OTHER PUBLICATIONS**

U.S. Copyright Registration TX 2 807 652 (3 pages), Keystone "Garden Walls" brochure, Mar. 20, 1989.  
 U.S. Copyright Registration TX 2 798 584 (3 pages), Keystone "Garden Walls" brochure, May 29, 1989.  
 Keystone brochure entitled "Beautiful Do-It-Yourself Results," Library of Congress, Jun. 27, 1988, 2 pages.  
 Drawing, bearing the date Mar. 22, 1989, entitled "Garden Unit".  
 Johnson Block Product documentation, 2 pages, "Retaining Wall System".

(Continued)

*Primary Examiner*—Peter C. English

(57) **ABSTRACT**

The present invention includes landscaping structures such as a retaining wall comprising a plurality of composite masonry blocks, the composite masonry block comprising a block body having an irregular trapezoidal shape and comprising a front surface and a back surface, an upper surface and a lower surface, and first and second sidewalls. Both the first and second sidewalls have a first and second part, the sidewall first part extends from the block front surface towards the block back surface at an angle of no greater than ninety degrees in relationship to the block front surface, the sidewall second part surfaces adjoins and lies between the sidewall first parts and the block back surface. The block also has a flange extending from the block back surface past the height of the block.

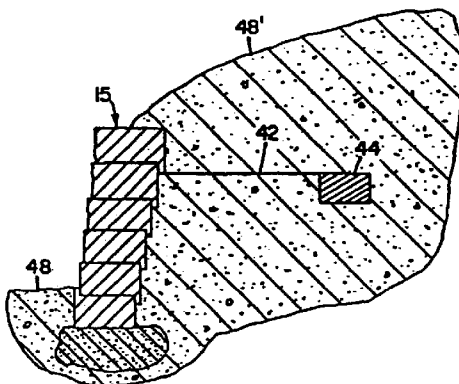

## OTHER PUBLICATIONS

“Keystone Retaining Wall Systems” Product Literature (1992), 12 pages.

Handy–Stone product literature bearing a copyright date of 1989, 3 pages.

A protest filed in U.S. Appl. No. 07/485,736, 10 pages.

A Petition to Make Special Because of Actual Infringement filed during prosecution of U.S. Patent 5,294,216, 2 pages.

A Declaration by Glenn Bolles filed during prosecution of U.S. Patent 5,294,216, 4 pages.

Rockwood E–Z Wall block brochure, 4 pages.

Summary of allegations as to date of publication of “Johnson Block” Product Literature, 3 pages.

Information regarding copyright notice on “Handy–Stone Retaining Wall System” Product Literature, 1 page.

Summary of allegations as to date of publication of “EZ Wall Ssystems” Product Literature, 1 page.

Alleged Johnson Block price lists received from Rockwood Retaining Walls in *Anchor Wall Systems, Inc. v. Rockwood Retaining Walls, Inc. et al.*, United States District Court, District of Minnesota, Civ. No. 99–CV–1356, 4 pages.

Deposition testimony of Mr. Richard Stehly, pp. 1 and 89, in *Anchor Wall Systems, Inc. v. Rockwood Retaining Walls, Inc. et al.*, United States District Court, District of Minnesota, Civ. No. 99–CV–1356.

Affidavit Of Richard D. Stehly, in *Anchor Wall Systems, Inc. v. Concrete Products of New London, Inc.*, United States District Court, District of Minnesota, Civ. No. 03–CV–3271, pp. 1 and 4.

Deposition testimony of Mrs. Therese Hovanec, pp. 1, 13–20 and 89–92, in *Anchor Wall Systems, Inc. v. Concrete Products of New London, Inc.*, United States District Court, District of Minnesota, Civ. No. 03–CV–3271.

An affidavit executed by Mr. Ray Price and two exhibits mentioned in the Price affidavit, from the matter *Anchor Wall Systems, Inc. v. Concrete Products of New London, Inc.*, United States District Court, District of Minnesota, Civ. No. 03–CV–3271, 7 pages.

Deposition testimony of Mr. Floyd Johnson, pp. 1, 60–63 and 70–71, in *Anchor Wall Systems, Inc. v. Concrete Products of New London, Inc.*, United States District Court, District of Minnesota, Civ. No. 03–CV–3271.

A sheet labeled “Flow Chart” that summarizes the series of patents and applications related to this patent, 1 page.

Print outs of photographs of Loffelstein blocks alleged to be dated as early as 1982, 1 page.

A memorandum from Gene F. Ernst to Paul Forsberg dated Oct. 6, 1987, 1 page.

The reply filed by Anchor Wall Systems, Inc. in response to the petition filed by Keystone Retaining Wall Systems, Inc. against Australian Petty Patent 650,230.

A decision by the Australian Intellectual Property Office in response to the petition filed by Keystone Retaining Wall Systems, Inc. against Australian Petty Patent 650,230.

An affidavit by Carl Moy submitted by Anchor Wall Systems, Inc. in response to the petition filed by Keystone Retaining Wall Systems, Inc. against Australian Petty Patent 650,230, Aug. 11, 1995, 6 pages.

An affidavit by Carl Moy submitted by Anchor Wall Systems, Inc. in *Anchor Wall Systems et al. v. Boral et al.*, Federal Court of Australia, Queensland District Registry, General Division, QG29 of 1995, Sep. 20, 1996, 15 pages.

An opposition filed by Keystone Retaining Wall Systems, Inc. opposing the issuance of Australian Patent Application No. 684,211.

Anchor Block Company/Oscar Roberts Concrete Products, Diamond Wall System Tech Spec, Sep. 1988, 2 pages.

Keystone Garden Walls, Beautiful Do–It Yourself Retaining Walls!, Mar. 1989, 1 page.

Declaration of Al Pfannenstien, Aug. 28, 1998, 5 pages.

\* cited by examiner



1

**EX PARTE  
REEXAMINATION CERTIFICATE  
ISSUED UNDER 35 U.S.C. 307**

THE PATENT IS HEREBY AMENDED AS  
INDICATED BELOW.

**Matter enclosed in heavy brackets [ ] appeared in the patent, but has been deleted and is no longer a part of the patent; matter printed in italics indicates additions made to the patent.**

AS A RESULT OF REEXAMINATION, IT HAS BEEN DETERMINED THAT:

Claims 1 and 13 are determined to be patentable as amended.

Claims 2–12 and 14–20, dependent on an amended claim, are determined to be patentable.

1. A retaining wall comprising at least a first lower course and a second upper course, each of said courses comprising one or more composite masonry blocks, each of said masonry blocks comprising:

(a) a block body, said block body comprising a front surface and a back surface separated by a distance comprising the depth of the block, an upper surface and a lower surface separated by a distance comprising the height of the block, and first and second sidewall surfaces adjoining said block upper and lower surfaces—both said first and second sidewall surfaces each comprising a first and second part, said sidewall first part surfaces extending from said block front surface towards said block back surface at an angle of no greater than ninety degrees in relationship to said block front surface, said sidewall second part surface adjoining and lying between said sidewall first parts and said block back surface; and

(b) a flange affixed to the block adjacent said rear surface and extending downwardly from said block body, said flange comprising a locking surface adapted to nest with the next lowest course of blocks, said locking surface extending downwardly from the plane of said block lower surface;

said wall further comprising at least one anchoring matrix interposed between a portion of at least [said] a first course block in said first course and a portion of at least [said] a second course block in said second course wherein the lower surface of said second course block is positioned on

2

top of the upper surface of said first course block, the block flange of said second course block being positioned adjacent and behind the block back surface of said first course block, wherein said anchoring matrix is distorted downwardly between said first course and said second course solely by the flange of one or more blocks in said second course [block flange], and wherein said matrix is fixed in position between the first and second courses solely by the distorted interposition of said matrix between blocks in said first and second [course blocks]courses and the weight [of] and frictional forces attributable to said second course and any other courses above said matrix.

13. A retaining wall comprising at least a first lower course and a second upper course, each of said courses comprising:

(a) one or more composite masonry blocks, each of said blocks comprising a block body comprising a front surface and a back surface separated by a distance comprising the depth of the block, an upper surface and a lower surface separated by a distance comprising the height of the block, and first and second sidewall surfaces adjoining said block upper and lower surfaces, said upper and lower surfaces adjoining said front and back surfaces, and said front and back surfaces adjoining said first and second sidewall surfaces, wherein each of said surfaces meet to form an edge and wherein at least [said] a second upper course block in the second upper course comprises a flange adjacent said second course block back surface extending downwardly from said second course block lower surface, said flange comprising a locking surface adapted to nest with an edge of a first lower course block in the [next] first lower course; and

(b) at least one anchoring matrix interposed between a portion of said first course block and a portion of said second course is positioned on top of the upper surface of said first course block, the back edge of said first course block being nested against the flange locking surface of said second course block, said anchoring matrix being distorted downwardly between said first course and said second course solely by the locking surface of one or more blocks in said second course [block], and said matrix being fixed in position between blocks in the first and second [course blocks]courses solely by the distorted interposition of said matrix between blocks in said first and second [course blocks]courses and the weight and frictional forces attributable to said second course and any other courses above said matrix.

\* \* \* \* \*