

(19)  
(12)

(KR)  
(A)

(51) 。 Int. Cl.7  
G02F 1/1333

(11)  
(43)

2003-0073122  
2003 09 19

(21) 10-2002-0012519  
(22) 2002 03 08

(71) 3 416

(72) 103 801

(74)  
:

(54)

2 4 1 2 1 2  
가 가 가 가 가 가  
, , , , , ,  
가 가 가 가 가 가

3

, , , , , ,

1

2 1

3

4 3

5 3

6  
7  
8 3  
9 3  
10 6 9  
11  
12 3 11  
13 10  
14 10  
15 5  
16 5  
17 PCB  
18

< >

110, 200 : 120, 310 :

133 : 134 :

140 : 150 :

160, 400 : 300 :

310 : 320 :

330 : 340 :

350 : 360 :

370 :

CRT

가

1

1

2 (140), (150) (100) (160) (110), (120), (130),  
 (130) (134), (133) (134)  
 (132a), PCB(312f), (312e, 132d)

(132b) (132) (132c) (가 )

(132c) ITO RGB 가

가 - (132b) 가 가

가 가

(134)가

(134) (134a) (134b) (134b), (134b) (134c, 134d),  
 (134e)

(134) (140) (140)

가

가

; ; 가 ;  
 , 4 ; 4

1

;

가

가

4

4

1

2

1

1

가

가

3

3

(300)

(400)

(200),

가 가

(200)

(400)

(300)

(360)

(300)

(310),  
(370)

(320),

(330),

(340),

(350),

(310)

(200)

(320)

e;

TCP)(323),

(320)

TCP(324)  
(321)

(

(322)

PCB  
( )

(Tape Carrier Packag  
) (325)

(322)

가

(ITO)

OFF)

가

가

- (Turn-ON)

- (Turn-

(322)

RGB 가

(321)

(321)

(321)

ITO

(322)

가

가

(414)

(412)

가

가

가

PCB(325) TCP(323) ,  
 TCP(324) 가 . ,  
 , TCP(323) PCB(325) TCP(324) .  
 , PCB(325) PCB PCB PCB PCB  
 (wire bonding) (bumping) 가 (COG; Chip On Glass)  
 , TCP(324)가 ( ) 가 TCP(323)가 ( ) 가  
 PCB(325) TCP(324) . 가  
 PCB(325) ( ) 가  
 가  
 , PCB(325) 가 , TCP(324) TCP(323)  
 가 . 가 , TCP(324) , TCP(323)  
 (330) (320) , (320) , (360) ,  
 (370) . (340), (350)  
 (340) (350) .  
 4 .  
 (350) 1 2 (352, 354) (340)  
 (354) (320) , 1 (352) 2  
 (350) , ,  
 , 1 2 (352, 354) (370) . 1  
 2 (352, 354) (370)  
 1 2 (352, 354) (370) (370)  
 , 5 .  
 (360) (350) .  
 (370) (340) (340) (350)  
 (370) (340), (350) (360) (350) (330) ,  
 가 (370) , (352, 354)

4 3

3 4 (340) (350) (342, 344, 346)가 (370) (342, 344, 346) (342a, 344a, 346a)

(342, 434, 346) (340) 가 (340) (340)

5 3

3 5 (350) (320)

(350) 가 (350) 가

(flat) (wedge) 가

(350) 'ㄷ' 가 (350a, 350b) (350) (370) 가

2 가 (370)

(350) (352, 354) ( ) (350) , 1 2

(350) 3 (360) (360) 1 2 (350a, 350b)

(352, 354) , 가 (360) (350) 가 (350a, 350b)

(350) (340) (350) (340) (350) 가

6 , 7 3

6 (360), (350) (370) 4 (340)

(370) 4 1 2 (510, 520)

(370) 3 4 (530, 540) , 5

가 (370) 1 (510) 2 (520) (350) 가 (350a, 350b)

가 (350a, 350b) 1 2 (510, 520) (350)

가 1 2 (2510, 2520)가

12) , 1 (2512) (2510) 1 (510) (350) 1 (25) , 1 (370) (2518) 3 (2516) 2 (2514) , 1 2 (2512, 2514) , 3 (2512, 2514, 2516) (350) .

2 , 2 (2512) (2520) 2 (520) (350) 4 (2522) , 370 (2528) 6 (2526) 5 (2524) , 4 5 (2522, 2524) , (350) 6 (2522, 2524, 2526) (350) .

1 2 (2510, 2520) 1 2 (510, 520) 가 (350) , 1 (2510) (370) (350) 가 (350a) .

(332) (350) , (350) 1 (2512a) (330) 3 가 (350) , 가 (350) (350) 가 (350) .

2510) (370) 1 (2510) (330) 16 (370) 1 ( 가 (420a)가 가 (350a) , 가 )

(1421, 1422) , 1 (330) 3 (332) (330) 1 2 (1421) 2 (1422) 3 (1423) , 3 (1423) (330) 4 (1424) , 4 (1424) 5 (1425) , 5 (1425) 3 (1423) 6 (1426) .

(2510) 가 , (330) 3 (332) (370) 1 8 3 .

3 8 (340) (330) (370) , (320) (320) ,

0b, 530a, ..., 530d, 540a, ..., 540d) 6 (370) (510a, 510b, 520a, 52 (330a, ... , 330i)가 (330) (330) (330a, ... , 330i) ( 370) (510a, 510b, 520a, 520b, 530a, ..., 530d, 540a, ..., 540d) (370) (370) (340), (350) (360) (370)

1 (330) 6 (370) 1 2 (2510, 2520) 가 1 2 (2510, 2520) 가 (350a, 350b) , 3 (332, 334)가 . 9 3 (332)

9 3 .

9 1 (2510) 가 (440a) (370) (370) 1 (2510) 3 (332)가 . 가 가

(1421, 1422) , 1 (330) 3 (332) (330) 1 2  
 (1421) 2 (1422) 3 (1423) , 3 (1423)  
 (330) 4 (1424) , 4 (1424) 5 (1425) , 5  
 (1425) 3 (1423) 6 (1426)

(2510) 가 , (330) 3 (332) (370) 1  
 , 4 (334)

10 6 9

6, 9, 10 (330) (370)가 (330) 3 (3  
 32) (370) 1 (2512a) (350) 가 (440a) 1 (25  
 12a)

, (370) 1 (2512a) (t1) (330)  
 3 (332) (t2) (360), (350) (340)  
 , (350) 가 (370)  
 (2512) (330) 3 (332) , 1 가  
 (350) 가 (440a)

, (600) (370)가 , 1 2 (2512a)가 (350) 가  
 (440a) (350) (370) (350)

11 , 12  
 , 6

3 11, 12 (370) 1 (510) 2 (520) (350)  
 가 (350a, 350b) (350) 가 'ㄷ'  
 1 2 (512, 522)가 1 2 (512, 522) (350)  
 가 (350a, 350b) (370) (350)  
 , 1 2 (510, 520) 2 가  
 , 2

512a) , 1 (512) 1 (510) , (350) 1 (  
 , 1 (510) 2 (512b) , 1 2 (512a, 512b)

, 2 (522) 2 (520) (350) 4 (522a) ,  
 2 (520) 5 (522b) , 4 5 (522a, 522b) , 2  
 (520) 6 (522c) , (350)

(370) 1 4 (510, 520, 530, 540) (510a, 510b, 520a, 520b, 530a,  
 ..., 530d, 540a, ..., 540d) , (330) (370) (340),  
 (350) (360)

, (370) 1 (510) 2 (520) 4 (370)  
 (340) (432) (432a) 1 2  
 (510, 520) (514, 524, 525)

, (350) (370) (512, 522) (350) 가 (350a, 350b)  
 (370) , (350) 가 가  
 , (350) (340) 가





(330) TCP(323) (330)  
 (Rib) TCP(323)가 (330)  
 (200) (200) (300) (320)  
 (330)  
 17 14 PCB (a) PCB (b)  
 (330) PCB(325)가 PCB (370)  
 17 PCB (700) PCB(325)  
 (370) 1 (552, 554, 556) (710, 720, 730)  
 13 17 (370) 1 (552, 554, 556) PCB(325)  
 418a, 418b, 418c) 2 (418a, 418b, 418c) PCB(325) 2 (370)  
 5) (370) 1 (552, 554, 556) 1 2 PCB(325) PCB(325)  
 PCB(325)가 (370) (350)  
 18 6  
 6 18 (370) 1 (510) 2 (520) (350)  
 가 'ㄷ' (350a, 350b) 1 2 (510, 520) (350)  
 가 1 2 (1512, 1522)가  
 1 2 2 가  
 2  
 (1512a) 1 (1512) 1 (510) (350) 1  
 (510) 1 (510) 2 (1512b) 1 (1512a) 1  
 (1512c) 2 (1512b) 1 (510) (1512d)  
 2 (1522) 2 (520) (350) 5 (1522a)  
 2 (520) 6 (1522b) 5 (1522a) 2 (520)  
 7 (1522c) 6 (1522b) 2 (520) 8 (1522d)  
 1 2 (1512, 1522) 가 (1512e, 1522e)가  
 (1512, 1522) (1512e, 1522e) (370)  
 (1512, 1522)  
 (370) 1 (510) 2 (520) (370)  
 340) (432) (432a) 1 2 (510,520)  
 (514,515,524,525)가  
 (370) (340) (514,515,524,525) (362a,362b,362c)  
 (370) 1 (510) 2 (520) 가 (432)  
 (340)  
 4 (370) 1 (512) 2 가  
 (340) 가

(340)

3 12

1 (352) 2 (354) (370) (540)

12, 522) (370) (360) 가 (350) (370) (5  
 가 (350a, 350b) (350) (370) (512, 522)  
 (350a, 350b) (360) (350) (350)

434a. 436a) (340) (370) (514, 524, 525) (340) (432a.  
 (432, 434, 436) 가 (350) (340) (340)  
 ) (514, 524, 525) (432a. 434a. 436a) (340)

525) (340) (370) (514, 524,  
 (432a. 434a. 436a) (340) (370)

(370) A/D ( ) ( )가

(370) (330) (360), (350) (340)  
 (370) (330) (420a, ... , 420I)가 (370) (510a,  
 510b, 520a, 520b, 530a, ..., 530d, 540a, ..., 540d) (370)

(330) (320) (320)  
 (300) (330) TCP(417) (370)  
 PCB(418) (330)

(370) PCB(418) PCB (700) PCB(418)

(330) (330) (370) (300)

3 (370) (300) (200)가 (200)  
 (400)가 가

(PDP) EL , PCB  
 가 가



1 , 1 2

10.

1 , 1 , 1 ;  
2 ;  
1 2 , 3 .

11.

1 , 1 , 1 ;  
2 ;  
1 , 3 ;  
2 , 4 .

12.

1 , , , .

13.

12 1 가 , 1 , 2 .

14.

13 , 1 2 .

15.

;  
 ;  
 가 ;  
 가 ;  
 4 , 4 , 1 ;  
 1 , 1 , 2

15 16.

1

15 17.

1

15 18.

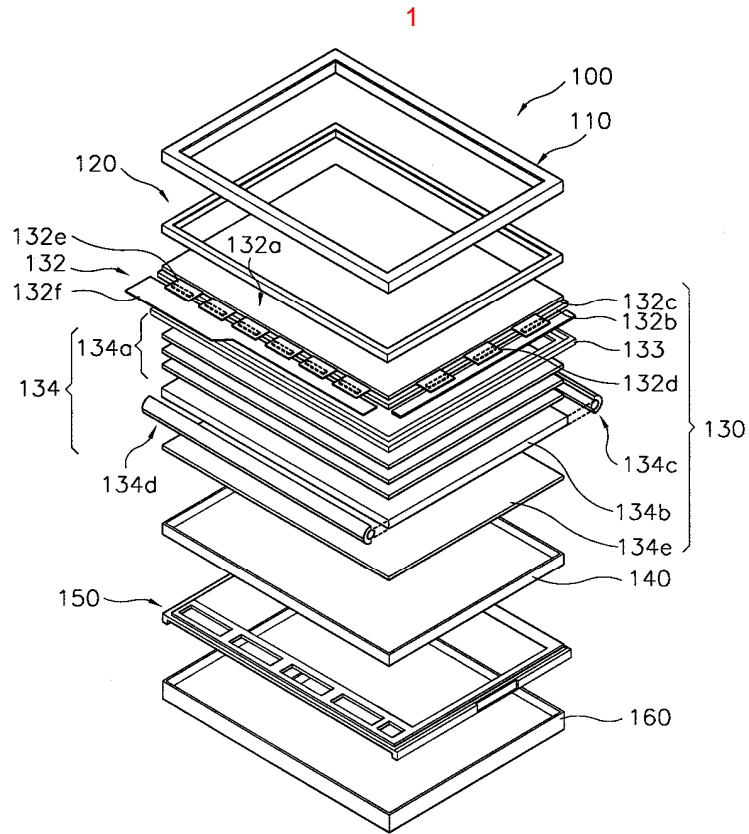

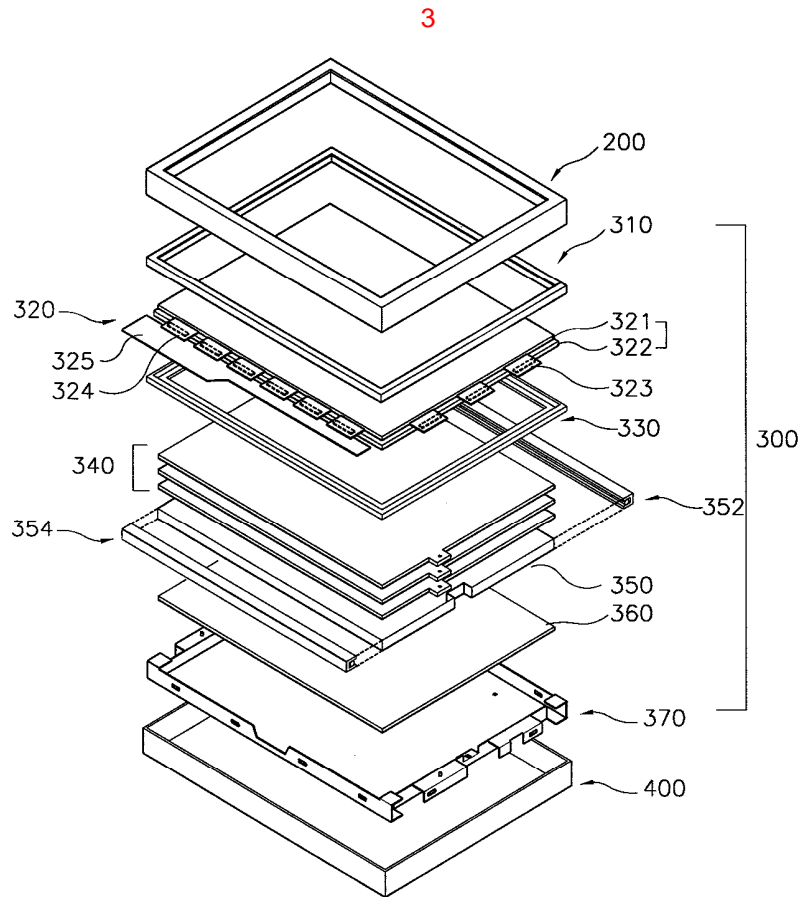
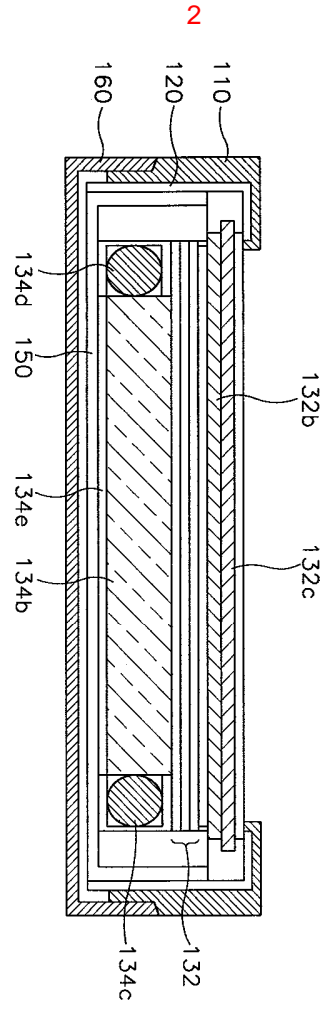

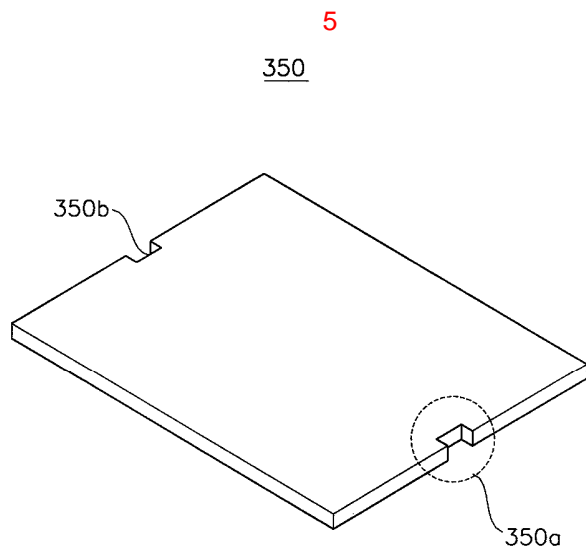
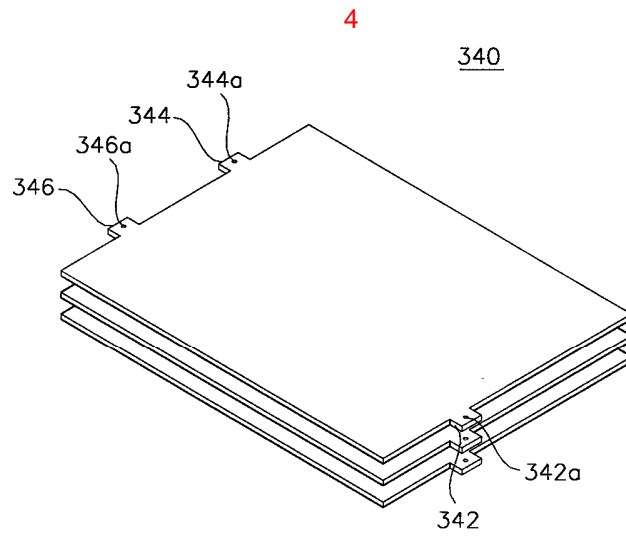



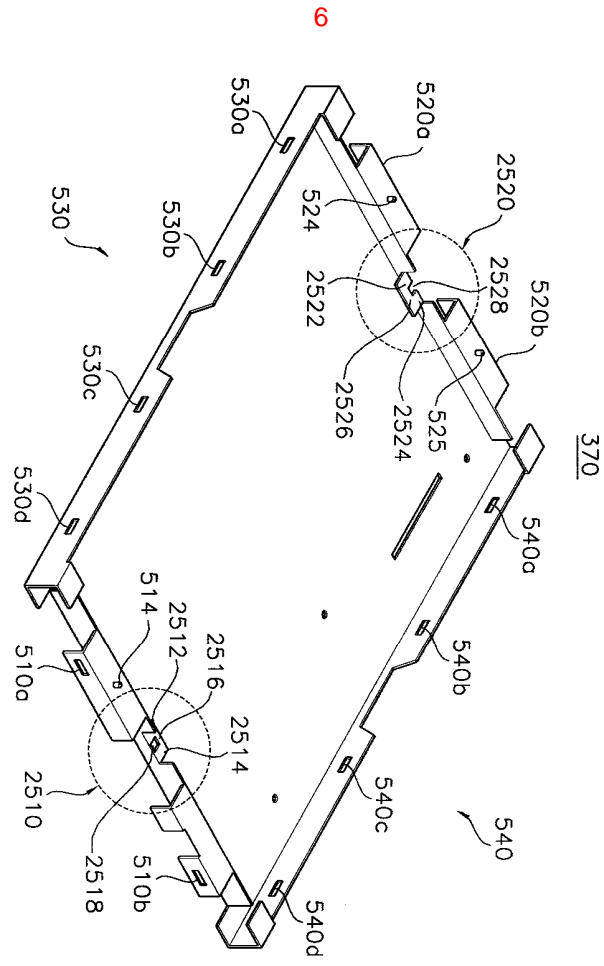

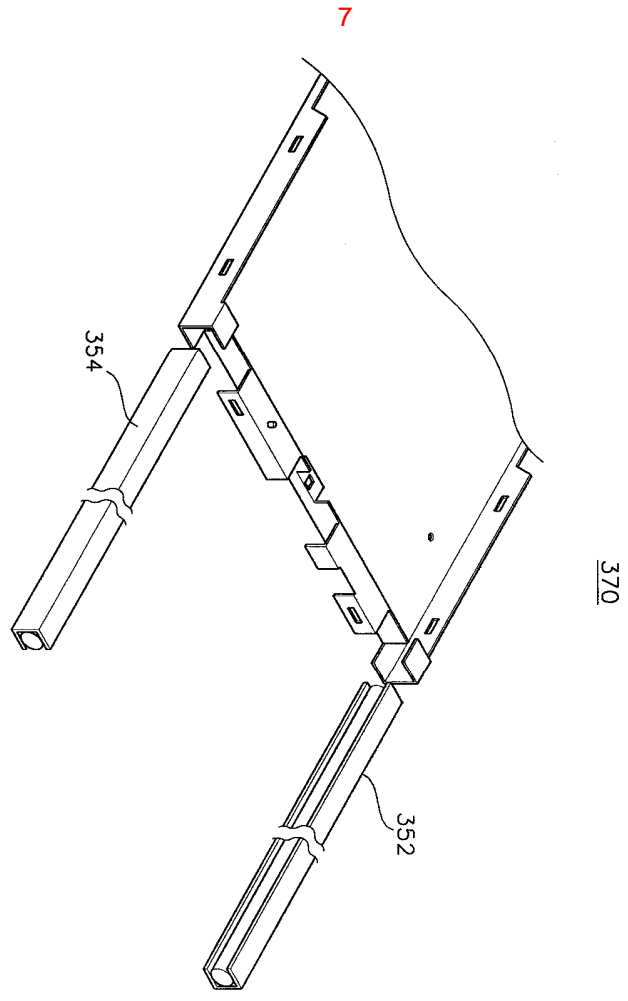

8

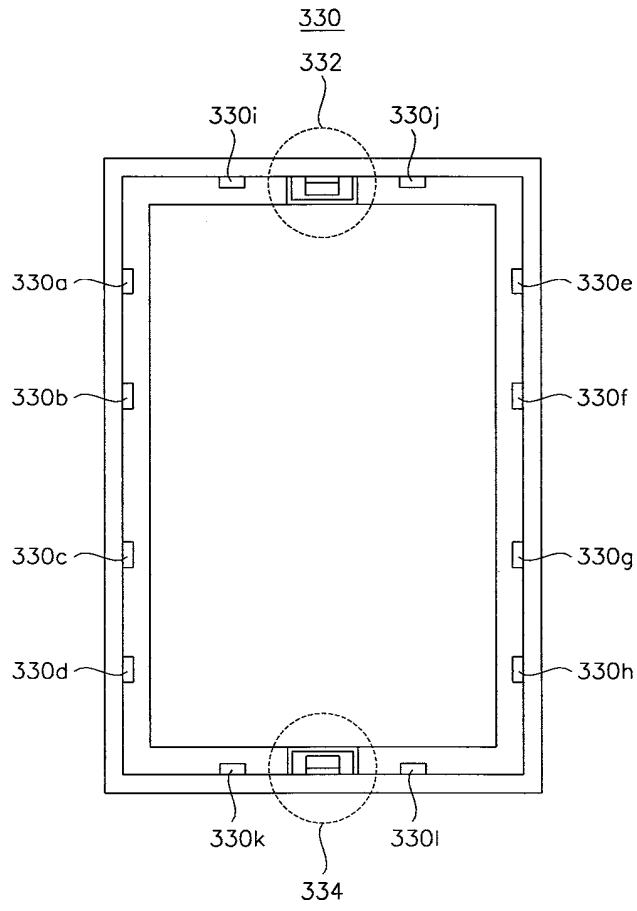

9

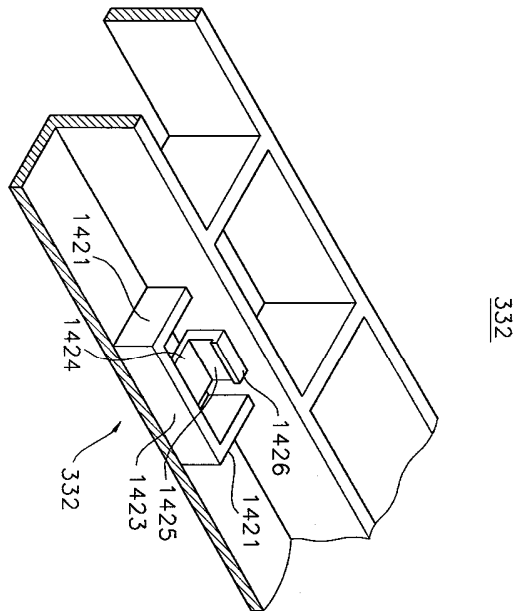

10

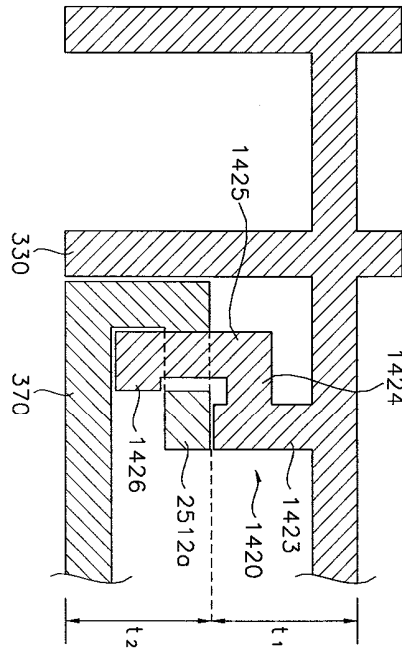

11

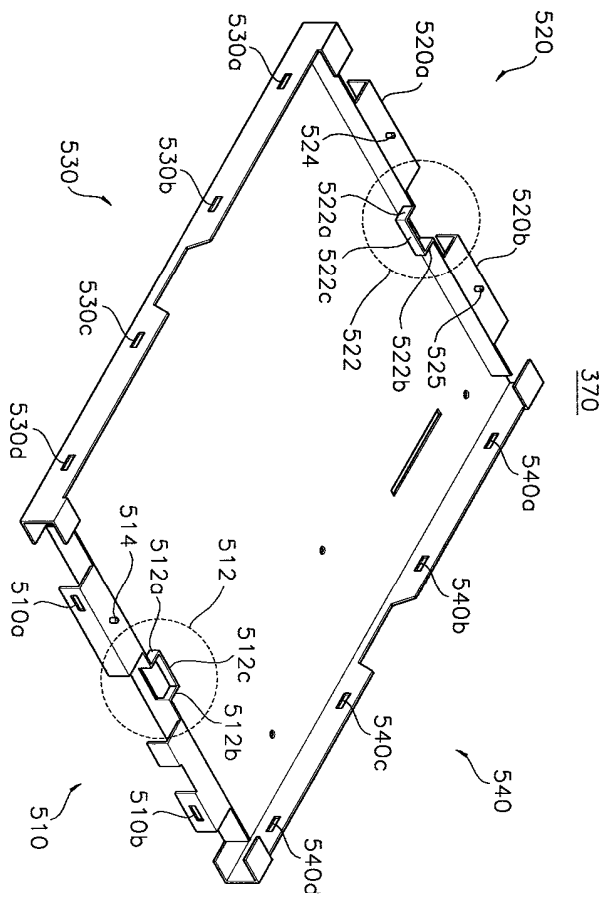

12

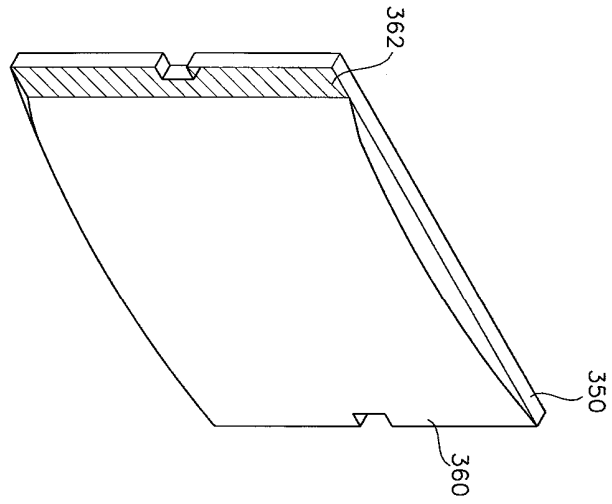

13

(a)

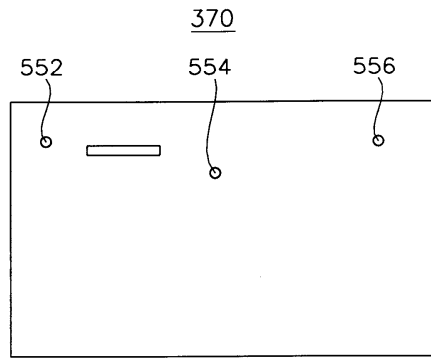

(b)

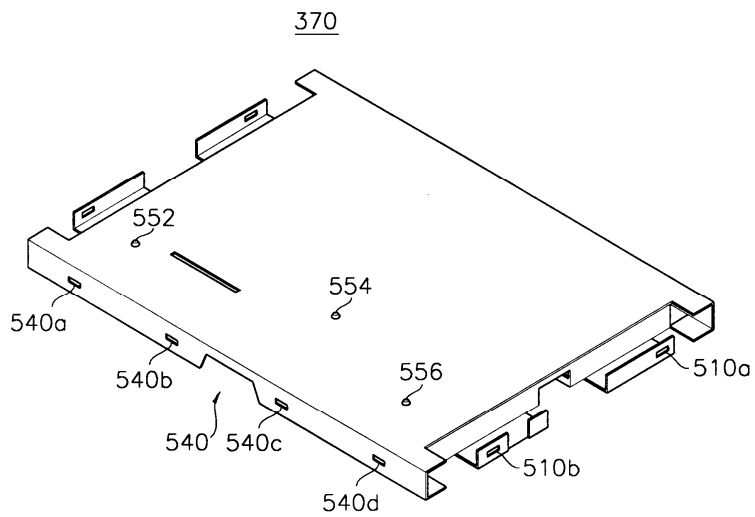

14

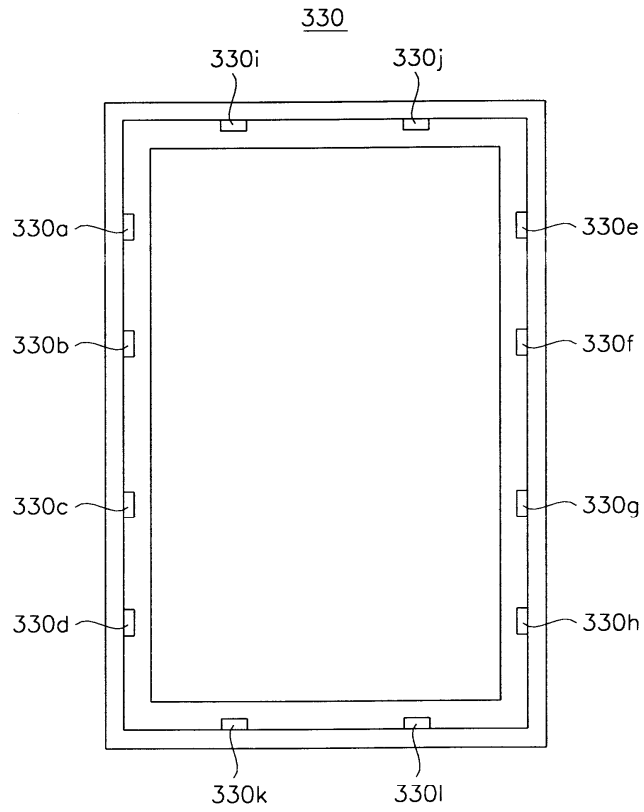

15

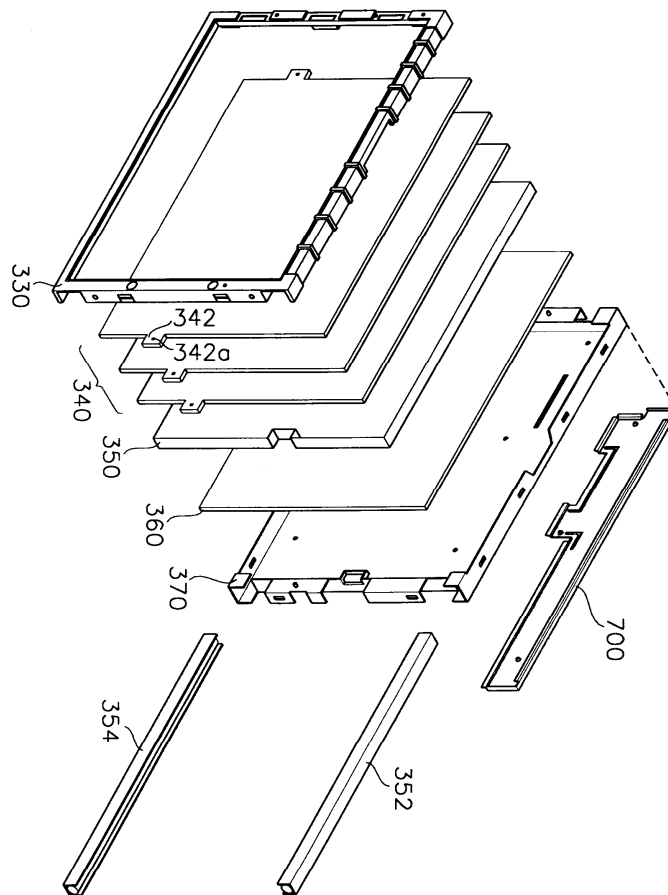

16

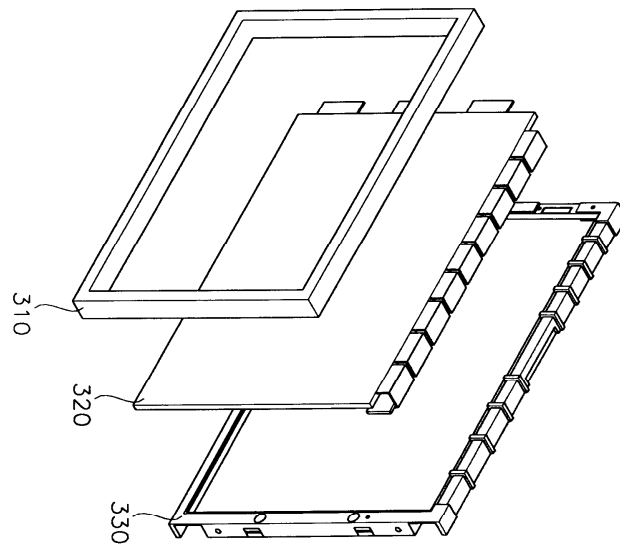

17

(a)

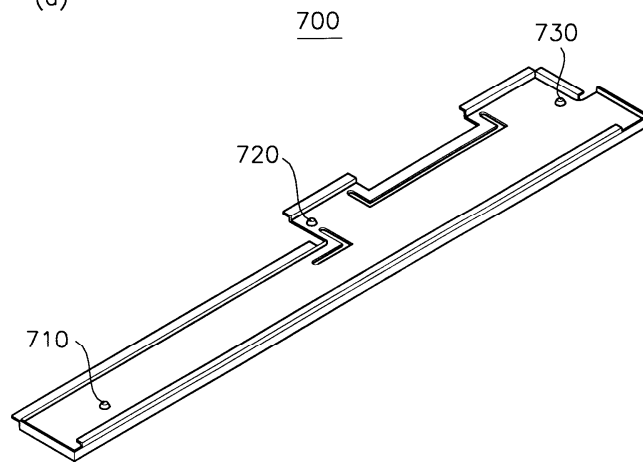

(b)

