

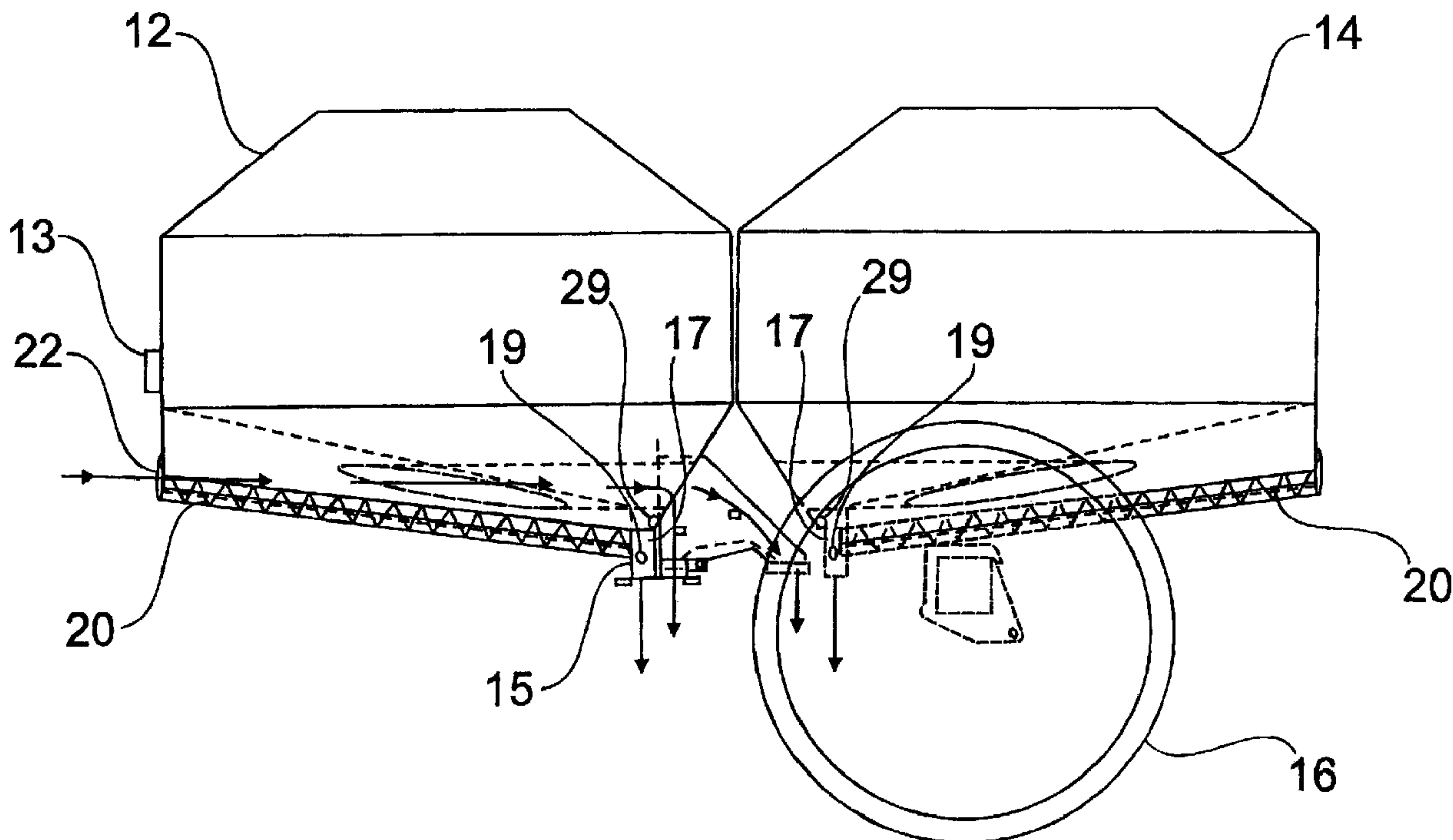

(22) Date de dépôt/Filing Date: 2003/03/26  
 (41) Mise à la disp. pub./Open to Public Insp.: 2004/04/15  
 (45) Date de délivrance/Issue Date: 2008/01/29  
 (30) Priorité/Priority: 2002/10/15 (US10/270,457)

(51) Cl.Int./Int.Cl. *A01C 7/16* (2006.01)  
 (72) Inventeur/Inventor:  
 MEMORY, RUSSELL J., CA  
 (73) Propriétaire/Owner:  
 CNH CANADA, LTD., CA  
 (74) Agent: GOWLING LAFLEUR HENDERSON LLP

(54) Titre : VIS SANS FIN DE RESERVOIR INTERIEUR POUR TREMIERS DE SEMOIR PNEUMATIQUE  
 (54) Title: INTERNAL TANK AUGERS FOR AIR SEEDER HOPPERS



(57) **Abrégé/Abstract:**

An air seeder is provided having at least one container with a trough in the bottom floor. Preferably, the floor is formed with a v-shaped configuration converging at a metering mechanism. An auger is rotatably mounted in the trough to move particulate material to the metering mechanism located at a distal end of the container. The auger is powered by a motor mounted on the distal end of the auger opposite the metering mechanism. A remote fan mechanism is provided to deliver a supply of air to the metering mechanism through a pair of conveying tubes. Optionally, a sensor is provided to control the operation of the auger so that the auger only operates when it is needed.

**INTERNAL TANK AUGERS FOR AIR SEEDER HOPPERS****ABSTRACT OF THE DISCLOSURE**

[0044] An air seeder is provided having at least one container with a trough in the bottom floor. Preferably, the floor is formed with a v-shaped configuration converging at a metering mechanism. An auger is rotatably mounted in the trough to move particulate material to the metering mechanism located at a distal end of the container. The auger is powered by a motor mounted on the distal end of the auger opposite the metering mechanism. A remote fan mechanism is provided to deliver a supply of air to the metering mechanism through a pair of conveying tubes. Optionally, a sensor is provided to control the operation of the auger so that the auger only operates when it is needed.

**TITLE OF INVENTION****INTERNAL TANK AUGERS FOR AIR SEEDER HOPPERS****FIELD OF THE INVENTION**

[0001] The present invention relates generally to an agricultural implement, such as an air cart forming part of an air seeding implement for planting seed and fertilizer into the ground. In particular, the present invention relates to the use of augers in low incline air seeder tanks to transfer product such as seed or fertilizer to a metering mechanism for disposition to the ground.

**BACKGROUND OF THE INVENTION**

[0002] Air carts for use on agricultural implements are well known. Typically, these air carts are used as part of an air seeder in which seeds, fertilizer and herbicides are deposited onto and into the ground during the planting operation. Air seeders and other seeding devices are commonly towed by tractors to apply seed or fertilizer, or both simultaneously, to a field. For example, an air seeder may be towed in combination with a tilling implement, one behind the other, to place the seed and fertilizer under the surface of the soil. Generally, air carts are in either a two container or three container configuration. The two container configuration is used to carry a supply of seeds and fertilizer for planting into the ground. The three container configuration can be used to carry an

additional element, such as an herbicide, to be deposited on the ground. The three container configuration, however, can also be used to carry only one or two materials in whatever amounts are desired.

[0003] Air seeders also typically include a metering system for dispensing product from the tanks and a pneumatic distribution system for delivering the product from the tank to the soil. The tanks of the air seeders are formed with bottom surfaces that slope downward at the angle of repose for the product toward the metering mechanism. Gravity, in combination with the vibrations and movement of the air seeder, act to move the grain from the perimeter of the tank toward the metering mechanism located at the center of the tank.

[0004] Such movement of the product can be inefficient, and seed and/or fertilizer is often left behind when the volume in the tank becomes low. While this small amount of seed/or fertilizer does not substantially interfere with the ongoing operations of the air seeder, the seed or fertilizer that is left in the grain tank over extended periods of time, such as during storage of the air seeder between seasons, will likely spoil. This spoiled product will then be discharged from the air seeder the next time it is used, leading to contamination of the newly added product. Moreover, the spoiling or rotting process of the seed or fertilizer in the air seeder tank can be corrosive to the air seeder. Over time, the air seeder tank can be damaged and require repair. Additionally, any product that is left in the tank when the tank is switched to a different product will exit the air seeder with that new product. For example, if the tank has been used to dispense fertilizer, fertilizer

will remain in the tank and will be intermingled with, for example, seeds when the tank is next used. This could be damaging to the seeds. Moreover, operators of air seeders demand that almost all product drain evenly from the tank with each use so that greater field efficiency can be achieved.

[0005] Further, it is desirable to increase the volume of the air seeder hopper so that more ground can be covered without having to stop and re-fill the tanks. However, if larger tanks are employed, the air seeder becomes unstable due to an excessive center of gravity. Additionally, in a large capacity two tank system, the optimal design would typically place the rear metering mechanism rearward over the axle. However, this causes interference both with clean out and with the location of the metering mechanism in a gravity fed tank. In order to translate the slopes and drain the tanks to one metering location, the tanks must be moved forward, thereby increasing the frame length and making the tanks even more unstable.

[0006] Accordingly, it would be desirable to provide a large capacity air seeder hopper which can carry a large volume of product and efficiently transport the product to the metering mechanism and overcome the aforementioned disadvantages of the current state of the art.

## SUMMARY OF THE INVENTION

[0007] Accordingly, an important object of the present invention is to provide an auger for use in air seeder tanks to transfer particulate material such as seed or fertilizer to a metering mechanism for disposition to the ground.

[0008] It is another object of the present invention to provide an auger located along a trough incorporated into the bottom floor of the tank of the air seeder.

[0009] It is yet another object of this invention to locate the rear tank metering mechanism forward of the rear axle and in close proximity to the metering mechanism of the front tank.

[0010] It is a further object of the present invention initiation to provide sensors to indicate the grain level within the tanks or to sense a shortage of grain at the metering mechanism.

[0011] It is another object of the present invention provide a compact tank design to limit the physical tank size.

[0012] It is yet another object of this invention to provide motors to individually power each auger.

[0013] It is a further object of the present invention to reduce hopper depth.

[0014] It is an advantage of the present invention that the center of gravity in the tank is lowered, which stabilizes the air seeder.

[0015] It is another advantage of the present invention that the augers transfer the particulate material to the metering mechanisms only when required.

[0016] It is a further advantage of the present invention that the individual augers can be lifted to provide for a fast and easy cleanout.

[0017] It is a feature of the present invention that the floor of each individual tank is formed with a v-shaped configuration that converges into the metering mechanism.

[0018] It is another feature of this invention that the individual containers can be molded from noncorrosive plastic or single sheet metal.

[0019] It is yet another feature of the present invention that the slope of the floor of the individual tanks is shallow.

[0020] It is a further feature of this invention that the augers can be initiated in a response to a lowered torque as the particulate material drains from the flightings.

[0021] It is another feature of the present invention that the metering mechanisms are not centered on each tank.

[0022] It is still another feature of this invention to provide containers for an air seeder that are durable in construction, inexpensive to manufacture, easy to maintain, and simple and effective in use.

[0023] These and other objects, features, and advantages are accomplished according to the present invention by providing an air seeder having a frame, a pair of ground engaging wheels, a metering mechanism, and at least one container having at least one trough incorporated into the bottom floor with an auger

rotatably mounted in each of the troughs for transporting particulate material along the floor of the container to the metering mechanism.

[0024] The foregoing and other objects, features, and advantages of the invention will appear more fully hereinafter from a consideration of the detailed description that follows, in conjunction with the accompanying sheets of drawings. It is to be expressly understood, however, that the drawings are for illustrative purposes and are not to be construed as defining the limits of the invention.

### **BRIEF DESCRIPTION OF THE DRAWINGS**

[0025] The advantages of this invention will be apparent upon consideration of the following detailed disclosure of the invention, especially when taken in conjunction with the accompanying drawings wherein:

[0026] Fig. 1 is a side elevational of a prior art air seeder mechanism of a general type in which the principles of the present invention can be incorporated;

[0027] Fig. 2 is an enlarged partial side elevational view of an air seeder hopper incorporating the principles of the present invention, portions of the frame and hitch being removed for purposes of clarity;

[0028] Fig. 3 is a partial front elevational view of the air seeder hopper corresponding to Fig. 1;

[0029] Fig. 4 is a partial underside perspective view of the air seeder hopper corresponding to Figs. 2 and 3;

[0030] Figs. 5a-5g are schematic perspective views of the hopper;



[0031] Fig. 6 is a partial perspective view of an air seeder hopper showing the location of an optical sensor;

[0032] Fig. 7 is a schematic elevational view of an air seeder hopper illustrated in Fig. 2 showing the auger in a working position; and

[0033] Fig. 8 is a schematic elevational view of an air seeder hopper illustrated in Fig. 2 showing the auger in a clean out position.

### DETAILED DESCRIPTION OF THE PREFERRED EMBODIMENTS

[0034] Referring now to Figs. 1 - 4, the details of an air seeder hopper incorporating the principles of the present invention can best be seen. The air cart 10 preferably has a large capacity tank 11 of one or preferably two container configuration. The two individual containers 12, 14, as shown in Figs. 2 - 4, are mounted on a frame mechanism 15 which is supported by ground engaging wheels 16 for mobile movement over the ground. Each container 12, 14 is preferably formed from molded plastic and is capable of being pressurized. Preferably, each container 12, 14 is capable of being pressurized at a different operating pressure from the other container. Furthermore, each container 12, 14 must be capable of operating under different levels of fullness. For example, fertilizer in one container and seed in another container will not necessarily empty at the same rate, particularly for different types of seeds that can be planted.

[0035] Each container 12, 14 is provided with a metering mechanism 15 of generally conventional configuration, but positioned near a distal end of the

container. Because of the large capacity of the container, and the requisite positioning of the metering mechanism 15 at the interior end of the container, so as to be positionable adjacent of the metering mechanism of the opposing container near the center of the tank, the slope of the floor of the individual containers 12, 14 is shallow, or even flat. To move particulate material, such as fertilizer or seed, within the container to the metering mechanism 15, an auger 20 is located along a trough 18 incorporated into the bottom floor of the individual container 12, 14.

[0036] A supply of air from a remote fan mechanism as represented in Fig. 1 can be delivered to the metering mechanism 15 by conveying tubes 22 that can pass at least partially internally of the individual container 12, 14, as is shown in Figs. 2 and 3. Preferably the air supply for both metering mechanisms for the two containers 12, 14 will come from a single fan mechanism (not shown) and be distributed to appropriately placed conveying tubes 22 to receive particulate material delivered through the metering mechanisms 15 for conveyance thereof to the planters as shown in Fig. 1. Since both containers 12, 14 are commonly manufactured, the conveying tubes 22 may be present in the rear container 14, although not be connected to a fan mechanism to provide a supply of air.

[0037] As is best seen in Figs. 3, 4 and 5a-5g, the floor of each individual container is formed with a double v-shaped configuration converging into the metering mechanism 15. At the lower apex of each v-shaped configuration, a trough 18 is provided in which an auger 20 is rotatably mounted to convey grain

or other particulate material along the bottom of the floor into the metering mechanism 15. Preferably, there is an auger 20 located in each of the troughs 18 in the containers 12, 14. The v-shaped configuration of the floor facilitates the movement of particulate material into the auger 20 for conveyance to the metering mechanism 15. As is best seen in Figs. 4, 7 and 8, each auger 20 is individually powered by a motor 21 mounted on the distal end of the auger 20 compared to the metering mechanism 15. Preferably, these motors are hydraulically driven; however, they could be driven electrically or pneumatically as well.

[0038] Preferably the floor of the container is sloped toward the metering mechanism 15 from the distal end thereof to enable a gravity flow of product within the container into the metering mechanism 15. The augers 20 in such a configuration will be utilized only to convey product within the container as a result of insufficient gravity flow into the metering mechanism. Thus, the augers 20 are rotated by the motors 21 only when required to convey product into the metering mechanisms 15.

[0039] To control the operation of the individual augers 20, a sensor 19 is incorporated into a product supply box 17 forming part of the metering mechanism 15. When the sensor 19 indicates a shortage of product to be dispensed through the metering mechanism 15, a controller 13 initiates rotation of the motors 21 to convey product from the hopper into the product supply box 17 of the metering mechanism 15, thus filling the metering mechanism 15 as needed to maintain

proper operation thereof. When a sufficient supply of product is present in the metering mechanism 15, the sensor 19 stops the rotation of the auger 20.

[0040] Alternatively, as illustrated in Fig. 6, initiation of the drive of the augers 20 can be the response of a signal from an optical sensor 29 indicating the grain level within the container or by sensing lowered torque requirements to effect rotation of the auger as grain, or other products, drains from above the flightings of the augers.

[0041] Although the slope of the container 12, 14 and the use of augers 20 removes most of the particulate material from the containers 12, 14 during operation, some residual particulate material remains in the tank. As shown in Fig. 7, when the auger 20 is in the working position, the auger 20 is located at the bottom of trough 18. However, as illustrated in Fig. 8, to completely clean out the containers 12, 14, the augers 20 are lifted at the non-driving end and the containers 12, 14 are manually swept clean.

[0042] In a preferred embodiment, the augers 20 are released by an easy release mechanism 30, as illustrated in Figs. 6 - 8. The easy release mechanism 30 includes a u-shaped bracket 31 having a pair of upwardly extending arms with holes therein to receive a pin 33. When the pin 33 is inserted through the holes, the easy release mechanism 30 is in a closed and locked position. As a result, the auger 20 remains placed in the trough 18 in the working position. To clean out the containers 12, 14, the operator simply removes the pin 33 from the u-shaped bracket 31 and raises the auger 20 for manual clean out as described above.

[0043] The invention of this application has been described above both generically and with regard to specific embodiments. Although the invention has been set forth in what is believed to be the preferred embodiments, a wide variety of alternatives known to those of skill in the art can be selected within the generic disclosure. The invention is not otherwise limited, except for the recitation of the claims set forth below.

Having thus described the invention, what is claimed is:

1. In an air seeder having a frame, a pair of ground engaging wheels, at least one container having an outer end wall, an opposite inner end wall, and side walls connecting the outer end wall and the opposite inner end wall, and a metering mechanism for dispensing particulate product from said at least one container, the improvement comprising:

said at least one container having a trough incorporated into a bottom floor and an auger rotatably mounted in said trough for transporting said particulate material along said floor to said metering mechanism.

2. The air seeder of Claim 1, further comprising a motor mounted on a distal end of said auger relative to said metering mechanism to rotate said auger and convey said particulate material to said metering mechanism.

3. The air seeder of Claim 2, wherein said metering mechanism is located at an end of said container.

4. The air seeder of Claim 3, wherein said floor is shaped in a v-shaped configuration converging at said metering mechanism.

5. The air seeder of Claim 4, wherein said container is formed in a double v-shaped configuration to facilitate movement of particulate material into the auger for conveyance of said particulate material to said metering mechanism.

6. The air seeder of Claim 5, wherein said trough is located in a lower apex of each of said v-shaped configurations, each said trough having an auger rotatably mounted therein for transporting said particulate material along said floor to said metering mechanism.

7. The air seeder of Claim 3, further comprising:  
a sensor in said metering mechanism to detect a shortage of said particulate material being dispensed through said metering mechanism, and  
a controller to initiate rotation of said auger to convey particulate material from the container to fill said metering mechanism.

8. The air seeder of Claim 7, wherein said sensor stops said motor when a sufficient amount of said particulate material is present in said metering mechanism.

9. The air seeder of Claim 3, further comprising an optical sensor located in said container to sense a level of particulate material within said container, said optical sensor triggering the start of said motor and subsequent

rotation of said auger to deliver said particulate material to said metering mechanism.

10. The air seeder of Claim 3, further comprising a fan mechanism and a pair of conveying tubes that pass at least partially internally of said container for delivering air to said metering mechanism.

11. The air seeder of Claim 10, wherein said container is formed of molded plastic.

12. The air seeder of Claim 1, wherein said air seeder includes a first container having a first metering mechanism and a second container having a second metering mechanism, said first metering mechanism being located in close proximity to said second metering mechanism.

13. The air seeder of Claim 3, wherein said auger is initiated in response to lowered torque to effect rotation of said auger as said particulate product drains from said container.



14. An air seeder comprising:
- a frame,
  - a pair of ground engaging wheels,
  - a first container having an outer end wall, an opposite inner end wall, and side walls connecting the outer end wall and the opposite inner end wall,
  - a second container having an outer end wall, an opposite inner end wall, and side walls connecting the outer end wall and the opposite inner end wall,
  - a first and second metering mechanism for distributing particulate material to the ground, said first metering mechanism being located in close proximity to said second metering mechanism,
  - a trough incorporated into a bottom floor of each of said first and second containers,
  - an auger rotatably mounted in each said trough for transporting said particulate material along the corresponding said floor to the corresponding said metering mechanisms, and
  - a motor for rotating each respective said auger to convey said particulate material to the corresponding said metering mechanism, each said motor being initiated only when required to convey said particulate material to the respective said first and second metering mechanisms.

15. The air seeder of Claim 14, wherein said floor of said first and second containers is shaped in a v-shaped configuration converging at said first and second metering mechanisms respectively.
16. The air seeder of Claim 14, further comprising a fan mechanism and a pair of conveying tubes that pass at least partially internally in at least one of said containers for delivering air to said metering mechanisms.
17. The air seeder of Claim 15, wherein said first and second containers are formed in a double v-shaped configuration to facilitate movement of particulate material into said auger for conveyance of said particulate material to said first and second metering mechanisms.
18. The air seeder of Claim 17, wherein said troughs are located in a lower apex of each of said v-shaped configurations, each said trough having an auger rotatably mounted therein for transporting said particulate material along said floor to said metering mechanism.
19. The air seeder of Claim 14, wherein said initiation of said motor occurs when a sensor located in each of said first and second metering mechanisms detects a shortage of said particulate material to be dispensed through the respective said first or second metering mechanism.

20. The air seeder of Claim 14, wherein each said container includes an optical sensor to detect a level of particulate material within the respective container, said initiation of said motor and subsequent rotation of the corresponding said auger occurring when one of said optical sensors detects a decreased level of particulate material in said container.

21. The air seeder of Claim 14, wherein said auger is initiated in response to a sensed lowered torque to effect rotation of said auger as said particulate product drains from said container.

22. A method of conveying particulate material from an air seeder having a container for holding a supply of said particulate material and a metering mechanism for dispensing said particulate material, comprising the steps of:

allowing said particulate material within said container to drain by gravity into said metering mechanism;

sensing a shortage of supply of said particulate material to be dispensed from said metering mechanism as a result of said allowing step; and

rotating an auger housed within a trough in a floor member of said container to deliver any remaining particulate material within said container to said metering mechanism.

23. The method of Claim 22, wherein said sensing step includes the step of sensing a lack of sufficient supply of particulate material within said metering mechanism.

24. The method of Claim 22, wherein said sensing step includes the step of sensing a predetermined level of supply of particulate material within said container with an optical sensor.

25. The method of Claim 22, wherein said sensing step includes the step of sensing a lowered torque requirement to effect rotation of said auger.

26. The method of Claim 22, wherein said allowing step is enhanced by the shape of said floor of said container to drain particulate material both vertically and horizontally into said metering mechanism.

27. The method of Claim 26, wherein said rotating step is accomplished by initiating a motor connected to an end of said auger remote from said metering mechanism.

28. The method of Claim 27, wherein said air seeder is provided with at least two containers for housing different particulate material, said allowing, sensing and rotating steps being accomplished independently within each respective said container.

Fig. 1  
(PRIOR ART)

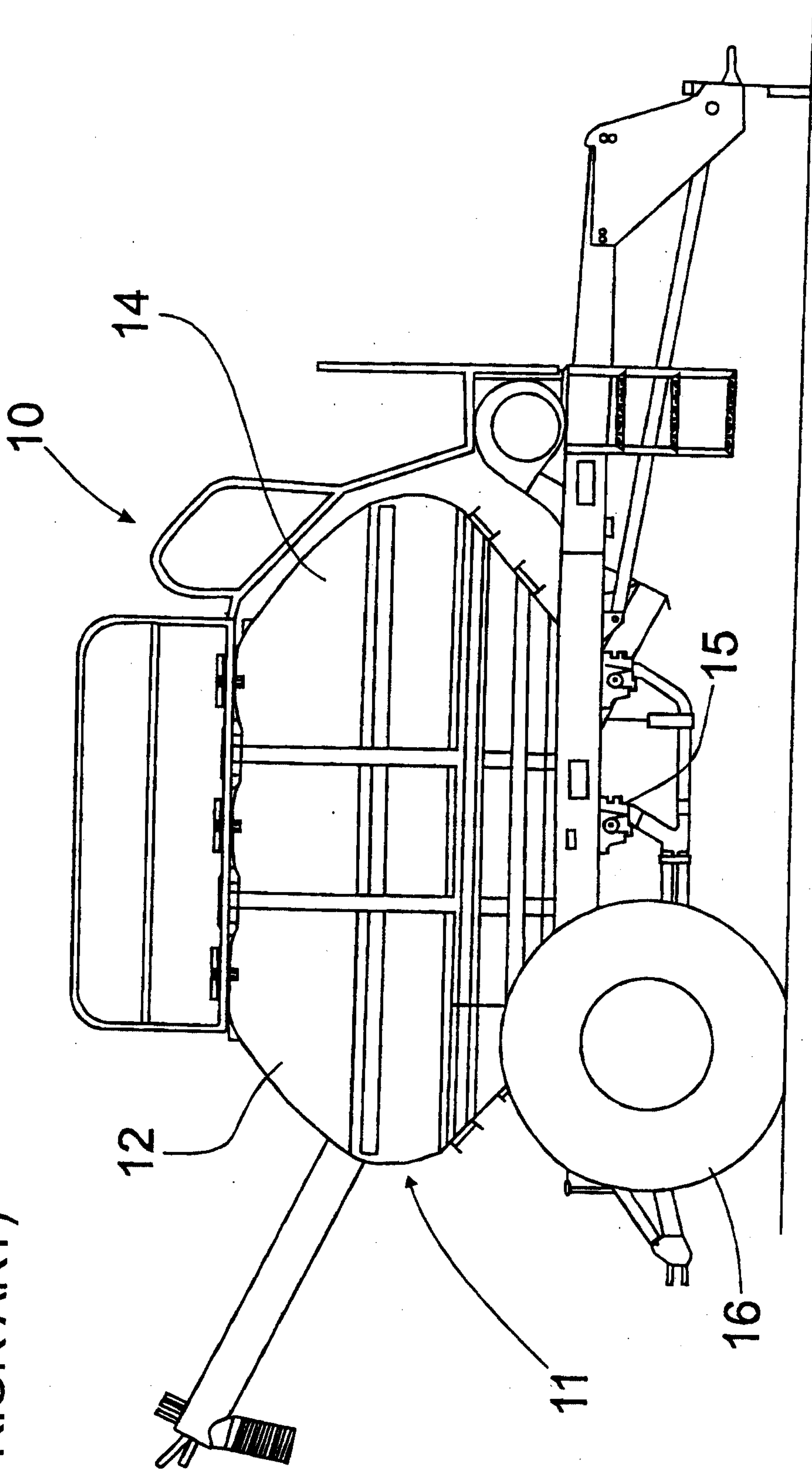

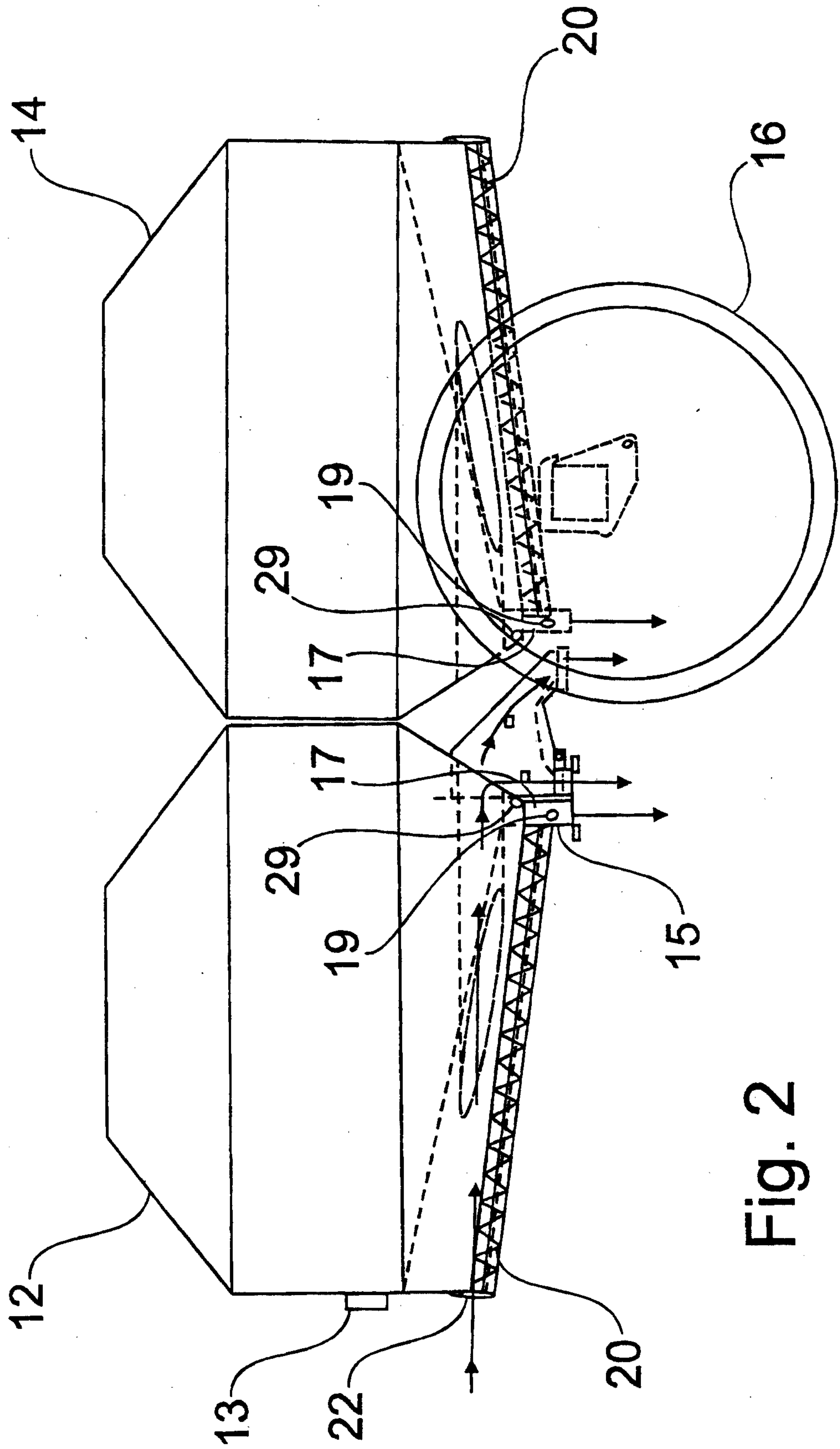

Fig. 2

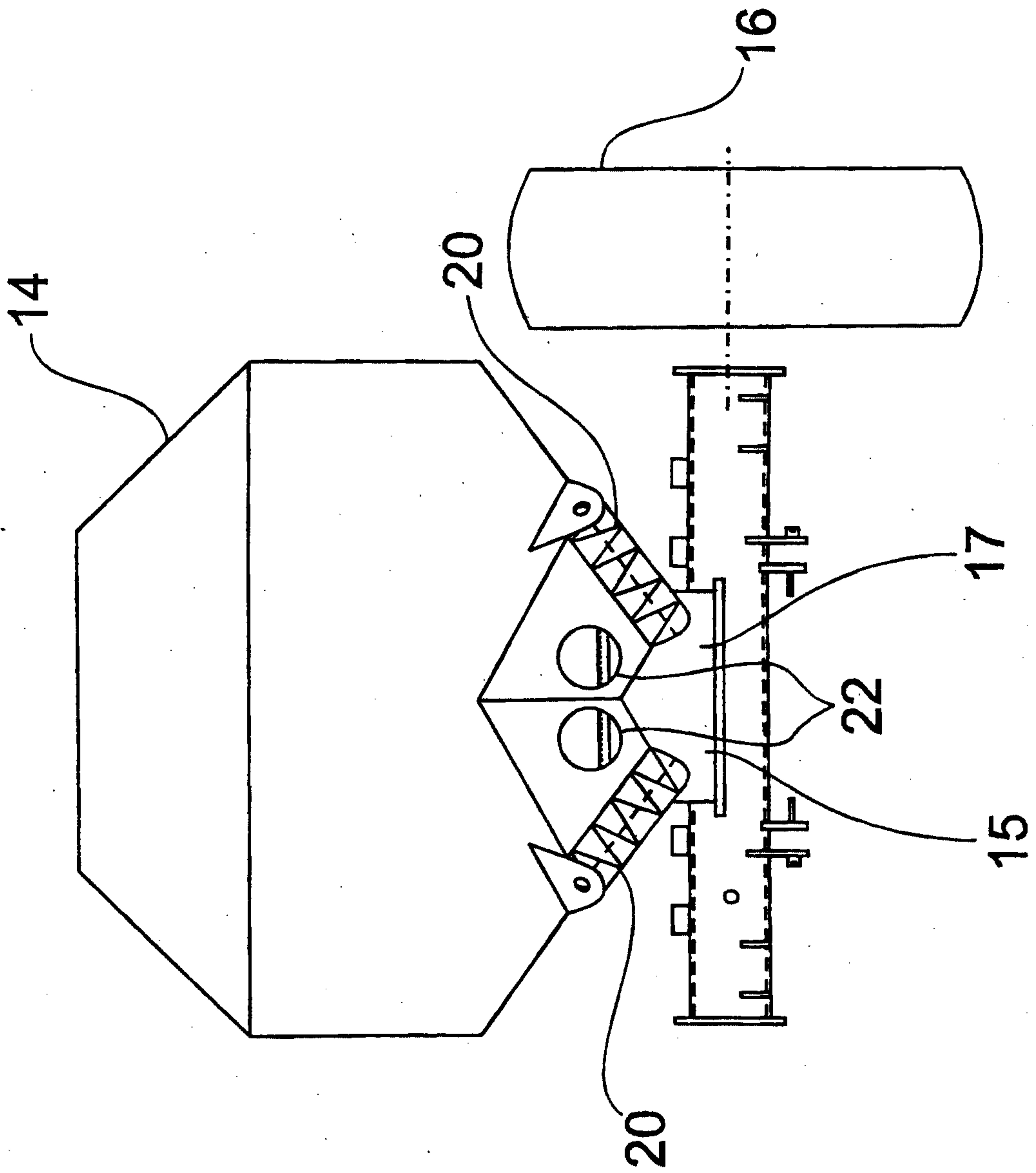

Fig. 3



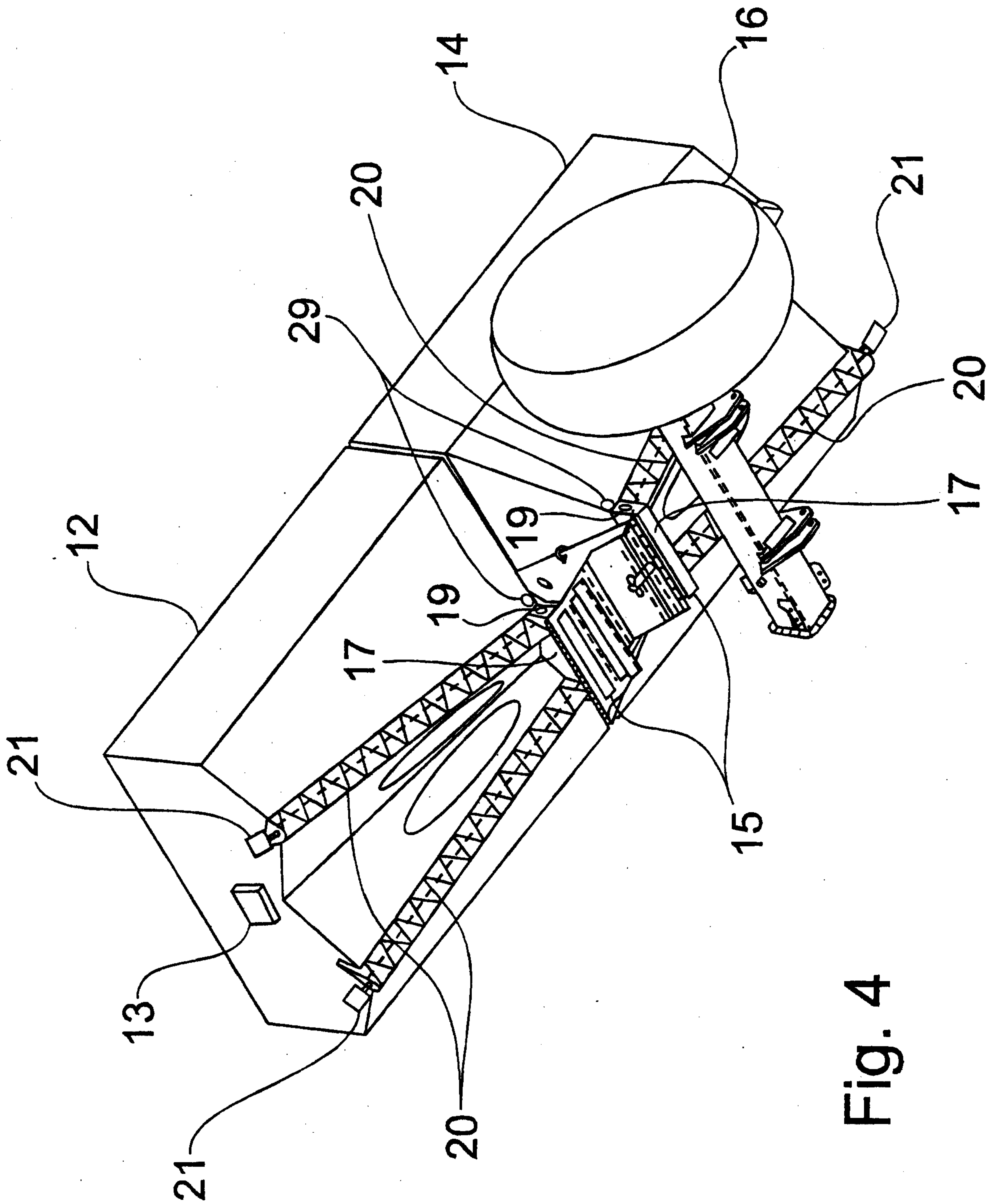
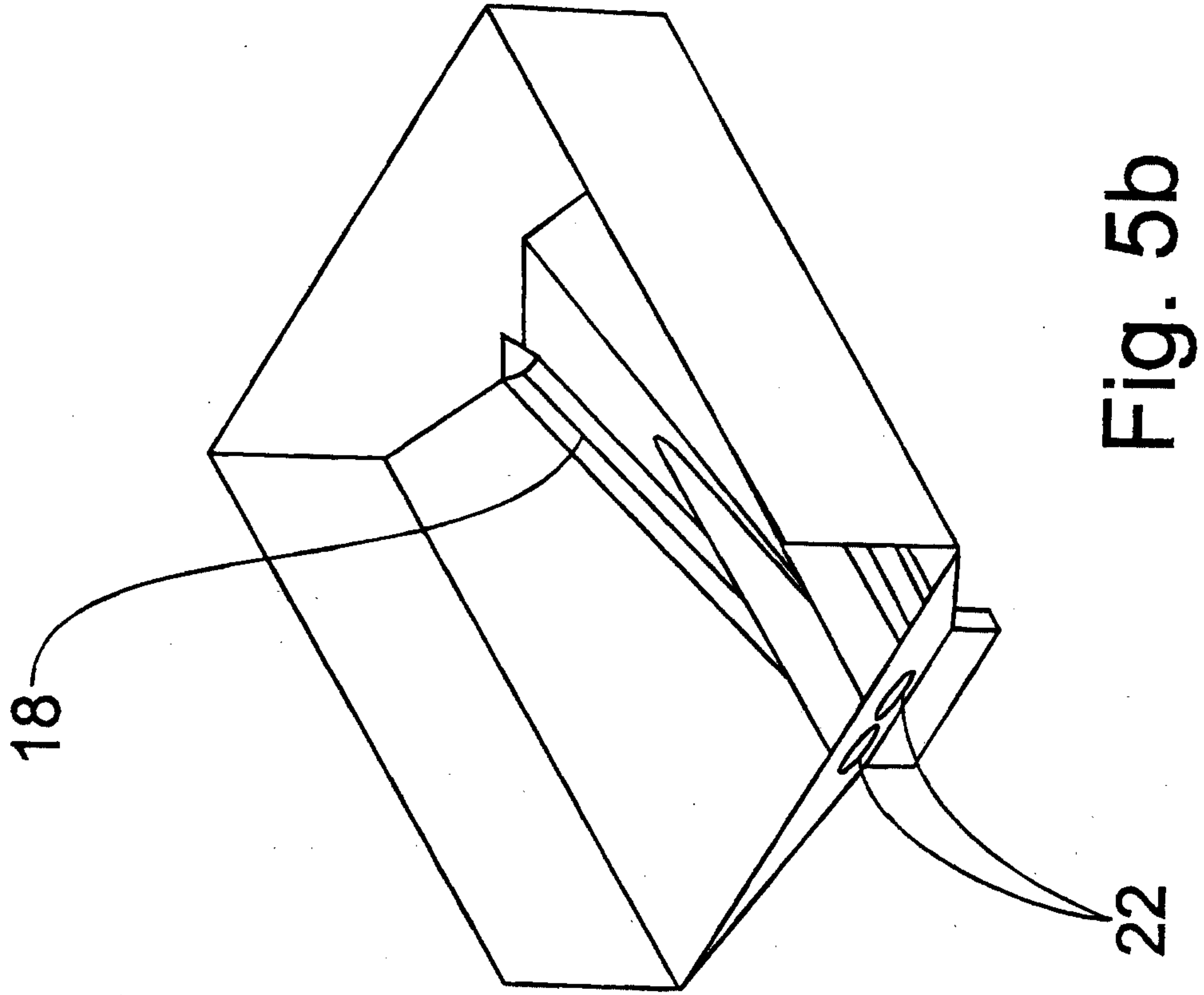
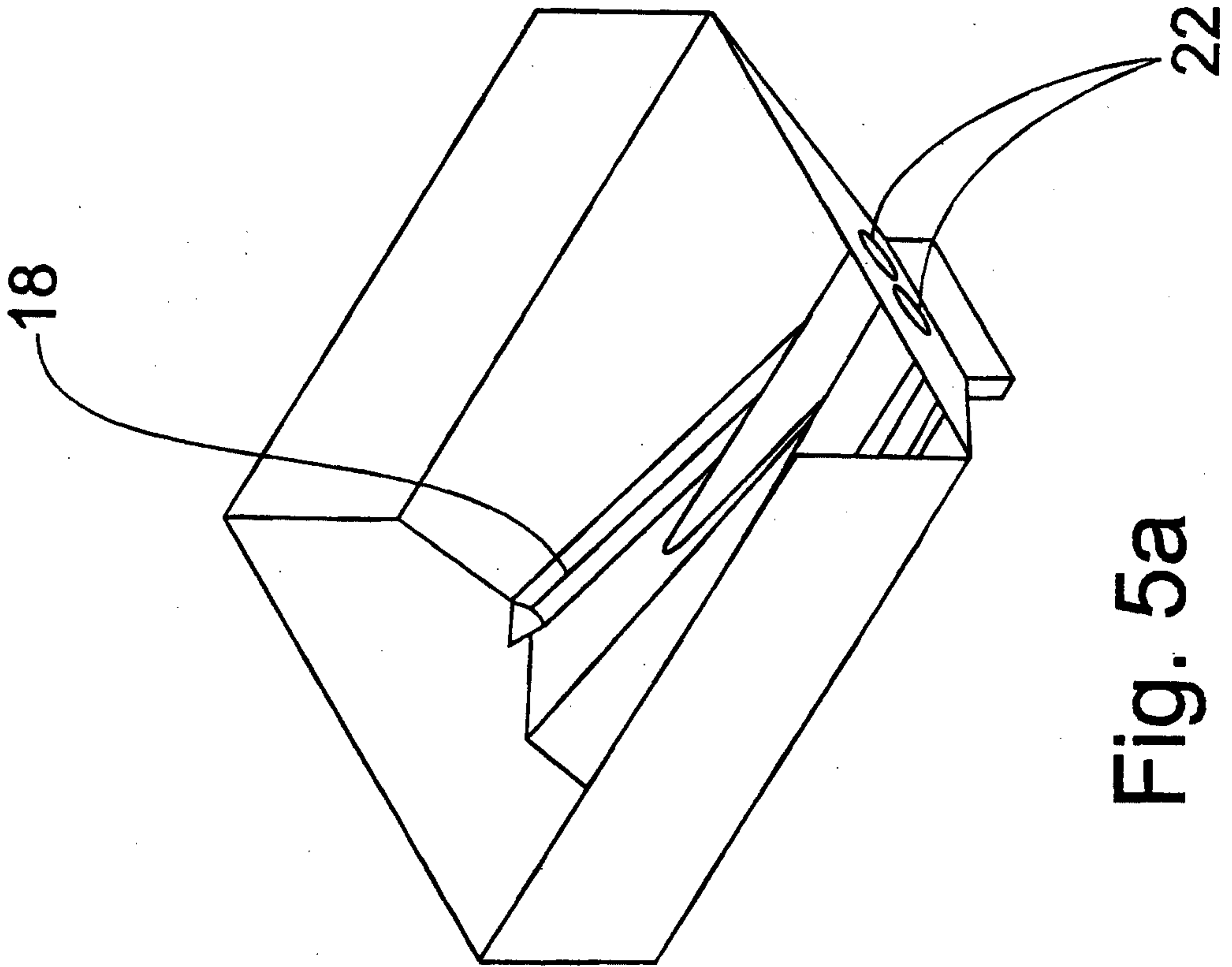
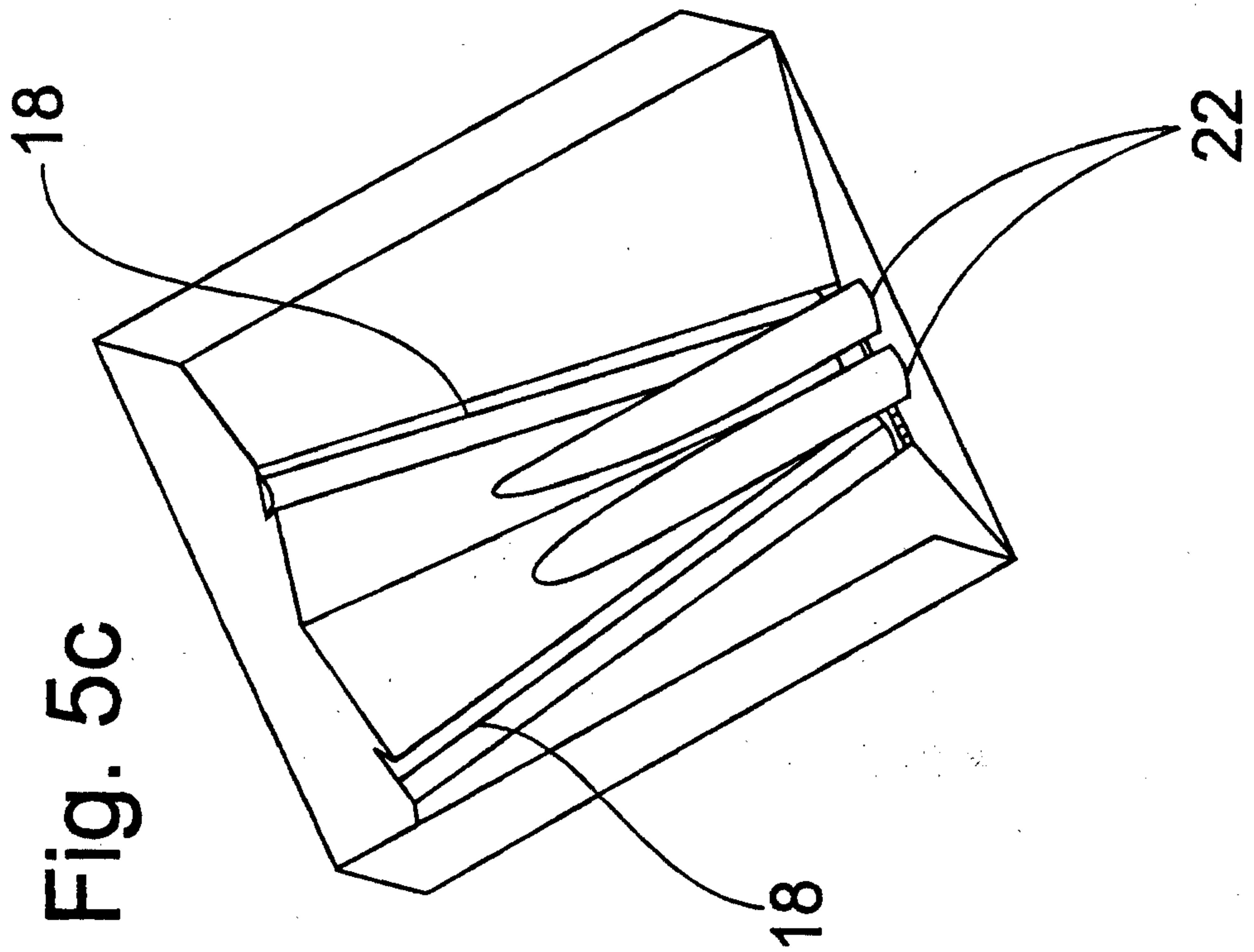
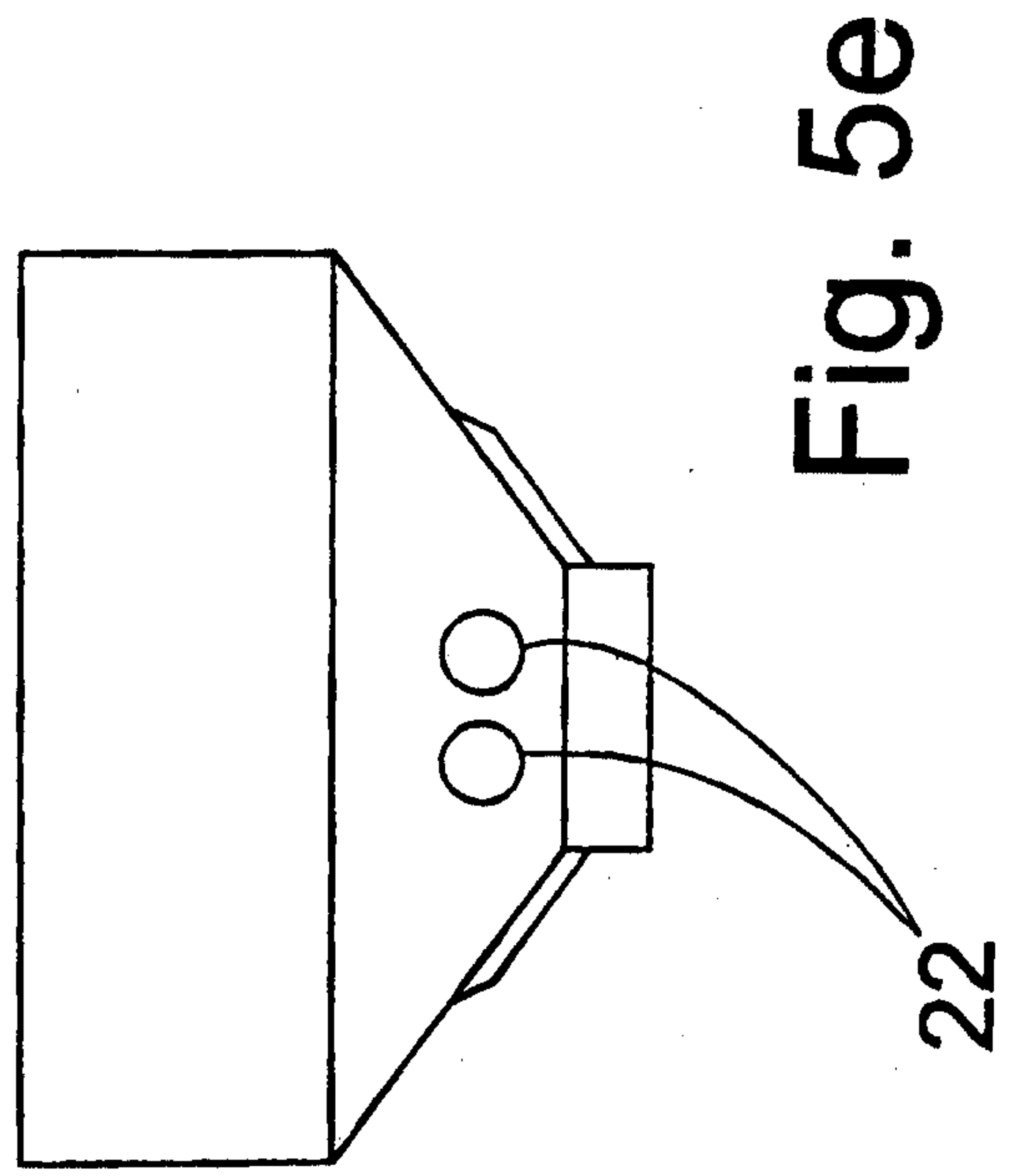
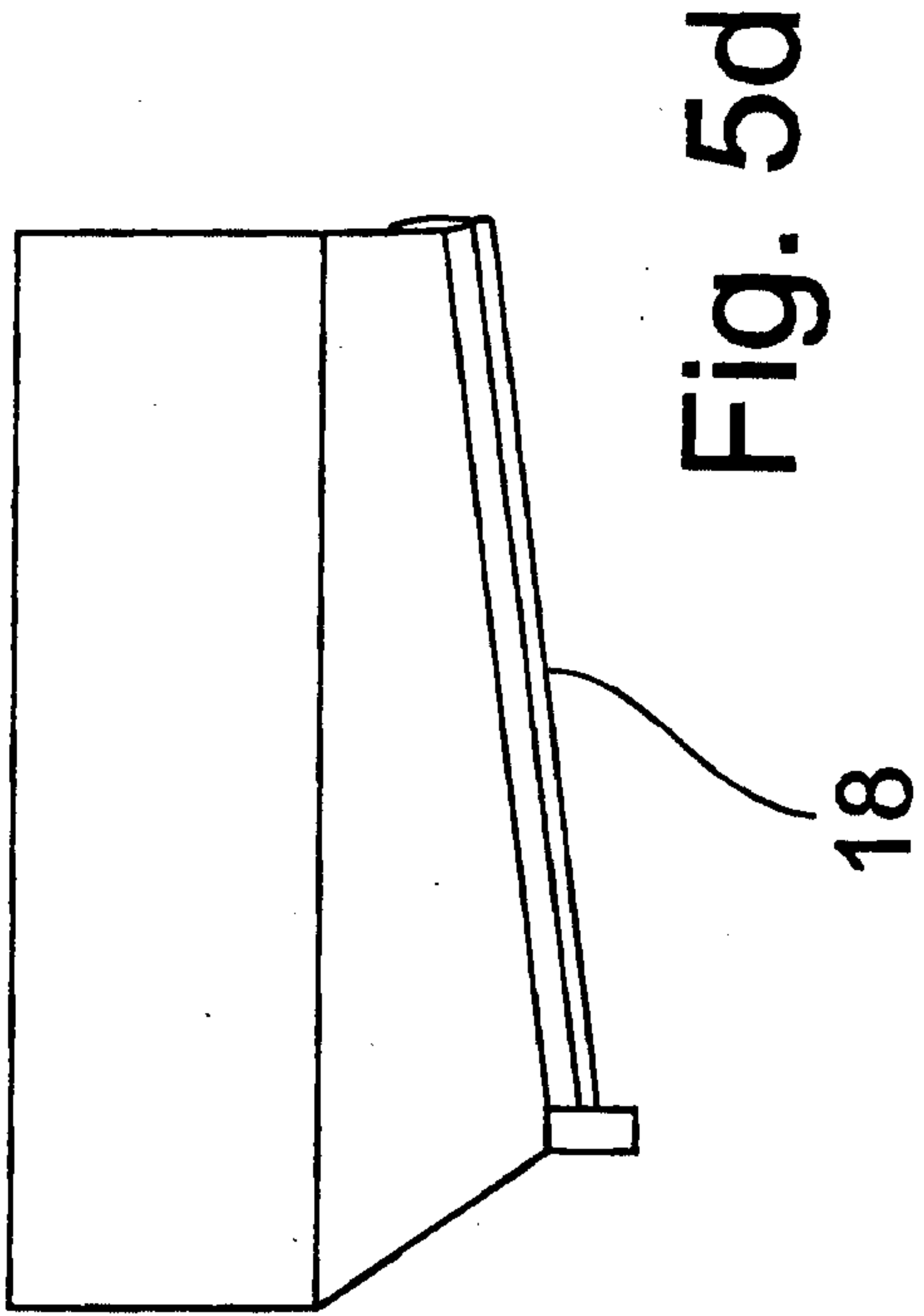

Fig. 4





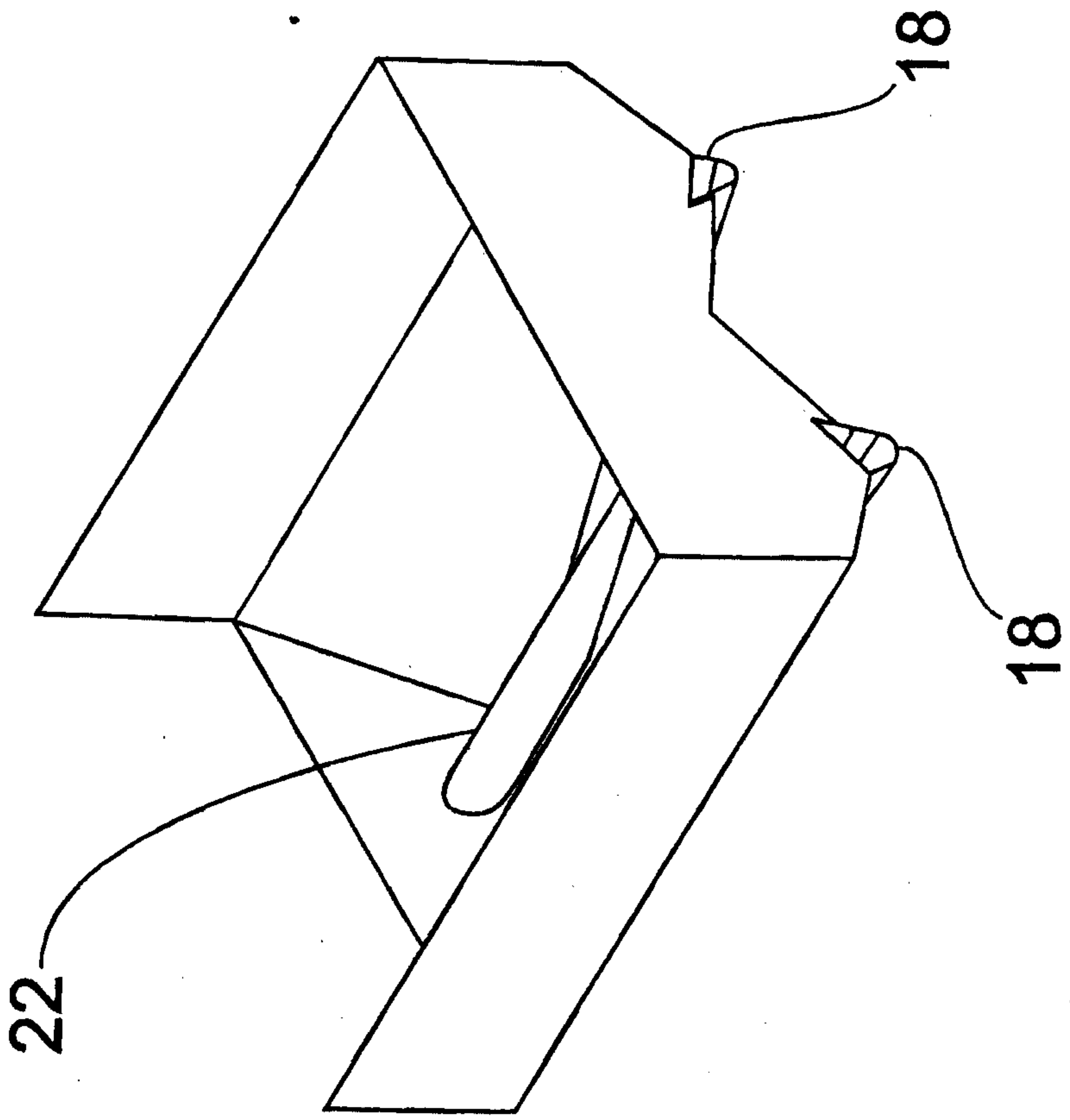

Fig. 59

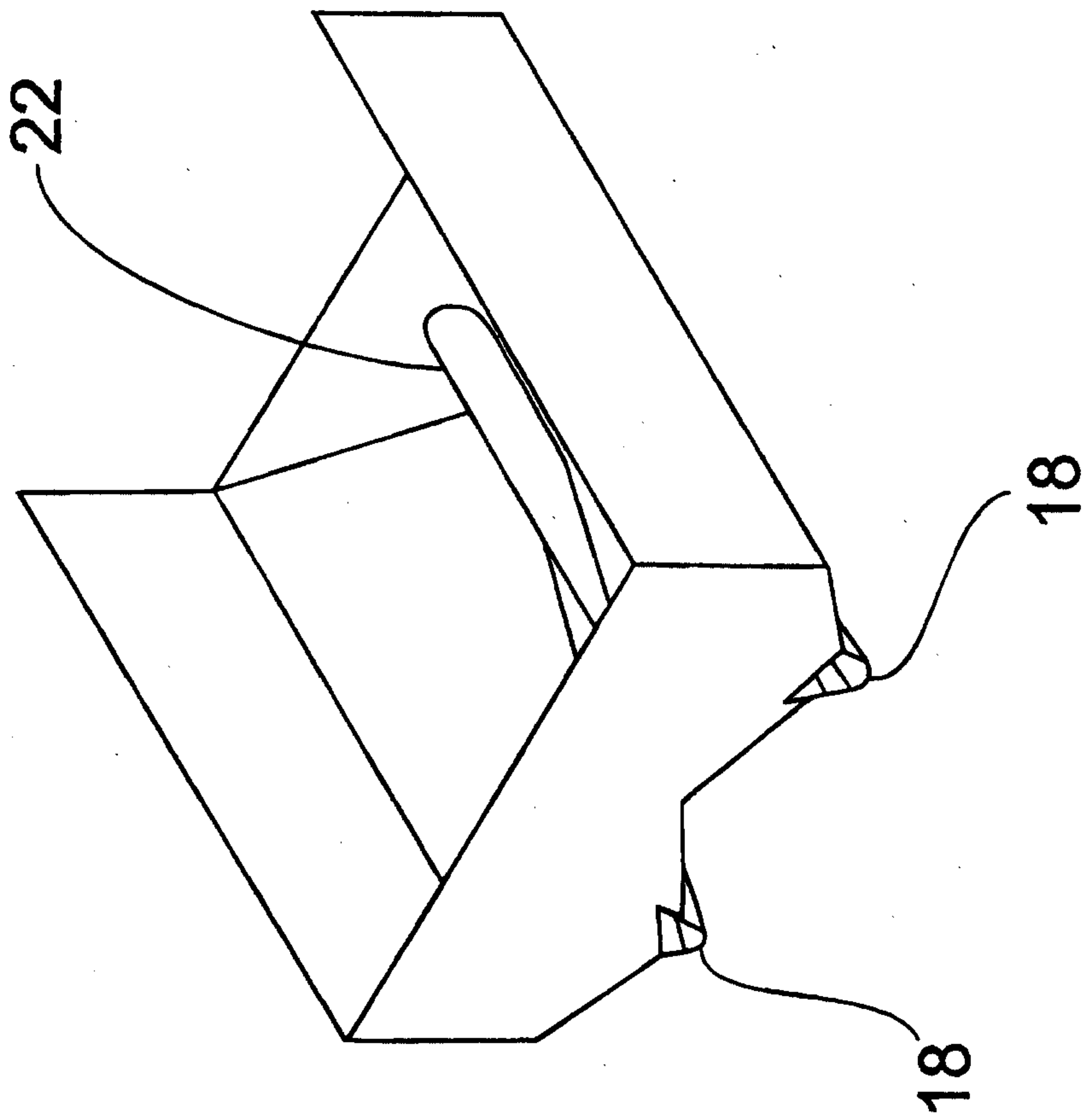

Fig. 5f

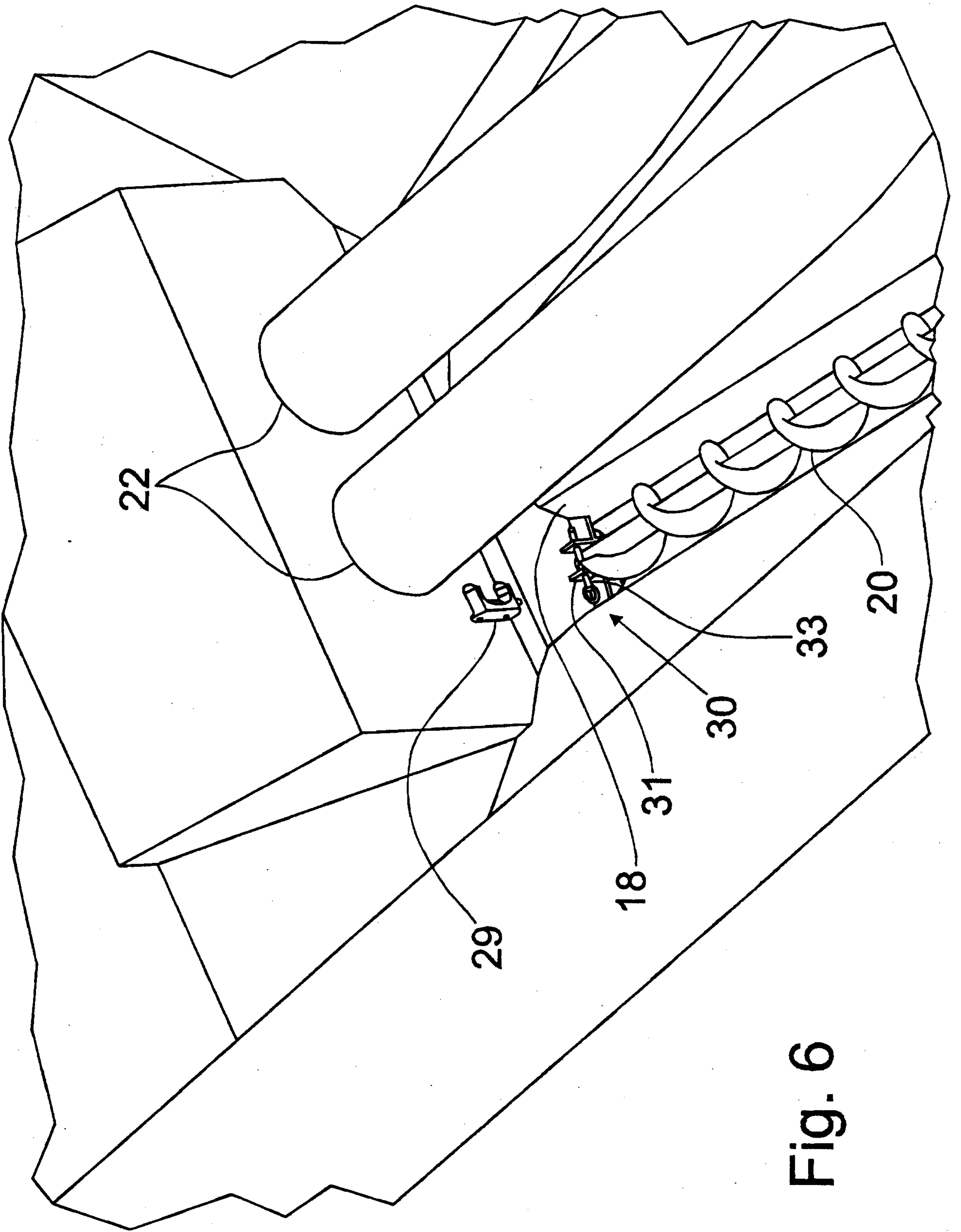

Fig. 6

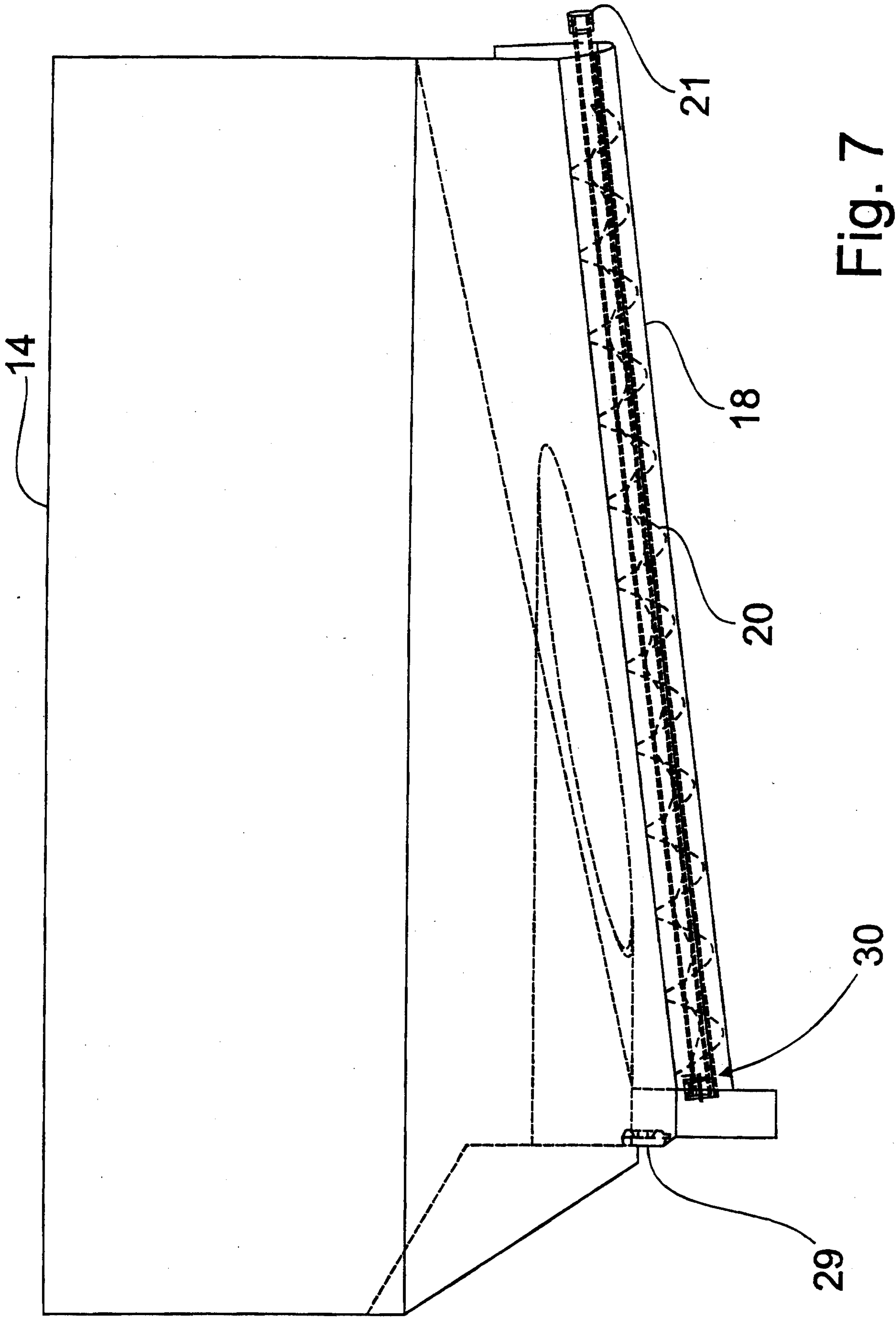

Fig. 7

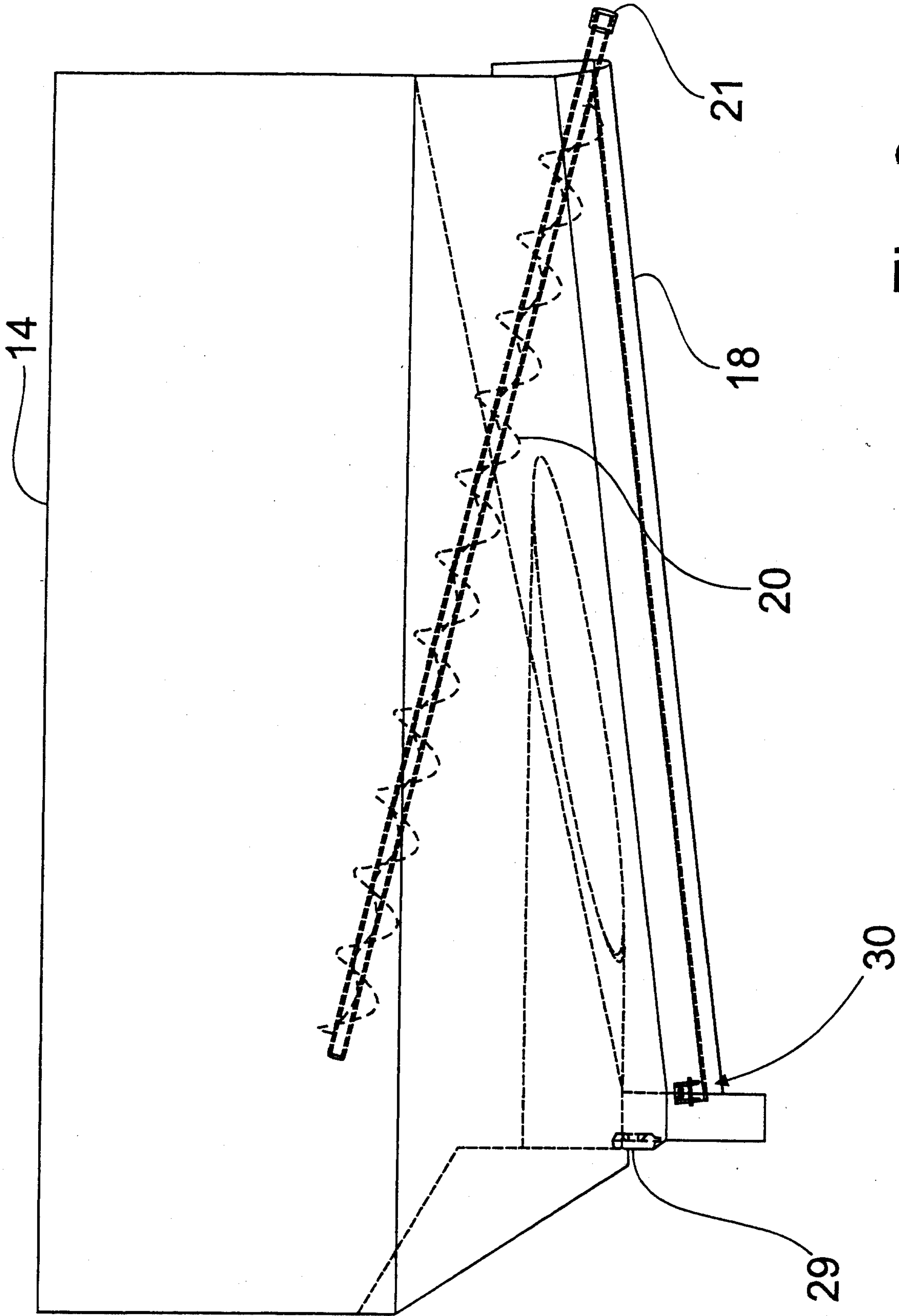

Fig. 8

