

(19)  
(12)

(KR)  
(B1)

(51) 。 Int. Cl.<sup>7</sup>  
G02F 1/1335

(45)  
(11)  
(24)

2004 05 03  
10-0429429  
2004 04 19

(21) 10-2001-0069658  
(22) 2001 11 09

(65)  
(43)

10-2002-0036742  
2002 05 16

(30) JP-P-2000-00343714 2000 11 10 (JP)

(73) 가 가 가 , . 1753

(72)

5-7-1 가 가

5-7-1 가 가

5-7-1 가 가

5-7-1 가 가

5-7-1 가 가

(74)  
:

(54)

1 2 (a) 1 (14) ; (b) 1 (14) 2 (20) ; (c)  
15); (e) 1 (14) (14) 20) (12) ; (d) 1 (14) (16); (f) 1  
(14) (14) (15) (19); (16) (16)  
(compensation layer; 17a, 18) . (19) (16)  
(17a, 18) 1 (14) (19)

1  
 2 1  
 3 1  
 4 3  
 5 3  
 6a 3  
 6b 3  
 7a 7d 3  
 8a 8b  
 9a 9b  
 10a  
 10b  
 14 : 1 15 :  
 16 : 17a : 1  
 17b : 2 18 :  
 19 : 19a :  
 20 : 2

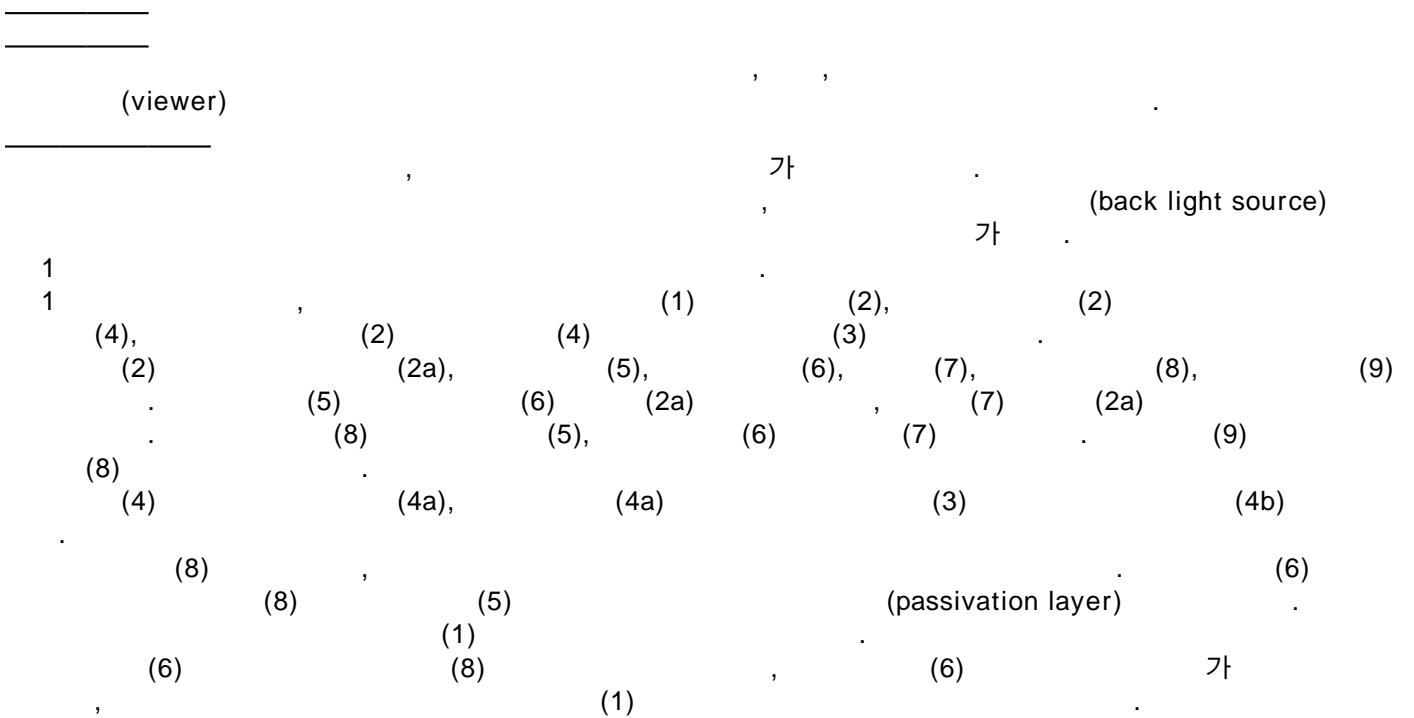

2  
2  
(2) (6) (9) (9) (Lia Lib) (Lra Lrb) (1) (4) (3) (3) (2) (4) (6) (4) (8) (6) (4) (Lrb)

(9) (Lra) 가 , 가 (Lrb) (Lrb)

가

b) 1 1 2 (a) 1 , (c) 1 2 , (d) 1 , (e) 1 , (f) 1 , (g) 1 (compensation layer)

1 1 1 1 2 1 2

1 2 , (a) 1 1 , (b) 1 1 , (c) 1 2 , (d) 1 , (e) 1

3  
3  
(13), 1 (10) (11) (10) (11) (12) (TFT)

(10) (11) 1 (14), (15), (16), (16)

1 (17a) 1 (17a) (17b), 1 (14),

1 (15), 1 (17a) 2 (17b) (18),

(16) (15) (16) 1 (14) (18) (19)

1 (14) (18) (18a) (17b)

(16) (15) (17a) (18) , 2 (17b)

(18) (19) ( ) ,

(19) (13) (19)

(13) 2 (20), 2 (20) (12)

(21) (20) 가 , (12) (11) , (11)

2 (12) (20) (17a) 2 (17b)

4 1 (17a) 2 (17a) , 2 (17b)

4 1 (17a)

1 2 (17a 17b)가 4 , 1 2 (17a 17b)

(18) 1 2 (17a 17b) 가 , (17a 17b)

) 1 (18) (17a)가 (16) (18) 1 2 1 (17a) 2 (17b) (17a 17b) 2 (18) (17b) (18) , 2 (16) 1 (17a) (18) 3 (18) 5 , 1 (17a) (18) 1 (14) (18) (19) (19) (13) (12) 5 (13) (12) (19) (10) (Lia) (13) 가 (12) (11) 5 (19) (12) (Lra) (13) (19) (Lib) (13) 가 (12) (11) (16) (12) (Lrb) (13) (12) (Lia) n×Da (12) Da n (12) (19) (13) Db 2 n×Db n (12) ) (13) (19) , Da Db (Lia) (Lib) 2 (Lra) (Lib) (n×Da) 2 (n×Db) (16) (Lrb) 가 (6a) (10) (16) (19) (19) (16) (19) (19) (16) (18) (19) (19) (16) (19) (19) (19) (19) (19) (19) (19) (16) , 1 (19) (16) (19) (16) (16) (10) , 가 (10) (6b) (10) (16) (19) (18) 6b (19) (19) (16) (19) (19) (16) (19) , 1 (16) (19) (19) (19) (16) (19) (19) (19) (10) , 7a 7d (15) (16) 1 (14) , 7a (17a)가 (16) 2 (17b)가 (7b) , 1 (17a 17b) (15) (16) 1 (14) (17a 17b) (organic resin) , (18) 1 2 (17a 17b) , (18a) (18) (18a) 가 (15) (18a) (18) (19) (raised portio ns) , (19) (18a) (19) (19) (19) (19) (19) (19) (19) (19) 7d 8a 8b (10) (19) (19) 8a (19a) (22) (19a) , 8b (19a) (19) (19) (22) (16) (19a) (19) (16) (19) (16) (19)

9a 9b (10) (19)  
 9a (19a) (22) (22) (22)  
 16) 가 (16) (22a) 가 (19) (22)  
 16) (19a) 9b (19) (19) (22)  
 (22) 9b (19) (16)  
 1 (17a) (18) (19)  
 10a 10b 1 2 (17a 17b)  
 10a 4μm 1 2 (17a 17b) 7μm  
 2.2μm 가 10b 10μm 1 2 ( )  
 17a 17b) 13μm 2.8μm 가 (17a 17b) 1  
 (17a) 2 (17a 17b)  
 1 2 (17a 17b)가 1 (17a) 가  
 2 (17b)  
 1 (17a) 2 (17b) 가  
 (16) 1 (19) (16) (10) (18)  
 (17b) 1 (17a)가 2  
 2) 1 (10) (16) (18) (19) (1)  
 (16) (16) (16) (18) (19)  
 (10) 1 (17a) 1 (17a) (18)  
 (19) (18) (19) (16)  
 10) (Lrb) 가 ( )  
 (10) 가  
 가 (10) (15)가  
 가 (15) 1 (17a) (18) Da Db( 5 )  
 (16) 1 (17a) (18) (17a) (18)  
 1 2 2  
 가

(57)

- 1.
- (a) 1 ;
- (b) 1 2 ;
- (c) 1 2 ;
- (d) 1 ;
- (e) 1 ;

(f) 1 , (19);  
(g) ,

(inclining portios) 가 ,

1 2. ,

가 , 1 ,

1 3. ,

1 ,

3 4. ,

가

4 5. ,

가

4 6. ,

1 7. 6 ,

1 8. 6 ,

9.

3 10. ,

1 2 ,

10 11. ,

11 12. ,

13.

1 ; 1 2 ; 1 2 ;

(a) 1 ; ;

(b) 1 2 1 ; 2 ;

(c) 1 2 ; ;

(d) ; ;

(e) ; ,

가 , (raised portions)  
(inclining portions)  
,

13 14.  
(e) :  
(e1) ;  
(e2) ;  
(e3)

13 15.  
1 2 ,

13 16. 15  
,

13 17. 15  
,

13 18. 15  
1 , 2

18 19.  
1 ,

1 20.  
,

1 21.  
,

증래기술

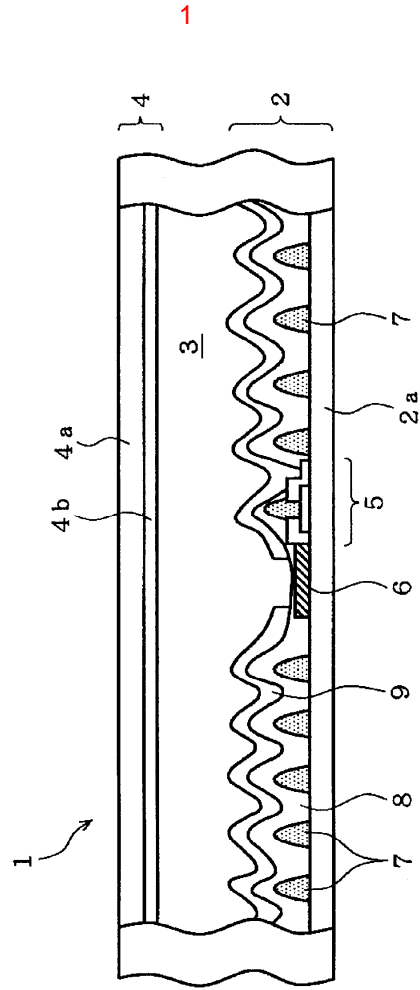



종래기술

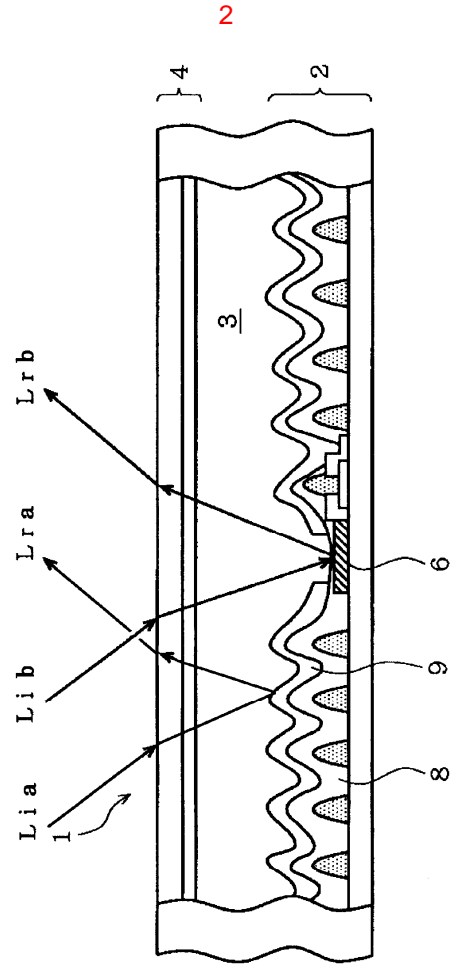

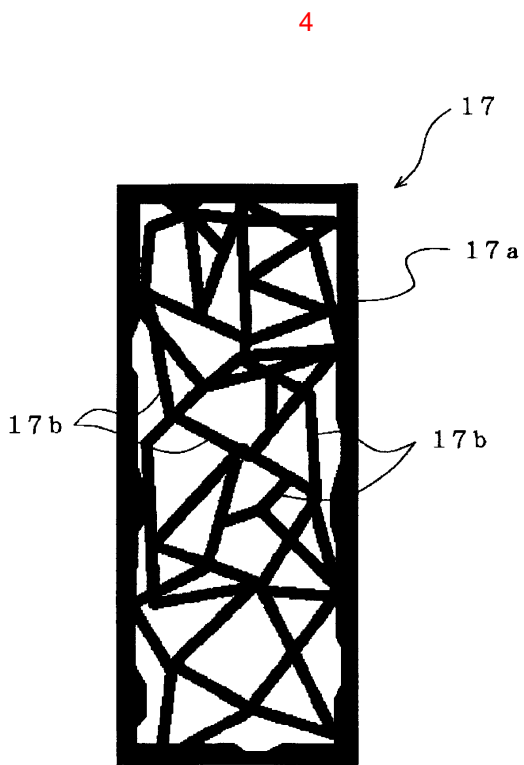
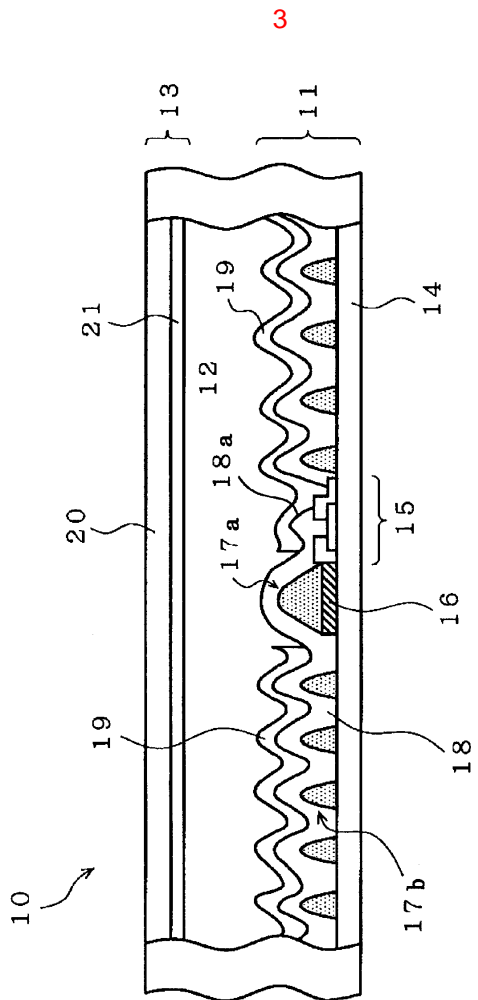

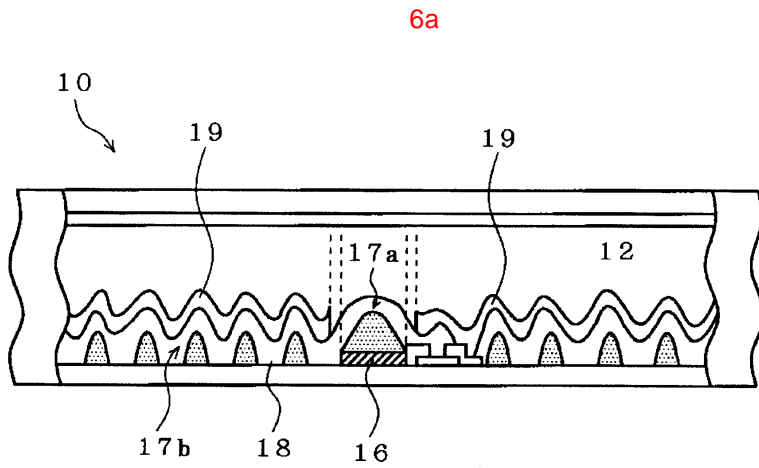
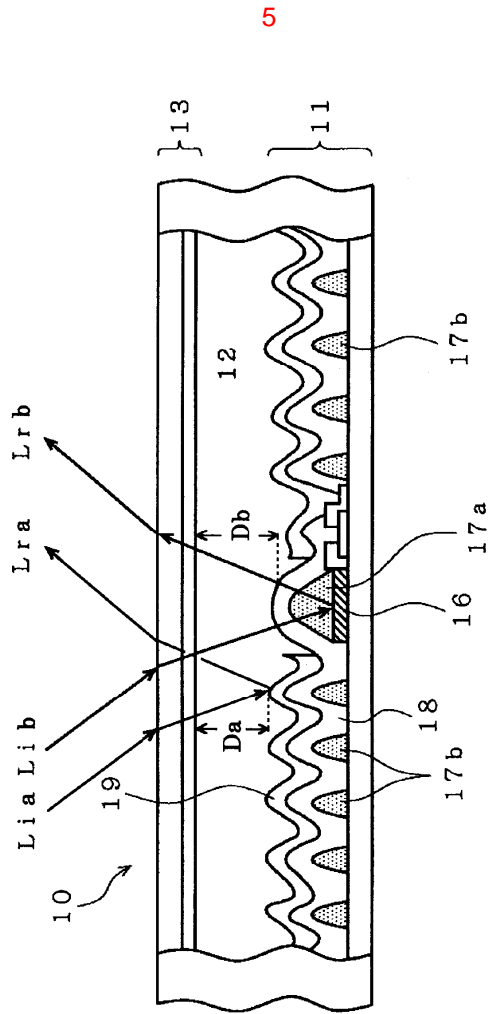

6b

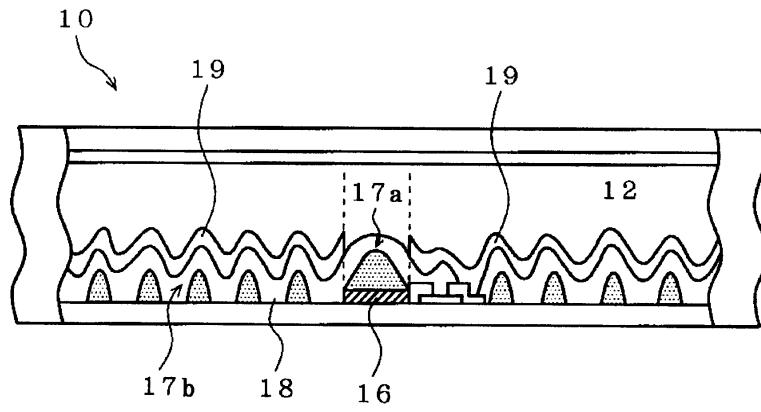

7a

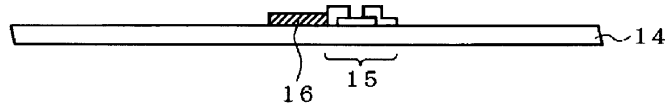

7b

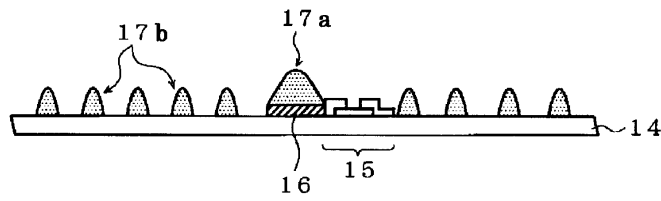

7c

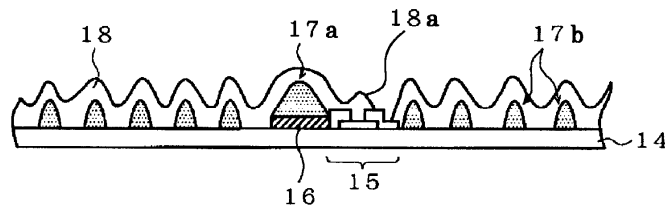

7d

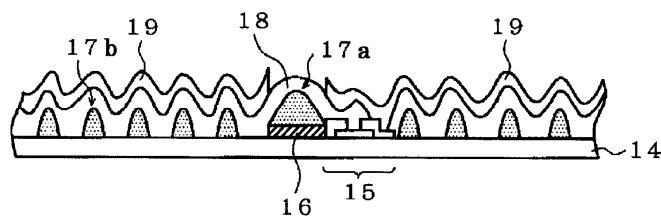

8a

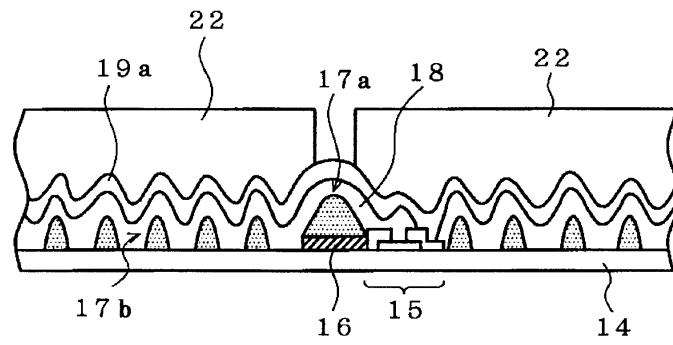

8b

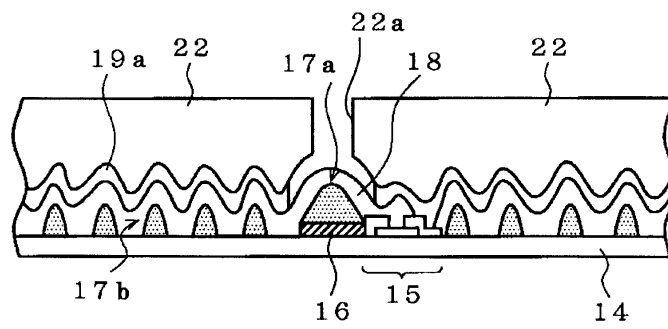

9a

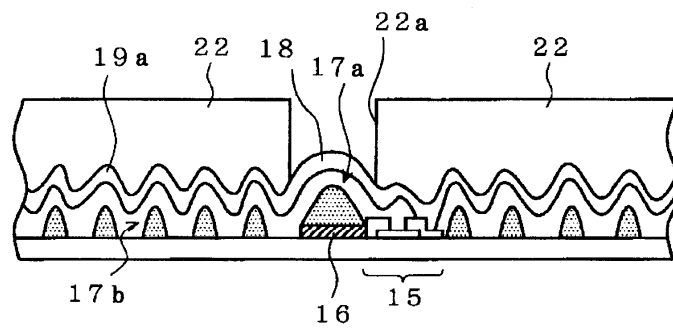

9b

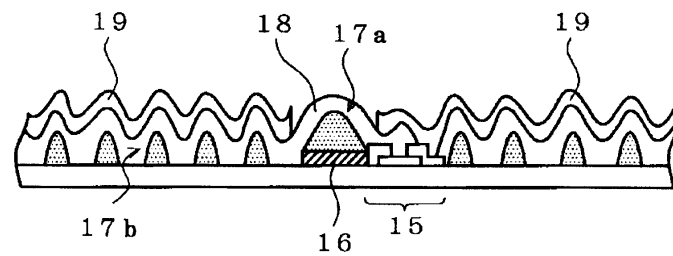

10a

마스크 패턴 폭  $4\mu\text{m}$

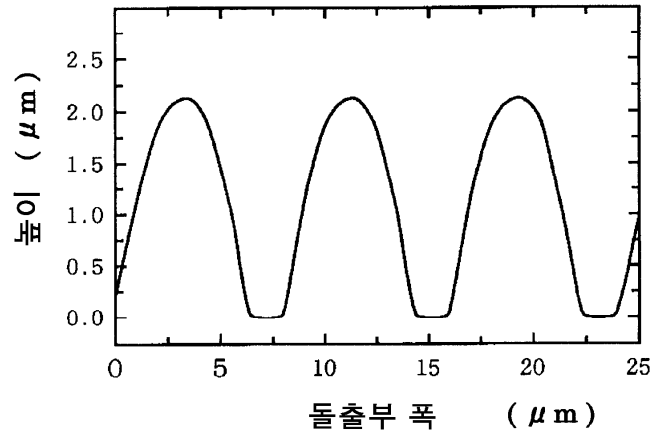

10b

마스크 패턴 폭  $10\mu\text{m}$

