



US00D572866S

(12) **United States Design Patent**
Bloedorn

(10) **Patent No.:** **US D572,866 S**

(45) **Date of Patent:** **** Jul. 8, 2008**

(54) **BIRD FEEDER**

(57) **CLAIM**

(75) Inventor: **Daniel A. Bloedorn**, Chilton, WI (US)

I claim the ornamental design for a bird feeder, as shown and described.

(73) Assignee: **Backyard Nature Products, Inc.**,
Chilton, WI (US)

(**) Term: **14 Years**

(21) Appl. No.: **29/251,770**

(22) Filed: **Jan. 12, 2006**

(51) **LOC (8) Cl.** **30-03**

(52) **U.S. Cl.** **D30/127; D30/128**

(58) **Field of Classification Search** D30/121,
D30/124-128, 133; 119/51.01, 52.2-52.4,
119/57.8, 57.9, 248; 248/219.1, 222.11,
248/224.7, 229.1, 230.1, 689

See application file for complete search history.

(56) **References Cited**

U.S. PATENT DOCUMENTS

| | | | | |
|-----------|-----|---------|----------------|---------|
| 3,568,641 | A | 3/1971 | Kilham | |
| D231,369 | S | 4/1974 | Kilham | |
| D245,715 | S | 9/1977 | Eldridge, Jr. | |
| D252,591 | S * | 8/1979 | Hyde, Jr. | D30/127 |
| D262,917 | S | 2/1982 | Kilham | |
| 4,318,364 | A | 3/1982 | Bescherer | |
| 4,355,597 | A | 10/1982 | Blasbalg | |
| 4,356,793 | A | 11/1982 | Blasbalg | |
| 4,434,745 | A | 3/1984 | Perkins et al. | |
| D278,559 | S * | 4/1985 | Latham et al. | D30/127 |
| D282,019 | S | 12/1985 | Kilham | |
| 4,829,934 | A | 5/1989 | Blasbalg | |
| 4,996,947 | A | 3/1991 | Petrides | |

(Continued)

Primary Examiner—Melanie Tung

Assistant Examiner—Susan Moon Lee

(74) *Attorney, Agent, or Firm*—Whyte Hirschboeck Dudek
SC

DESCRIPTION

FIG. 1 is a perspective view of a first embodiment of a bird feeder according to the present design;

FIG. 2 is a front elevation view thereof, the rear view being a mirror image, except for the clip shown on the base thereof;

FIG. 3 is a side elevation view thereof, the opposite side being a mirror image, except for the clip shown on the base thereof;

FIG. 4 is a perspective view of a second embodiment of the bird feeder of FIG. 1;

FIG. 5 is a front elevation view thereof, the rear view being a mirror image, except for the clip shown on the base thereof;

FIG. 6 is a side elevation view thereof, the opposite side being a mirror image, except for the clip shown on the base thereof;

FIG. 7 is a perspective view of a third embodiment of the bird feeder of FIG. 1;

FIG. 8 is a front elevation view thereof, the opposite side being a mirror image, except for the clip shown on the base thereof;

FIG. 9 is a side elevation view thereof, the opposite side being a mirror image, except for the clip shown on the base thereof;

FIG. 10 is a top view of the bird feeder embodiment shown in FIG. 1;

FIG. 11 is a bottom view of the bird feeder embodiment shown in FIG. 1;

FIG. 12 is a top view of the bird feeder for both the second and third embodiments shown in FIGS. 4 and 7; and,

FIG. 13 is a bottom view of the bird feeder for both the second and third embodiments shown in FIGS. 4 and 7.

The broken lines shown in the figures are for illustrative purposes only and form no part of the claimed design.

1 Claim, 8 Drawing Sheets

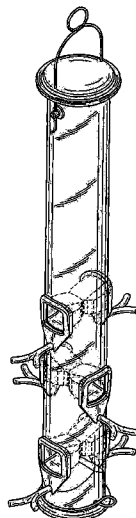

US D572,866 S

Page 2

| U.S. PATENT DOCUMENTS | | | | | |
|-----------------------|---------|------------------------|--|----------------|--------------------------------|
| D320,097 S | 9/1991 | Vajtay | | 5,678,507 A | 10/1997 Kassner |
| 5,062,388 A | 11/1991 | Kilham | | 5,701,842 A | 12/1997 Whittles |
| 5,105,765 A | 4/1992 | Loken | | 5,826,540 A | 10/1998 Bridges |
| 5,123,380 A | 6/1992 | Edwards | | 6,024,049 A | 2/2000 Price |
| 5,215,039 A | 6/1993 | Bescherer | | 6,213,054 B1 * | 4/2001 Marshall 119/57.8 |
| 5,285,747 A * | 2/1994 | Caldine 119/57.9 | | 6,253,707 B1 | 7/2001 Cote |
| D349,982 S | 8/1994 | Hardison | | 6,276,298 B1 | 8/2001 Welsh |
| D359,821 S | 6/1995 | Liethen | | 6,332,427 B1 | 12/2001 Coulson |
| 5,452,682 A | 9/1995 | Bescherer et al. | | 6,378,458 B1 * | 4/2002 Boyd 119/52.3 |
| D367,134 S | 2/1996 | Bescherer | | 6,453,843 B2 | 9/2002 Bescherer |
| 5,642,689 A | 7/1997 | Harvey | | 6,543,383 B1 | 4/2003 Cote |
| 5,671,696 A | 9/1997 | Liethen | | 6,564,745 B1 | 5/2003 Bloedorn |
| D385,067 S | 10/1997 | Whittles | | D477,117 S | 7/2003 Stokes et al. |
| | | | | 6,584,933 B1 * | 7/2003 Stone 119/57.9 |

* cited by examiner

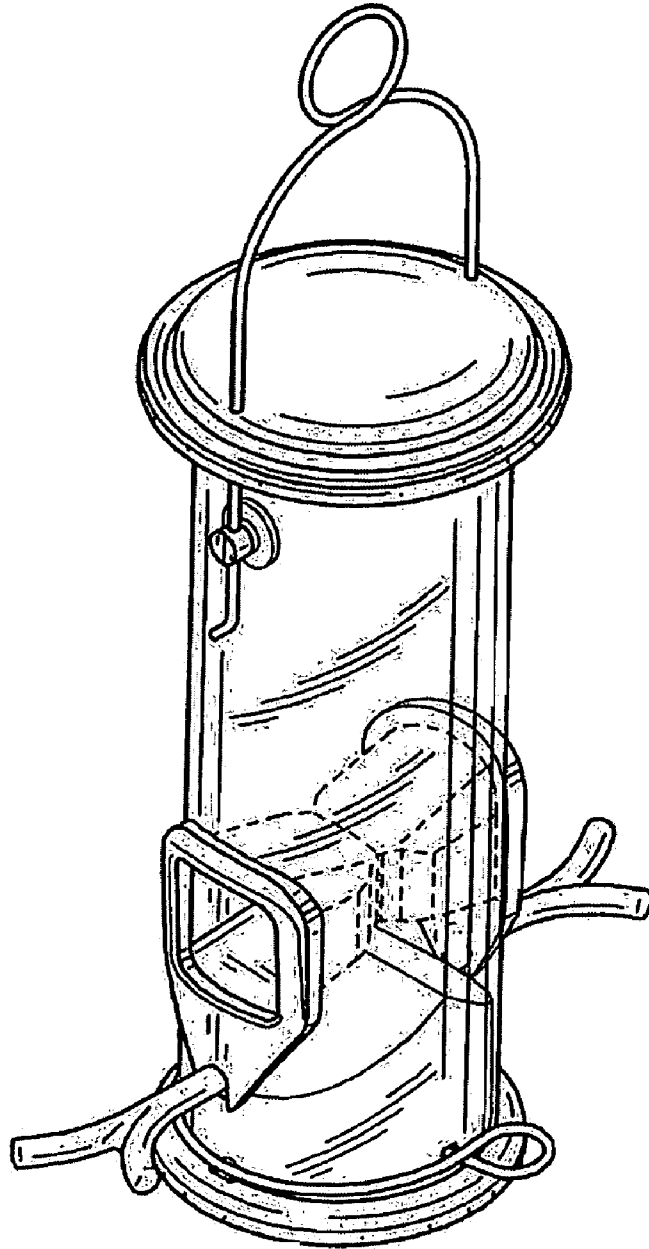

FIG. 1

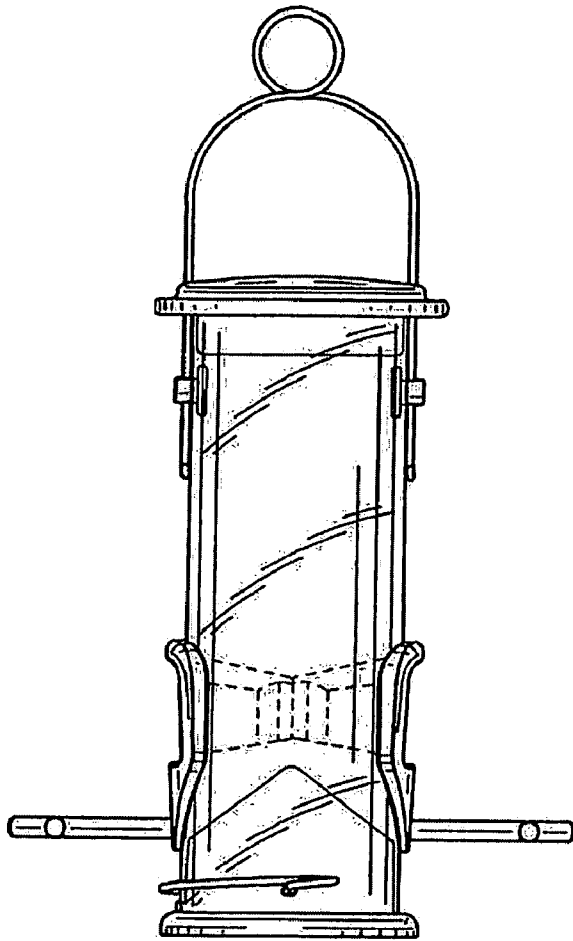

FIG. 2

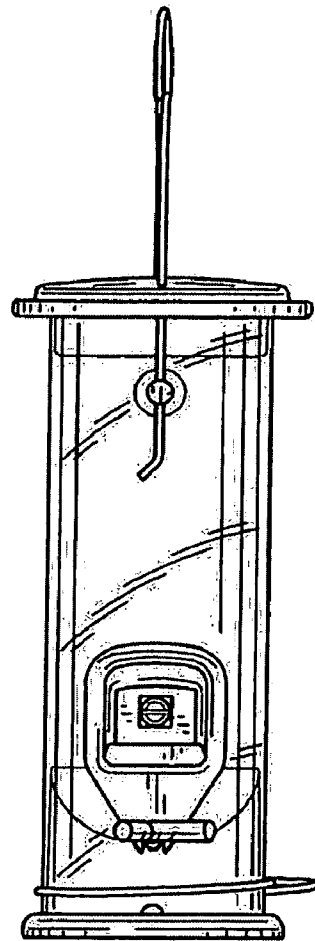

FIG. 3

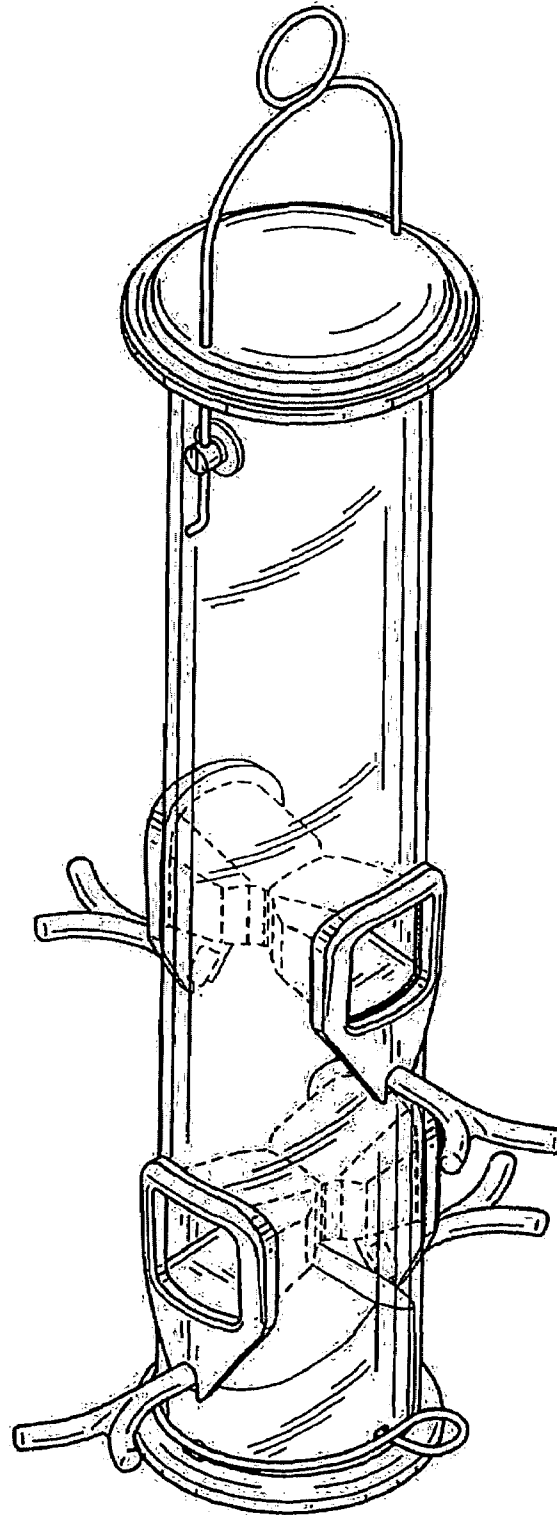

FIG. 4

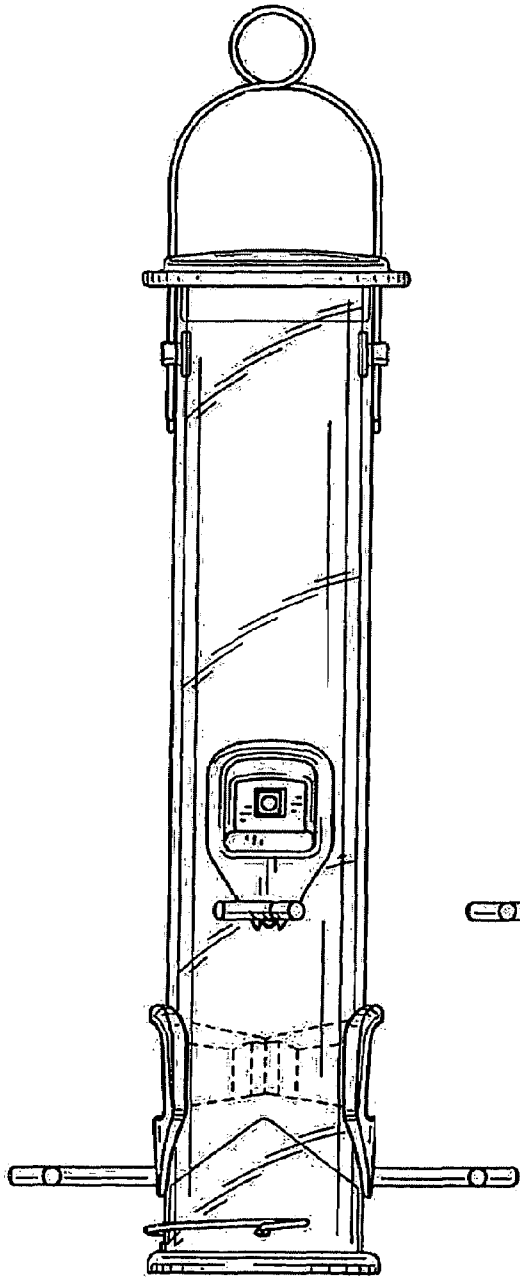

FIG. 5

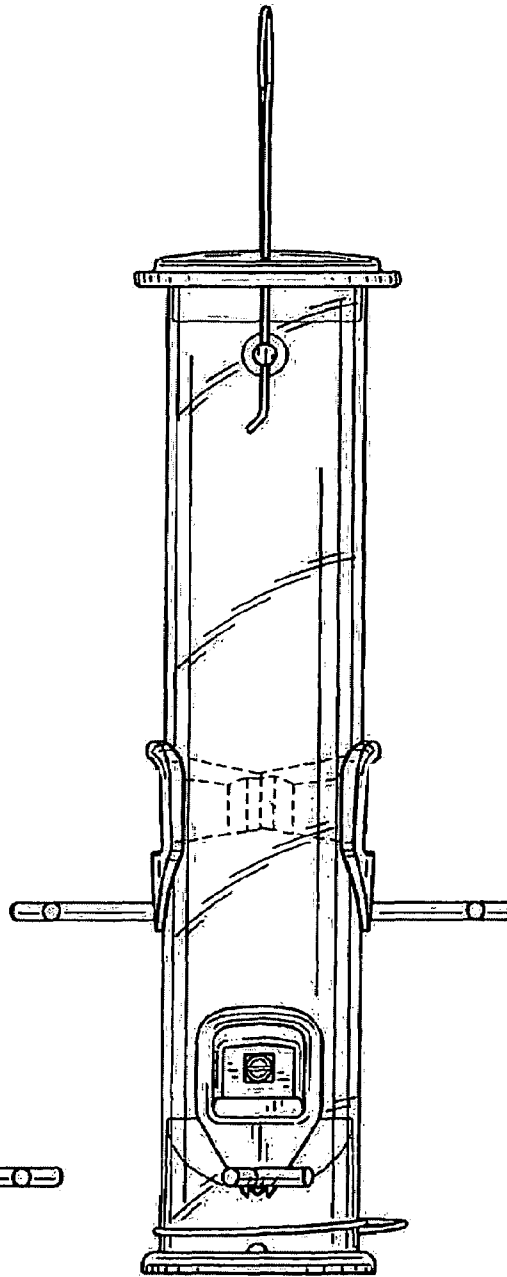

FIG. 6

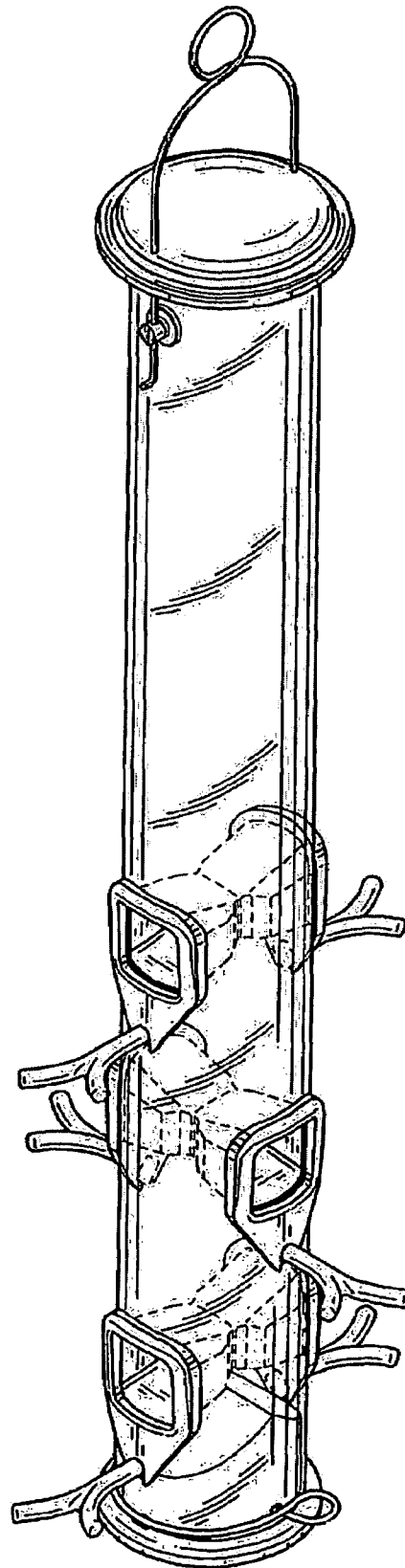

FIG. 7

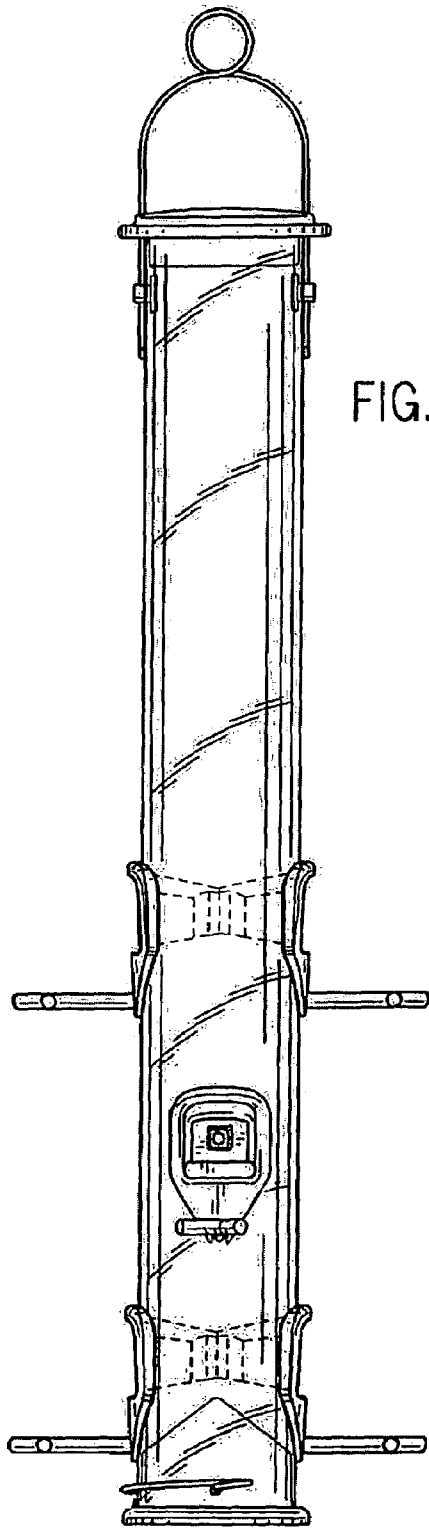

FIG. 8

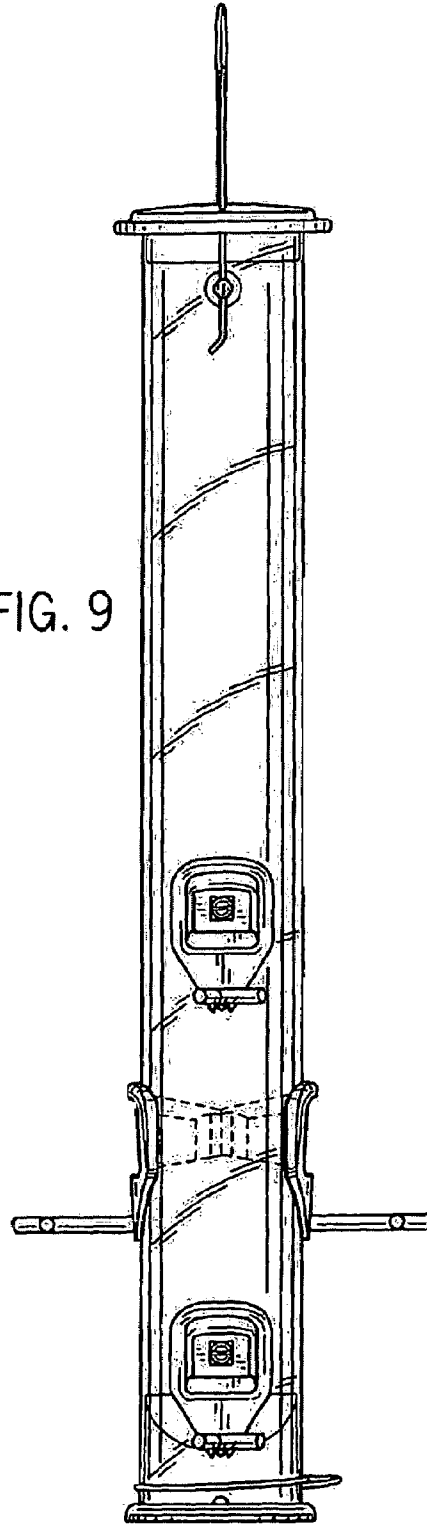

FIG. 9

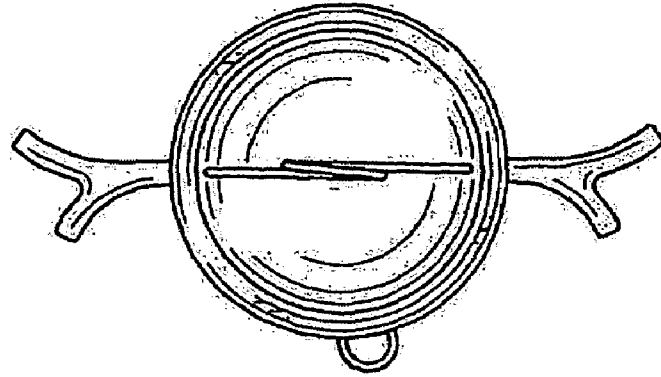

FIG. 10

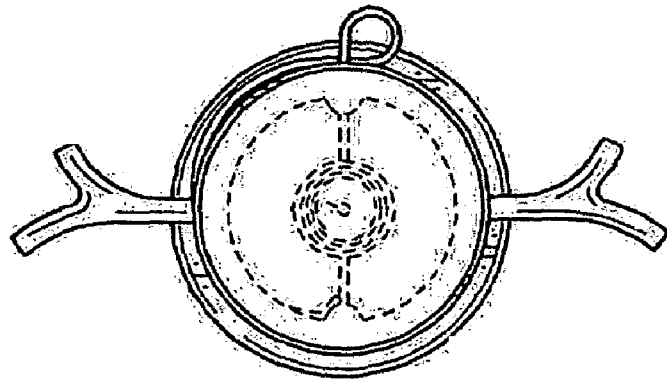

FIG. 11

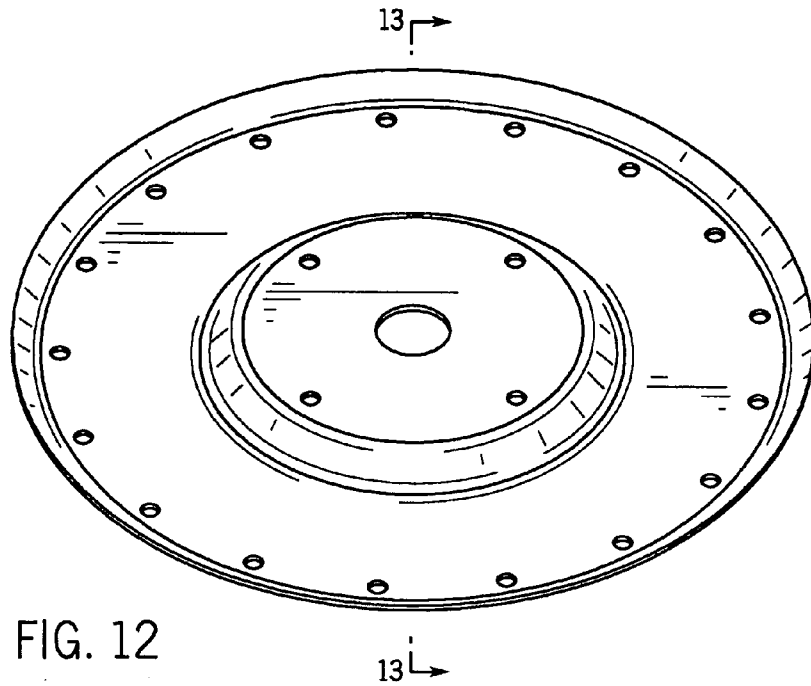

FIG. 12

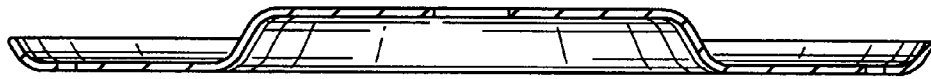

FIG. 13