

(No Model.)

2 Sheets—Sheet 1.

J. W. OSBORNE.

ELECTRICAL APPARATUS FOR AND METHOD OF CONTROLLING PAPER, &c.

No. 287,957.

Patented Nov. 6, 1883.

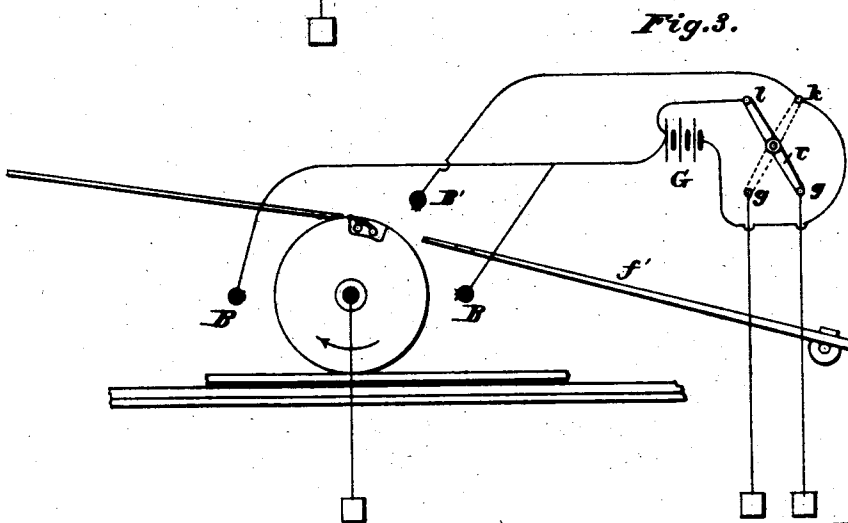
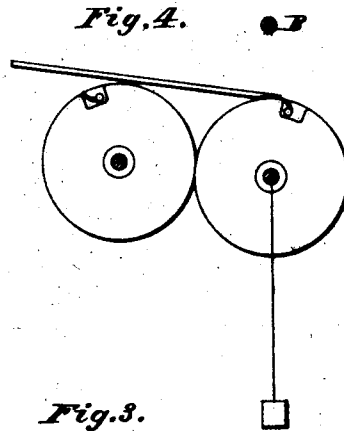
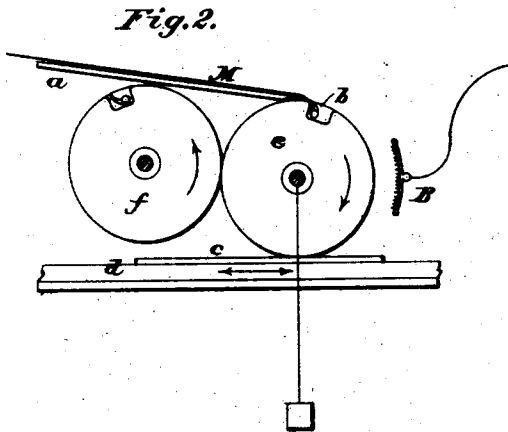
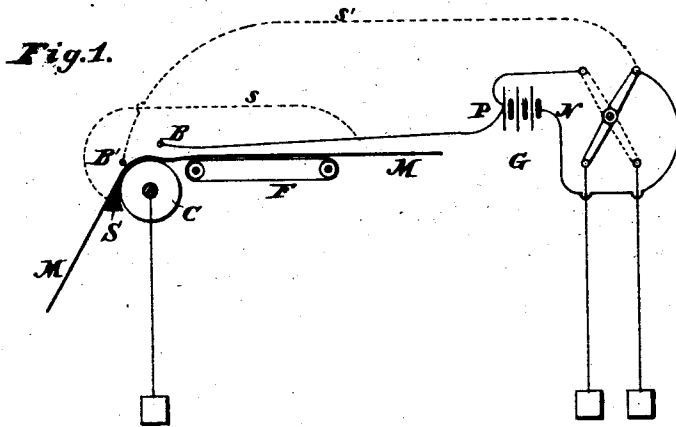

Attest:
 Court A. Cooper
 C. B. Pumphrey.

Inventor:
 John W. Osborne
 by Foster & Sullivan
 attys

(No Model.)

2 Sheets—Sheet 2.

J. W. OSBORNE.

ELECTRICAL APPARATUS FOR AND METHOD OF CONTROLLING PAPER, &c.

No. 287,957.

Patented Nov. 6, 1883.

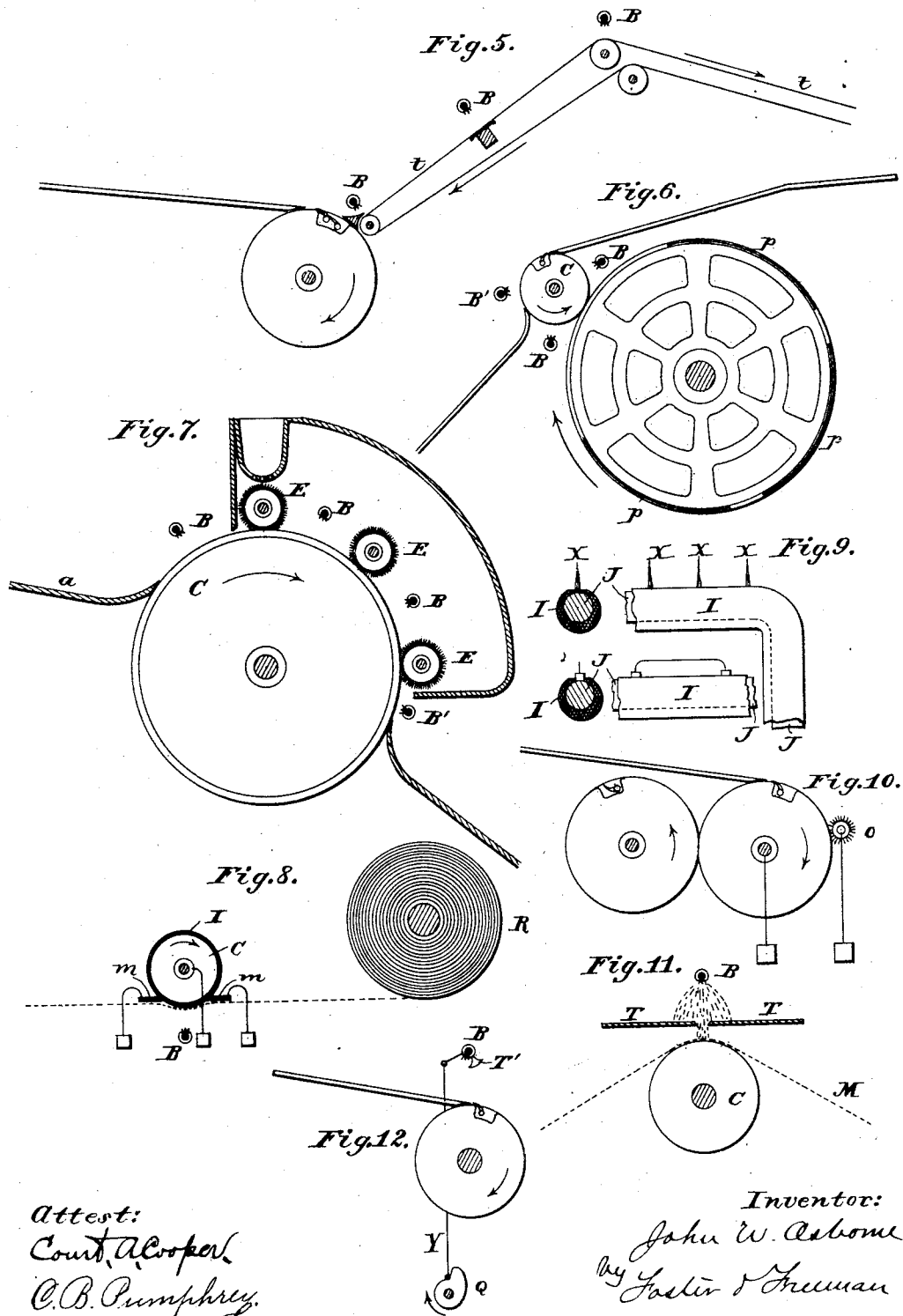

Attest:
 Count. Al Cooper
 C. B. Pumphrey.

Inventor:
 John W. Osborne
 by Foster & Freeman

UNITED STATES PATENT OFFICE.

JOHN W. OSBORNE, OF WASHINGTON, DISTRICT OF COLUMBIA, ASSIGNOR
TO WILLIAM H. FORBES, OF BOSTON, MASSACHUSETTS.

ELECTRICAL APPARATUS FOR AND METHOD OF CONTROLLING PAPER, &c.

SPECIFICATION forming part of Letters Patent No. 287,957, dated November 6, 1883.

Application filed September 21, 1883. (No model.)

To all whom it may concern:

Be it known that I, JOHN W. OSBORNE, a subject of the Queen of Great Britain, now residing at the city of Washington, in the District of Columbia, United States of America, have invented certain new and useful Improvements in Electrical Apparatus for and Method of Controlling Paper and other Materials, of which the following is a specification.

Heretofore it has been the common practice to use mechanical means for controlling paper and other materials in holding, feeding, and delivering the same in various machines, such as printing and embossing presses, bronzing-machines, and the like. These means consist, ordinarily, of grippers, fingers, tapes, feed-rollers, and similar devices, all of which more or less disfigure the material operated upon, and at the same time fail to produce that intimate contact or adhesion between the material fed and the feeding devices that is desirable. This difficulty has been partly overcome by the use of pneumatic devices; but the production of the vacuum or plenum necessary to produce the desired result requires a great expenditure of energy, and the adhesive force thus obtained is not easily controlled.

The object of my present invention is to overcome these difficulties by substituting for these means, in whole or in part, electrical devices; and to this end my invention consists, broadly, in the utilization of the attraction which bodies have for each other when charged with electricity of opposite polarities, and the repulsion which they manifest when charged with electricity of the same polarity, for the purposes of holding, feeding, and delivering paper and other materials.

In carrying out my invention I produce the necessary adhesion between the material controlled and the operating devices by imparting by conduction or convection a charge of one polarity to one and a charge of the opposite polarity to the other from any source of electricity; or I may impart by conduction or convection a charge of one polarity either to the material or the operating devices, and a charge of opposite polarity to the other by induction. I am thus enabled to secure a close and strong adhesion at the desired points between the paper or other material and the

operating devices, and also the necessary repulsion where required, as will hereinafter more fully appear.

As a source of electricity, an ordinary frictional generator, an influence-machine, an induction-coil, a magneto-electric generator, or a battery of high potential, or, in fact, any apparatus adapted to furnish the necessary electric charge, is used. One pole of the generator is connected with or brought into proximity to the material to be operated upon, which thus receives a charge of one polarity. The other pole of the generator may either be connected directly or brought into proximity with the support of the material, which thus receives the charge of opposite polarity directly; or the said pole may be grounded, and the support of the material thus receive its charge by induction. Ordinarily, it will be necessary to connect the support electrically also with the ground. This is found in practice to be the most convenient arrangement. In order to overcome at the desired time the adhesion thus produced between the material and its support, I make use of the diffusion of the charge into the air, and I discharge the support into the ground. In some instances where the discharge of itself is insufficient to promptly overcome the adhesion, it may be aided by producing charges of the same polarity both in the material and the support at the desired points, thus producing a repulsion between the material and its support.

In order to more particularly describe and illustrate my invention, reference is made to the accompanying drawings, forming part of this specification, wherein I have shown, principally diagrammatically, the application of my invention as a substitute for and auxiliary to the ordinary means of controlling sheets and webs of material through various machines, and in which—

Figure 1 is a diagram illustrating the principle of my invention. Figs. 2, 3, 4, 5, and 6 show diagrammatically my invention as applied to various styles of printing-machines. Fig. 7 shows it applied to a bronzing-machine. Fig. 8 shows it applied to the feeding of semi-conducting webs of paper or similar material. Fig. 9 shows the preferred forms of emitters in cross-sections and side views. Fig. 10 shows

my invention as applied when the charge is generated at the point required, and Figs. 11 and 12 show means for reducing and controlling the field of charge.

5 In Fig. 1, I have shown at G a conventional sign for a generator, the preferred form of which consists of an influence-machine of the kind known as a "Holtz" machine, improved by Wimshurst, which may be driven by the
10 same power that drives the machine. The prime conductors of said machine, P and N, are connected one by insulated wire to the pointed or comb-like charging-brush B and the other to the ground. A rotating roll or cylinder, C,
15 driven by suitable power, is here shown as a type of a feeding or carrying roller of any machine through which paper or other material is passed in the operations of printing, embossing, coloring, bronzing, &c.
20 The web or sheet of material, M, which may be delivered to the cylinder C by any well-known means, as shown at F, which represents an endless apron or tape, passes before or in front of the brush B and receives a
25 charge of electricity—in this case positive. The cylinder is made either of metal or may consist of a metal shell covered with insulating material, and is in both instances properly connected electrically with the ground.
30 A stripper, S, of conducting or non-conducting material, may be used. At the moment the material touches the cylinder, it will closely adhere to it, whether the same be entirely of metal or of metal covered with insulating material. If entirely of metal, the paper or other
35 slightly-conducting material will charge the cylinder by conduction, which charge is, however, instantly carried off to the ground, and it will also act inductively upon the same, repelling the electricity of the same polarity—in
40 this instance to the ground—and attracting and holding the electricity of opposite polarity—in this instance negative. Thus if the supply from the primary source were now interrupted, the material would for a short time adhere to the
45 cylinder until it was discharged to the ground or surrounding air. Since, however, the supply from the source is continuous, the material will continue to adhere to the cylinder, and
50 will be carried around by the same until stripped off mechanically by the stripper S, when used, or otherwise. When the metal cylinder is covered with insulating material, the operation will be similar, except as modified
55 by the greatly-diminished conduction from the paper to the cylinder, and the increased induction, which again is modified by the thickness of the non-conducting material. In some instances the action of the stripper is aided by imparting to it a charge of the same polarity
60 as that received by the paper, as by a branch wire, s, connecting the prime conductor with the stripper; and the stripper may sometimes be entirely dispensed with by charging the
65 paper at the point it is desired that it should leave the cylinder with electricity of opposite polarity by means of a brush, B', connected

to the opposite pole of the generator by the conductor s', whereby at this point a repulsion between the paper and cylinder may be effected. From this it will be seen that by my invention I am enabled to feed, hold, and deliver paper and other material without the aid of the ordinary mechanical gripping or controlling devices.

70 The force of the adhesion of the material to the cylinder depends upon the charge received by the material, which in turn depends upon the electrical tension in the prime conductor, the quantity of electricity emanating from the points or brushes, and the distance of the latter from the material.
75

In Fig. 2, I have shown my improvement as applied to a typical cylinder-press provided with the usual gripping devices and used as an adjunct thereto. In these presses only one edge of the paper is positively held by the gripping devices, and it has been found necessary to provide special means for preventing the body of the sheet from shifting or flapping during its passage from the feed-board to the delivery apparatus. I overcome this difficulty by my invention by charging the sheet of paper or other material as it passes from the feed-board to the cylinder by means similar to those described in connection with Fig. 1. Referring to the figure, e is the impression-cylinder; b, the gripper holding the forward end of the sheet M. a is the feed board. c is the form upon the moving bed d, and f is the delivery-cylinder. B is a brush connected to one pole of the generator, the cylinder being grounded, as in Fig. 1.
85
90
95
100

The operation is as follows: The sheet is fed from the feed-board to the gripper on the impression-cylinder in any usual manner, and is carried around in the direction shown by the arrow in front of the brush. It thus receives a charge of electricity, and in the manner described with reference to Fig. 1 it will strongly adhere to the cylinder until the impression is made, by which time the charge will be partly dissipated into the air or discharged through the machine, so that it will be easily delivered by any common delivery apparatus.
105
110
115

In Fig. 3 is shown an application of my invention to what is known as a "continuous-revolution" printing-press. In these machines the paper is carried around by the cylinder, and is then delivered to a fly or other delivery apparatus. It is therefore desirable that the paper should adhere to the cylinder both before and after the impression, and should then be disengaged from the cylinder. To accomplish this I provide, in addition to the ordinary grippers, brushes B, B' on opposite sides of the cylinder, which may be connected to one pole of the generator, and a brush, B', located at the point of delivery of the sheet to the fly f', and is connected to a conductor which terminates in a contact, k. Beyond the striking distance of the machine and insulated from the plate k is another contact, l, which is connected to the brushes B. The poles of
120
125
130

the generator are also connected to the contacts *k l*, and the contacts *g g* are connected to the ground. A switch, *r*, is arranged to make contact with either of the two contact-plates *k l* and the ground. This switch is operated by mechanism timed so as to produce the charge in *B'* just at the moment the sheet is to be delivered upon the fly, and after the delivery of the paper to re-establish contact with *l*. This operating mechanism may be connected to that operating the fly, or to any other desired or convenient part of the mechanism. The operation of this arrangement requires no special description.

In Fig. 4, I have shown, diagrammatically, the application of my invention to a cylinder-press wherein the sheets are fed to the impression-cylinder from an ordinary feed-board, the charging-brush *B* being so located as to charge the paper as it is being drawn from the board by the grippers. Thus the charged paper is forcibly drawn from the feed-board and passes onto the cylinder under tension, insuring its close contact with the same and avoidance of all wrinkles or other irregularities.

In Fig. 5 is shown, diagrammatically, a delivery apparatus consisting of cords, tapes, or belts passing over the usual guide-rolls. The paper as it is delivered from the impression-cylinder in any usual manner is passed to the tapes *t*, and there receives a charge from the brushes *B*, located above each roller or support, which are preferably arranged at distances apart not exceeding the length of the sheet, if sheets are used. The necessary adhesion of the paper to the feeding devices being thereby secured, the paper is delivered in the usual manner.

In Fig. 6, I have shown the application of two or more charging-brushes on opposite sides of an impression-cylinder of a multiple-color press. The printing-forms *p* in this case are curved, and are disposed about a large cylinder. This form-cylinder rotates in contact with the impression-cylinder *C*, on which the sheet to be printed is held while the inked forms are passing, so that all the colors are printed in proper sequence on the same side of the same sheet. In a press of this sort there is no difficulty in laying hold of the leading edge of the sheet by grippers on the impression-cylinder; but as the latter is usually of small diameter, it is not easy to hold the tail of the sheet in perfect contact with the cylinder-face, so as to insure good register and keep the inked surface of the paper from flapping and smearing itself. I accomplish this result by locating a charging-brush *B* before and behind the cylinder, whereby the charge in the paper and its adhesion to the cylinder are maintained throughout the rotation of the impression-cylinder. A brush *B'*, for neutralizing or reversing the charge, is located at the point of delivery of the sheet, and is connected with the generator and brought into action substantially in the manner described with reference to Fig. 3.

In Fig. 7 is shown in outline a bronzing-machine with my invention applied thereto. From the feed-board *a* the paper passes to the drum *C*, where it is held by the charges received from the brushes *B B*, and is carried under the bronzing and polishing rollers *E*. A brush *B'*, for neutralizing or reversing the charge, is located at the point of delivery.

In Fig. 8, I have shown the means for feeding a web of more or less conducting material—such, for instance, as damp paper—to any kind of a machine. *R* is a roll of material to be fed. The cylinder or feed-roll *C* is in this instance covered with a layer of insulating material, *I*, and upon each side of the cylinder in the line of feed are metallic plates *m*. A brush *B* is located so as to charge the paper when it passes over the roller. By contact of the damp paper with the plates *m*, which are properly grounded, a portion of the charge is lost; but enough of it remains to charge the cylinder *C* by induction, so as to cause the paper to adhere to the same and be carried along as the cylinder revolves.

I have found that the interposition of any screen between the emanating-points and the surface which supports the material to be held intercepts the electrical radiation, causing an "electrical shadow," as it may be called, to fall upon the paper or other substance, within which no adhesion takes place. I utilize this fact in limiting or controlling the extent of the field of charge or for entirely cutting the same off.

In Fig. 11 the web *M* is fed forward by reason of its adhesion to the cylinder or roll *G*. To prevent the wider extension of the emanation from the points above the web, (whereby the field of adhesion may extend somewhat beyond that part which is in contact with the roll and cause it to deviate from the true tangential position,) I place the shields or screens *T T* as shown. If by the dotted lines emanating from the brush *B* the cone of electrical influence is indicated, these screens *T T* will be joined, to reduce the field of charge upon the cylinder, in the manner indicated, so that only a limited strip of the web adheres, the width of which depends on the proximity of the plates *T T*. In some respects, therefore, these plates play the part of strippers, and I have found that their office for this and other purposes is satisfactorily performed, whether they are made of non-conducting or conducting material, and whether the latter is grounded or not.

In Fig. 12 the interposition of a screen at the proper moment is made to perform useful work in conjunction with the method hereinbefore described for holding or retarding the sheets fed from a feed-board to the grippers of an impression-cylinder. In performing this function the screen obviates the necessity for an automatic switch, the introduction and working of which may not be at all times convenient. The shield *T'* swings on bearings coincident with the axis of the emanator *B*, and when the cam *Q* raises the rod *Y* it moves the

arm connected with the screen, whereby the same drops and cuts off all emanation from the brush, so that it will not reach the feed-board.

While the screen is in this position, the sheet
5 can be moved in every direction, and the feeder is enabled to place it properly up to the stops and guides. The cam-rod Y or an equivalent device then drops and causes the removal of the screen, whereupon the adhesion is immediately established and the sheet
10 resists the pull of the cylinder, as before.

Fig. 9 shows in cross-section and side elevation portions of an emanating or radiating conductor such as I usually employ, in which
15 J is the metallic core, I the insulating-envelope, and X the emanating points or loops. Instead of using points or loops, in some instances knife-edges may be used for radiators. The brushes or emission-points may be made
20 of flaxen threads or fibers, the flax being a conductor to some extent.

In the application of my invention so far described I have assumed the use of an independently-operated generator, and the electric charge was carried to the machines by conductors. I may, however, in some instances generate the electricity required directly upon the material to be fed or upon the feeding devices. In Fig. 10, I have shown one form of
30 such a device, in which a revolving exciting-rubber, o, covered with fur or other equivalent material, bears upon the material fed. The electric charge is thus generated directly at the point required in a manner well understood in the art.
35

It will be understood that I do not confine myself to the application of my invention to any particular machine, nor to the particular details herein set forth, as I consider my invention as applicable to all machines through
40 which sheets, laminae, or webs of paper, cloth, and other materials are fed, and the details of construction and arrangement may be varied in a great number of ways, to suit the exigencies of the occasion, so long as the fundamental principles involved are observed.
45

To illustrate some of the more apparent modifications it may be remarked that it is not necessary in many instances to provide
50 special devices for grounding the machine, as the machine itself will be sufficiently connected with the ground. In place of intimate ground-conductors, as shown, pointed grounded conductors may be disposed about the machine.
55 In some instances, where fingers are used in delivering, it will be desirable to make them conductors, and to connect them also to the ground. The close proximity of the charging-brushes to the paper is not necessary; nor is
60 a large number of emission-points to the brushes necessary, a single point producing very considerable effects and covering a wide area on the paper, if not too close. I have found that a fine wire, preferably bent into a loop and made
65 part of the charging-conductor, forms an excellent radiator. The fineness of the wire should be so proportioned to the charge that

it will appear luminous in the dark, due to the electric radiation. The number of charging-brushes and the distribution of the same in
70 any machine will depend upon the quantity of electrical charge required, the amount of dissipation due to the conditions of the atmosphere, and leakage due to imperfect insulation, and many other circumstances which it is not
75 deemed necessary to recite. In delivering the material, instead of reversing the charge, grounded points or metallic brushes may be located in proximity to the points of discharge, and when a metallic stripper is used it may be
80 simply grounded.

I claim—

1. The method, substantially as hereinbefore set forth, of controlling sheets or webs of paper or other materials upon a support, which
85 consists in imparting to such material and support charges of electricity of proper polarity, whereby the necessary attraction is produced.

2. The method, substantially as hereinbefore set forth, of controlling sheets or webs of paper or other material upon a support, which
90 consists in imparting to such material and support charges of electricity of the proper polarity, whereby the desired attraction or repulsion is produced.
95

3. The method hereinbefore set forth of holding sheets or webs of paper and other materials to a support in its passage through a machine, which consists in charging the material with electricity of one polarity and the support
100 with electricity of the opposite polarity.

4. The method, substantially as hereinbefore set forth, of controlling sheets or webs of paper or other material during its passage through a machine, which consists in producing charges
105 of electricity of opposite polarity in the material and support, respectively, and whereby the necessary adhesion is produced between the two.

5. The method, substantially as hereinbefore set forth, of holding and delivering sheets or webs of paper, &c., which consists in producing charges of electricity of opposite polarity in the material and support, respectively, and
110 utilizing the adhesion thus produced between the two to hold the material, and in neutralizing or dispersing said charges, to overcome the adhesion and deliver the material.
115

6. The method, substantially as hereinbefore set forth, of feeding, holding, and delivering
120 sheets or webs of paper and other material, which consists in producing charges of electricity of opposite polarities in the material and support, respectively, and utilizing the adhesion thus produced between the two to
125 hold and feed the material, and neutralizing such adhesion by reversing the polarity of the charge in one to deliver the material.

7. The method, substantially as hereinbefore set forth, of holding, feeding, and controlling
130 sheets or webs of paper and other materials upon a roll or cylinder, which consists in continually producing a charge of electricity of one polarity in the material and a charge

of the opposite polarity in the roll or cylinder.

8. In a machine for feeding, holding, or delivering sheets or webs of paper or other materials, the combination, with a support for the material and a source of electricity, of means for producing a charge of electricity in the support and the material, substantially as described.

9. In a machine for feeding, holding, or delivering sheets or webs of paper or other material, the combination, with a support for the material, of a source of electricity, and means for producing in the support and material charges of electricity of opposite polarity, respectively, substantially as described.

10. In a machine for feeding, holding, or controlling sheets or webs of paper or other material, the combination, with a support for the material and a generator of electricity, of means for producing in the support and material charges of electricity of opposite polarity, and means for neutralizing the charge, substantially as described.

11. In a machine for feeding, holding, or controlling sheets or webs of paper or other material, the combination, with a support for the material and a generator of electricity, of means for producing in the support and material charges of electricity of opposite polarity, and means for producing charges of the same polarity in the support and material, whereby the material may be held to the support by the adhesion due to bodies charged with electricity of opposite potentials, and delivered by the aid of the repulsion due to bodies charged with like polarity.

12. In a machine for feeding, holding, and controlling sheets or webs of paper or other material, the combination, with a feed or carrying roller or cylinder, of a generator of electricity, and a radiator or emission-point connected to the generator, and arranged so as to produce charges of electricity in the material.

13. In a machine for feeding, holding, or controlling sheets or webs of paper or other material, the combination, with a feed or carrying roller or cylinder, of a generator of electricity, a radiator or emission-point connected with the generator, and a stripping or delivering device.

14. In a machine for feeding, holding, or controlling sheets or webs of paper or other material, the combination, with a feed or carrying roller or cylinder, of a generator of electricity, a radiator or emission-point connected with the generator, and a stripping or delivering device, connections from the delivery device to the generator, and means whereby either or both radiator or delivery device may be connected to either pole of the generator.

15. The combination, with a support and a generator of electricity, of radiators or emission-points, and screens for interposition between the radiator and support, substantially as described.

16. The method, substantially as hereinbefore set forth, of controlling paper and other materials, which consists in charging the support or material with electricity and intercepting the electricity, or screening the support or material from the influences of electrical emanations from the charging device.

17. The method, substantially as herein set forth, of controlling paper or other material upon a support, which consists in directly charging the material with electricity of the desired polarity and producing a charge of the desired polarity in the support.

18. The method, substantially as herein set forth, of controlling paper and other material on a support, which consists in directly and continuously charging the material with electricity of the desired polarity from the source of supply and charging the support by induction.

19. The method, substantially as herein set forth, of controlling paper or other material, which consists in retarding, hindering, or restraining the free passage of the material to a device by which it is seized or to which it is fed by the creation of friction due to the attraction between bodies charged with electricity.

In testimony whereof I have signed my name to this specification in the presence of two subscribing witnesses.

JOHN W. OSBORNE.

Witnesses:

CHARLES E. FOSTER,
FRANK L. FREEMAN.