

(19) World Intellectual Property Organization
International Bureau



(43) International Publication Date
15 January 2009 (15.01.2009)

PCT

(10) International Publication Number
WO 2009/009794 A1

(51) International Patent Classification:
H04R 25/00 (2006.01)

(21) International Application Number:
PCT/US2008/069981

(22) International Filing Date: 14 July 2008 (14.07.2008)

(25) Filing Language: English

(26) Publication Language: English

(30) Priority Data:
60/949,398 12 July 2007 (12.07.2007) US

(71) Applicant (for all designated States except US): **PERSONICS HOLDINGS INC.** [US/US]; 5200 Town Center Circle Tower II, Suite 510, Boca Raton, Florida 33486 (US).

(72) Inventors; and

(75) Inventors/Applicants (for US only): **GOLDSTEIN, Steven Wayne** [US/US]; 6390 Maddalena Place, Delray Beach, Florida 33446 (US). **KEADY, John** [US/US]; 5100 Town Center Circle Tower II, Suite 510, Boca Raton, Florida 33486 (US).

(74) Agents: **KURTZ, Richard** et al.; Greenberg Traurig LLC, 2101 L Street, NW, Suite 1000, Washington, DC 20037 (US).

(81) Designated States (unless otherwise indicated, for every kind of national protection available): AE, AG, AL, AM, AO, AT, AU, AZ, BA, BB, BG, BH, BR, BW, BY, BZ, CA, CH, CN, CO, CR, CU, CZ, DE, DK, DM, DO, DZ, EC, EE, EG, ES, FI, GB, GD, GE, GH, GM, GT, HN, HR, HU, ID, IL, IN, IS, JP, KE, KG, KM, KN, KP, KR, KZ, LA, LC, LK, LR, LS, LT, LU, LY, MA, MD, ME, MG, MK, MN, MW, MX, MY, MZ, NA, NG, NI, NO, NZ, OM, PG, PH, PL, PT, RO, RS, RU, SC, SD, SE, SG, SK, SL, SM, ST, SV, SY, TJ, TM, TN, TR, TT, TZ, UA, UG, US, UZ, VC, VN, ZA, ZM, ZW.

(84) Designated States (unless otherwise indicated, for every kind of regional protection available): ARIPO (BW, GH, GM, KE, LS, MW, MZ, NA, SD, SL, SZ, TZ, UG, ZM, ZW), Eurasian (AM, AZ, BY, KG, KZ, MD, RU, TJ, TM), European (AT, BE, BG, CH, CY, CZ, DE, DK, EE, ES, FI, FR, GB, GR, HR, HU, IE, IS, IT, LT, LU, LV, MC, MT, NL, NO, PL, PT, RO, SE, SI, SK, TR), OAPI (BF, BJ, CF, CG, CI, CM, GA, GN, GQ, GW, ML, MR, NE, SN, TD, TG).

Published:
— with international search report

(54) Title: EXPANDABLE EARPIECE SEALING DEVICES AND METHODS

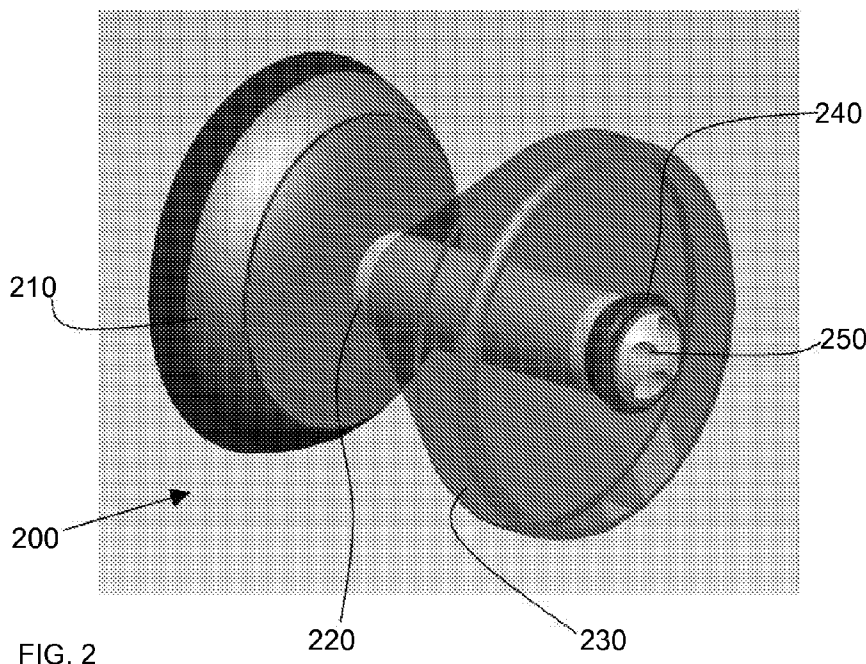

FIG. 2

(57) Abstract: At least one exemplary embodiment is directed toward an earpiece with a sealing section for acoustically sealing the meatus of a human ear, which includes an inner ear canal speaker; an inner ear canal microphone; connected to a logic circuit which can include a digital signal processor (DSP), where the sealing section touches a portion of the ear canal to substantially acoustically seal the meatus of a human ear canal.



WO 2009/009794 A1

EXPANDABLE EARPIECE SEALING DEVICES AND METHODS

FIELD OF THE INVENTION

[0001] The invention relates in general to devices and methods of earphone, earpiece, earbud, fit and sealing technology, and particularly though not exclusively, is related to expandable sealing mechanisms for earpieces.

BACKGROUND OF THE INVENTION

[0002] Present day ear devices are intended to deliver information to the ear via off-the-shelf or custom-molded pieces that present the information primarily in the outer third of the ear canal, often with questionable attention to the actual fit, comfort, and consideration of the ear anatomy and physiology.

[0003] Current systems do not use inflatable or expandable systems to achieve sound isolation and sealing.

SUMMARY OF THE INVENTION

[0004] At least one exemplary embodiment is related to an earpiece (e.g., earphone, earbud, or other devices configured to direct acoustic signals to the ear) inserted into the ear canal, where a portion of a sealant section acoustically seals a medial portion of the external auditory canal.

[0005] At least one exemplary embodiment is directed to an earpiece that includes: a sealing section, where the sealing section includes an expandable bladder; an ambient sound microphone (ASM); an ear canal receiver (ECR); an

ear canal microphone (ECM); a wireless communication module; a power source; and a logic circuit.

[0006] Further areas of applicability of embodiments of the present invention will become apparent from the detailed description provided hereinafter. It should be understood that the detailed description and specific examples, while indicating exemplary embodiments of the invention, are intended for purposes of illustration only and are not intended to limit the scope of the invention.

BRIEF DESCRIPTION OF THE DRAWINGS

[0007] Exemplary embodiments of the present invention will become apparent from the following detailed description taken in conjunction with the following drawings., wherein:

[0008] Figure 1 illustrates an ear canal as a non-limiting example of an orifice that can be sealed with an earpiece according to at least one exemplary embodiment;

[0009] Figure 2 illustrates an orifice insertion device according to at least one embodiment;

[0010] Figures 3 and 4 illustrate a stent used to inflate an expandable section of the device;

[0011] Figure 5 illustrates a multiple expandable system where various combinations of expandable systems can be combined on a stent;

[0012] Figure 6 illustrates an internal piston mechanism that can be used to increase the pressure in the inflatable membrane on a stent.

DETAILED DESCRIPTION

[0013] The following description of exemplary embodiment(s) is merely illustrative in nature and is in no way intended to limit the invention, its application, or uses.

[0014] Exemplary embodiments are directed to or can be operatively used on various wired or wireless earpiece devices (e.g., earbuds, headphones, ear terminal, hearing aids, behind the ear devices, or other acoustic devices as known by one of ordinary skill in the art, and equivalents).

[0015] Processes, techniques, apparatus, and materials as known by one of ordinary skill in the art may not be discussed in detail but are intended to be part of the enabling description where appropriate. For example material fabrication may not be disclosed, nor attachment procedures (e.g., adhesive attaching of separate ridge structures), but such, as known by one of ordinary skill in such arts is intended to be included in the discussion herein when necessary.

[0016] Notice that similar reference numerals and letters refer to similar items in the following figures, and thus once an item is defined in one figure, it may not be discussed or further defined in the following figures.

[0017] Figure 1 illustrates a sealed (occluded) ear canal 50, with a sealed volume 30. Voice can leak 80 into the sealed volume 30 from various source paths 80A, 80B, and 80C. In one explanation, the leaked acoustic energy results in an amplification (e.g., by resonance) at certain frequencies within the sealed volume, resulting in the Occlusion Effect. If the ear canal (a non-limiting example of an orifice) was unsealed then no resonance could build and hence there would be no Occlusion Effect. While the present invention

has been described with reference to exemplary embodiments, it is to be understood that the invention is not limited to the disclosed exemplary embodiments. The scope of the following claims is to be accorded the broadest interpretation so as to encompass all modifications, equivalent structures and functions of the relevant exemplary embodiments.

[0018] Figure 1 illustrates at least one exemplary embodiment. An earpiece 100 can include an insertion element 75 operatively connected to a sealing section. The sealing section can include an expandable section 70 (e.g., expanding polymers, inflatable systems, mechanically expanded systems).

[0019] The expandable section 70 can be inflatable (e.g., fluid (gas or liquid)) of deformable fillable material. For example the fillable material referred to herein can be viscous and can include silicone-based polymers, gels, vinyl elastomers, or any other material of sufficient properties to allow the deformation of a membrane cavity from user contact. Materials can also be used to provide a slow reformation of the original membrane cavity shape after it has been deformed and released. In this regard, a silicone gel or other non-cross-linked polymer or uncatalyzed materials may be used. It should be appreciated that the composition of the fillable material could be altered for applications in which varied membrane characteristics are desired (i.e. more stiffness, durability, more or less deformability and/or longer-lasting deformation). The fillable material may be elastically deformed or it may be deformed by displacement, which is the actual movement or flow of the fillable material in response to pressure, such as that from a user's fingertips. In addition, the fillable material could be altered for applications in which varied

temperature or light conditions would be encountered during the use of particular products on which the membrane cavity is mounted.

[0020] The portion of a membrane connected to a structure (base membrane) can be made of any material, rigid or elastic, including various plastic or metal materials, or it can be made of a membrane formed of thin rubber-based material, deformable plastic or silicone-based materials or other elastomeric materials suitable for a given application. If the base is configured as a flexible membrane, the cavity can more easily conform to a product's surface, thereby increasing the ease with which the cavity can be installed, removed, and replaced. Likewise, the outer membrane also can be made of a thin rubber-based material, deformable plastic or silicone polymer materials, or other elastomeric materials suitable for a given application. If the base membrane and outer membrane are made of silicone material, both should be from 0.50 mm to 2.5 mm in thickness. In this regard, the base may be a membrane instead of a piece of rigid material. The edges of the outer membrane and the base membrane can be mechanically fastened or clamped forming the membrane cavity. Additionally, at least a portion of the base membrane can be adhesively attached (e.g., adhesive tape, glue) or mechanically fastened to the support structure.

[0021] The silicone sealant can be of an acetoxycure type. In particular, upon exposure to moisture, the silicone sealant will give off small amounts of acetic acid while the sealant cures. It is not recommended that the acetic acid vapors be inhaled. The sealant will cure in 24 hours and has a tack free time of 10-20 minutes at 77.degree. F. (25.degree. C.) with 50% relative humidity. The sealant's tensile strength is approximately 350 psi, its elongation property

is 450%, and its hardness is approximately 25-30 Shore A. The sealant has temperature stability from -85.degree. F. to 450.degree. F. (-65.degree. C. to 232.degree. C.) and can withstand intermittent exposure to temperatures as high as 500.degree. F. (280.degree. C.). The sealant is believed to have good resistance to various weathering conditions, including UV radiation, rain, snow, etc, without hardening, cracking, or shrinking.

[0022] For optimum adhesion with the above adhesive, the support structure and the lower surface of the base membrane should be clean, dry, and free from oil, grease or other foreign material. If necessary, metal surfaces should be wiped with a non-oily solvent. Rubber surfaces should be abraded to promote adhesion. Depending on environmental conditions, the base and product surface should be joined within 5-10 minutes, before the tack-free time of the sealant passes.

[0023] If the expandable section 70 includes a fluid (gas or liquid) the fluid can be variable for example H₂, O₂, air, and water, where the membrane can be designed to vary porosity to the fluid leakage through the membrane. For example for some gases (e.g., H₂) the wall thickness can be increased (e.g., 3 times that of air) to decrease the porosity of H₂ through an inflatable membrane.

[0024] Typical dimensions of the expandable section include a fully expanded dimension that is slightly larger than the orifice (e.g., nose, throat, vein, anal, ear canal) opening.

[0025] Figure 2 illustrates an orifice insertion device 200, that has an optional stop flange 210. The stop flange 210 can be designed to stop at the opening of an orifice. The stop flange 210 can be attached to a stent (e.g.,

multilumen tube, single lumen tube) that can vary in durometer (e.g., 25-80 urethane, steel, wood). As illustrated in Figure 2 the stent 220 is a multi-lumen tube with various openings (e.g., 250). An expandable section 230 can be operatively attached to the stent 220 (e.g., heat bonded, shrink wrapped, glued). Optionally a guide section 240 (e.g., soft foam tip, additional inflatable system) can be attached near the end of the stent 220 to aid in the insertion of the orifice device 200 (e.g., earpiece).

[0026] In an embodiment, the expandable section of the earpiece is an inflatable device. Several methods can be used to inflate the expandable section. For example Figures 3 and 4 illustrate a stent 320, operatively connected to an inflatable membrane 310 (e.g., balloon), where a push mechanism (340 + 360) move along the stent A1, to compress B1 the inflatable membrane 310. Additionally Figure 6 illustrates an internal piston 620 mechanism that can be used (e.g., moved D1) to increase the pressure E1 in the inflatable membrane 610 on a stent 630.

[0027] Figure 5 illustrates a multiple expandable system where various combinations of expandable systems (e.g., one inflatable the other foam), can be combined on a stent 520. The orifice insertion device 500 illustrated in Figure 5 shows two expandable section 530A and 530B. Both can be expanded by methods discussed previously and at different times. For example expandable section 530A can be inflated (if it were an inflatable system) if a trigger event (e.g., excess sound pressure level (e.g., 100dB)) were reached.

[0028] In the examples illustrated above the sealing sections have been illustrated as homogeneous material, which in some cases which can expand

in response to thermal variations. Additional exemplary embodiments can include expandable sections, that can include temperature expanding materials varying in a sandwich type configuration, and/or an expandable membrane or bladder that is expanded to touch and press against the ear canal wall to provide sealing. In addition to varying penetration into the depths of the ear canal for various devices, at least one exemplary embodiment includes an earpiece device that seals near the concha or the external auditory meatus. For example the earpiece device can have a concha support piece to which is attached an ear terminal (portion penetrating into the ear canal), where the ear terminal seals and seats near the external auditory meatus.

[0029] In at least one exemplary embodiment the compression can be driven by a piston, where the piston can be driven by a linear actuator or via pneumatic system where an incompressible fluid presses against one side of the piston forcing it in a direction compressing the bladder.

[0030] Additional exemplary embodiments can use an expandable bladder as a sealing section where one side of an inner wall moves as driven by actuators, gears, pneumatics or other methods as one of ordinary skill would know, and presses on the bladder expanding the bladder into the ear canal. The bladder can be attached to the moveable wall so that retraction of the wall retracts the bladder from the ear canal.

[0031] At least one exemplary embodiment is directed to an orifice insertion device comprising: a stent; and a sealing element where the sealing element is operatively attached to the stent, wherein the sealing element includes at least a first expandable section, where the expandable section is

configured to exert a pressure on an orifice wall sufficient to seal the orifice without appreciable deformation of the orifice wall. The pressure exerted can vary depending upon the orifice wall's material composition and rigidity. For example in flesh the pressure exerted can lie between 1 atmospheres and 5 atmospheres, where an atmosphere is the pressure at sea level.

[0032] While the present invention has been described with reference to exemplary embodiments, it is to be understood that the invention is not limited to the disclosed exemplary embodiments. The scope of the following claims is to be accorded the broadest interpretation so as to encompass all such modifications and equivalent structures and functions.

CLAIMS

What is claimed is:

1. An orifice insertion device comprising:
 - a stent; and
 - a sealing element where the sealing element is operatively attached to the stent, wherein the sealing element includes at least a first expandable section, where the expandable section is configured to exert a pressure on an orifice wall sufficient to seal the orifice without appreciable deformation of the orifice wall.

2. The orifice insertion device according to claim 1 where the device is an earpiece, further comprising:
 - a first microphone;
 - a second microphone;
 - a receiver, wherein the first microphone, the second microphone, and the receiver are operatively connected via a support structure, where the expandable section is a membrane that expands to press against a portion of an ear canal wall.

3. The orifice insertion device according to claim 2, where the membrane is a bladder and contains a fluid.

4. The orifice insertion device according to claim 3, where the fluid is gas.

5. The orifice insertion device according to claim 2, where the membrane expands in a first direction in response to pressure in a second direction.
6. The orifice insertion device according to claim 5, where the pressure is caused by a mechanical pressure.
7. The orifice insertion device according to claim 6, where the mechanical pressure is caused by a pneumatic fluid piston system.
8. The orifice insertion device according to claim 6, where the mechanical pressure is caused by a mechanical element pressing on the bladder.
9. The orifice insertion device according to claim 8, where after expansion the mechanical element locks to maintain expansion.
10. The orifice insertion device according to claim 9, where the earpiece device further includes:
 - a second sealing section, where the second sealing second is configured to press against a second portion of the ear canal, where the second portion is different from the portion.
11. The orifice insertion device according to claim 1, where the pressure is between 1 atmosphere at sea level and 3 atmospheres at sea level.

12. The orifice insertion device according to claim 1, where the pressure is greater than 1 atmosphere at sea level and less than 1.75 atmospheres at sea level.

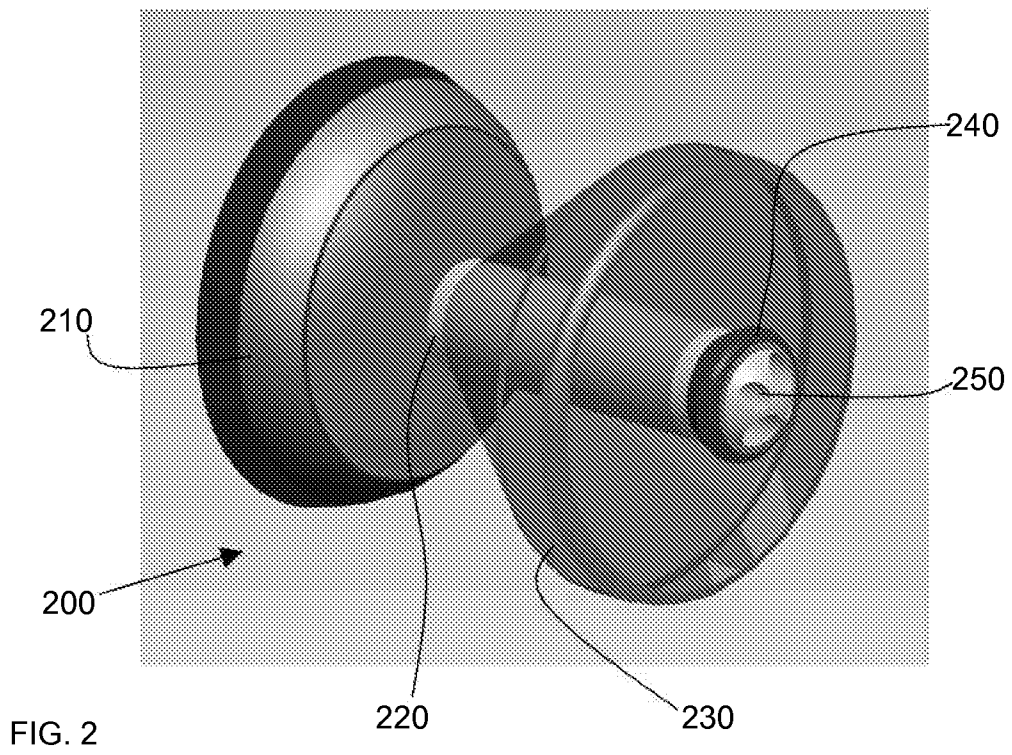
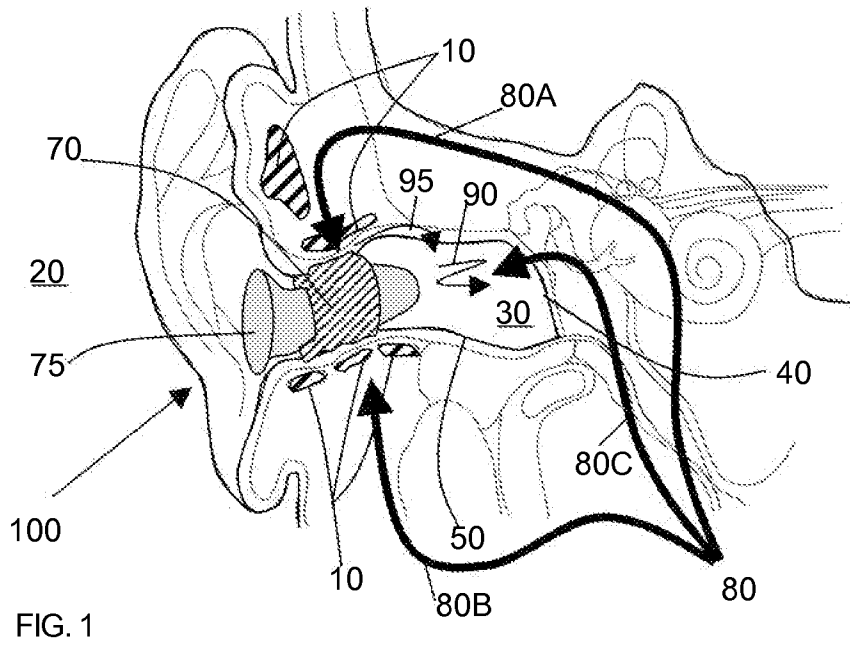

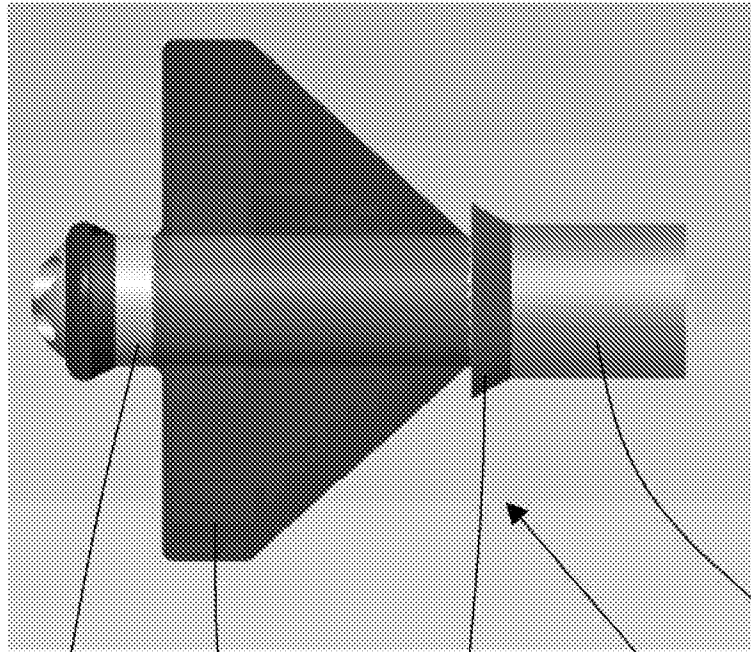

FIG. 3

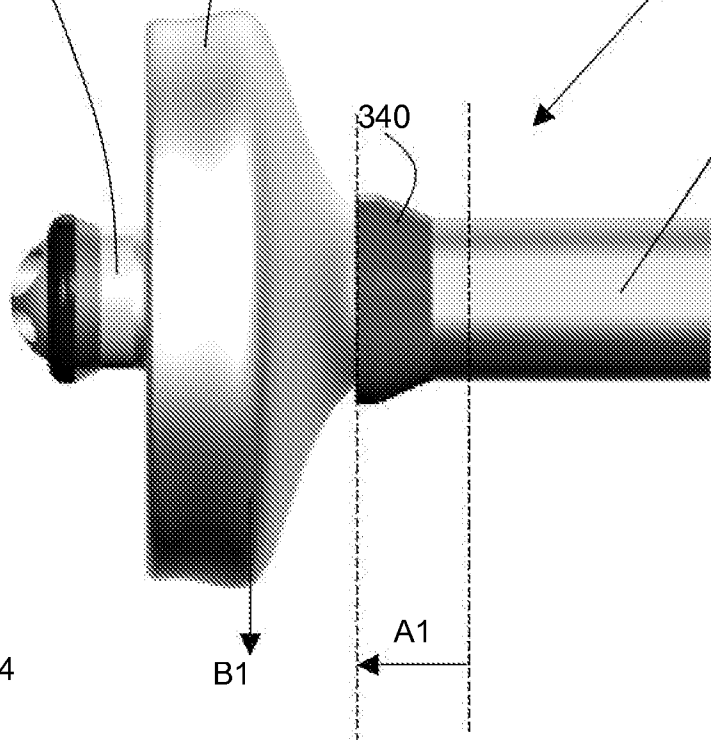
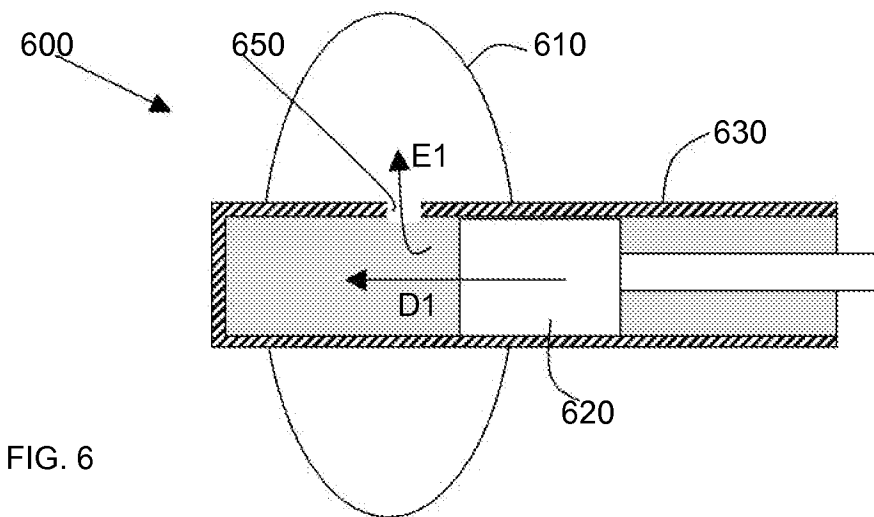
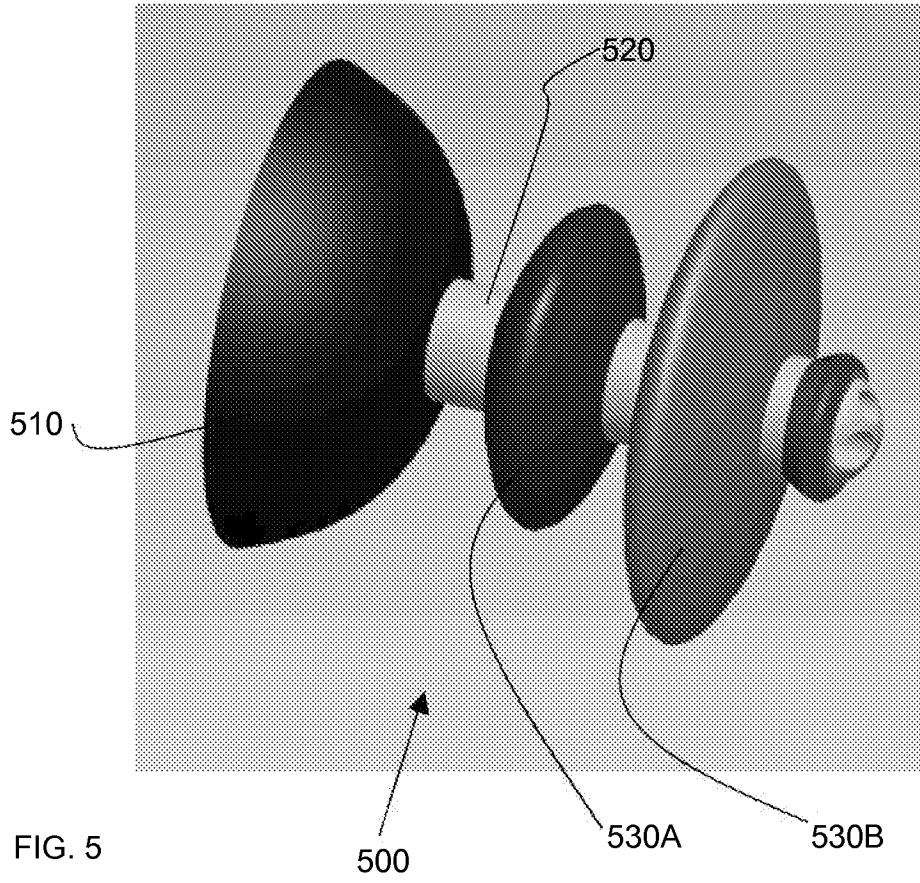

FIG. 4



INTERNATIONAL SEARCH REPORT

International application No.

PCT/US2008/069981

A. CLASSIFICATION OF SUBJECT MATTER

IPC(8) - H04R 25/00 (2008.04)

USPC - 381/380

According to International Patent Classification (IPC) or to both national classification and IPC

B. FIELDS SEARCHED

Minimum documentation searched (classification system followed by classification symbols)

IPC(8) - H04R 25/00 (2008.04)

USPC - 381/380

Documentation searched other than minimum documentation to the extent that such documents are included in the fields searched

Electronic data base consulted during the international search (name of data base and, where practicable, search terms used)

MicroPatent, Google Advanced Patent Search

C. DOCUMENTS CONSIDERED TO BE RELEVANT

Category*	Citation of document, with indication, where appropriate, of the relevant passages	Relevant to claim No.
X	US 2007/0116319 A1 (HAGBERG) 24 May 2007 (24.05.2007) entire document	1
--		--
Y		2-12
Y	US 2005/0058313 A1 (VICTORIAN et al) 17 March 2005 (17.03.2005) entire document	2-10
Y	US 3,602,654 A (VICTOREEN) 31 August 1971 (31.08.1971) entire document	11,12

Further documents are listed in the continuation of Box C.

* Special categories of cited documents:

"A" document defining the general state of the art which is not considered to be of particular relevance

"E" earlier application or patent but published on or after the international filing date

"L" document which may throw doubts on priority claim(s) or which is cited to establish the publication date of another citation or other special reason (as specified)

"O" document referring to an oral disclosure, use, exhibition or other means

"P" document published prior to the international filing date but later than the priority date claimed

"T" later document published after the international filing date or priority date and not in conflict with the application but cited to understand the principle or theory underlying the invention

"X" document of particular relevance; the claimed invention cannot be considered novel or cannot be considered to involve an inventive step when the document is taken alone

"Y" document of particular relevance; the claimed invention cannot be considered to involve an inventive step when the document is combined with one or more other such documents, such combination being obvious to a person skilled in the art

"&" document member of the same patent family

Date of the actual completion of the international search

16 September 2008

Date of mailing of the international search report

22 SEP 2008

Name and mailing address of the ISA/US

Mail Stop PCT, Attn: ISA/US, Commissioner for Patents

P.O. Box 1450, Alexandria, Virginia 22313-1450

Facsimile No. 571-273-3201

Authorized officer:

Blaine R. Copenheaver

PCT Helpdesk: 571-272-4300

PCT OSP: 571-272-7774