

(21) Application No 8107506  
 (22) Date of filing  
 10 Mar 1981  
 (30) Priority data  
 (31) 80/08211  
 80/37231  
 (32) 11 Mar 1980  
 20 Nov 1980  
 (33) United Kingdom (GB)  
 (43) Application published  
 23 Sep 1981  
 (51) INT CL<sup>3</sup> F16L 19/08  
 (52) Domestic classification  
 F2G 22A  
 (56) Documents cited  
 GB 1570036  
 GB 1504580  
 GB1287476  
 GB 723400  
 GB 614698  
 (58) Field of search  
 F2G  
 F2B  
 (71) Applicant  
 Hepworth Plastics  
 Limited

Genefax House  
 Tipton Park Road  
 Sheffield  
 S10 3FJ  
 (72) Inventor  
 David Robert Elliot  
 (74) Agents  
 Hulse & Co  
 Cavendish Buildings  
 West Street  
 Sheffield S1 1ZZ

(54) Pipe couplings

(57) Means enabling a plastics pipe (12) to be used with a compression coupling or fitting (8) comprises a sealing member (1 or 1A or 1B) consisting of a deformable outer ring (2 or 14) and an inner elastomeric ring (3 or 16), with the outer ring initially shaped to form an axial cross-section concave towards the axis, and with the inner ring extending inwards at least as far but preferably

erably beyond the projected surface of revolution (4) between the rims (5 or 20) of the outer ring. The inner ring (3) may line the outer ring (2) and have a central lip (13) or lips only extending beyond the surface of revolution (4), or it may be an O-ring (16) housed in a groove (15) in the outer ring (14). A rigid support sleeve may be inserted into the plastics pipe end before insertion into the pipe coupling or fitting.

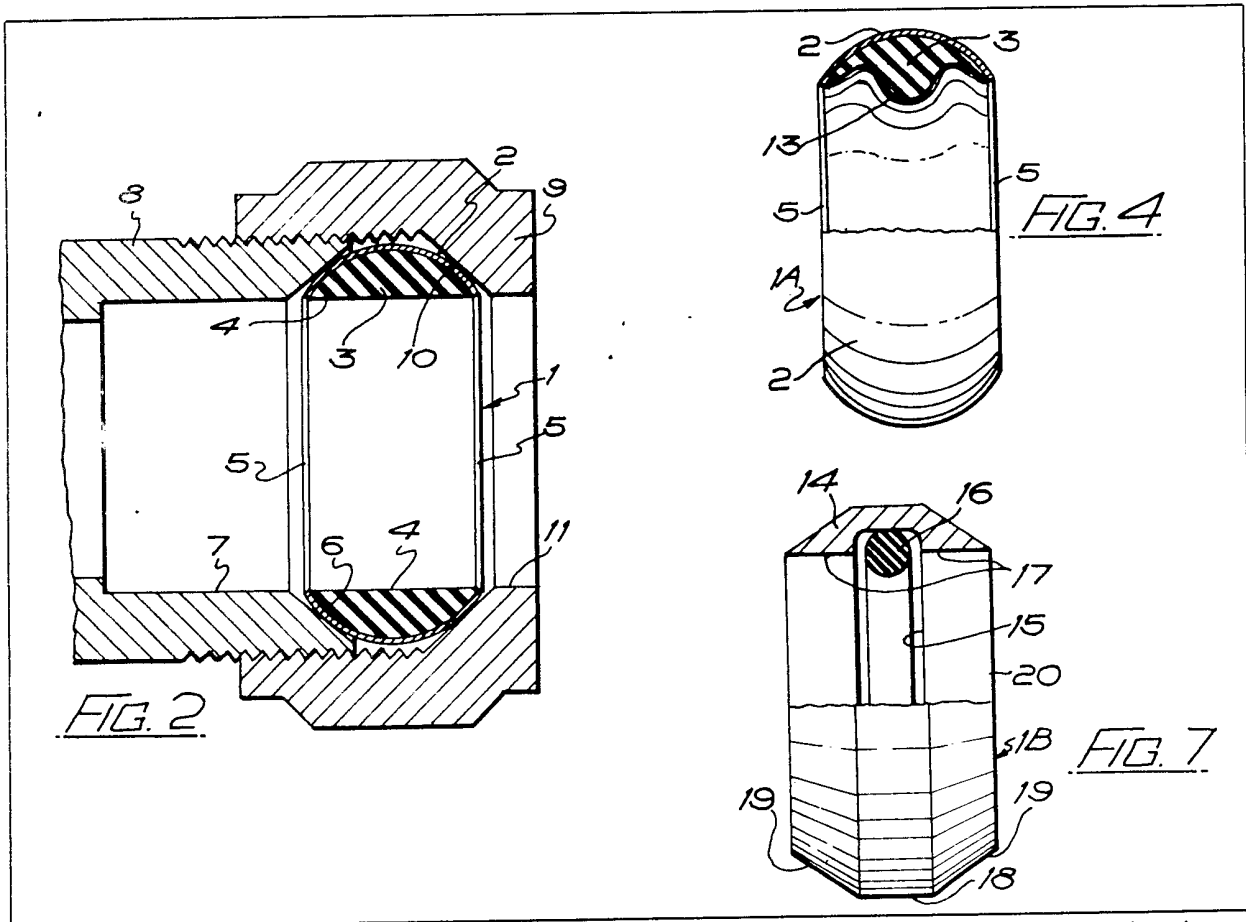

The drawings originally filed were informal and the print here reproduced is taken from a later filed formal copy.

1/3

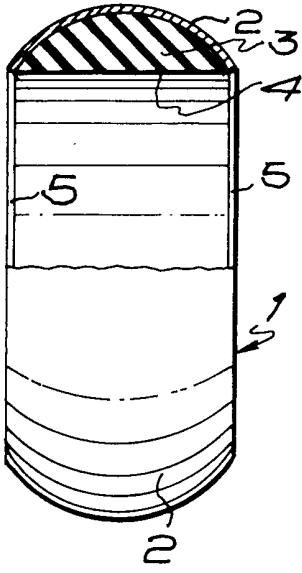

FIG. 1

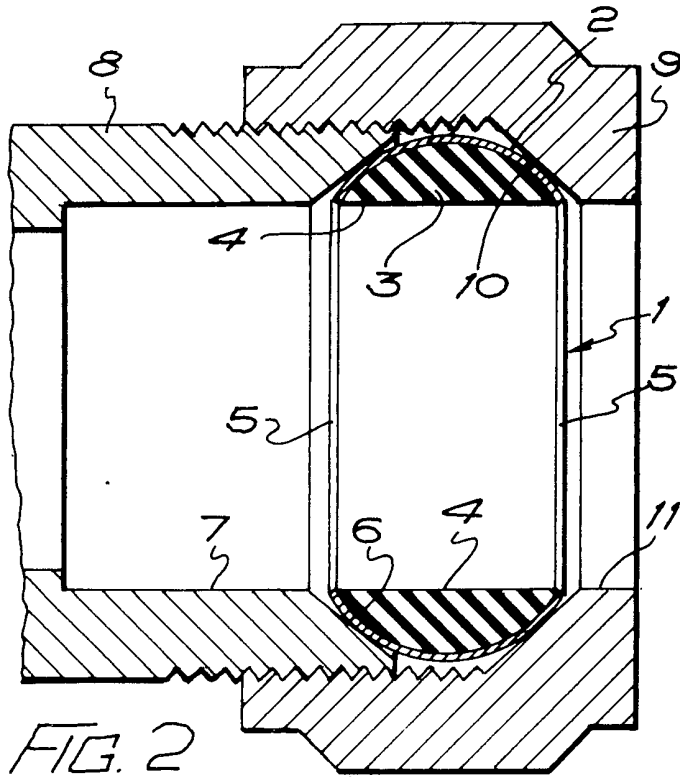

FIG. 2

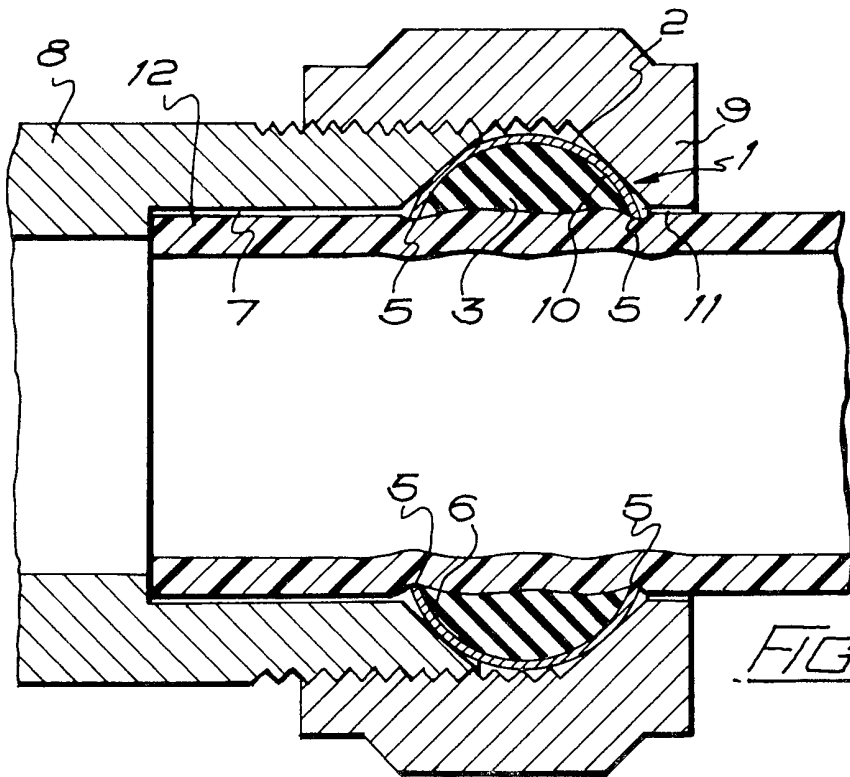
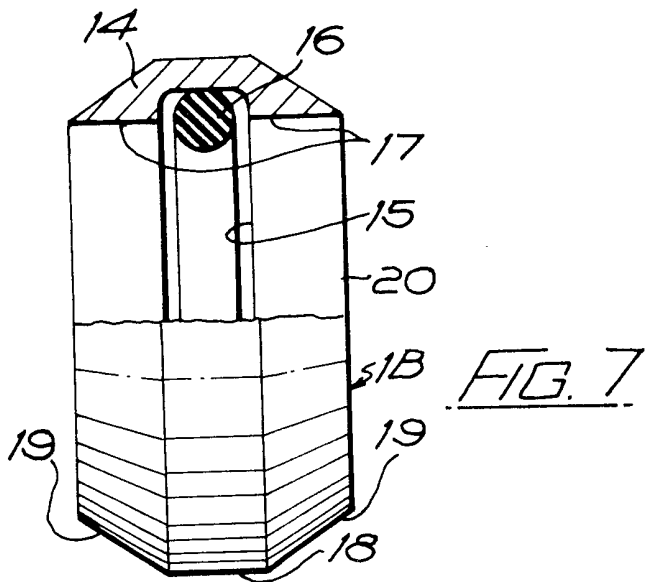
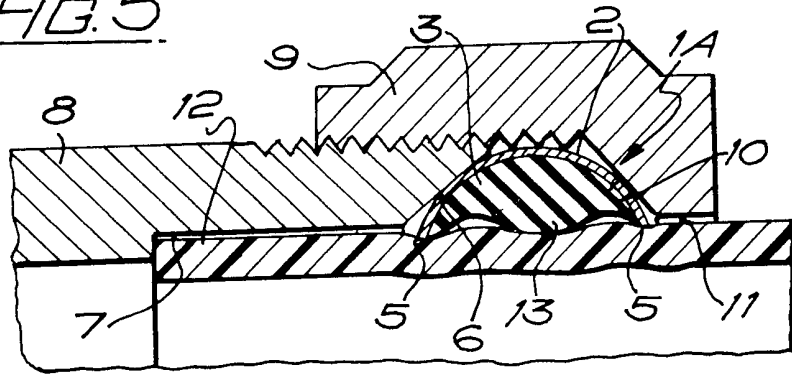
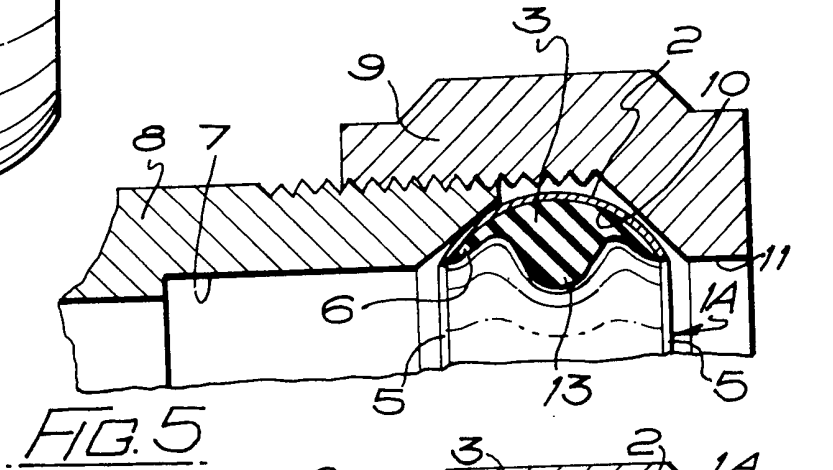
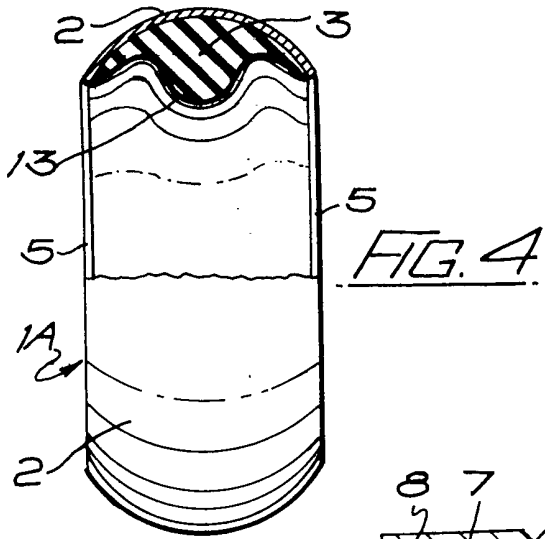

FIG. 3



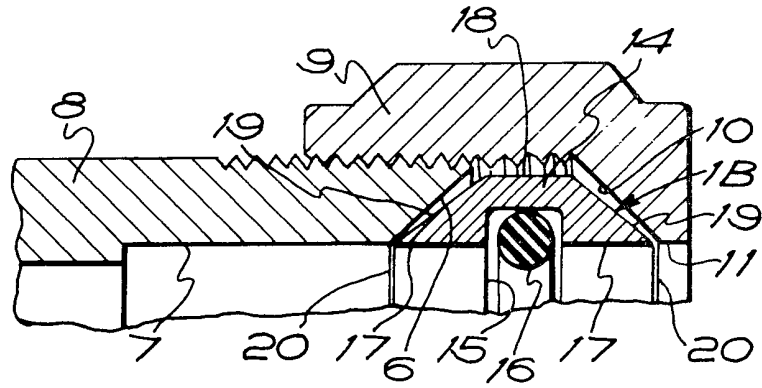

FIG. 8

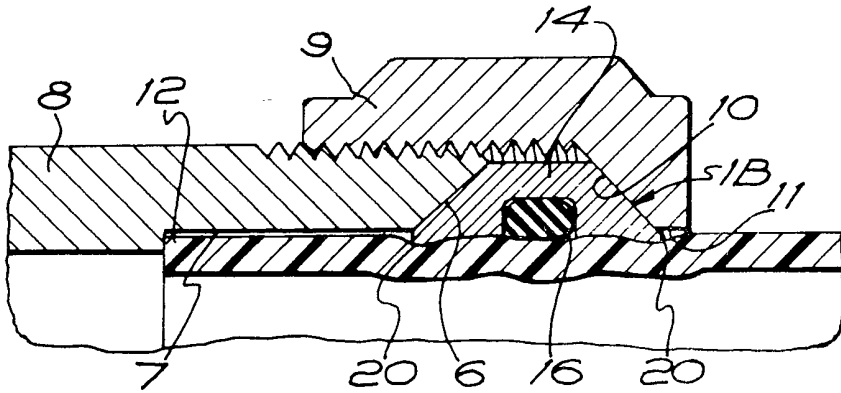

FIG. 9

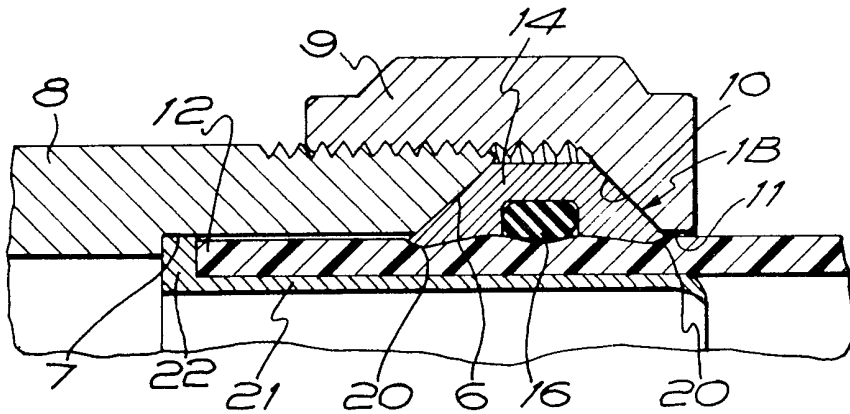

FIG. 10

## SPECIFICATION

**Pipe couplings**

5 This invention relates to pipe couplings and fittings more particularly of the type normally using compression joints in which a tapered ferrule or "olive" on a metal pipe is forced axially by a compression nut into a tapered mouth of a socket in a coupling or fitting, whereby the ferrule or "olive" is compressed radially to grip the pipe and seal both round the pipe and in the socket.

10

15 Plastics pipes are being used increasingly in place of metal ones, but the stress relaxation encountered with plastics pipes when under continuously applied load and fluctuations in temperature make them impractical for long term use with compression joints.

20 The object of the present invention is to provide means enabling plastics pipes to be used with existing couplings and fittings normally using compression joints.

25 According to the present invention, means enabling a plastics pipe to be used with a coupling or fitting normally using a compression joint comprises a sealing member consisting of a deformable outer ring and an inner elastomeric ring component, with the outer ring component initially shaped to form an axial cross-section concave towards the axis of the ring, and with the elastomeric ring component extending radially inwards from the outer ring component at least at its radial mid-plane at least as far as but preferably beyond the projected surface of revolution between the rims of the deformable outer ring component, which rims have an internal diameter not less than the outside diameter of the plastics pipe.

30

35 When the sealing member is interposed between the compression nut and the socket of a compression joint type coupling or fitting (in place of the usual ferrule or "olive") with one rim of the outer ring component entering the tapered mouth of the socket, and a plastics pipe end is inserted through the compression nut, through the sealing member, and into the socket, tightening of the compression nut causes it to push against the rim of the outer ring component remote from the socket (or the outer surface of the outer ring component adjacent the rim remote from the socket), whereby the outer ring component is deformed and the rim within the mouth of the socket is compressed radially to grip the pipe. The elastomeric ring component effects sealing around the plastics pipe by virtue of being distorted radially inwards by the deformation of the outer ring component and/or by virtue of the elastomeric ring component being initially an interference fit on the pipe. The outer surface of the outer ring component adjacent the rim within the mouth of the socket is pressed into intimate contact with the mouth of the socket and therefore effects sealing

65

therewith.

The deformable outer ring component is preferably symmetrical about its radial mid-plane, so that either rim can be inserted into the tapered mouth of the socket in a coupling or fitting.

The deformable outer ring component may be formed of metal, preferably copper or other ductile metal, or of rigid plastics material and the inner elastomeric ring component may fill the space between the inside surface of the metal or rigid plastics ring and the projected surface of revolution between its rims, or the inner elastomeric ring component may line the inside surface of the metal or rigid plastics ring and have a central lip or lips only extending radially inwards beyond the projected surface of revolution between the rims of the metal or rigid plastics ring. The inner elastomeric ring component may be bonded to the inside surface of the metal or rigid plastics ring (e.g., effected when moulding the elastomeric component in situ in the metal or rigid plastics ring) and is preferably formed of peroxide cured ethylene propylene diene methylene or ethylene propylene terpolymer, or silicone rubber.

Alternatively, the deformable outer ring component may be formed of metal or rigid plastics material having an inwardly facing groove forming a housing for the inner elastomeric ring component, which may be a rubber O-ring. The groove is preferably between two cylindrical surfaces, and the outside of the outer ring component is preferably a short central cylindrical surface between the larger diameter ends of a pair of opposed frusto-conical surfaces.

Three embodiments of the invention will now be described, by way of example only, with reference to the accompanying drawings, in which:—

*Figure 1* is a half sectional elevation of one form of sealing member in accordance with the invention;

*Figure 2* is an axial section of a compression joint of a pipe coupling or fitting provided with a sealing member of the form shown in Fig. 1;

*Figure 3* corresponds to Fig 2 but shows a plastics pipe end inserted into the coupling or fitting and gripped and sealed by the sealing member which has been deformed by tightening of the compression nut;

*Figure 4* corresponds to Fig. 1 but shows another form of sealing member in accordance with the invention;

*Figures 5 and 6* correspond to the upper parts of Figs. 2 and 3 respectively but using the form sealing member shown in Fig. 4;

*Figures 7 to 9* correspond to Figs. 4 to 6 respectively but show a further form of sealing member in accordance with the invention; and

*Figure 10* corresponds to Fig. 9 but shows a rigid support sleeve inserted in the plastics

130

pipe end.

Fig. 1 shows a sealing member 1 consisting of a deformable outer ring component 2 and an inner elastomeric ring component 3, with the outer ring component 2 formed of sheet metal, e.g., copper or other ductile metal, with an axial cross-section concave towards the axis of the ring, and with the elastomeric ring component 3 of, for example peroxide cured ethylene propylene diene methylene or ethylene propylene terpolymer, moulded in situ in the metal ring 2 so as to bonded thereto and extending radially inwards as far as the projected surface of revolution 4 between the rims 5 of the sheet metal ring. The deformable outer sheet metal ring component 2 is symmetrical about its radial mid-plane, so that either rim 5 can be inserted into a tapered mouth 6 (Fig. 2) of a socket 7 in a pipe coupling or fitting 8, which has a compression nut 9 with a tapered bearing surface 10. The rims 5 have an internal diameter substantially equal to the internal diameter of the socket 7 and of the entry 11 of the compression nut 9, which internal diameter is slightly greater than the external diameter of a plastics pipe end 12 (Fig. 3) inserted through the compression nut 9, through the sealing member 1, and into the socket 7. Tightening of the compression nut 9 on to the pipe coupling or fitting 8 causes the nut to push against the outer surface of the outer ring component 2 adjacent the rim 5 remote from the socket from the socket 7, whereby the outer ring component is deformed and the rim 5 within the mouth 6 of the socket is compressed radially to grip the pipe 12. The elastomeric ring component 3 effects sealing around the plastics pipe by virtue of being distorted radially inwards by the deformation of the outer ring component 2. The outer surface of the outer ring component adjacent the rim 5 within the mouth 6 of the socket 7 is pressed into intimate contact with the mouth of the socket and therefore effects sealing therewith. Because of the taper of the bearing surface 10 of the compression nut 9, the rim 5 remote from the socket 7 is also compressed radially to grip the pipe 12.

The sealing member 1A of Figs. 4 to 6 is basically similar to the sealing member 1 of Figs. 1 to 3 in that it has the same sheet metal deformable outer ring component 2 and an elastomeric inner ring component 3 moulded therein, but the component 3 lines the inside surface of the component 2 and has a central lip 13 only extending radially inwards beyond the projected surface of revolution between the rims 5 of the metal ring. Thus the elastomeric ring component 3 effects sealing around the plastics pipe 12 by virtue of the lip 13 being initially an interference fit on the pipe.

The sealing member 1B of Figs. 7 to 10 has the deformable outer ring component 14

formed of ductile metal (or rigid plastics material) having an inwardly facing groove 15 forming a housing for the inner elastomeric ring component 16, which is a rubber O-ring.

The groove 15 is between two cylindrical surfaces 17 having an internal diameter substantially the same as the internal diameter of the socket 7 in the pipe coupling or fitting 8 and of the entry 11 of the compression nut 9. The outside of the outer ring component 14 is a short central cylindrical surface 18 between the larger diameter ends of a pair of opposed frusto-conical surfaces 19, the cone angles of which are slightly less than the cone angles of the tapered mouth 6 of the socket 7 and of the bearing surface 10 of the compression nut 9, so that the rims 20 of the outer ring component 14 bite into the inserted plastics pipe end 12.

In Fig. 10 the plastics pipe end 12 is fitted (before insertion into the pipe coupling or fitting 8) with a rigid support sleeve 21 having a locating flange 22.

## 90 CLAIMS

1. Means enabling a plastics pipe to be used with a coupling or fitting normally using a compression joint comprising a sealing member consisting of a deformable outer ring component and an inner elastomeric ring component, with the outer ring component initially shaped to form an axial cross-section concave towards the axis of the ring, and with the elastomeric ring component extending radially inwards from the outer ring component at least at its radial mid-plane at least as far as the projected surface of revolution between the rims of the deformable outer ring component, which rims have an internal diameter not less than the outside diameter of the plastics pipe.

2. A sealing member as in Claim 1, wherein the elastomeric ring component extends radially inwards beyond the projected surface of revolution between the rims of the deformable outer ring component.

3. A sealing member as in Claim 1 or Claim 2, wherein the deformable outer ring component is symmetrical about its radial mid-plane.

4. A sealing member as in any one of Claims 1 to 3, wherein the deformable outer ring component is formed of metal, or of rigid plastics material and the inner elastomeric ring component fills the space between the inside surface of the metal or rigid plastics ring and the projected surface of revolution between its rims.

5. A sealing member as in any one of Claims 1 to 3, wherein the inner elastomeric ring component lines the inside surface of the metal or rigid plastics ring and has a central lip or lips only extending radially inwards beyond the projected surface of revolution between the rim of the metal or rigid plastics

ring.

6. A sealing member as in Claim 4 or Claim 5, wherein the inner elastomeric ring component is bonded to the inside surface of the metal or rigid plastics ring.
7. A sealing member as in any one of Claims 4 to 6, wherein the deformable outer ring component is formed of copper or other ductile metal.
8. A sealing member as in any one of Claims 4 to 7, wherein the inner elastomeric ring is formed of peroxide cured ethylene propylene diene methylene or ethylene propylene terpolymer, or silicone rubber.
9. A sealing member as in any one of Claims 1 to 3, wherein the deformable outer ring component is formed of metal or rigid plastics material having an inwardly facing groove forming a housing for the inner elastomeric ring component.
10. A sealing member as in Claim 9, wherein the inner elastomeric ring component is a rubber O-ring.
11. A sealing member as in Claim 9 or Claim 10, wherein the groove is between two cylindrical surfaces, and the outside of the outer ring component is a short central cylindrical surface between the larger diameter ends of a pair of opposed frusto-conical surfaces.
12. A pipe coupling or fitting provided with a sealing member as in any one of Claims 1 to 11.
13. A sealing member for use in a pipe coupling or fitting and substantially as hereinbefore described with reference to any one of Figs. 1, 4 or 7.
14. A pipe coupling or fitting provided with a sealing member substantially as hereinbefore described with reference to any one of Figs. 2, 5 or 8.
15. A pipe coupling or fitting provided with a sealing member and secured and sealed to a plastics pipe substantially as hereinbefore described with reference to any one of Figs. 3, 6, 9 or 10.