

(19) **DANMARK**

(10) **DK/EP 3494817 T3**



(12) **Oversættelse af  
europæisk patentskrift**

Patent- og  
Varemærkestyrelsen

- 
- (51) Int.Cl.: **A 24 F 40/40 (2020.01)** **A 24 F 40/42 (2020.01)** **A 24 F 40/20 (2020.01)**
- (45) Oversættelsen bekendtgjort den: **2021-04-12**
- (80) Dato for Den Europæiske Patentmyndigheds bekendtgørelse om meddelelse af patentet: **2021-01-13**
- (86) Europæisk ansøgning nr.: **18214917.9**
- (86) Europæisk indleveringsdag: **2006-07-18**
- (87) Den europæiske ansøgnings publiceringsdag: **2019-06-12**
- (30) Prioritet: **2005-07-19 US 70010505 P** **2006-07-11 US 48516806**
- (62) Stamansøgningsnr: **17195788.9**
- (84) Designerede stater: **AT BE BG CH CY CZ DE DK EE ES FI FR GB GR HU IE IS IT LI LT LU LV MC NL PL PT RO SE SI SK TR**
- (73) Patenthaver: **JT International SA, 8, Rue Kazem Radjavi, 1202 Geneva, Schweiz**
- (72) Opfinder: **MONSEES, James, 2019 19th Street, San Francisco, CA 94107, USA**  
**BOWEN, Adam, 360 Elm Street, San Mateo, CA 94401, USA**
- (74) Fuldmægtig i Danmark: **RWS Group, Europa House, Chiltern Park, Chiltern Hill, Chalfont St Peter, Bucks SL9 9FG, Storbritannien**
- (54) Benævnelse: **FREMGANGSMÅDE OG SYSTEM TIL FORDAMPNING AF ET STOF**
- (56) Fremdragne publikationer:  
**DE-A1- 19 854 012**  
**GB-A- 1 213 318**  
**US-A- 720 007**  
**US-A- 1 165 000**  
**US-A- 2 158 928**



# DESCRIPTION

## Field of the Invention

[0001] The present invention is directed to improvements in smoking devices, particularly to smoking articles which employ a formed tobacco cartridge as a source of producing vapor by heat transfer to the cartridge by conduction, convection, and radiation for smoke and flavor. The present invention relates to self-contained vaporization devices, and more particularly, to a low-temperature vaporization device for use of tobacco product. The device is of an elongated main body with a mouthpiece at one end and an attached tubular casing at the other end having a vaporization chamber and a heater. The mouthpiece and the casing form a unitary unit.

## Description of the Related Art

[0002] Smoking devices, such as cigarette holders and pipes are well known in the art for providing flavored vapor from a smokeable substance to a user for therapeutic and smoking pleasure. However, existing devices used have no control of heating and combustion of the tobacco products. The devices tend to produce toxic, tarry and carcinogenic by-products which are harmful and also impart a bitter and burnt taste to a mouth of a user.

[0003] A further problem is that there is no control of contamination of the inhaled vapour mixture with heater exhaust gases, due to inappropriate proportioning and location of the inlets and the exhaust vents. Typically, the exhaust gas is used to directly heat the tobacco, and those gases contain harmful by-products of incomplete combustion.

[0004] In an effort to overcome these deficiencies, there have been numerous attempts to provide a device structure and the substance for producing vapor for smoking which is free from harmful by-product and would provide a cool and soothing vapor for smoking.

[0005] For example, U.S. Patent Application No. 2004/0237974 A1, published on Dec. 02, 2004 for Min discloses a filtering cigarette and cigar holder which removes tar and nicotine from the tobacco smoke.

[0006] U.S. Patent Application No. 2004/0031495 A1, published on Feb. 19, 2004 for Steinberg discloses a vaporization pipe with flame filter which uses a flame to vaporize the smoking substance.

[0007] U.S. Pat. No. 6,164,287, issued Dec. 26, 2000 to White, describes a smoking device which produces smoke from tobacco at low temperatures, without producing harmful by-products.

**[0008]** U.S. Pat. No. 4, 848, 374, issued Jul. 18, 1989 to Chard et al describe a smoking device to vaporize aerosol precursor, an event which precedes condensation to mainstream aerosol precursor by contact with heated surface rather than by hot gases into the mouth of a smoker.

**[0009]** U.S. Pat. No. 4,219,032, issued Aug. 26, 1980 to Tabatznik et al describe a smoking device wherein an extracted smoke is cooled by passing it through a suitable liquid to provide a soothing smoke.

**[0010]** U.S. Pat. No. 4,020,853, issued May 03, 1977 to Nuttall, describes a smoking pipe made of ceramic material such as colored and ornamental porcelain for enhancing the artistic look, and also to provide a circulating air to keep the outer wall of the pipe cool and safe for handling.

**[0011]** U.S. Pat. No. 3,792,704, issued Feb. 19, 1974 to Parker, describes a pipe tobacco smoking system, wherein the pipe and the tobacco capsule are mutually designed to yield a slim-line smoking combination that can be manufactured from relatively low temperature thermo-plastic material.

**[0012]** Other related art may be found in US 720 007 A being directed to a tobacco cartridge, US 2 158 928 A describing a tobacco cartridge and a method of making same and GB 1 213 318 A being directed to a tobacco cartridge for pipe-like smoking device.

#### **SUMMARY OF THE INVENTION**

**[0013]** The present invention is drawn to a novel portable hand-held device as described in the appended claims.

**[0014]** The present invention will become readily apparent upon further review of the following specifications and drawings.

#### **BRIEF DESCRIPTION OF THE DRAWINGS**

**[0015]**

FIG. 1 is a side view of a portable vaporization device, according to a preferred embodiment of the present invention.

FIG. 2 is a sectional view of the same embodiment.

FIG. 3 is a perspective view of a heater, according to the same embodiment.

FIG. 4 is a cutaway view of an alternate embodiment according to the present invention.

FIG. 5 is a sectional detail view of a tobacco cartridge, according to the preferred embodiment.

FIG. 6 is a perspective view of a tobacco cartridge, according to the preferred embodiment.

FIG. 7 is a sectional detail view of a tobacco cartridge, according to an alternate embodiment.

FIG. 8 is a sectional detail view of a tobacco cartridge, according to an alternate embodiment.

## **DETAILED DESCRIPTION OF THE INVENTION**

**[0016]** Referring to FIG. 1 and FIG. 2, the exterior of the device 10 comprises a mouthpiece 11, a tubular case 12, and the base 14 of a butane tank 21. The mouthpiece is removable and creates an airtight seal with the interior of the case. With the mouthpiece removed, a tobacco cartridge (FIG. 5) is introduced to vaporization chamber 15 of a heater 16. The mouthpiece is then reinserted to close the device.

**[0017]** The mouthpiece is made of a high-temperature and food-safe material such as ceramic, glass, or various high-temperature plastics such as PEI resin (brand name Ultem). Design is simplified by use of high temperature materials, but standard plastics or wood, etc., could also be used with the addition of an insulating component that prevents any excessive heat from reaching the user's lips.

**[0018]** To activate the device, the butane tank is pulled axially outward, partially removing it from the case. This starts the flow of butane by opening a master valve 18, and then activating a piezoelectric igniter 13. The tank remains in the partially removed position for the duration of use. While the master valve is open, butane flows through a thermal regulator 17, and into the carburetor 20. Ambient air enters the case through slot 19. A venturi in the carburetor entrains air, causing it to mix with the butane. The mixture then flows into the heater 16.

**[0019]** The lead of the ignitor is positioned in the heater. With the spark of the ignitor (immediately following the start of gas flow) the gas ignites and heat starts conducting throughout the heater. Heat transfers to the cartridge by conduction, convection, and radiation. The cartridge is shaped to fill the chamber, so as to maximize surface contact for thermal conduction.

**[0020]** As the cartridge heats, vapor generates within the cartridge and in the space immediately above it. When a user draws on the device, fresh air enters through air inlet 22, mixes with the vapor, and the mixture is delivered to the user via the inhalation passage 23. In the preferred embodiment, the air inlet or inlets are directed downward, so as to improve the extraction of vapor from the cartridge. They could also be directed along a diagonal through the mouthpiece, or laterally through the case itself, above the cartridge.

**[0021]** FIG. 3 depicts a detailed view of the heater 16. The heater comprises a thermally conductive shell 26 and catalyst 27. The shell could be comprised of one material, or a combination of materials welded or pressed together. The catalyst could be platinum- or palladium-impregnated metal or glass, or other suitable material known to those skilled in the art. The catalyst provides for efficient flame-less combustion of the butane. The vent 28 of the heater is positioned such that it is visible through the slot 29 of the body as shown in FIG 1. This allows the user to see the catalyst which, when heated, can glow red to indicate that the device has been activated.

**[0022]** Referring again to FIG. 3, adjacent to the heater and in intimate thermal contact is the thermal regulator 17. As the temperature of the heater increases, so does that of the regulator. The regulator is designed to restrict the flow of butane as the temperature increases, thus creating a feedback loop. In the preferred embodiment, the regulator consists of a bimetallic strip 60 and silicone tubing 61 which is the conduit of the butane. The two are arranged such that as the bimetallic strip heats up, it curls to pinch the silicone tube and thereby restrict the flow of butane. The reduced flow of butane results in less heat generated. The heater subsequently cools down, and so does the regulator, allowing more butane to flow again. The overall result is that a stable operating temperature is established in the heater. Such a system can be readily tuned to achieve an operating temperature that varies by less than +/-2.8 degrees Celsius.

**[0023]** The regulator further comprises a moveable backplate 62 which allows adjustability of the operating temperature by adjusting the temperature at which the bimetallic actuator closes the tube valve. This is to be performed once at manufacture, to calibrate the device. In alternate embodiments, a control means could be used to allow the target temperature of the device changed during operation.

**[0024]** In the preferred embodiment, the regulator comprises in part a bi-metallic strip and silicone tubing valve. In alternate embodiments, the regulator could be comprised of other materials and configurations, as described later.

**[0025]** For the purposes of vaporizing most botanicals in this device, the desired operating temperature is below 204,4 °C; preferably below 176,7 °C.

**[0026]** In the preferred embodiment, the air inlet diameter is sized such that inhalation is somewhat inhibited. This allows time for ambient air entering the chamber to heat up and not affect operating temperature considerably. It also increases velocity of the entering air, which improves circulation and mixing in the vaporization chamber. It also creates a partial vacuum, lowering the vapor point temperature for material contained in the vaporization chamber. The reduction in draw rate can also serve to give the impression of drawing on a cigarette or pipe. Both the fresh air inlet and inhalation passage can be adjusted to provide appropriate draw rate for the operating temperature of the device, and the perception intended for the user.

**[0027]** Once the cartridge is consumed, the device is turned off by pushing the tank back into

the case, closing the master valve. The spent tobacco cartridge is removed by opening the device and turning the body over. In the preferred embodiment, the cartridge simply falls out. In alternate embodiments, a mechanism could be used to quickly and easily remove the cartridge. This mechanism could include, but does not require, the use of a pin or slide part to eject the cartridge as another part of the device is moved or removed. The removal mechanism could also involve introduction of a foreign object.

**[0028]** In an alternate embodiment, the mouthpiece is permanently attached to the body. In that case, the vaporization chamber could be accessed by operating a sliding or hinged door, or similar means, built into the device.

**[0029]** The heater of the device is fitted into the case with an insulator 24. The insulator could be made of PE1 (brand name Ultem), ceramic, or other insulating material. The insulator serves to minimize thermal transfer from the heater to the case, while creating an air-tight seal. The seal prevents exhaust gases produced by the heater from entering the vaporization chamber. Exhaust gases are instead vented out the case slots. Since the air inlet is distant from the slots, there is substantially no contamination of the inhaled vapor mixture by heater exhaust gases.

**[0030]** In an alternate embodiment, the insulator could be a partially hollow shell, containing a sealed vacuum. In another embodiment, the heater might be sealed directly to the case by braising in a vacuum furnace, so as to create a vacuum between the two and obviate need for an insulator component.

**[0031]** In the preferred embodiment, the tank is made of a translucent material. This allows the user to determine the level of fuel remaining by looking at the base of the tank.

**[0032]** In the preferred embodiment, the case is made of a material that is either a good thermal conductor (such as aluminum), or a poor one (such as ceramics). In both cases, the effect is that the body remains cool enough to touch over a large portion of its surface.

**[0033]** In the preferred embodiment, a bimetallic actuator is used in the regulator. In alternate embodiments, a shape memory alloy actuator such nickel-titanium alloys ("Nitinol") could be used. Alternatively, a paraffin-filled component that expands and contracts to modulate butane flow could be employed. Alternatively, a system could be employed to measure the current temperature, e.g., with a thermocouple sensor and compare it to a prescribed temperature, e.g., with a micro-controller, and by controlling an electromechanical valve, e.g., servo or solenoid valve. In an embodiment with user-selected temperature, as described above, the selected temperature could be used as an input to this system.

**[0034]** In the preferred embodiment, a thermal regulator is used. In an alternate embodiment, the device is constructed without an active regulating element. This could result in reduced complexity and in lowering the overall cost of the device. In this case, the flow of butane is set at a low level. In use, the temperature inside the chamber increases until an equilibrium point

where additional heat introduced equals the heat lost to the environment. Heat is lost by conduction through the body of the device, and with the vapor delivered to the user. This equilibrium point determines the operating temperature of the device. By changing the butane flow rate, size and material of the burner, and other factors, the system can be calibrated to provide a fairly stable desired operating temperature.

**[0035]** The principal advantage of the preferred bimetallic regulator feedback loop methods over the equilibrium method is that the operating temperature is not dependent on environmental factors such as ambient temperature and wind.

**[0036]** In the preferred embodiment, a piezo-electric ignitor is used. Other ignitors could be used, such as, a flint starter or battery-powered resistive coil.

**[0037]** In the preferred embodiment, the butane tank is meant to be refillable, and has a port 25 for that purpose. As an alternate embodiment, the tank might be disposable once its fuel is exhausted. A release mechanism such as a pin or cam would be employed allowing the user to quickly remove the depleted tank and replace it with a full one. The replaceable tank might include additional parts of the device including, but not limited to, the ignitor and heater. Butane is the preferred fuel source, but could be replaced by other liquid fuels, such as ethanol.

**[0038]** In alternate embodiments of the present invention, various means of feedback could be used to indicate the following states or metrics of the device: 1) the device is on, 2) the current temperature of the vaporization chamber, 3) the chamber is below a prescribed operating temperature, 4) the chamber has reached a prescribed operating temperature and vapor is ready for consumption, and 5) the chamber has exceeded a prescribed operating temperature.

**[0039]** The means of the feedback includes both physical and electronic implementations. Possibilities include thermochromatic paint, light-emitting diodes and liquid crystal display. The sensing and control means for electronic feedback could be implemented by use of thermocouple and micro-controller, as is known to those skilled in the art.

**[0040]** Active elements contained in botanicals vaporize at different temperatures. In the preferred embodiment, the device is calibrated to establish a single stable temperature, intended for vaporizing solely tobacco or solely chamomile, for example. In alternate embodiments, a control means would be used to select a variety of temperature settings. The user would choose which setting based on the type of cartridge used. The control means could effect a desired temperature mechanically, such as by changing flow rate of the valve, or electronically, such as by electromechanical valve and micro-controller intermediary.

**[0041]** Butane was found to be the most energy-dense and practical fuel source. In alternate embodiments of the invention, the butane heating system is replaced by a battery-powered electric heater or other compact heat source.

**[0042]** FIG. 4 depicts a cutaway view of an alternate embodiment which more closely



resembles a traditional pipe form. In this embodiment the device retains all of the critical elements from the preferred embodiment. The user inserts a tobacco cartridge 40, under a sliding top piece 41, where the cartridge mates with the heater 42. Fuel held in the tank 43 is released by turning dial 44 to open master valve 45. The fuel travels through the regulator 51, and then through the carburetor 46 where it draws in air through the intake port 47 and catalyzes in a manner similar to that of the preferred embodiment. As the cartridge 40 reaches its operating temperature the user places the mouthpiece 48 in their mouth and draws air in through the inhalation intake port 49 and through the vapor passage 50 where it is pre-cooled.

**[0043]** FIG. 5 depicts a sectional view of the tobacco cartridge 30. In the preferred embodiment, it consists of tobacco material 31, enclosed in a wrapper 32, with perforations 33, and aeration wells 34. The wrapped cartridge allows for the easy insertion and disposal of tobacco material without creating a mess, while the perforations allow the formed vapor to be released. When the cartridge is used up it can be easily disposed of in its entirety.

**[0044]** Here, tobacco or tobacco material is defined as any combination of natural and synthetic material that can be vaporized for pleasure or medicinal use. As an example, one test cartridge was prepared as embodiment of the present invention using flue-cured tobacco, glycerin, and flavorings. Those skilled in the art of tobacco product manufacture are familiar with these and other ingredients used for cigarettes, cigars, and the like. The test cartridge was produced by chopping tobacco into fine pieces (less than 3mm diameter, preferably less than 2mm), adding the other ingredients, and mixing until even consistency was achieved.

**[0045]** In the preferred embodiment, the cartridge is primarily cylindrical. In other embodiments, the form could be modified for various reasons. As an example, the walls of the cartridge might be drafted for easier insertion into the vaporization chamber. Or, the bottom of the cartridge might possess receptacles, which when combined with complimentary features on the surface cavity of the vaporization chamber would allow for more surface contact and hence improved thermal conduction.

**[0046]** Any material could be used for the wrapper, provided that when heated to the operating temperature, it does not produce significant amounts of harmful gases. Aluminum foil and parchment paper are two examples. With papers, the cartridge would be manufactured in a folded-cup design, similar to that shown in FIG. 6. With films or metal foils, the wrapper could be pressed or blow-molded to the appropriate shape.

**[0047]** During manufacture of the preferred embodiment, the cartridge is enclosed on all sides, and perforated on the top so that vapors can emanate upwards. In the perforation step, or in an additional step, the optional aeration wells would be created.

**[0048]** In an alternate embodiment, the cartridge might be wrapped on all sides but leaving the top exposed, as shown in FIG. 7. This is possible since the purpose of the wrapper is primarily to prevent tobacco material from touching the sides and bottom of the vaporization chamber.

**[0049]** In another embodiment, the material for the top of the cartridge might be vapor-permeable, such that perforations are not necessary.

**[0050]** In another embodiment, the cartridge as purchased by the user has no openings, but is punctured prior to insertion into the device, or upon introduction to the vaporization device. The latter could be achieved by adding a hollow puncturing means to the mouthpiece part of the device. For example, the inhalation passage of the mouthpiece could be extended by a hollow tube. When the mouthpiece is reinserted to close the device, it pierces the cartridge previously introduced, and allows a path for vapor to exit to the user.

**[0051]** In the preferred embodiment, the tobacco material is a homogenous mixture. In another embodiment, there might be two layers, as shown in FIG. 8. The moist layer 35 has higher content of vapor-forming material than the dry layer 36, which consists of dry tobacco or other material acting as a filter. The dry layer serves to prevent any liquid from bubbling up and out of the cartridge during heating.

**[0052]** In another embodiment of the cartridge, a lower compartment might consist entirely of a vapor-forming medium, such as glycerine. An upper region would consist of the tobacco material to be vaporized, and the two would be separated by a material that only allows the medium to pass in a vapor or gaseous phase. Gore-tex (brand name) is one such material. In use, vapor generated in the lower region would pass through the semi-permeable membrane, volatilize the active components of the tobacco, and a mix of the two would be delivered to the user upon inhalation.

**[0053]** In another embodiment, the consistency of the tobacco material is such that the wrapper is not necessary. This is possible if at least the outer surface of the cartridge is dry and cohesive enough to not leave deposits inside the device. Such a cartridge can be made by forming tobacco material in a mold. If the resulting surface is excessively moist, it can be dried by heating the cartridge in an oven.

**[0054]** It is to be understood that the present invention is not limited to the embodiments described above, but encompasses any and all embodiments within the scope of the following claims.

## **REFERENCES CITED IN THE DESCRIPTION**

This list of references cited by the applicant is for the reader's convenience only. It does not form part of the European patent document. Even though great care has been taken in compiling the references, errors or omissions cannot be excluded and the EPO disclaims all liability in this regard.

**Patent documents cited in the description**

- US20040237974A1 [0005]
- US20040031495A1 [0006]
- US6164287A [0007]
- US4848374A [0008]
- US4219032A [0009]
- US4020853A [0010]
- US3792704A [0011]
- US720007A [0012]
- US2158928A [0012]
- GB1213318A [0012]

## Patentkrav

1. Bærbar, håndholdt anordning (10), som omfatter et fordampningskammer (15), der har et hulrum disponeret deri og  
5 en patron med et rygbart materiale (30), hvor anordningen er konfigureret til at fordampe et rygbart materiale i hulrummet i fordampningskammeret, idet patronen omfatter det rygbare materiale; og en bund, der omfatter koblingssteder;  
10 hvilke koblingssteder kan kombineres med komplementære træk på en overflade af hulrummet.
2. Bærbar, håndholdt anordning ifølge krav 1, som yderligere omfatter en væg på patronen, hvor væggen er drafted.  
15
3. Bærbar, håndholdt anordning ifølge krav 1, hvor patronen er cylindrisk.
4. Bærbar, håndholdt anordning ifølge et hvilket som helst  
20 af kravene 1 til 3, hvor det rygbare materiale omfatter tobak.
5. Bærbar, håndholdt anordning ifølge krav 4, hvor tobakken omfatter mindst det ene af glycerin og et smagsstof.
- 25 6. Bærbar, håndholdt anordning ifølge et hvilket som helst af kravene 4 og 5, hvor tobakken er skåret tobak, der er skåret i fine stykker på mindre end 3 mm i diameter.
- 30 7. Bærbar, håndholdt anordning ifølge et hvilket som helst af kravene 1 til 4, hvor en driftstemperatur er under 204 °C, fortrinsvis under 177 °C, til fordampning af plantematerialer.

DRAWINGS

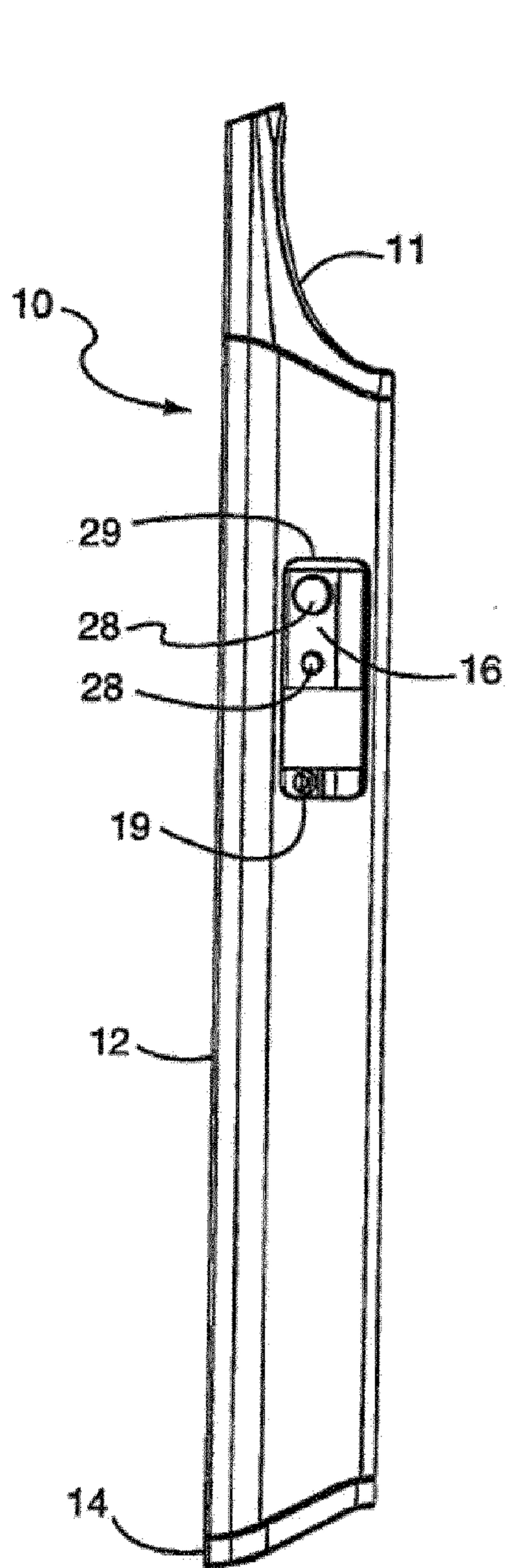

FIG. 1

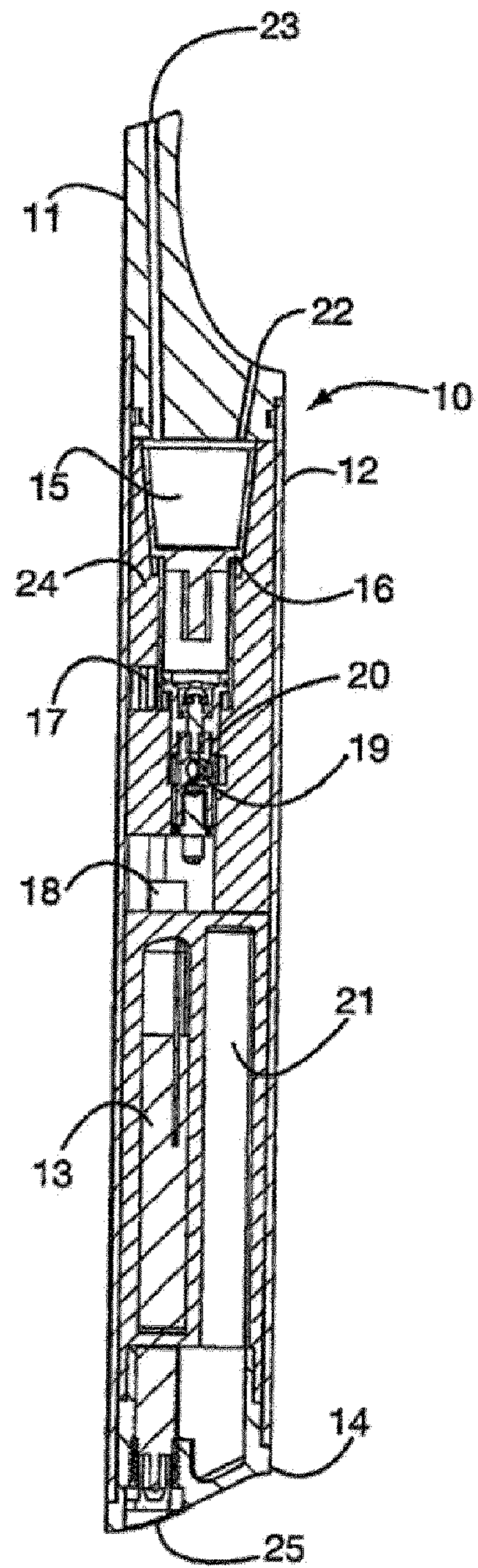

FIG. 2

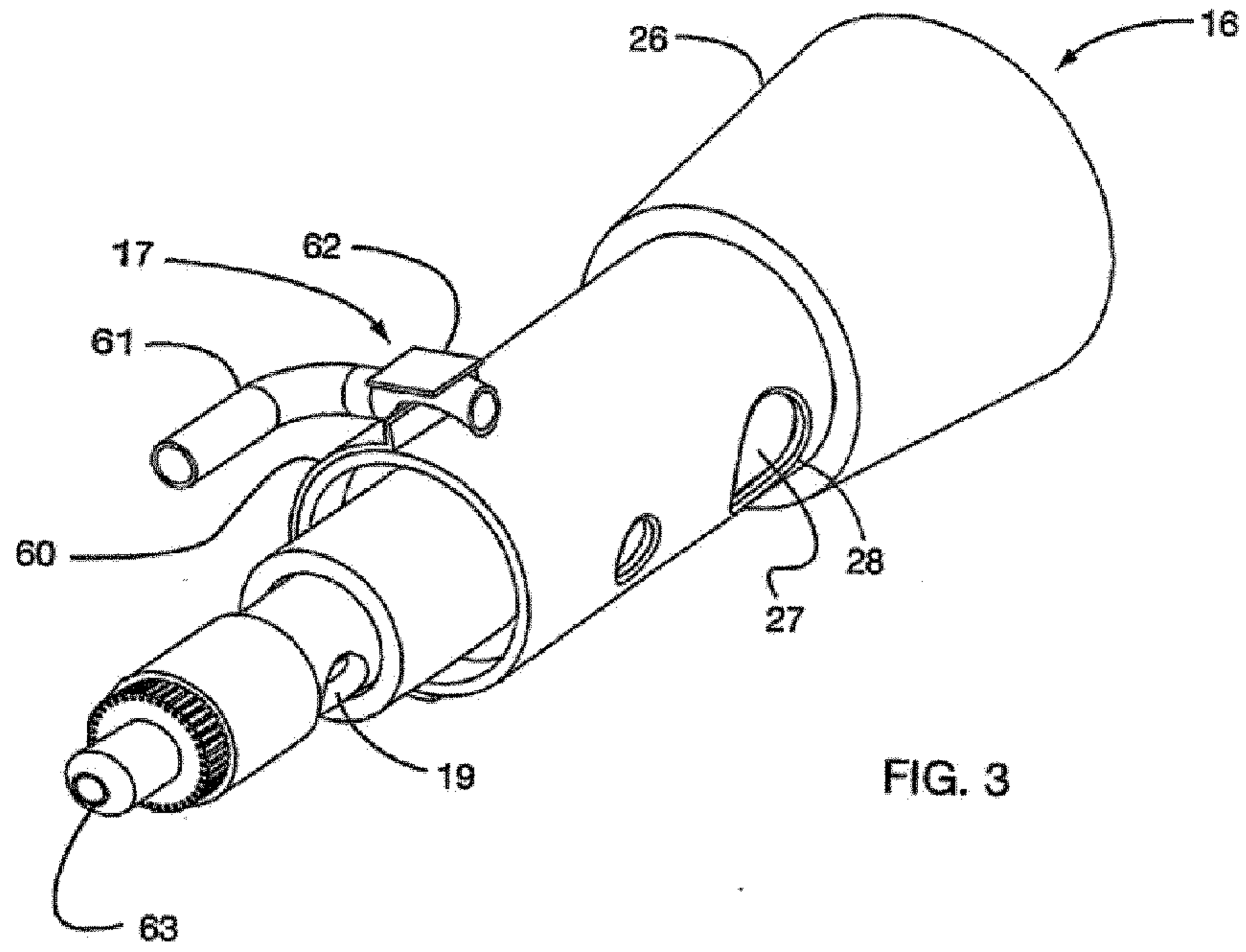

FIG. 3

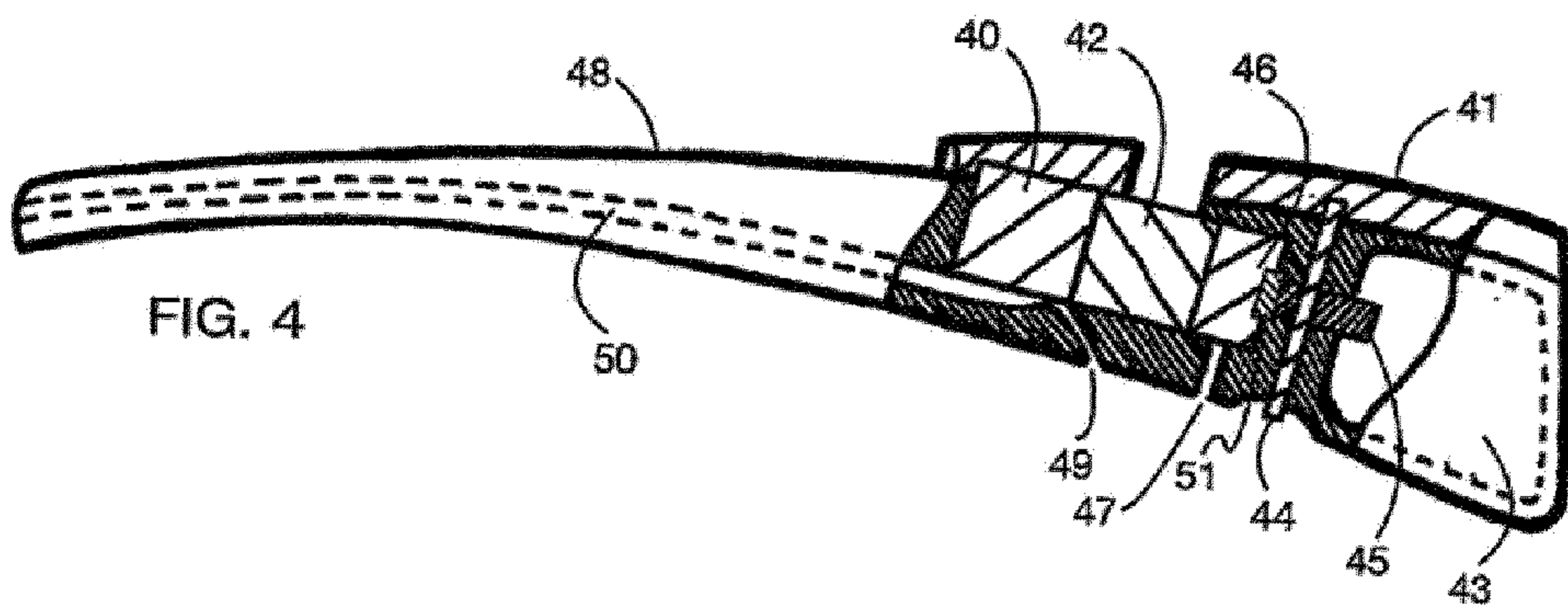

FIG. 4

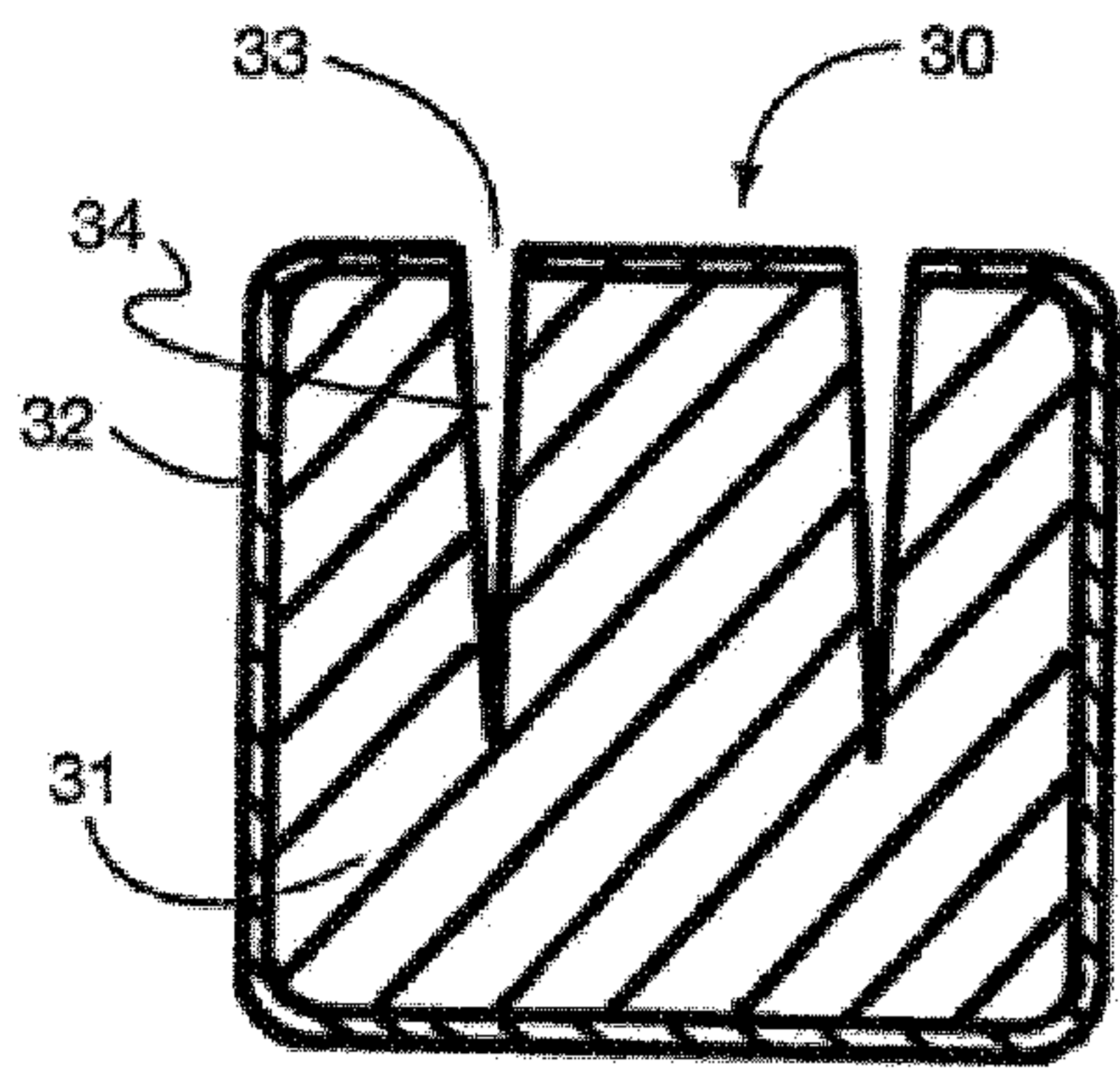

FIG. 5

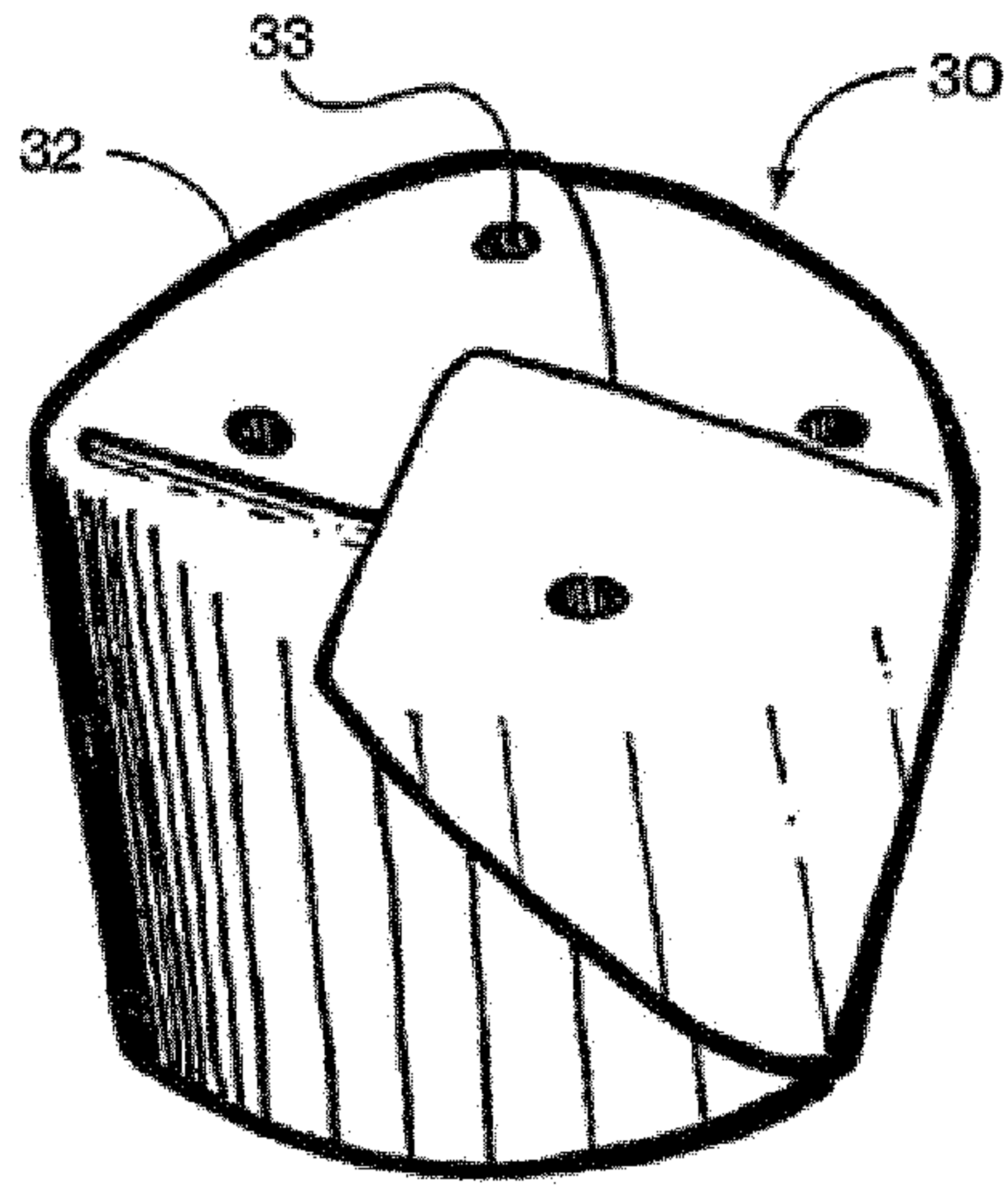

FIG. 6

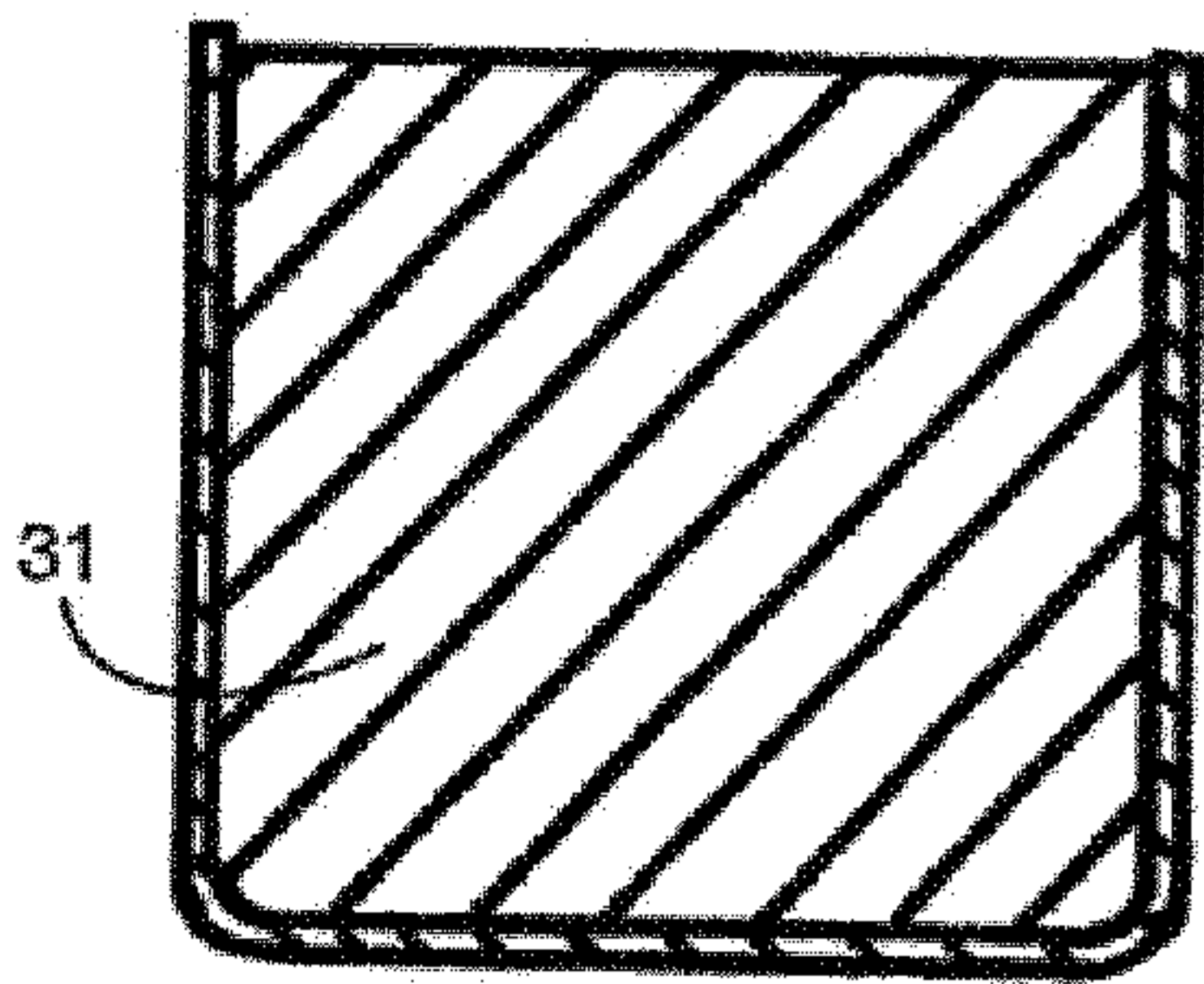

FIG. 7

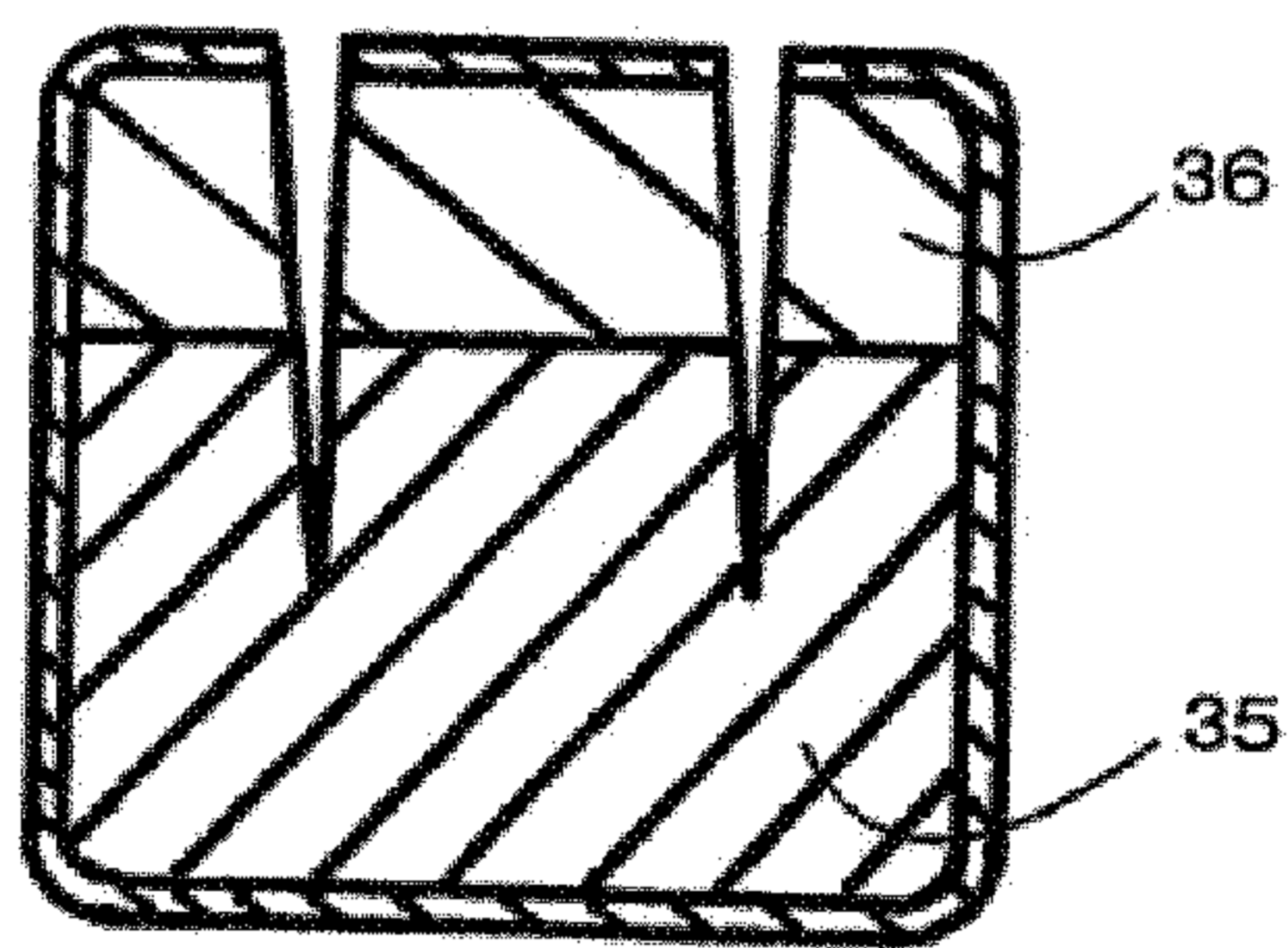

FIG. 8