

(21) Application No: 1301481.6

(22) Date of Filing: 28.01.2013

(71) Applicant(s):
Verplas Limited
(Incorporated in the United Kingdom)
Unit Seven, Verwood Industrial Estate, Blackhill,
VERWOOD, Dorset, BH31 6HA, United Kingdom

(72) Inventor(s):
Kenneth Armstrong

(74) Agent and/or Address for Service:
Venner Shipley LLP
200 Aldersgate, LONDON, EC1A 4HD,
United Kingdom

(51) INT CL:
F24F 13/02 (2006.01)

(56) Documents Cited:
DE 010019330 A1 **SU 001670301 A1**
KR 100877141 B

(58) Field of Search:
INT CL **F24F**
Other: **Online: WPI, EPODOC**

(54) Title of the Invention: **Ventilation duct coupling**
Abstract Title: **Ventilation duct coupling**

(57) A coupling for interconnecting ventilation ductwork elements together. The coupling comprises an outer wall 5 defining a socket 2, 3 slideably receiving and supporting an end of a ductwork element therein and releasably connect said ductwork element to the coupling. The socket includes a slot 8, 9 and a seal member 12 to seal against the outer wall, the seal configured to resiliently deform and engage the ductwork element as the ductwork element is received in said socket to form a substantially airtight seal between the coupling and the ductwork element. The seal may comprise a primary (14, fig 4) and secondary (15) seal portion. The primary seal may be a flap and the secondary seal may be a domed or triangular shape. A retaining ring 13 may locate the seal in a seat 11. The ring may be formed of a resilient material snap-fit over an end of the socket. The inner wall may have a chamfered edge 6a to guide an element into the slot. A plurality of elements may be coupled together with a plurality of couplings. The coupling may be integral with the ductwork and may comprise bends or t-pieces.

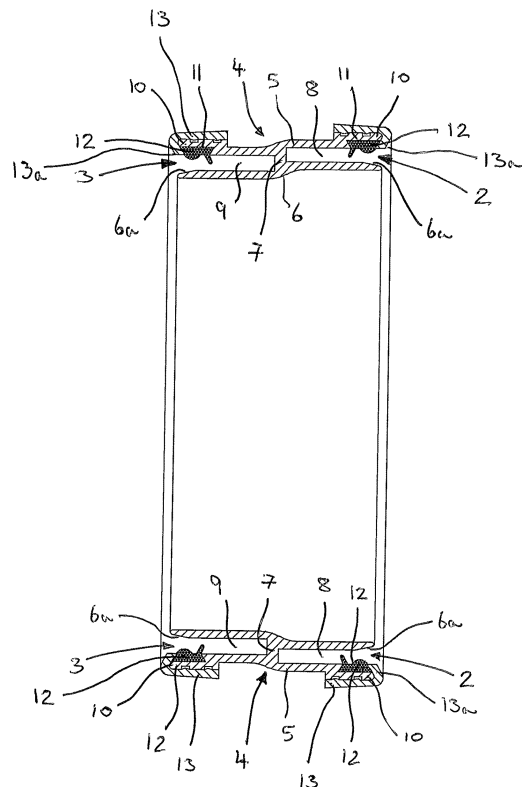

FIGURE 2

23 04 14

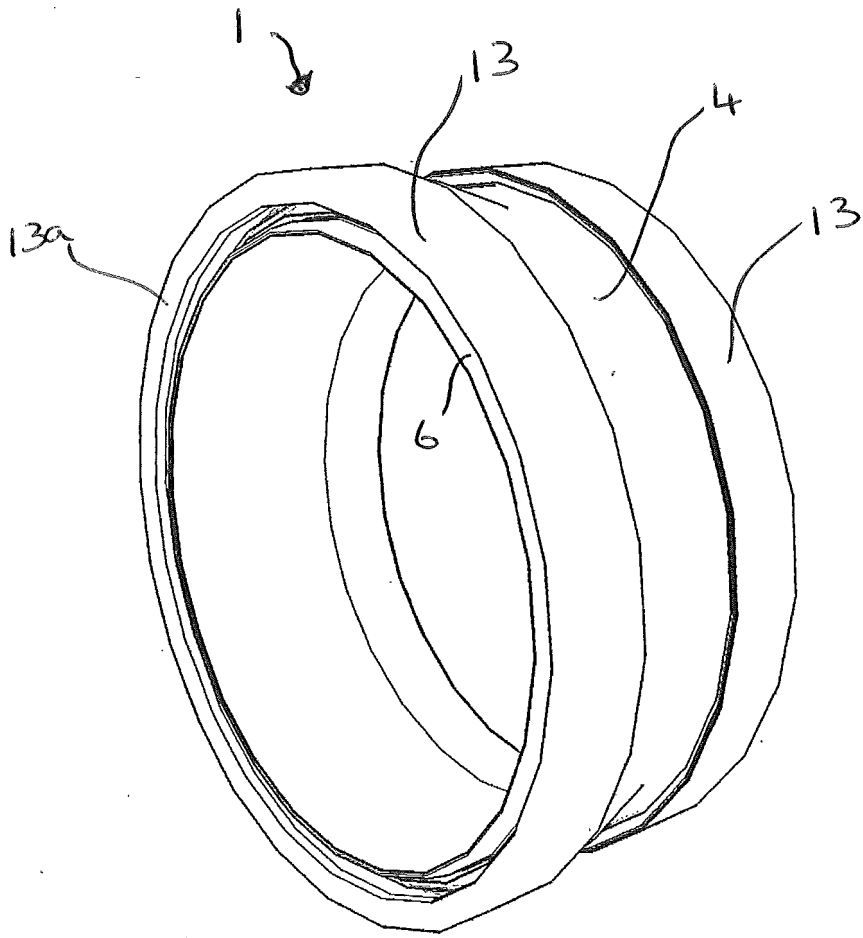

FIGURE 1

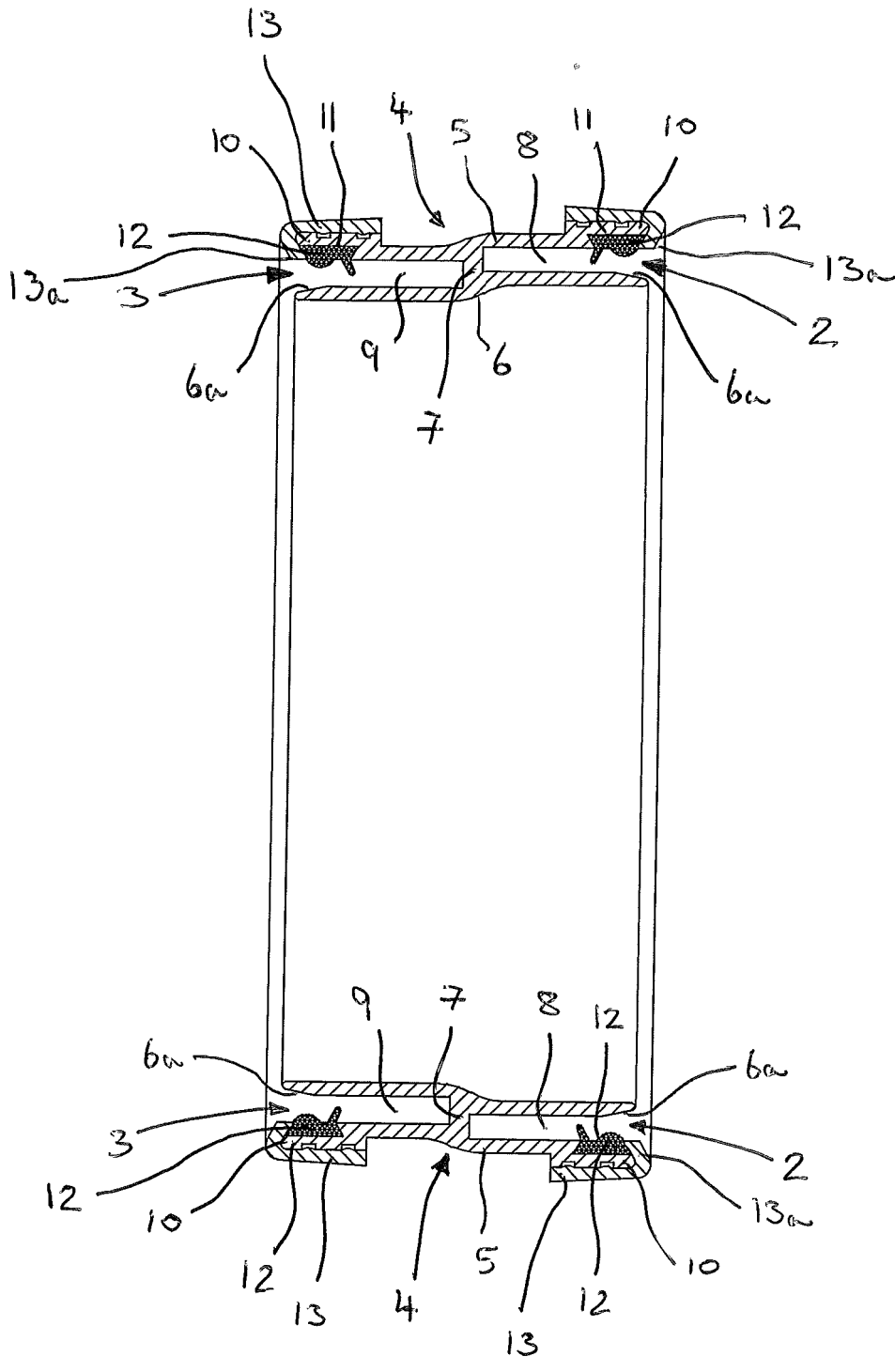

FIGURE 2

23 04 14

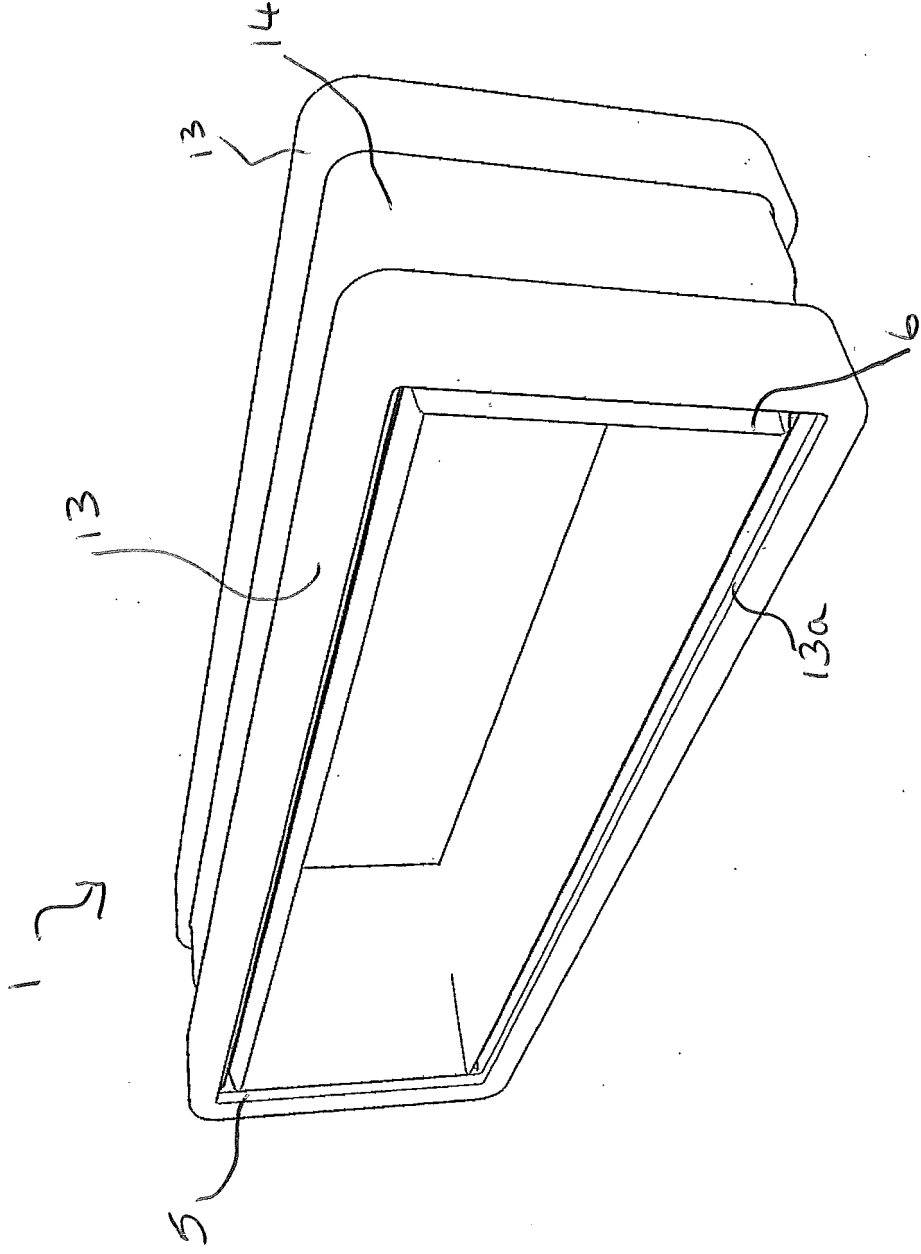

FIGURE 3

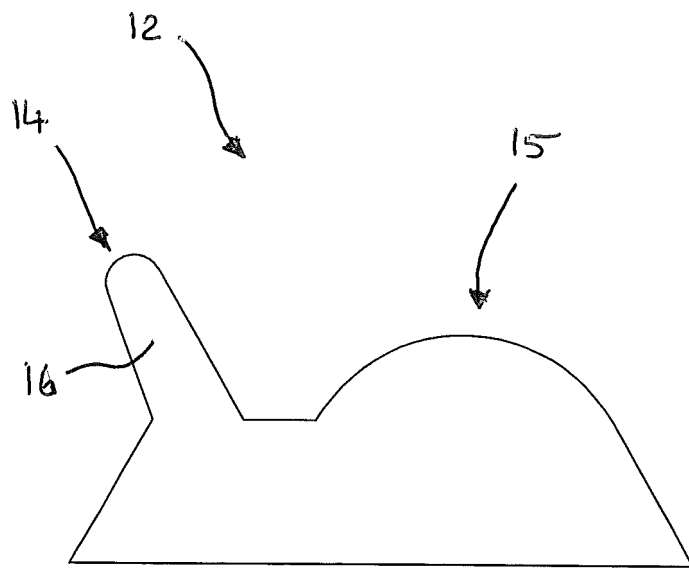

FIGURE 4

23 04 14

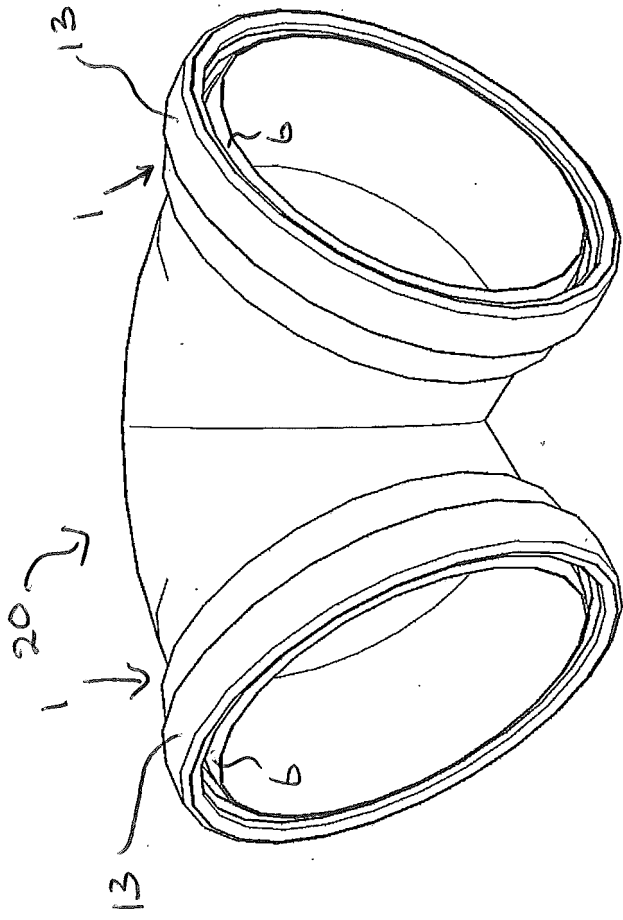

FIGURE 5

Ventilation Duct Coupling

Description

The present invention relates to a coupling for joining lengths of ventilation ducting or
5 ventilation ductwork components or accessories together.

A ventilation ductwork system is used to circulate warm or cold air within a building.
The effective ventilation of dwellings and commercial offices is an essential
requirement. It is known to construct ventilation systems using rigid plastic ducting
10 and plastic accessories, which are of a modular nature and are designed to be push-
fitted together so that multiple layouts are possible to meet almost any installation
configuration.

As ventilation systems become more complex, ductwork complexity increases and
15 longer lengths of duct and many more joints between connecting accessories and
ductwork elements, such as elbow bends, tee pieces, system adaptors, are required.

Moreover, all new installations have to be performance tested on completion and must
achieve pre-determined airflows at extract and supply points to meet any applicable
20 standards or Building Regulations. This means that air leakage at the joints has become
a major concern because leakage will adversely affect the air flow performance and
balance of the system. If the installed performance does not achieve the minimum
design performance, expensive remedial work may be required.

25 Traditionally, significant air leakage at the joints has been accepted in the industry, but
as the required standards of performance increase, the industry is resorting to
elementary methods of reducing leakage such as permanently sealing the joints with
adhesive, using silicon sealant or other sealants to fill the joints and/or wrapping pvc or
aluminium adhesive tape around the joint seams.

30 These elementary solutions are undesirable, because they are messy to execute when
installing the ductwork or applying retrospectively to reduce leakage and can be
expensive in terms of installation time. In addition, they are not readily reversible if a
joint has to be broken and re-made for maintenance or alteration.

35

The present invention seeks to provide a coupling that overcomes or substantially alleviates the problems with conventional techniques for coupling ductwork components and accessories to each other and seeks to provide a joint with minimal air leakage.

5

According to the invention, there is provided a coupling for interconnecting ventilation ductwork elements together during assembly of a ventilation ductwork system, the coupling comprising an outer wall defining a socket sized to slideably receive and support the end of a ductwork element therein and releasably connect said ductwork
10 element to the coupling, wherein the socket includes a sealing member against said outer wall configured to resiliently deform and engage the ductwork element as the ductwork element is received in said socket to form a substantially airtight seal between the coupling and the ductwork element.

15 Preferably, the sealing member is integrally formed and comprises a primary and secondary sealing portion. The sealing member is preferably integrally formed.

The sealing member may be configured so that the secondary sealing portion initially engages a ductwork element as a ductwork element is inserted into the socket and
20 before the primary sealing portion engages the ductwork element. The secondary sealing portion makes initial contact with the ductwork element being inserted and so guides and supports the ductwork element during further insertion and before it comes into contact with the primary sealing portion.

25 In a preferred embodiment, the primary sealing portion comprises a flap that is resiliently deformed or bent by the ductwork element during further insertion into the socket beyond the secondary sealing portion and so that said flap is biased into engagement with the ductwork element so as to form a primary seal between the socket and the ductwork element. Although the secondary sealing portion does provide some
30 level of seal between the coupling member and the ductwork element, its main function is to guide and support the ductwork element during insertion and so that it is centralised and correctly positioned prior to engagement with the primary sealing portion. The primary sealing portion forms the main seal against the egress of air from a ventilation system that is coupled using the coupling of the invention.

35

The secondary sealing portion comprises a domed or triangular shaped element that forms a secondary seal between the socket and the ductwork element and guides a ductwork element into the socket and towards the primary sealing portion during insertion. The secondary sealing portion may be biased against the ductwork element with a biasing force which is less than the biasing force generated by the primary
5 sealing portion against the ductwork element.

In preferred embodiments, the socket comprises a seat to receive said sealing member and the coupling further comprises a retaining ring to locate the sealing member in said
10 seat.

The retaining ring may contact the sealing member. Preferably, the retaining ring is formed from a resilient material that forms a snap-fit over an end of the socket. The retaining ring may be removable to enable a sealing member to be removed and
15 replaced.

In a preferred embodiment, the socket may further comprise an inner wall that is spaced from and faces the sealing member so as to define a slot between the inner and outer walls to receive a ductwork element therein. The ductwork element may be a
20 friction fit in the slot and so the outer wall provides additional support for the ductwork element and/or helps maintain the coupling and the ductwork element in engagement.

In some embodiments, the free end of the inner wall may have a chamfered edge to guide a ductwork element into the slot during insertion.

25

According to the invention, there is also provided a ventilation ductwork system comprising a plurality of ventilation ductwork elements coupled together with a plurality of couplings according to the invention.

30 According to another aspect of the invention, there is provided a ventilation ductwork element comprising an integral coupling for interconnecting said ventilation ductwork element to a second ventilation ductwork element during assembly of a ventilation ductwork system, the integral coupling comprising an outer wall defining a socket sized to slideably receive and support the end of a second ventilation ductwork element
35 therein and releasably connect said second ventilation ductwork element to the ventilation ductwork element, wherein the socket includes a sealing member in said

outer wall configured to resiliently deform and engage a second ventilation ductwork element as a second ventilation ductwork element is received in said socket to form a substantially airtight seal between the ventilation ductwork element and a second ventilation ductwork element.

5

According to the invention, there is also provided a ventilation ductwork system comprising a plurality of coupled together ventilation ductwork elements according to the invention.

10

According to another aspect of the invention, there is also provided a method of manufacturing a coupling for interconnecting ventilation ductwork elements together during assembly of a ventilation ductwork system, the coupling comprising an outer wall defining a socket sized to slideably receive and support the end of a ductwork element therein and releasably connect said ductwork element to the coupling,

15

including the step of inserting a sealing member into said socket against said outer wall so that said sealing element will resiliently deform and engage a ductwork element as a ductwork element is received in said socket to form a substantially airtight seal between the coupling and the ductwork element.

20

The method may include the step of attaching a retaining ring to the coupling to retain the sealing element in position in the socket.

Embodiments of the invention will now be described, by way of example only, with reference to the accompanying drawings, in which:

25

Figure 1 is a perspective view of a coupling according to an embodiment of the invention;

Figure 2 is a cross-section through the coupling illustrated in Figure 1;

Figure 3 is a perspective view of another coupling according to an embodiment of the invention;

30

Figure 4 is a cross-section through part of the sealing element used in the coupling of Figures 1 to 3; and

Figure 5 illustrates a ventilation ductwork element incorporating integral couplings according to another embodiment of the invention.

35

Referring now to the drawings, there is shown in Figure 1 a round pipe coupling 1 according to an embodiment of the invention which is used to couple a ventilation pipe

(not shown) to a ventilation accessory (not shown) such as elbow bends, T-pieces and other adaptors, or to connect two lengths of round ventilation ducting together. A similar coupling 1, but rectangular in shape, used for connecting rectangular shaped ductwork or accessories is shown in Figure 3. It will be appreciated that the coupling and ductwork elements may be of any complementary shape. The coupling 1 is made of injection moulded rigid plastics material of sufficient stiffness and durability such that the coupling is self-supporting.

The coupling 1 shown in Figure 1 is primarily used to connect a length of ventilation duct pipework having a first diameter to an accessory which is of reduced diameter. Consequently, the coupling 1 has a first socket 2 to receive an end of the duct pipework and, a second socket 3 at its other end which is of reduced diameter to match the diameter of the accessory to which the pipework is to be coupled. However, it will be appreciated that the coupling 1 can also be used to connect two identical runs of duct pipework together, in which case the sockets 2, 3 will be of equal size.

The coupling 1 has a body 4 having an outer wall 5 and an inner wall 6. Each end of the body 4 is open so as to form the socket 2,3 to receive a ductwork element or accessory to be connected to the coupling 1. The inner wall 6 is joined to the outer wall by a centrally positioned web 7 and extends from said web 7 in opposite directions so that each socket 2,3 includes a slot 8, 9 to receive the end of a ductwork element when inserted into the socket 2,3. The slot 8, 9 may be of a predetermined size so that the ductwork element will be a snug or relatively tight sliding fit therein so that the inner wall 6 helps to support the ductwork element within the socket 2, 3. Preferably, the free ends of the inner wall 4 have chamfered regions 6a to assist in guiding the ductwork element into the slot 8, 9.

It will be appreciated that the inner wall 6 provides strength and rigidity to the coupling and additional support to the ductwork element. As the shape of the end of the ductwork element may not be an exact match to the shape of the coupling into which it is to be pushed, the inner wall 6 guides and re-shapes the end of the ductwork element as it is inserted into the socket 2, 3 and pulls it into the correct shape so that it will properly seal against the sealing element 12. More specifically, if the coupling is round, the end of a ductwork element, such as a pipe, for insertion into the coupling may not be completely round. However, when the end of the pipe is inserted into the socket 2, 3 the inner wall 6 assists in pulling or deforming the end of the pipe back into a more

perfectly round shape prior to contact with the sealing member 12 during further insertion into the socket 2, 3. The inner wall 6 also streamlines and provides the inner surface of the coupling with a more aerodynamic profile to minimise pressure loss that would occur if the coupling were to cause turbulence in the air flow.

5

Each socket 2, 3 comprises a rim 10 defined by a thinning of the outer wall 5 that forms a seat 11 to receive and mount a sealing element 12. A cap 13 fits over the end of each rim 10 and has a hooked portion 13a that extends radially inwardly over an end region of the sealing element 12 to retain the sealing element 12 in its seat 11. The cap 13 is preferably formed from a resiliently deformable material and is a snap fit over the rim 10 of the body 4 of the coupling 1. The cap 13 may be removable to facilitate the replacement of the sealing element 12.

15 The sealing element 12 is illustrated in more detail in the cross-sectional view of Figure 4. The sealing member 12 is integrally moulded from a thermoplastic elastomer with dynamic performance and good compression set at operating temperatures. It comprises a primary sealing portion 14 and a secondary sealing portion 15. As shown in Figure 4, the secondary sealing portion 15 has a generally dome-shaped profile. The sealing member 12 is positioned so that the ductwork element will make initial contact 20 with the surface of the dome as it is inserted into the socket 2, 3. This will cause the secondary sealing portion 15 to become resiliently compressed and biased into contact with the ductwork element. Although the secondary sealing portion 15 will make an effective seal with the ductwork element, the main seal is formed by the primary sealing portion 14 of the sealing member 12 and the secondary sealing portion 15 serves to 25 support and guide the ductwork element as it is inserted into the socket 2,3 in the coupling 1.

The primary sealing portion 14 comprises a flap 16 of resilient material that extends upwardly at an angle into the slot 8, 9. As the end of the ductwork element is pushed 30 into the socket 2, 3, it contacts the flap 16 and pushes and bends it downwardly so that the ductwork element can pass over it and fully home into the socket 2,3 until it reaches the connecting web 7. When the ductwork element is fully home, the flap 16 formed by the primary sealing portion 14 lies biased into engagement with the ductwork element thereby effecting a primary seal preventing the escape of air through the coupling. The 35 flap 16 may be pushed down against the surface of the outer wall 5 by the ductwork

element so that it is effectively squashed between the ductwork element and the outer wall 5, thereby enhancing the sealing effect provided by the primary sealing portion 14.

5 It will be noted that the coupling forms a self-seal or seals automatically as a direct result of pushing a ductwork element into the coupling without any additional steps and without any requirement to use any sealant or other materials.

10 Although Figures 1 to 3 show a coupling for attaching two ductwork elements together, it will be appreciated that the coupling 1 could be integrally formed with a ductwork element so that two components may be connected together directly, without any intermediate coupling between them. A 90 degree pipe coupling accessory 20 is shown in Figure 5 which has been formed with a coupling 1 at each end that includes the inner wall 6 and the sealing member 12 as previously described. It will be appreciated that a ductwork element can include lengths of pipework, joints or T-pieces of any shape and includes any ventilation components that need to be connected together to form a
15 ventilation system for carrying air around a premises.

The self-seal coupling of the invention is intended for plastic ventilation ducting in round ducts having an internal diameter of between 80 to 200mm. The wall thickness
20 may range from 1.2mm to 2.0mm. However, it will be appreciated that the coupling of the invention is applicable to round ducts of any diameter and wall thickness. For rectangular ducts, it may be used for ducts of any size although is intended for use with ducts having the outer dimensions 110mm x 54mm, 150mm x 70mm, 180mm x 95mm , 204mm x 60mm and 220mm x 90mm, in addition to any other rectangular size in
25 between and with wall thicknesses ranging from 1.2mm to 2.0mm.

It will be appreciated that the foregoing description is given by way of example only and that modifications may be made to the support assembly of the present invention without departing from the scope of the appended claims.

30

Claims

1. A coupling for interconnecting ventilation ductwork elements together during assembly of a ventilation ductwork system, the coupling comprising an outer wall defining a socket sized to slideably receive and support the end of a ductwork element therein and releasably connect said ductwork element to the coupling, wherein the socket includes a sealing member against said outer wall configured to resiliently deform and engage the ductwork element as the ductwork element is received in said socket to form a substantially airtight seal between the coupling and the ductwork element.
2. A coupling according to claim 1, wherein the sealing member is integrally formed and comprises a primary and secondary sealing portion.
3. A coupling according to claim 2, wherein the sealing member is configured so that the secondary sealing portion initially engages a ductwork element as a ductwork element is inserted into the socket and before the primary sealing portion engages the ductwork element.
4. A coupling according to claim 3, wherein the primary sealing portion comprises a flap that is resiliently deformed or bent by the ductwork element during further insertion into the socket beyond the secondary sealing portion and so that said flap is biased into engagement with the ductwork element so as to form a primary seal between the socket and the ductwork element.
5. A coupling according to claim 4, wherein the secondary sealing portion comprises a domed or triangular shaped element that forms a secondary seal between the socket and the ductwork element and guides a ductwork element into the socket and towards the primary sealing portion during insertion.
6. A coupling according to any preceding claim, wherein the socket comprises a seat to receive said sealing member, the coupling further comprising a retaining ring to locate the sealing member in said seat.

7. A coupling according to claim 6, wherein the retaining ring contacts said sealing member and is formed from a resilient material that forms a snap-fit over an end of the socket.
- 5 8. A coupling according to any preceding claim, wherein the socket further comprises an inner wall that is spaced from and faces the sealing member so as to define a slot between the inner and outer walls to receive a ductwork element therein.
9. A coupling according to claim 9, wherein a free end of the inner wall has a chamfered edge to guide a ductwork element into the slot during insertion.
- 10 10. A ventilation ductwork system comprising a plurality of ventilation ductwork elements coupled together with a plurality of couplings according to any of claims 1 to 9.
- 15 11. A ventilation ductwork element comprising an integral coupling for interconnecting said ventilation ductwork element to a second ventilation ductwork element during assembly of a ventilation ductwork system, the integral coupling comprising an outer wall defining a socket sized to slideably receive and support the end of a second ventilation ductwork element therein and releasably connect said second ventilation ductwork element to the ventilation ductwork element, wherein the socket includes a sealing member in said outer wall configured to resiliently deform and engage a second ventilation ductwork element as a second ventilation ductwork element is received in said socket to form a substantially airtight seal between the ventilation ductwork element and a second ventilation ductwork element.
- 20 25 12. A ventilation ductwork system comprising a plurality of ventilation ductwork elements according to claim 10 coupled together.
- 30 13. A method of manufacturing a coupling for interconnecting ventilation ductwork elements together during assembly of a ventilation ductwork system, the coupling comprising an outer wall defining a socket sized to slideably receive and support the end of a ductwork element therein and releasably connect said ductwork element to the coupling, including the step of inserting a sealing member into said socket against said outer wall so that said sealing element will resiliently deform and engage a ductwork
- 35

element as a ductwork element is received in said socket to form a substantially airtight seal between the coupling and the ductwork element.

14. A method according to claim 13, comprising the step of attaching a retaining
5 ring to the coupling to retain the sealing element in position in the socket.

15. A coupling substantially as hereinbefore described with reference to the accompanying drawings.

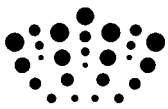

Application No: GB1301481.6

Examiner: Stephen Hart

Claims searched: 1 - 14

Date of search: 6 July 2013

Patents Act 1977: Search Report under Section 17

Documents considered to be relevant:

Category	Relevant to claims	Identity of document and passage or figure of particular relevance
X	1, 6, 8 & 10 - 14	KR 100877141 B (KOO et al.) 07.01.09 (see fig 2, EPODOC Abstract & WPI Abstract Accession No. 2009-F89737), noting a ventilation duct 2 received in a groove 1a (socket) of a connector 1 (coupling) and packing 4 (seal) held in place by an anti-separation member 3a (retaining ring).
X	1 & 8 - 13	DE 10019330 A1 (MANN & HUMMEL FILTER) 25.10.01 (see fig 2, EPODOC Abstract & WPI Abstract Accession No. 2001-617774).
X	1, 2 & 10 - 13	SU 1670301 A1 (LUTSYUK et al.) 15.08.91 (see fig 1 and WPI Abstract Accession No. 1992-181880).

Categories:

X Document indicating lack of novelty or inventive step	A Document indicating technological background and/or state of the art.
Y Document indicating lack of inventive step if combined with one or more other documents of same category.	P Document published on or after the declared priority date but before the filing date of this invention.
& Member of the same patent family	E Patent document published on or after, but with priority date earlier than, the filing date of this application.

Field of Search:

Search of GB, EP, WO & US patent documents classified in the following areas of the UKC^X :

--

Worldwide search of patent documents classified in the following areas of the IPC

F24F

The following online and other databases have been used in the preparation of this search report

Online: WPI, EPODOC

International Classification:

Subclass	Subgroup	Valid From
None		