

(12) UK Patent Application (19) GB (11) 2 360 066 (13) A

(43) Date of A Publication 12.09.2001

(21) Application No 0005361.1

(22) Date of Filing 06.03.2000

(71) Applicant(s)  
**The Boc Group plc**  
**(Incorporated in the United Kingdom)**  
**I.P. Department, Chertsey Road, WINDLESHAM,**  
**Surrey, GU20 6HJ, United Kingdom**

(72) Inventor(s)  
**Martin Nicholas Stuart**

(74) Agent and/or Address for Service  
**R.G.C.Jenkins & Co**  
**26 Caxton Street, LONDON, SW1H 0RJ,**  
**United Kingdom**

(51) INT CL<sup>7</sup>  
**F04D 25/16 19/04**

(52) UK CL (Edition S )  
**F1C CBA CBB CBE CBF C103 C109 C114 C307 C601**

(56) Documents Cited  
**EP 0919726 A1 EP 0226039 A1 US 5733104 A**  
**US 5707213 A**

(58) Field of Search  
**UK CL (Edition R ) F1C CBA CBB CBE CBF**  
**INT CL<sup>7</sup> F04D 19/02 19/04 25/00 25/16**  
**ONLINE: EPODOC, JAPIO, WPI**

(54) Abstract Title  
**Vacuum pump**

(57) A vacuum pump has a first pumping unit 30 having an inlet side 32 and an outlet side 34. This unit comprises a turbo molecular pumping arrangement 12 and a molecular drag pumping arrangement 14. In series with this first pumping unit 30 is a second pumping unit 36 having an inlet side 38 and an outlet side 40. This second unit comprises at least one molecular pumping arrangement 16. The pump has a first suction port 42 in flow communication with the inlet side 32 of said first unit 30 and a second suction port 44 in flow communication with said outlet side 34 of said first unit 30 and said inlet side 38 of said second unit 36. Reference is made to a pump comprising three or more pumping units.

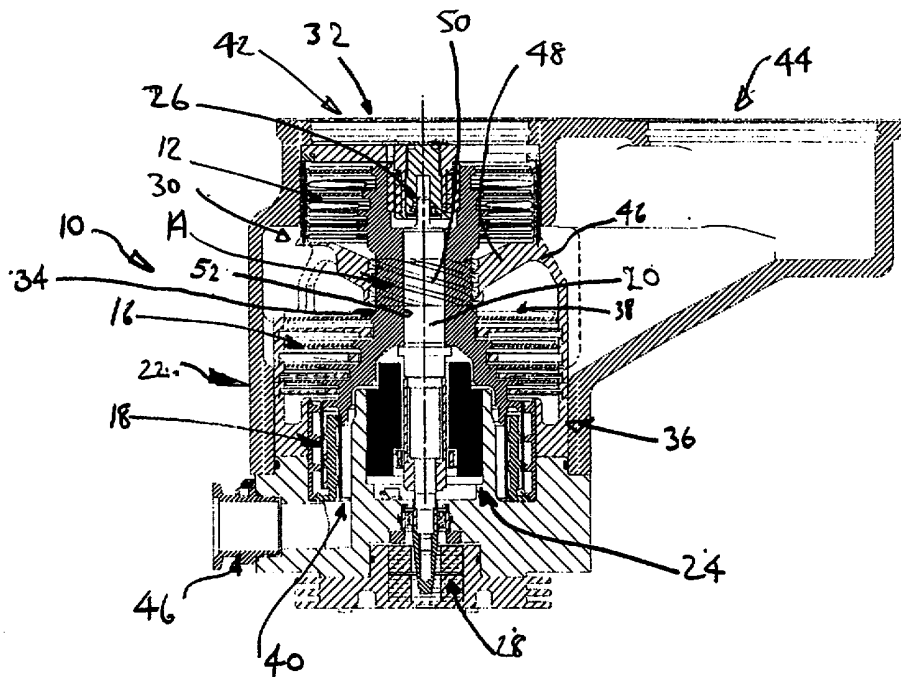

GB 2 360 066 A

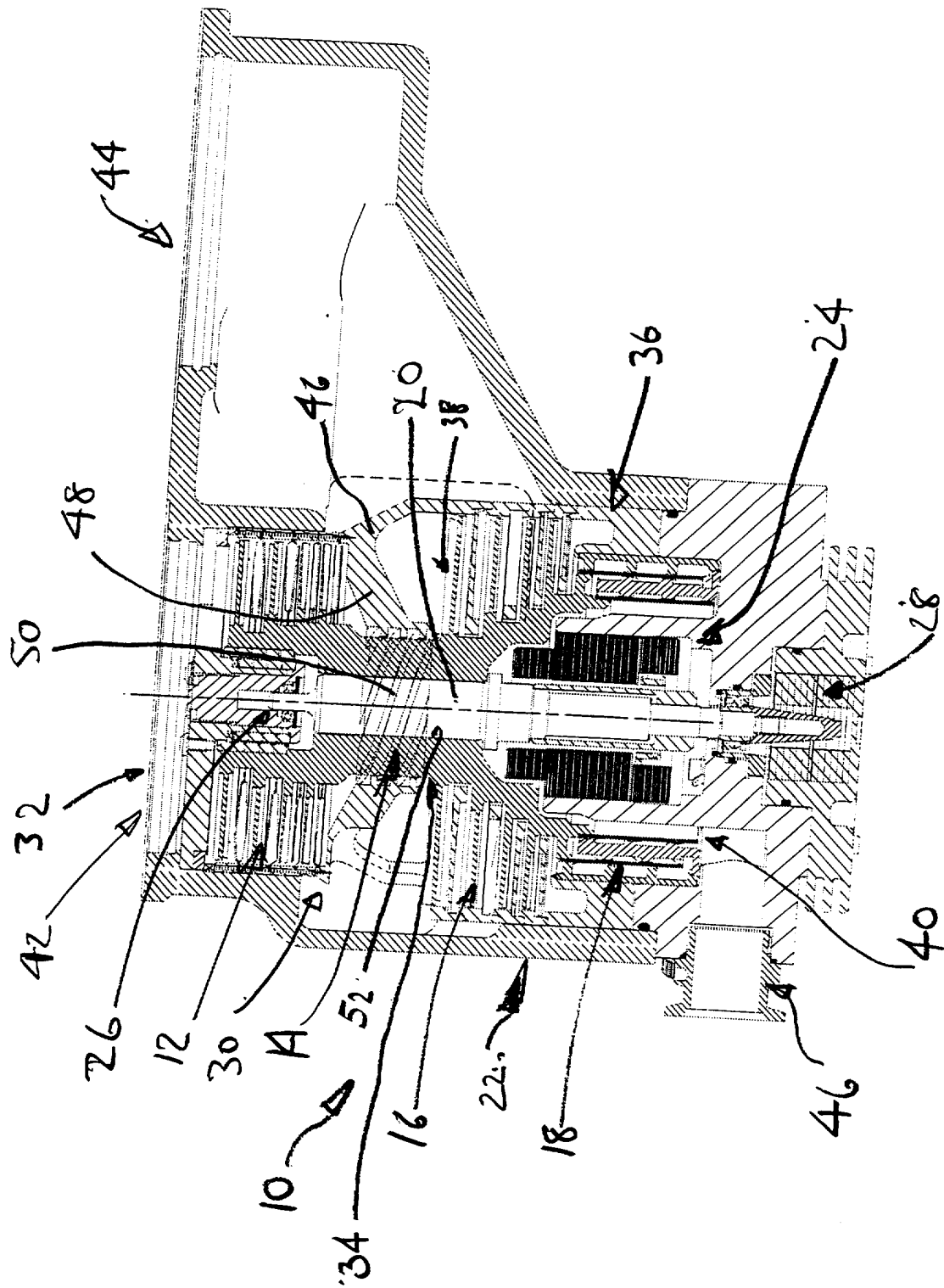

### Vacuum Pump

This invention relates to a vacuum pump and in particular to a vacuum pump having at least two suction ports for providing different levels of vacuum.

EP-A-0919726, to which reference is directed, discloses such a vacuum pump in which a plurality of molecular pumping arrangements are arranged in series. This pump has a first suction port in flow communication with the inlet side of a first molecular pumping arrangement formed as a turbo-molecular pumping arrangement for gas which is to pass through all of the molecular pumping arrangements and a second suction port which communicates with the outlet side of the first molecular pumping arrangement and the inlet side of the second molecular pumping arrangement immediately downstream of the first molecular pumping arrangement for gas which is to pass through the second molecular pumping arrangement and any pumping arrangements downstream thereof. The first and second suction ports are connected to respective first and second vacuum chambers for providing vacuum in the first vacuum chamber which is higher than the vacuum provided in the second vacuum chamber. As disclosed in EP-A-0919726 these chambers may be chambers of a mass spectrometer.

The design of pump disclosed in EP-A-0919726 is appropriate for mass spectrometer systems where comparatively large diatomic gas molecules (eg nitrogen) predominate since the compression ratio between the first and second suction ports across the turbo-molecular pumping arrangement is sufficiently large. However, it is envisaged that in future mass spectrometer

systems, smaller monatomic gases (eg helium) may predominate, in which case the compression ratio between the first and second suction ports will or may not be sufficient for the mass spectrometer system to function.

In order to overcome this potential problem it is proposed to add  
5 another pumping arrangement between the first and second suction ports.

Specifically, in an embodiment of the invention comprising a modification of the vacuum pump disclosed in EP-A-0919726 a molecular drag pumping arrangement is added between the first and second suction ports. This combination of a turbo molecular pumping arrangement and a  
10 molecular drag pumping arrangement forms a first pumping unit of the vacuum pump, which unit comprises a compound pump arrangement.

The invention is applicable to vacuum pumps other than that disclosed in EP-A-0919726 and in accordance with one aspect of the invention, there is provided a vacuum pump comprising a first pumping unit having an inlet side  
15 and an outlet side and comprising a turbo molecular pumping arrangement and a molecular drag pumping arrangement and in series with said first pumping unit a second pumping unit having an inlet side and an outlet side and comprising at least one molecular pumping arrangement, said pump having a first suction port in flow communication with the inlet side of said  
20 first unit and a second suction port in flow communication with said outlet side of said first unit and said inlet side of said second unit.

The invention also includes a pump as defined in the last preceding paragraph having its first and second suction ports connected to respective first and second vacuum chambers for providing vacuum in the first vacuum

chamber which is of lower pressure than the vacuum provided in the second vacuum chamber.

The second pumping unit of the pump may comprise a turbo molecular pumping arrangement alone or such an arrangement followed by a molecular drag pumping arrangement (ie a molecular compound pumping arrangement).

The vacuum pump may include in series with said first and second pumping units a third pumping unit having an inlet side and an outlet side and comprising at least one molecular pumping arrangement, said pump having a third suction port in flow communication with said outlet side of said second unit and said inlet side of said third unit.

The second suction port may include a perforate bridge extending between respective stators of the turbo molecular pumping arrangement of said first unit and the or a said molecular pumping arrangement of the second unit. The molecular drag pumping arrangement of the first pumping unit may comprise a Holweck drag mechanism in which case advantageously the bridge may include an annular member disposed about a rotary drive shaft of said pump for directing gas from said turbo molecular pumping arrangement into said Holweck drag mechanism, said annular member forming a stator for said Holweck drag mechanism.

The bridge may be axially split for fitting about said rotary drive shaft.

The invention also includes a vacuum pump comprising at least three pumping arrangements disposed in series, each of which pumping arrangement has an inlet side and an outlet side; a first suction port which communicates with the inlet side of a first one of said pumping arrangements for gas which is to pass through all of said pumping arrangements; and a

further suction port which communicates with the outlet side of a second pumping arrangement which is immediately adjacent to the first pumping arrangement and the inlet side of a third pumping arrangement immediately downstream thereof for gas which is to pass through the third pumping arrangement and any pumping arrangements downstream thereof, wherein the pump is arranged such that the inlet side of the second pumping arrangement receives gas only from the outlet side of said first pumping arrangement.

Preferably said pumping arrangements have a common rotary shaft and said second pumping arrangement comprises a Holweck drag mechanism for which the common rotary shaft forms the rotor.

In order that the invention may be well understood a presumably preferred embodiment, which is given by way of example only will now be described with reference to the accompanying drawing which is an axial cross-section of a vacuum pump.

With reference to the drawing, there is shown a vacuum pump comprising four pumping arrangements 12, 14, 16 and 18 having a common drive shaft 20 and disposed in series in a common multi-component body 22. The drive shaft 20 is driven by an electric motor generally referenced 24 and the position of the shaft 20 is controlled by upper and lower bearings 26 and 28 in a known manner.

Each of the pumping arrangements 12 and 16 is a turbo molecular pumping arrangement comprising a stack of alternate rotor and stator blades, the rotor blades being driven by the rotary drive shaft 20.

Each of the pumping arrangements 14 and 18 comprises a molecular drag pumping arrangement, and specifically such an arrangement comprising a Holweck drag mechanism.

5 The pumping arrangements 12 and 14 form a first pumping unit 30 having an inlet side 32 and an outlet side 34. The pumping arrangements 16 and 18 form a second pumping unit 36 in series with the first unit 30 and having an inlet side 38 and an outlet side 40.

10 The pump has a first suction port 42 in flow communication with the inlet side 32 of the first unit 30 and a second suction port 44 in flow communication with the outlet side 34 of the first unit and the inlet side 38 of the second unit 36. The pump also has a discharge port 46 in flow communication with the outlet side 40 of the second unit. Typically in use discharge port 46 is connected to a backing, or fore, pump which discharges to atmosphere.

15 It will be noted that gas which passes into the pump through the first suction port 42 passes through all four pumping arrangements 12 to 18 before discharging through discharge port 42 whilst gas which passes into the pump through the second suction port passes through the pumping arrangements 16 and 18 of the second unit before discharging through the discharge port 42. It  
20 is also to be noted that there is no suction port communicating with the outlet side of pumping arrangement 12 and inlet side of pumping arrangement 14. Thus the inlet side of pumping arrangement 14 receives gas only from the outlet side of pumping arrangement 12.

Similarly, in the illustrated embodiment the inlet side of pumping arrangement 18 of the second unit receives gas only from the outlet side of pumping arrangement 16.

5 The second suction port 44 includes a perforate bridge 46 extending between respective stators of the turbo molecular pumping arrangement 12 of the first unit 30 and the turbo molecular pumping arrangement 16 of the second unit 36. This bridge includes an annular member 48 disposed about the rotary shaft 20 of the pump for directing gas from the turbo molecular pumping arrangement 12 of the first unit into the Holweck drag mechanism 10 14 of the first unit. The annular member forms a stator for the Holweck drag mechanism and comprises a radially inwardly open helical channel 50 which cooperates with a cylindrical part 52 of the rotary drive shaft 20. This cylindrical part 52 has a smaller diameter than the parts of the shaft on each axial side thereof and accordingly the bridge is axially split for fitting about 15 the shaft.

It will be understood that in use the suction ports 42 and 44 are connected to respective first and second chambers (not shown) for providing vacuum in the first chamber which is of lower pressure than the vacuum in the second chamber. The addition of the molecular drag pumping arrangement 14 20 increases the difference in the levels of vacuum in the chambers.

Whilst the embodiment is provided with two suction ports for connection to respective chambers, the pump may be modified to provide more than two suction ports. For example, a third suction port may be provided between the two molecular pumping arrangements 16 and 18 of the 25 second pumping unit 36. Additionally or alternatively a third pumping unit



having an inlet side and an outlet side and comprising at least one molecular pumping arrangement may be provided in series with the first and second units in which case a third suction port in flow communication with the outlet side of the second unit and the inlet side of the third unit may be provided. Of course, further pumping units and associated suction ports may be similarly provided in series with the above-mentioned three units to increase the number of chambers which may be evacuated.

It is also to be understood that although described in relation to a vacuum pump having molecular pumping arrangements the invention is not so limited.

CLAIMS:

1. A vacuum pump comprising a first pumping unit having an inlet side and an outlet side and comprising a turbo molecular pumping arrangement and a molecular drag pumping arrangement and in series with said first  
5 pumping unit a second pumping unit having an inlet side and an outlet side and comprising at least one molecular pumping arrangement, said pump having a first suction port in flow communication with the inlet side of said first unit and a second suction port in flow communication with said outlet  
10 side of said first unit and said inlet side of said second unit.
2. A pump as claimed in claim 1, including in series with said first and second pumping units a third pumping unit having an inlet side and an outlet side and comprising at least one molecular pumping arrangement, said pump  
15 having a third suction port in flow communication with said outlet side of said second unit and said inlet side of said third unit.
3. A pump as claimed in claim 1 or 2, wherein said second suction port includes a perforate bridge extending between respective stators of the turbo  
20 molecular pumping arrangement of said first unit and the or a said molecular pumping arrangement of the second unit.

4. A pump as claimed in claim 1, 2 or 3 wherein said molecular drag pumping arrangement comprises a Holweck drag mechanism.

5. A pump as claimed in claim 4 when appended to claim 3, wherein said  
5 bridge includes an annular member disposed about a rotary drive shaft of said pump for directing gas from said turbo molecular pumping arrangement into said Holweck drag mechanism, said annular member forming a stator for said  
Holweck drag mechanism.

10 6. A pump as claimed in claim 5, wherein said bridge is axially split for fitting about said rotary drive shaft.

7. An installation comprising a pump as claimed in any one of the preceding claims having its first and second suction ports connected to  
15 respective first and second vacuum chambers for providing vacuum in the first vacuum chamber which is of lower pressure than the vacuum provided in the second vacuum chamber.

8. A vacuum pump comprising at least three pumping arrangements  
20 disposed in series, each of which pumping arrangement has an inlet side and an outlet side; a first suction port which communicates with the inlet side of a first one of said pumping arrangements for gas which is to pass through all of

said pumping arrangements; and a further suction port which communicates with the outlet side of a second pumping arrangement which is immediately adjacent the first pumping arrangement and the inlet side of a third pumping arrangement immediately downstream thereof for gas which is to pass through the third pumping arrangement and any pumping arrangements downstream thereof, wherein the pump is arranged such that the inlet side of the second pumping arrangement receives gas only from the outlet side of said first pumping arrangement.

10 9. A vacuum pump as claimed in claim 8, wherein said pumping arrangements have a common rotary shaft and said second pumping arrangement comprises a Holweck drag mechanism for which the common rotary shaft forms the rotor.

15 10. A vacuum pump substantially as hereinbefore described with reference to the accompanying drawings.



INVESTOR IN PEOPLE

Application No: GB 0005361.1  
Claims searched: 1-7

Examiner: C.B. VOSPER  
Date of search: 28 November 2000

### Patents Act 1977 Search Report under Section 17

#### Databases searched:

UK Patent Office collections, including GB, EP, WO & US patent specifications, in: UK CI (Ed.R): F1C(CBA,CBB,CBE,CBF) Int CI (Ed.7): F04D 19/02,19/04, 25/00,25/16 Other: ONLINE: EPODOC,JAPIO,WPI
---

#### Documents considered to be relevant:

Category	Identity of document and relevant passage	Relevant to claims
Y	EP 0919726 A1 BOC (whole document; discloses vacuum pumping unit having both turbomolecular and molecular drag arrangements as well as a second suction port 16, between two pumping units 6, 7)	1 and 4
Y	EP 0226039 A1 HITACHI (fig. 1; shows vacuum pump with second suction port 17, between two pumping units 5, 6)	1 and 4
Y	US 5733104 BALZERS (fig. 2; second suction port 9, communicating with outlet of first unit 4, comprising a turbomolecular pump 5, and molecular drag pump 6, and with the inlet of a second unit 8.)( Equivalent = EP0603694)	1 and 4
Y	US 5707213 BALZERS (figure; shows second suction port 13, between first and second molecular pumping units 1,4)	1 and 4

X Document indicating lack of novelty or inventive step	A Document indicating technological background and/or state of the art.
Y Document indicating lack of inventive step if combined with one or more other documents of same category.	P Document published on or after the declared priority date but before the filing date of this invention.
& Member of the same patent family	E Patent document published on or after, but with priority date earlier than, the filing date of this application.