

T. F. CUDDY.
PULLEY SHAFT.

APPLICATION FILED JAN. 4, 1904.

NO MODEL

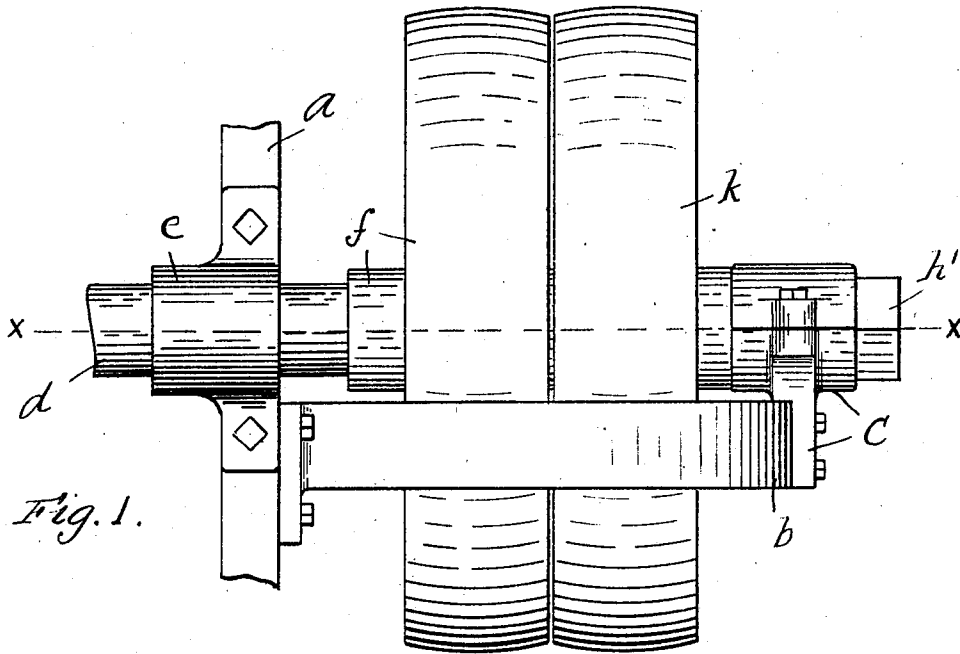

Fig. 1.

Fig. 3.



Fig. 4.



Fig. 2.

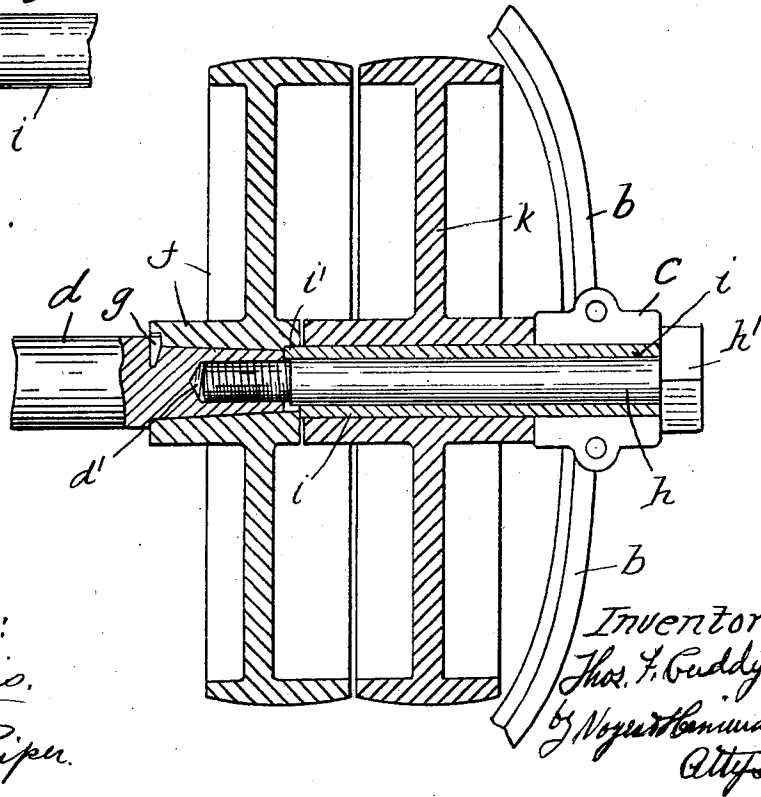

Witnesses:
H. B. Davis.
Maud M. Piper.

Inventor:
Thos. F. Cuddy
by Noyes & Boniman
Attys

UNITED STATES PATENT OFFICE.

THOMAS F. CUDDY, OF LAWRENCE, MASSACHUSETTS.

PULLEY-SHAFT.

SPECIFICATION forming part of Letters Patent No. 754,052, dated March 8, 1904.

Application filed January 4, 1904. Serial No. 187,643. (No model.)

To all whom it may concern:

Be it known that I, THOMAS F. CUDDY, of Lawrence, county of Essex, State of Massachusetts, have invented an Improvement in Pulley-Shafts, of which the following description, in connection with the accompanying drawings, is a specification, like characters on the drawings representing like parts.

In spinning and twisting frames it is customary to employ pulleys of different sizes upon the drum or cylinder which drives the spindles, so that the twist per inch of the yarn may be varied. Inasmuch as it requires considerable power to drive the drum it is necessary that the shaft to which the drum is secured be journaled in bearings which are located closely adjacent the inner end of the hub of the tight pulley and the outer end of the hub of the loose pulley, with which the shaft is usually provided. In machines of this character it has been customary to support the outer bearing by means of a yoke which is bolted to the end frame or support, and, so far as I am aware, the method of changing the pulleys has been to unbolt this yoke from the frame, remove the bearing from the shaft, slide the pulleys from the shaft, then place a different set of pulleys on the shaft, and replace the yoke. With such a construction it has been found to be extremely difficult to set the bearing in alinement readily, so that the shaft will run smoothly. The result is that, aside from the expense and delay occasioned by the labor of changing the pulleys and the loss of the time during which the machine might otherwise be operated, much power is lost by reason of the fact that the bearing is not again placed in correct alinement.

The object of my invention is to provide a form of shaft which will enable the pulleys to be removed and replaced conveniently and quickly without disturbing the outer bearing. The manner in which I accomplish this object is disclosed in the accompanying drawings, in which—

Figure 1 is a side elevation of the end bearings of a spinning-frame provided with my invention. Fig. 2 is a section on line *xx* of Fig. 1. Figs. 3 and 4 are detail views of the end of the sleeve.

a represents the end support of a spinning or twisting frame or like device, and *b* a yoke which is secured at each end to the frame *a*, said yoke having a bearing *c* in the middle portion thereof. The shaft *d*, which carries the usual driving cylinder or drum, is journaled at its outer end in a bearing *e*, mounted in the support *a*, and the extreme end portion of said shaft is tapered slightly to receive the correspondingly-tapered hub of the tight pulley *f*, which is driven thereon. A key *g* is provided in the shaft, which engages a correspondingly-shaped recess in the hub of the pulley *f*, so as to hold the pulley from turning on the shaft, and a stud *h*, having a flat-sided head *h'*, is screw-threaded at its inner end and is screwed into a correspondingly-threaded recess *d'* in the outer end of the shaft *d*. A bearing-sleeve *i* is mounted on the stud *h* and journaled in the bearing *c*, the outer end of said sleeve engaging the inner side of the head *h'* of the stud, the inner end thereof being pressed against the outer end of the hub of the tight pulley *f*, so that when the stud is screwed into the recess *d'* as far as possible the sleeve *i* will securely hold the pulley in place. A projection or extension *i'* is provided on the inner end of sleeve *i*, and the outer end of the hub of the fast pulley is provided with a correspondingly-shaped recess, in which said extension is located. A loose pulley *k* is journaled on the sleeve *i* between the tight pulley and the bearing *c*. As the stud and sleeve are thus securely connected to the shaft and as they are rotatably mounted in the outer bearing, they practically form a shaft extension which has the same effect, so far as the ordinary running of the shaft is concerned, as if the shaft were continued through the outer bearing.

With my invention the manner of removing and replacing the pulleys *f* and *k* is as follows: The stud *h* is first unscrewed from the shaft *d*, and then the stud and sleeve are slipped along in the bearing *c* and from within the loose pulley *k* until the latter may be lowered from between the arms of the yoke and removed. Then the tight pulley *f* will be removed from the end of the shaft *d*, enabling it to be lowered in the same manner as the pulley *k*. The pulley which is to be placed on the shaft *d* is

then forced onto the tapered end of the shaft, the loose pulley is lifted into position, the sleeve *z* is passed through it, then the stud is passed through the sleeve and is screwed into the shaft again, securing the parts in position without in any way disturbing the bearing *c* or necessitating the removal of the yoke.

While under some conditions I may prefer to make the sleeve and stud in one piece, yet when the loose pulley is rotated in a direction to unscrew the stud and if from lack of proper lubrication said pulley should stick on the stud the latter would be unscrewed, permitting the pulley to fall.

Such an occurrence would be likely to cause damage and possibly injury to operatives. By providing the extension *z'* on the sleeve, which engages a recess in the end of the hub of the fast pulley, all danger of such an occurrence is avoided, for in case the shaft should stick on the sleeve the whole shaft would be rotated, and there would be no tendency to unscrew the stud.

While the above-described construction is particularly useful in the above-described relation, yet it may be used advantageously in other relations.

Having thus described my invention, what I claim as new, and desire to secure by Letters Patent, is—

1. In combination with an inner and an outer journal-box, a shaft journaled in, and having its outer end extend beyond the outer end of said inner box, a pulley fixed on the outer end of said shaft, a shaft extension rotatably mounted in said outer box and having a threaded connection with the end of said shaft and a pulley rotatably mounted on said extension between said fixed pulley and said outer box, substantially as described.

2. In combination with an inner and an outer journal-box, a shaft journaled in, and having its outer end extend beyond the outer end of

said inner box, a pulley fixed on the outer end of said shaft, a stud passing through said outer box and having a head at its outer end and a screw-thread at its inner end which engages a correspondingly-threaded bore in the end of the shaft, a sleeve fitted on said stud and journaled in said outer box, the outer end of said sleeve bearing against the head of said bolt and its inner end against the hub of said fixed pulley, substantially as described.

3. In combination with an inner and an outer journal-box, a shaft journaled in, and having its outer end extend beyond the outer end of said inner box, a pulley fixed on the outer end of said shaft, a stud passing through the outer box and having a threaded connection at its inner end with the outer end of the shaft, a sleeve on said bolt journaled in said outer box, and a loose pulley journaled on said sleeve between said outer bearing and the fixed pulley, substantially as described.

4. In combination with an inner and an outer journal-box, a shaft journaled in, and having its outer end extend beyond the outer end of said inner box, a pulley fixed on the outer end of said shaft, a stud passing through said outer box and having a head at its outer end and a screw-thread at its inner end which engages a correspondingly-threaded bore in the end of the shaft, a sleeve fitted on said stud and journaled in said outer box, and an interlocking connecting means between said sleeve and fixed pulley to prevent rotation of one with relation the other, substantially as described.

In testimony whereof I have signed my name to this specification in the presence of two subscribing witnesses.

THOMAS F. CUDDY.

Witnesses:

LOUIS H. HARRIMAN,
H. B. DAVIS.