



(19) **United States**

(12) **Patent Application Publication**  
**Hiner et al.**

(10) **Pub. No.: US 2010/0199492 A1**

(43) **Pub. Date: Aug. 12, 2010**

(54) **CONFORMAL SHIELDING EMPLOYING SEGMENT BUILDUP**

(22) Filed: **Apr. 23, 2010**

**Related U.S. Application Data**

(75) Inventors: **David J. Hiner**, Chandler, AZ (US); **Waite R. Warren, JR.**, Greensboro, NC (US); **Donald Joseph Leahy**, Kernersville, NC (US); **David Jandzinski**, Summerfield, NC (US); **Thomas Scott Morris**, Lewisville, NC (US); **David Halchin**, Summerfield, NC (US); **Milind Shah**, San Diego, CA (US); **Mark Charles Held**, High Point, NC (US); **Brian Howard Calhoun**, Oak Ridge, NC (US); **Brian D. Sawyer**, Carrboro, NC (US); **Ulrik Riis Madsen**, Herning (DK)

(63) Continuation of application No. 11/952,545, filed on Dec. 7, 2007, now abandoned.

(60) Provisional application No. 60/946,453, filed on Jun. 27, 2007, provisional application No. 60/978,006, filed on Oct. 5, 2007.

**Publication Classification**

(51) **Int. Cl.**  
**H05K 3/00** (2006.01)  
(52) **U.S. Cl.** ..... **29/846**

(57) **ABSTRACT**

A meta-module having circuitry for two or more modules is formed on a substrate, which is preferably a laminated substrate. The circuitry for the different modules is initially formed on the single meta-module. Each module will have one or more component areas in which the circuitry is formed. A metallic structure is formed on or in the substrate for each component area to be shielded. A single body, such as an overmold body, is then formed over all of the modules on the meta-module. At least a portion of the metallic structure for each component area to be shielded is then exposed through the body by a cutting, drilling, or like operation. Next, an electromagnetic shield material is applied to the exterior surface of the body of each of the component areas to be shielded and in contact with the exposed portion of the metallic structures.

Correspondence Address:  
**WITHROW & TERRANOVA, P.L.L.C.**  
**100 REGENCY FOREST DRIVE, SUITE 160**  
**CARY, NC 27518 (US)**

(73) Assignee: **RF MICRO DEVICES, INC.**,  
Greensboro, NC (US)

(21) Appl. No.: **12/766,347**

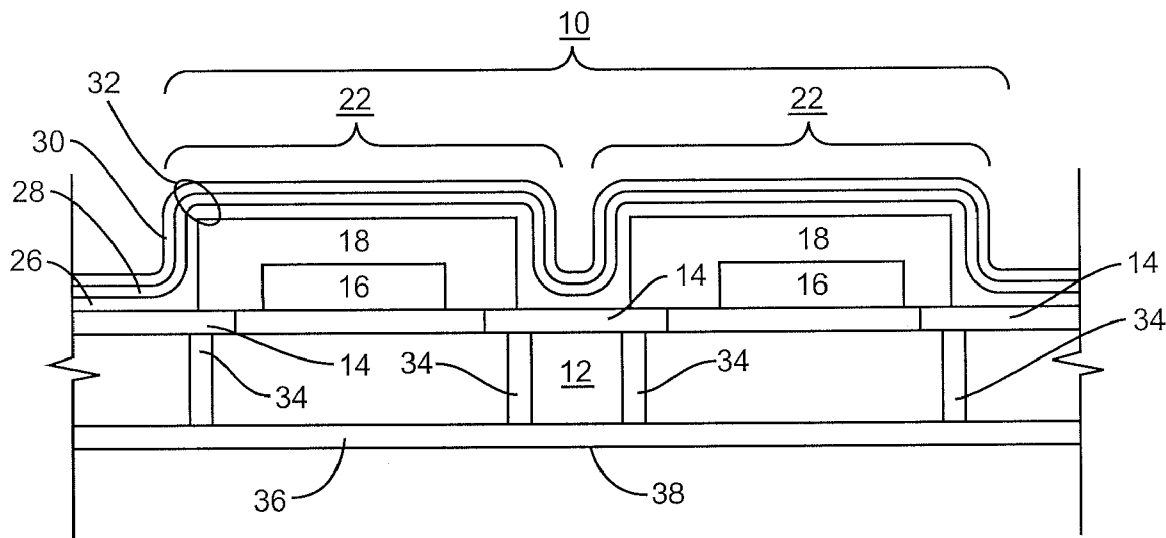

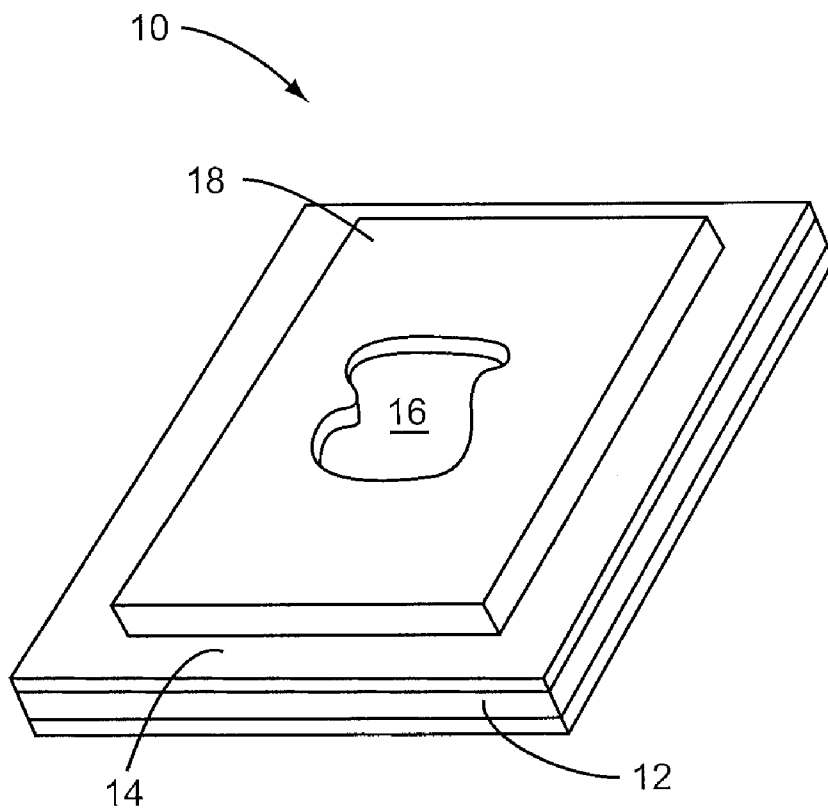

FIG. 1A

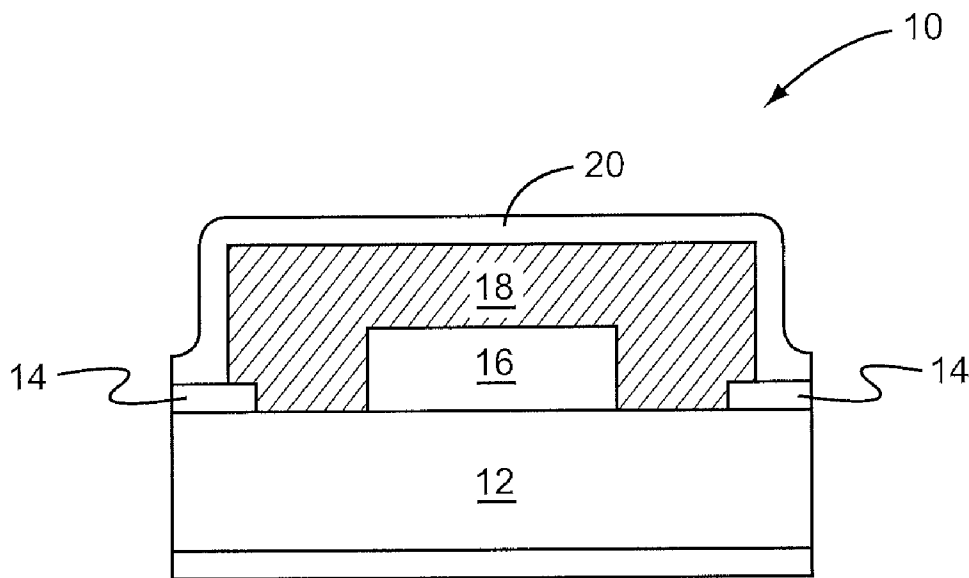

FIG. 1B

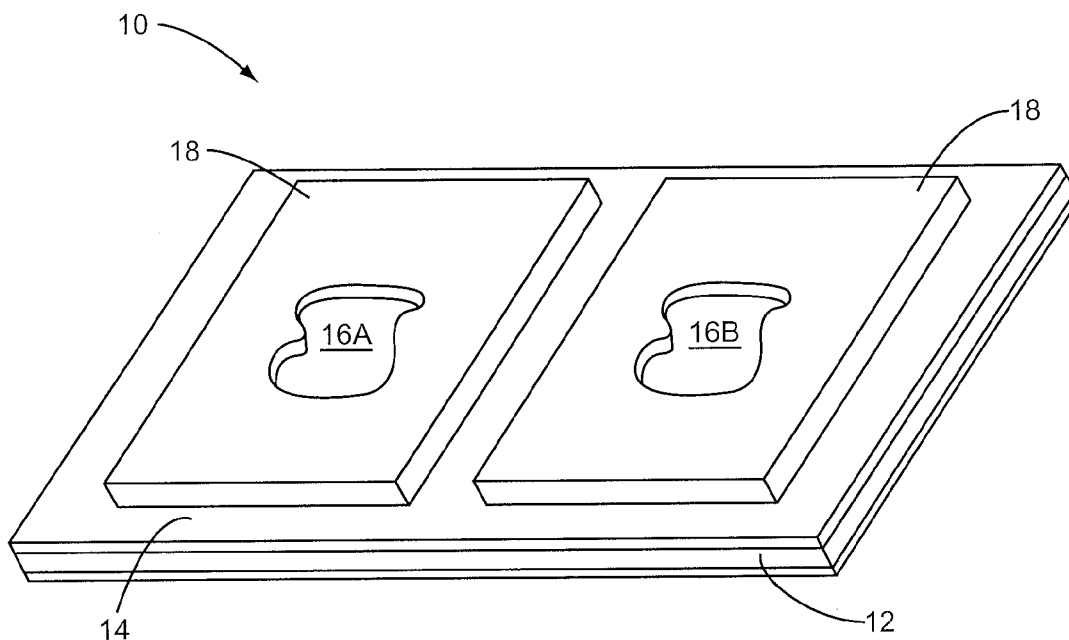

FIG. 2A

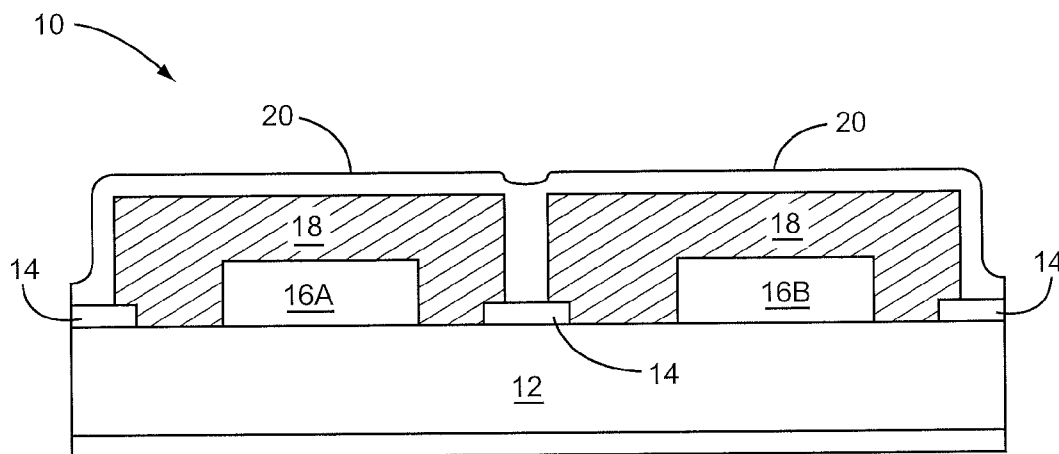

FIG. 2B

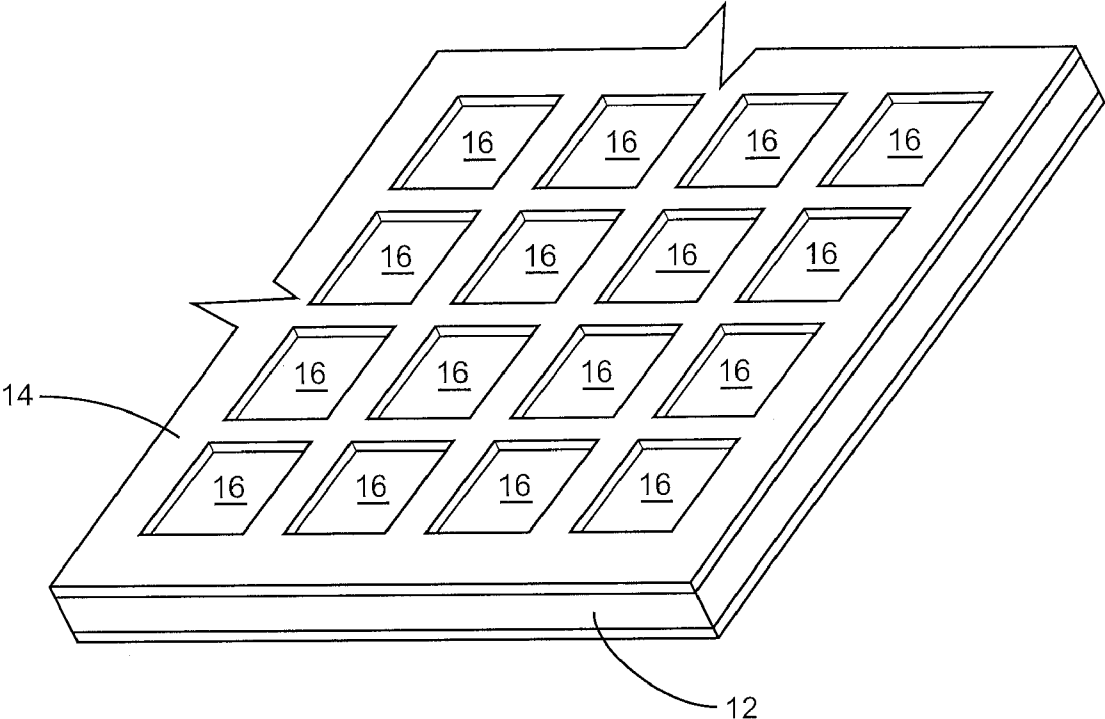

FIG. 3A

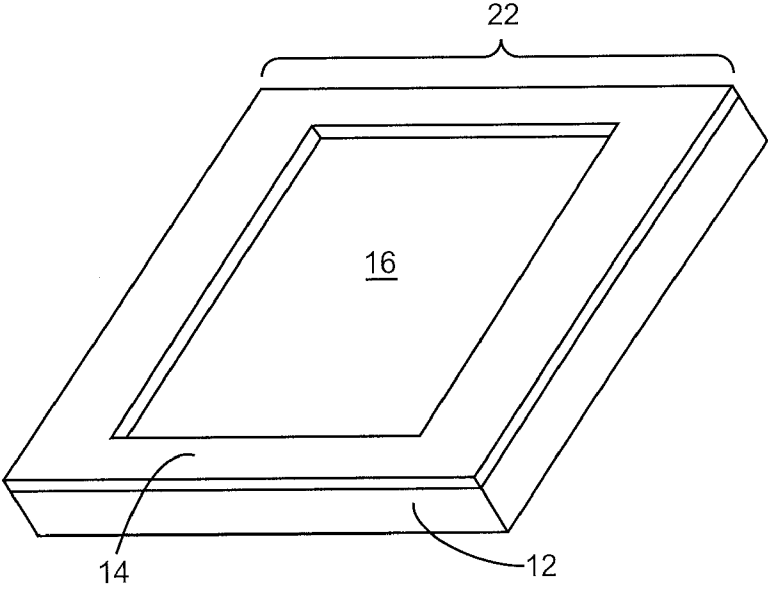

FIG. 3B

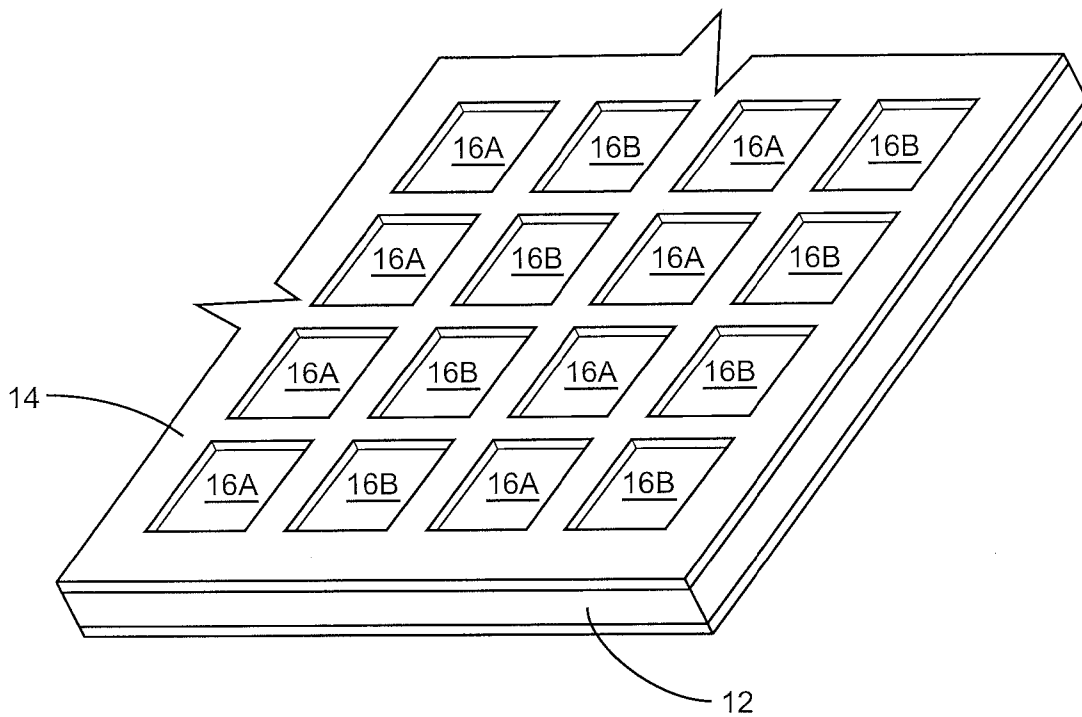

FIG. 4A

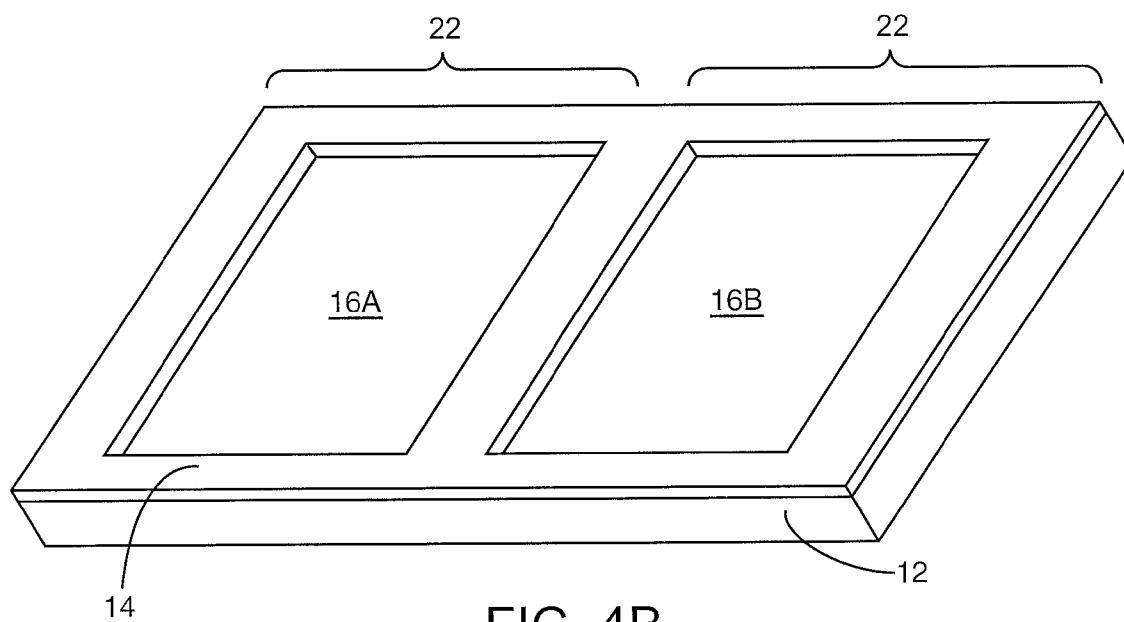

FIG. 4B

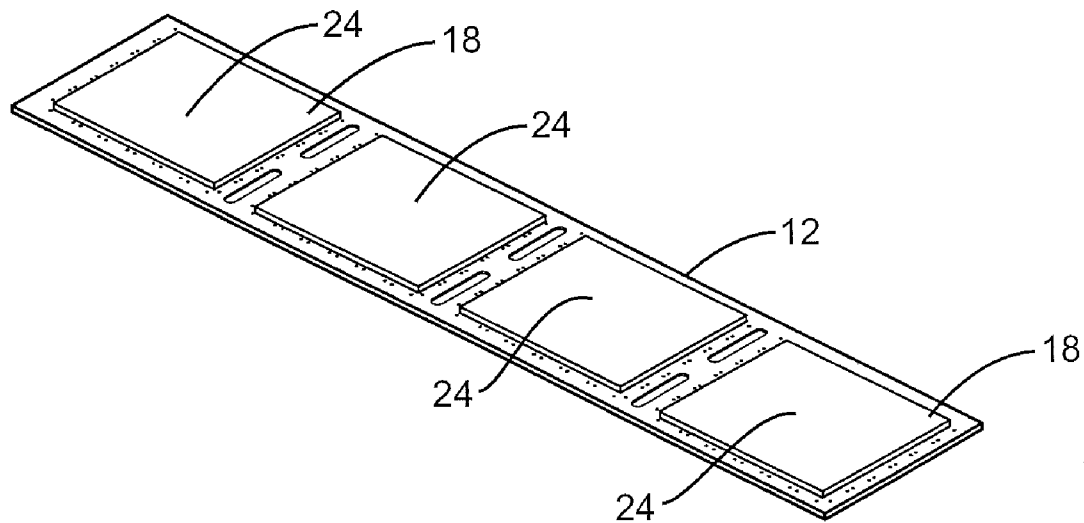

FIG. 5

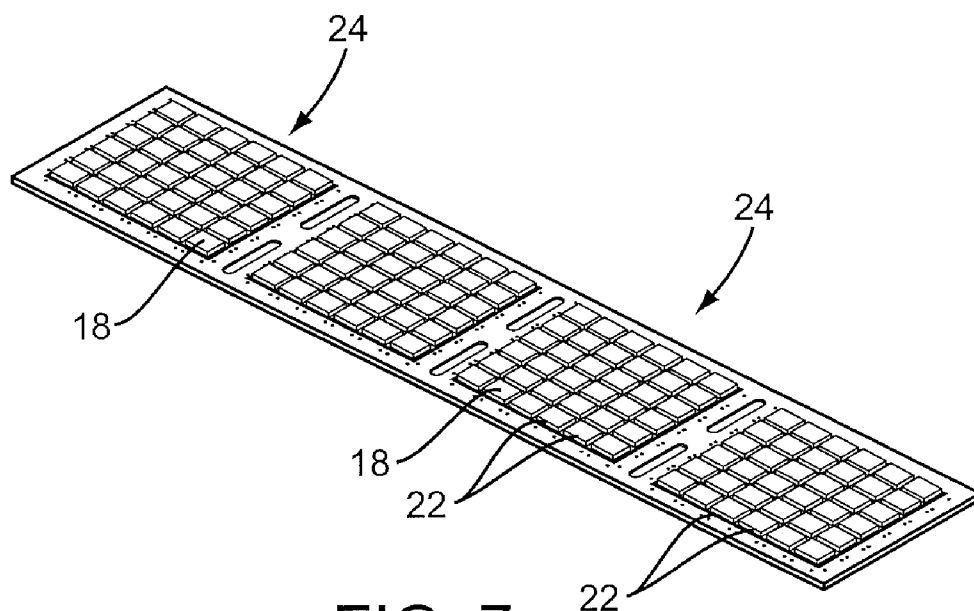

FIG. 7

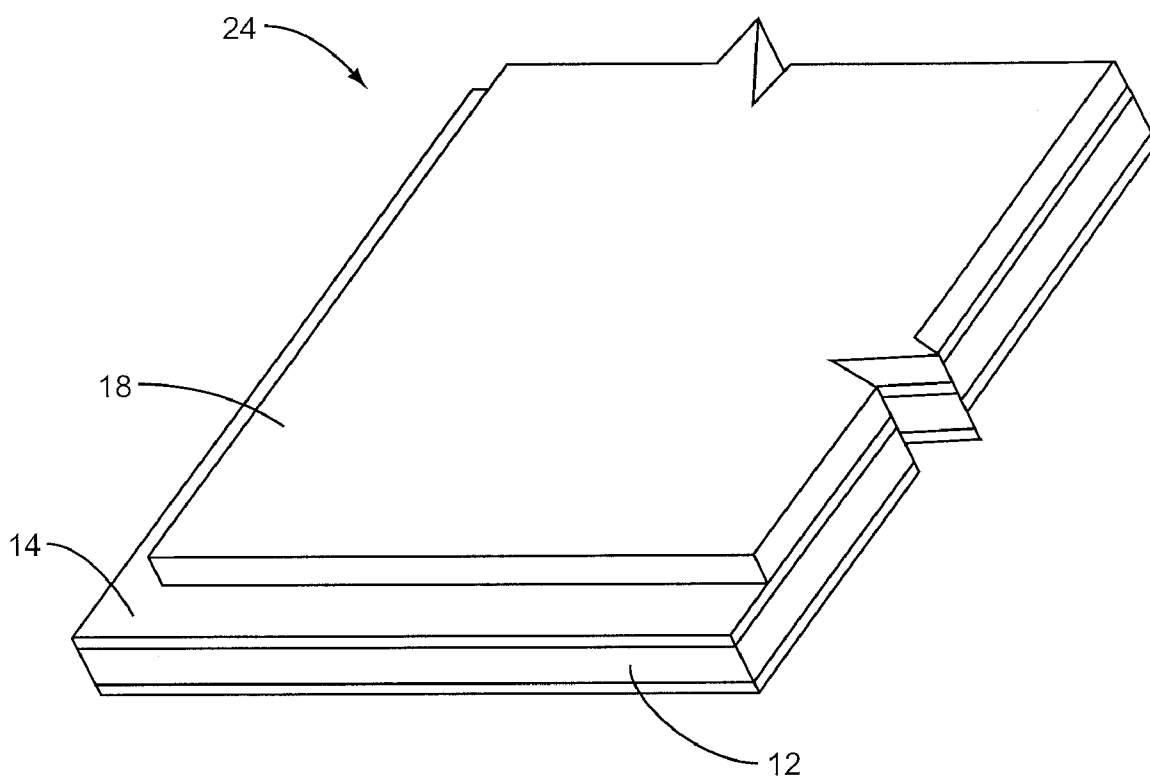

FIG. 6

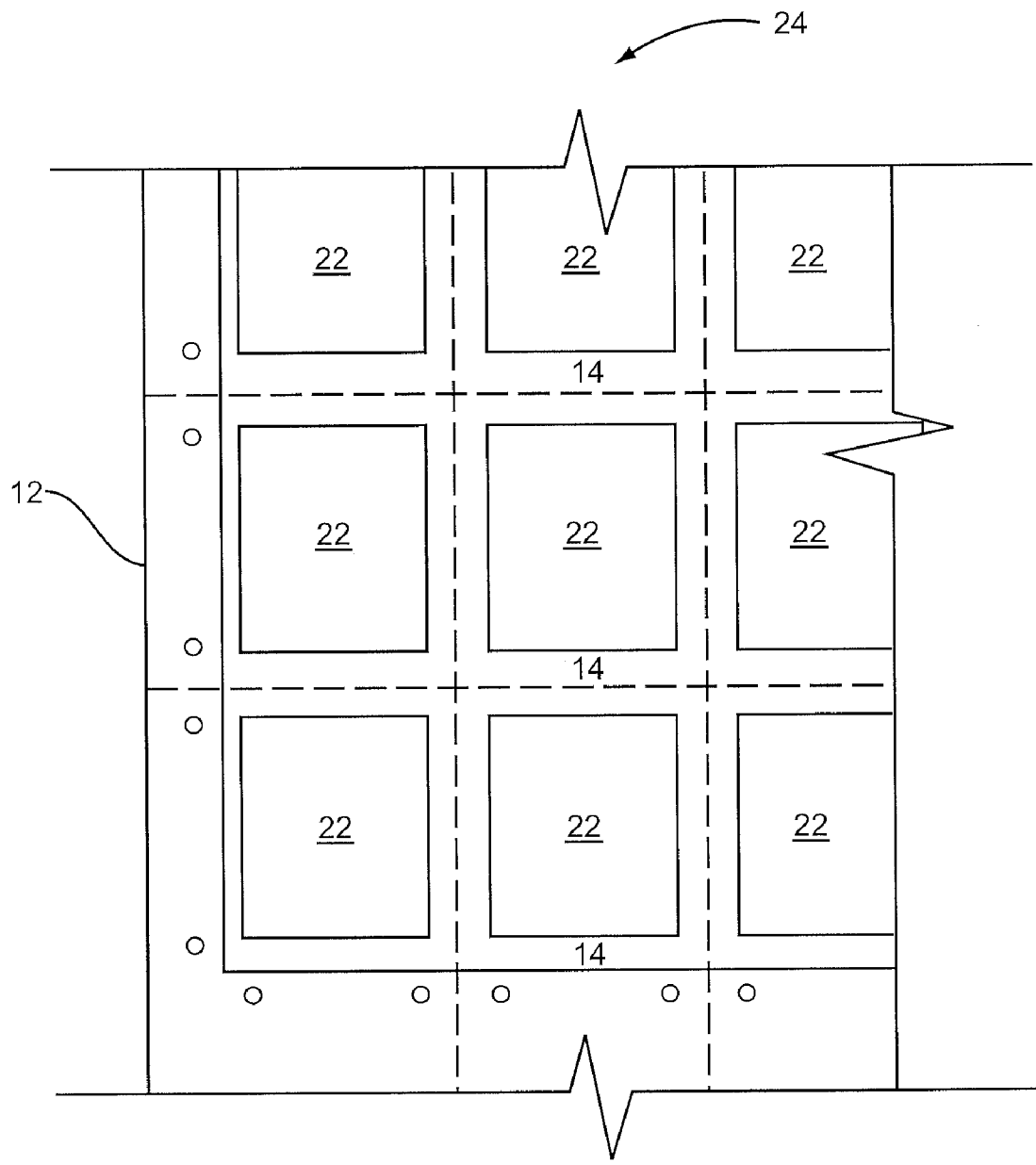

FIG. 8A



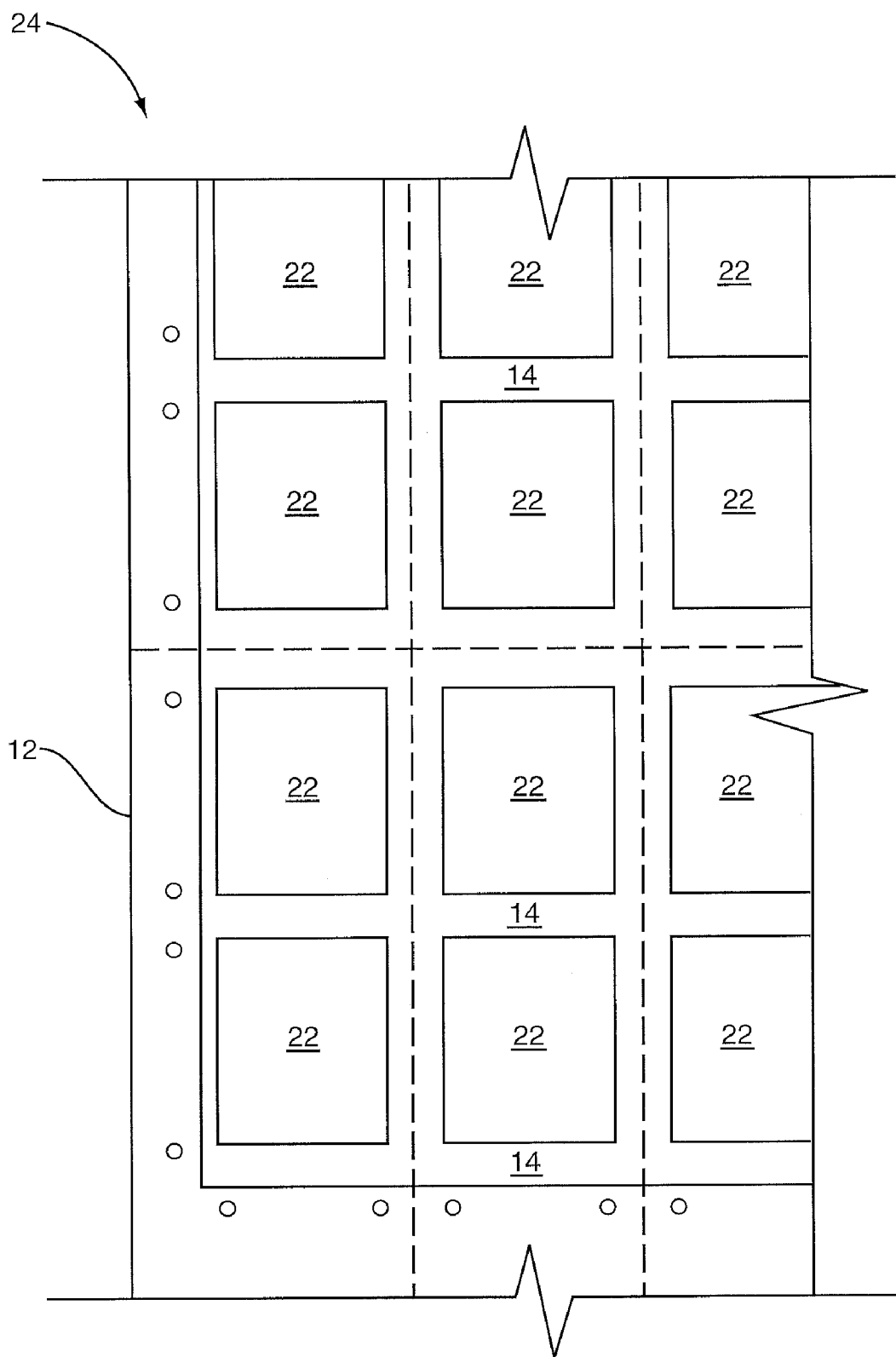

FIG. 8B

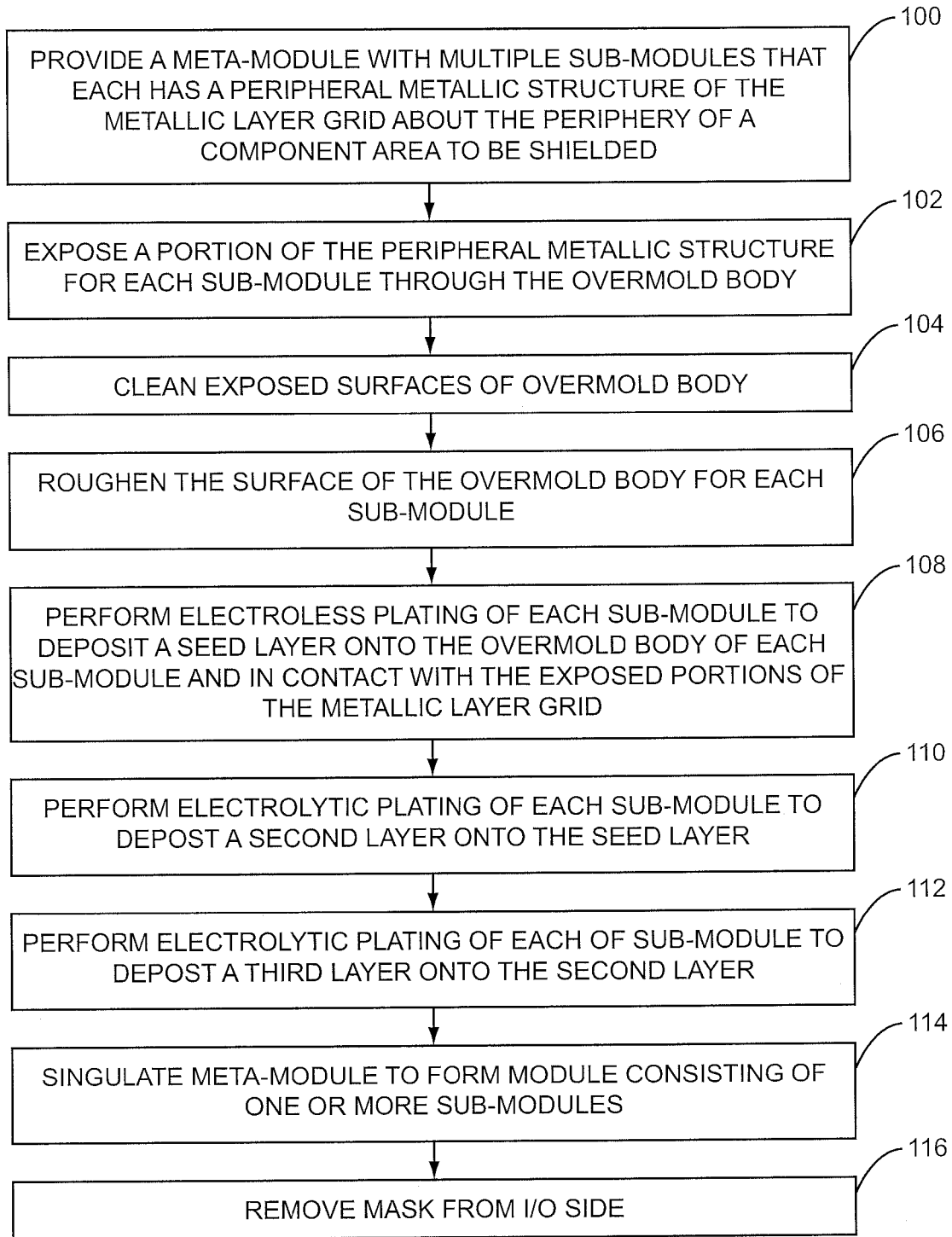

FIG. 9

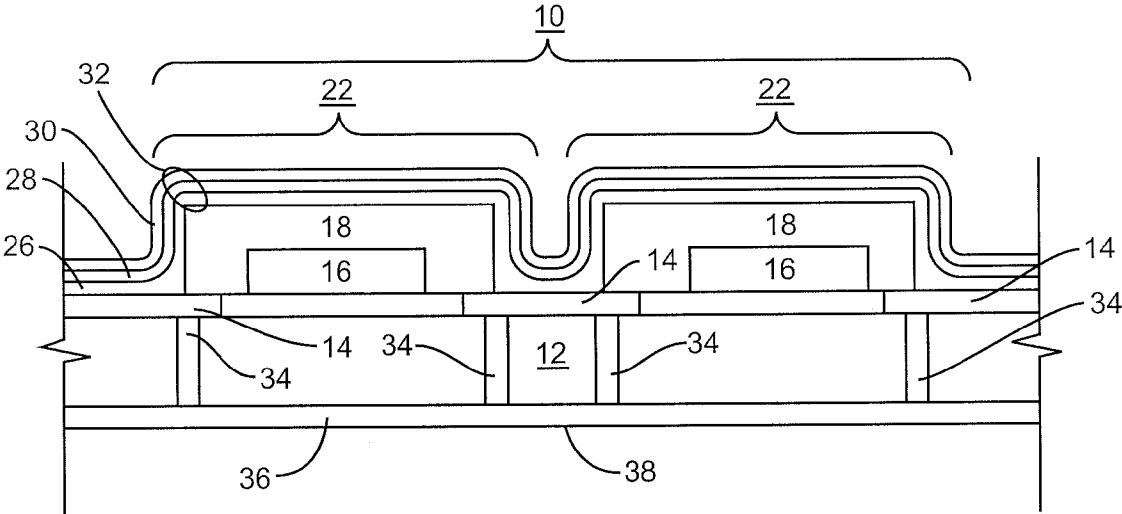

FIG. 10

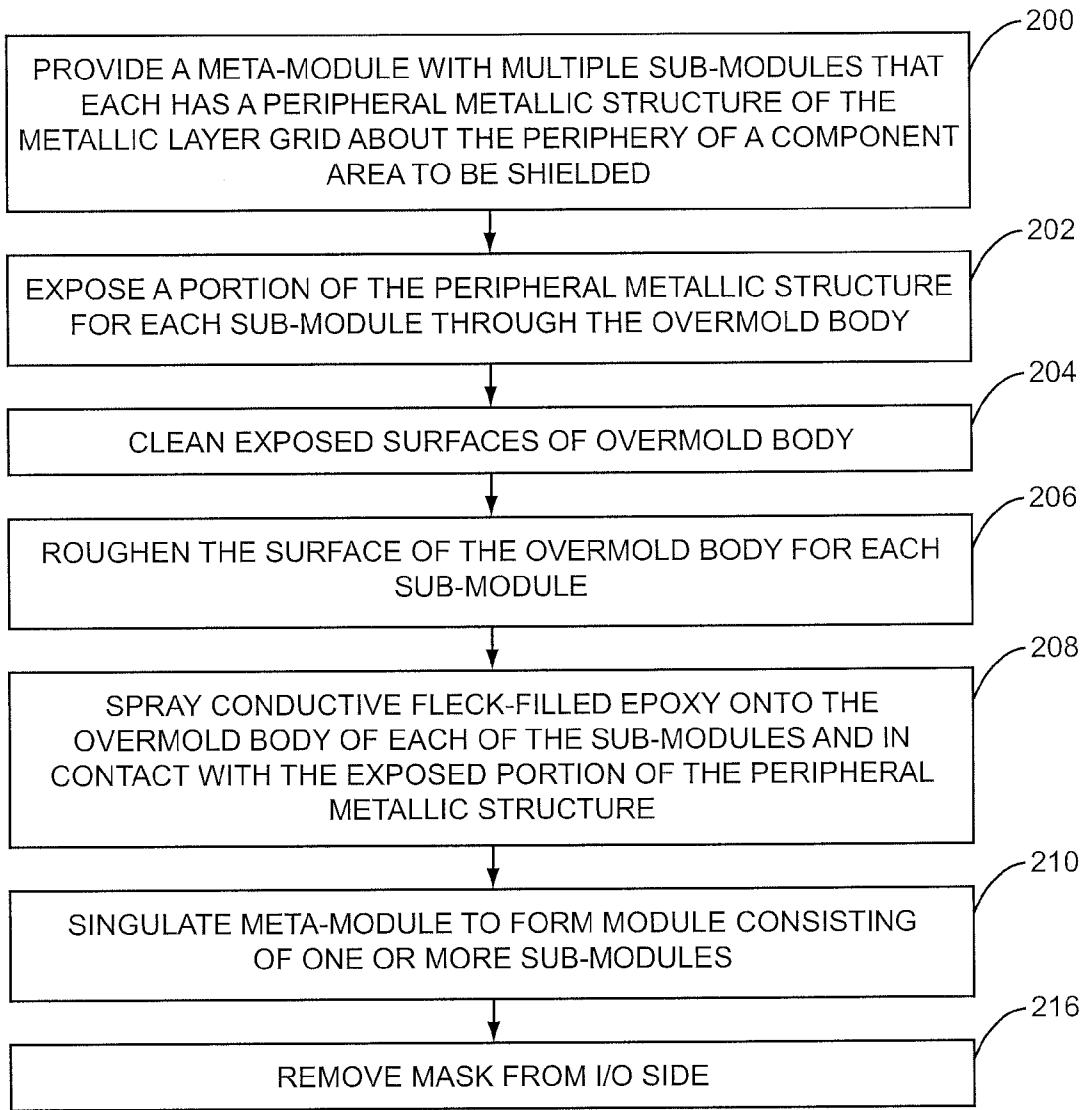

FIG. 11

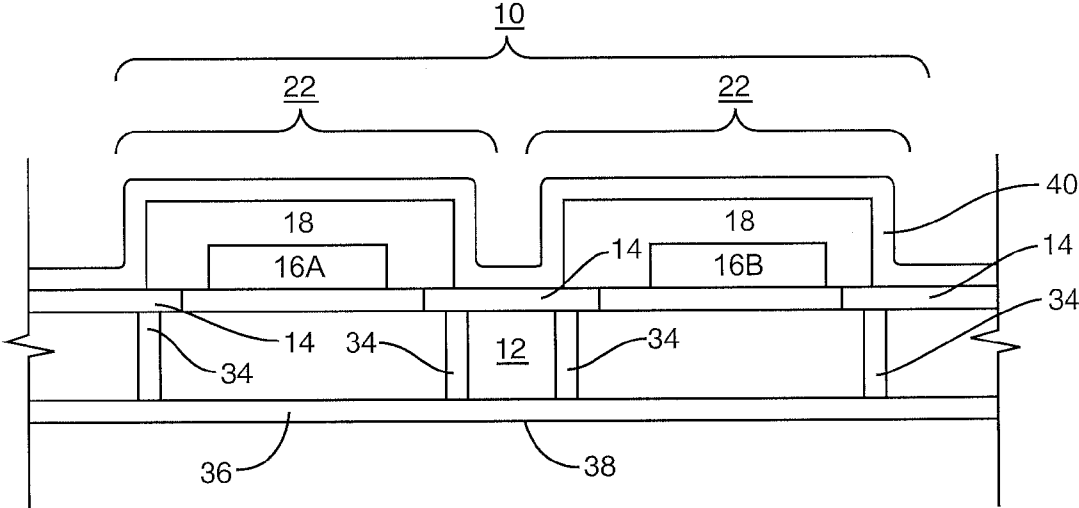

FIG. 12

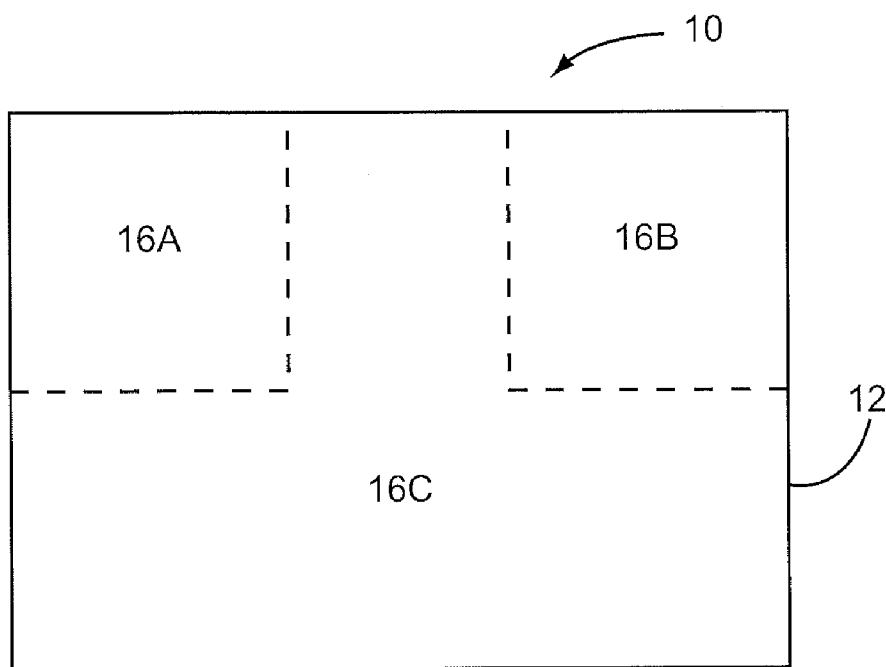

FIG. 13A

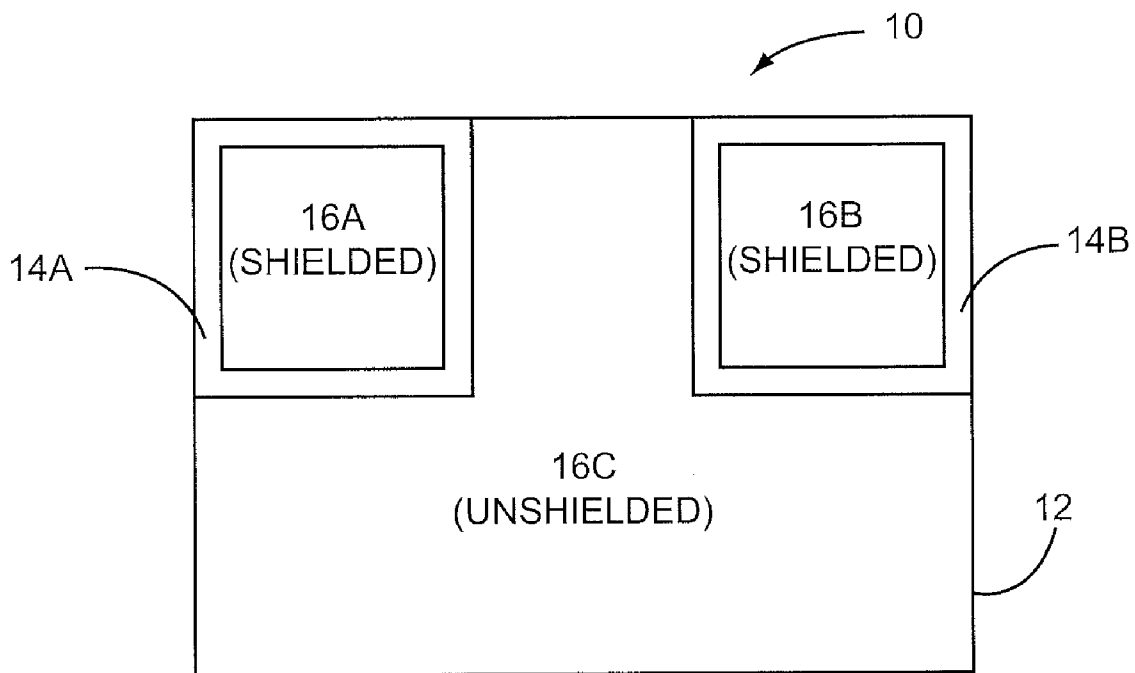

FIG. 13B

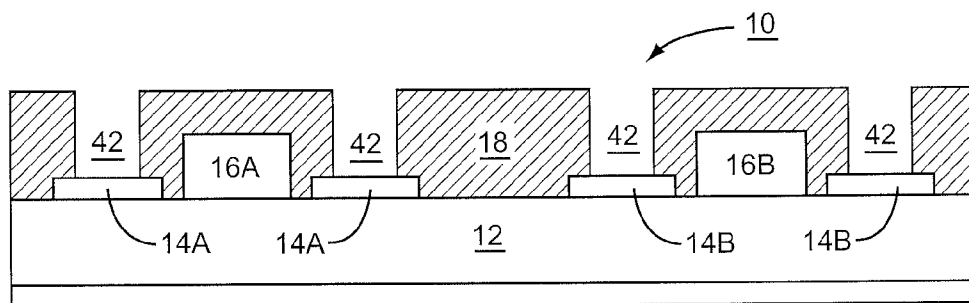

FIG. 14A

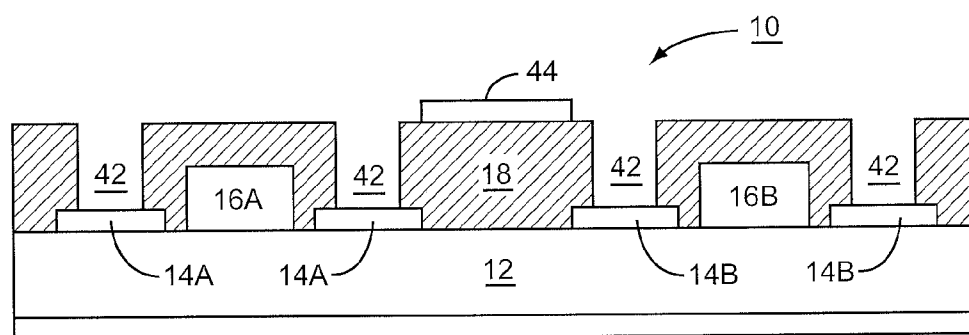

FIG. 14B

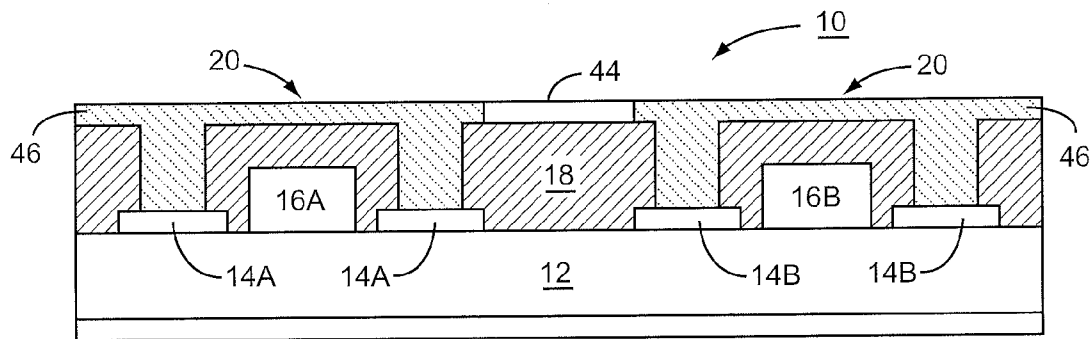

FIG. 14C

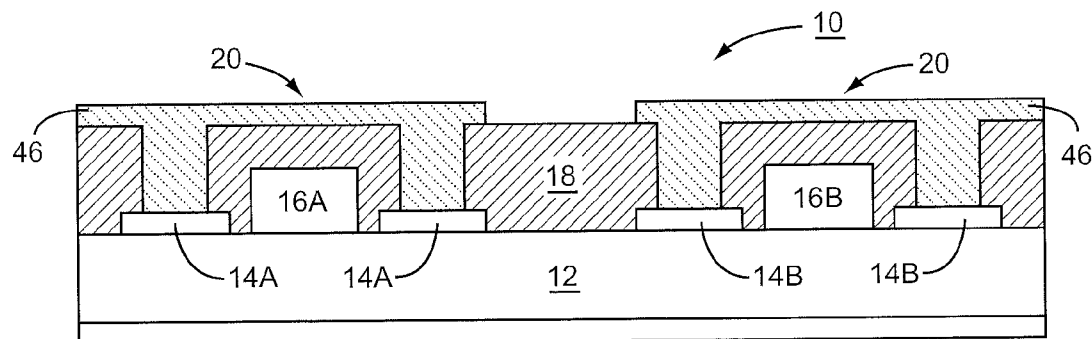

FIG. 14D

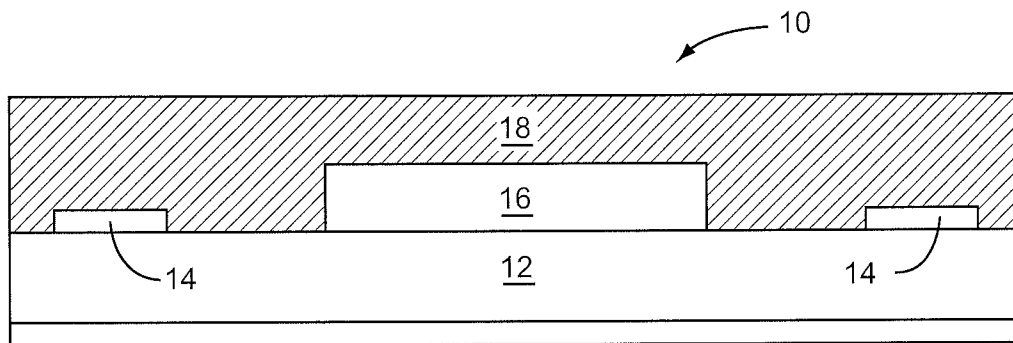

FIG. 15A

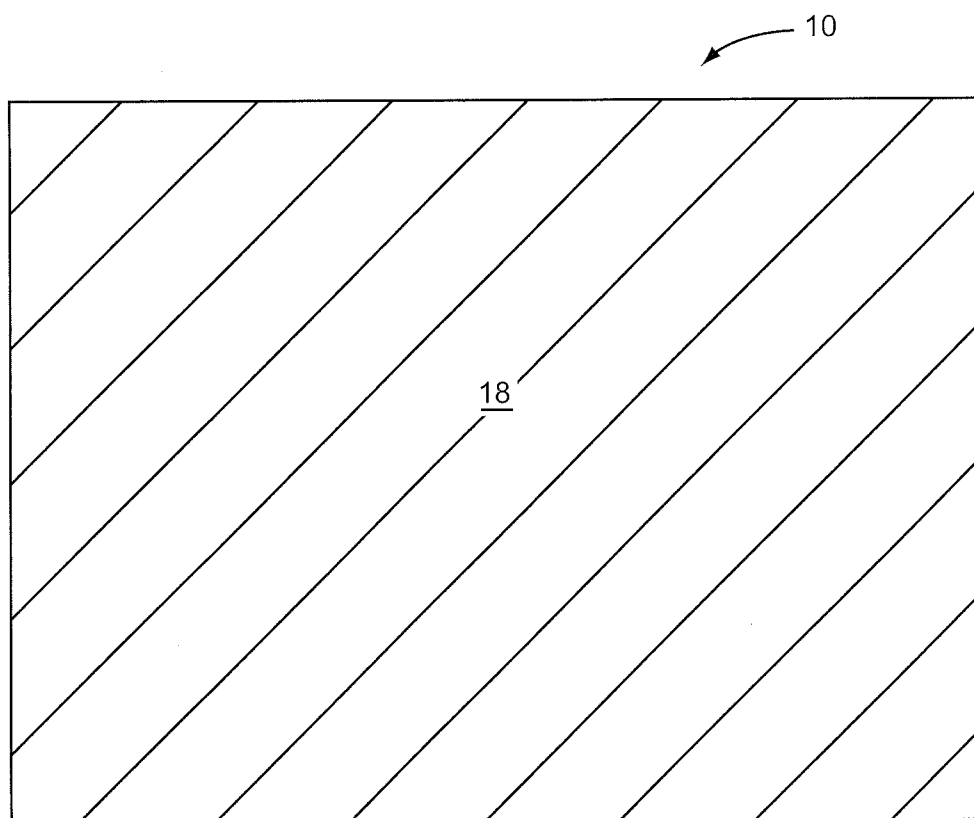

FIG. 15B



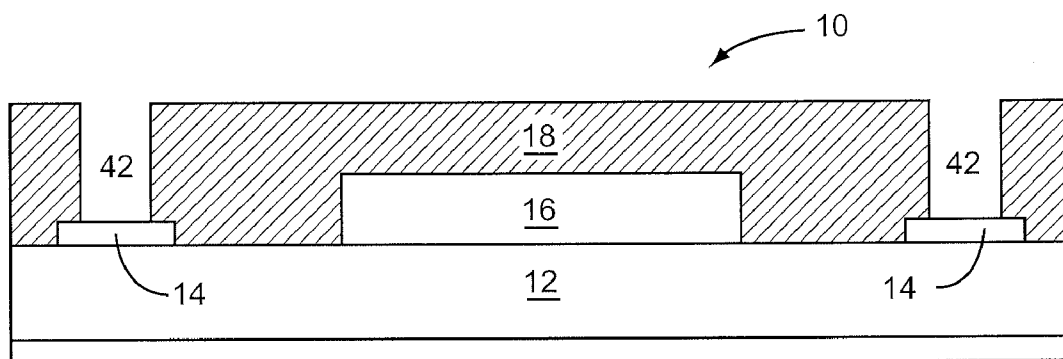

FIG. 15C

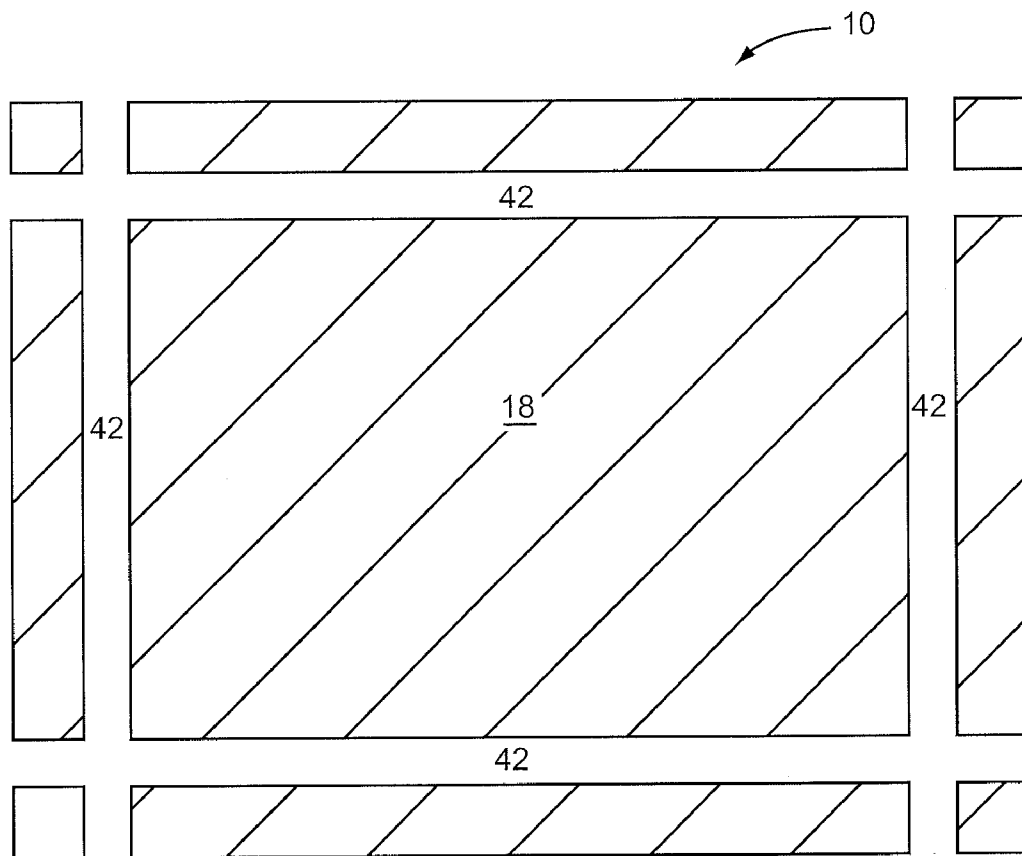

FIG. 15D

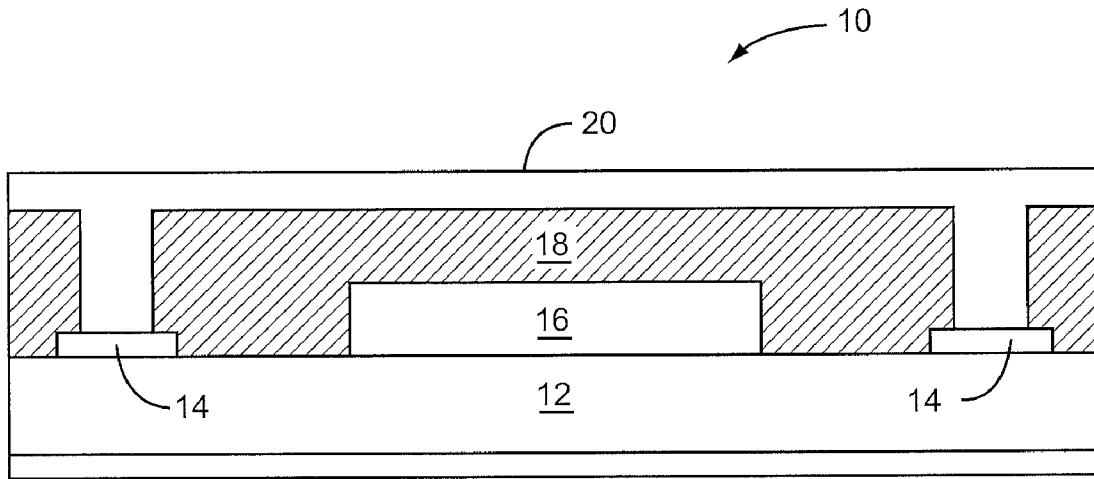

FIG. 15E

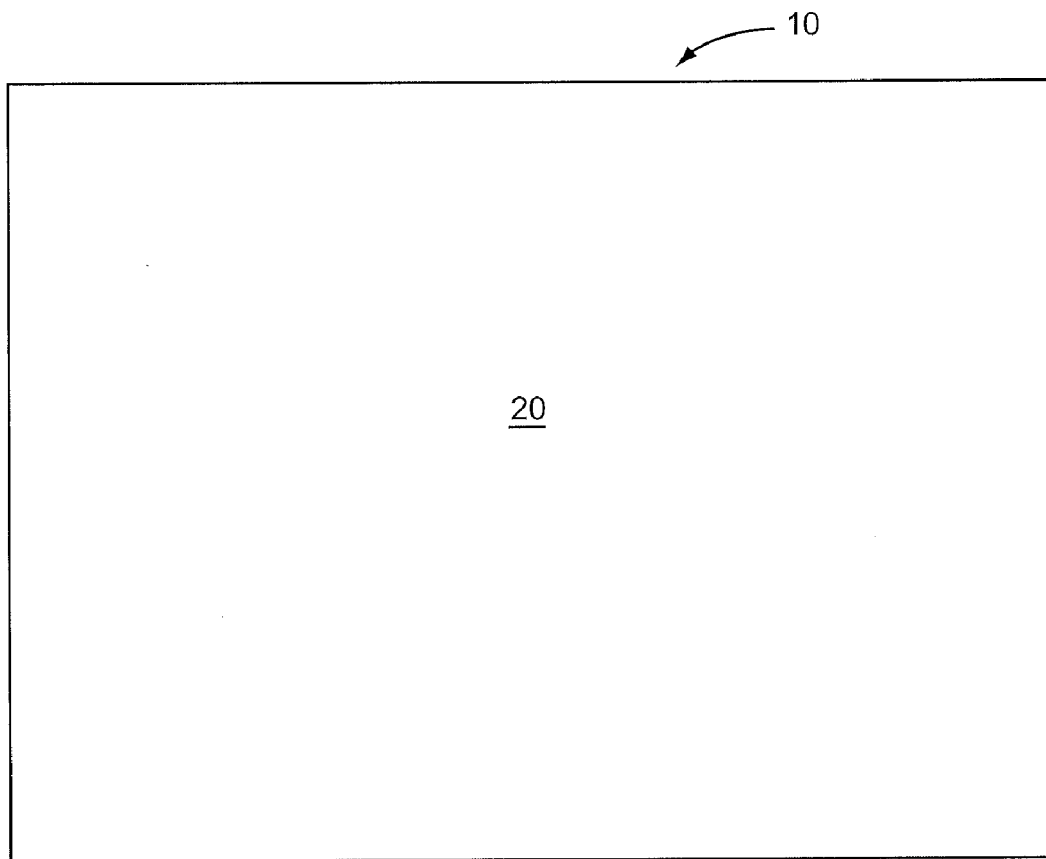

FIG. 15F

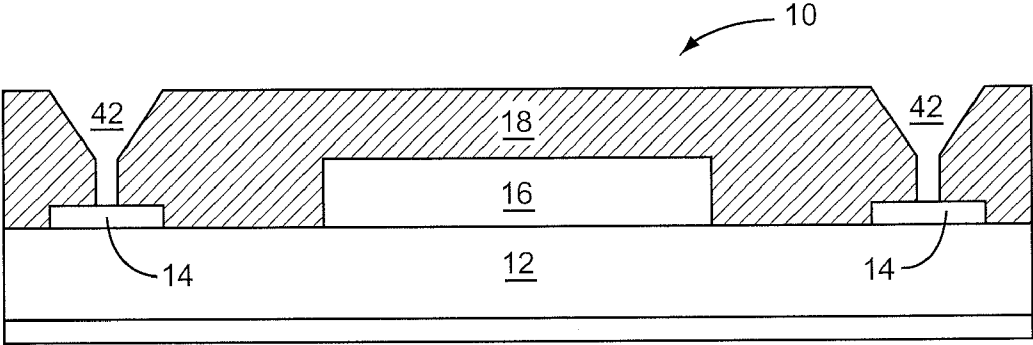

FIG. 16A

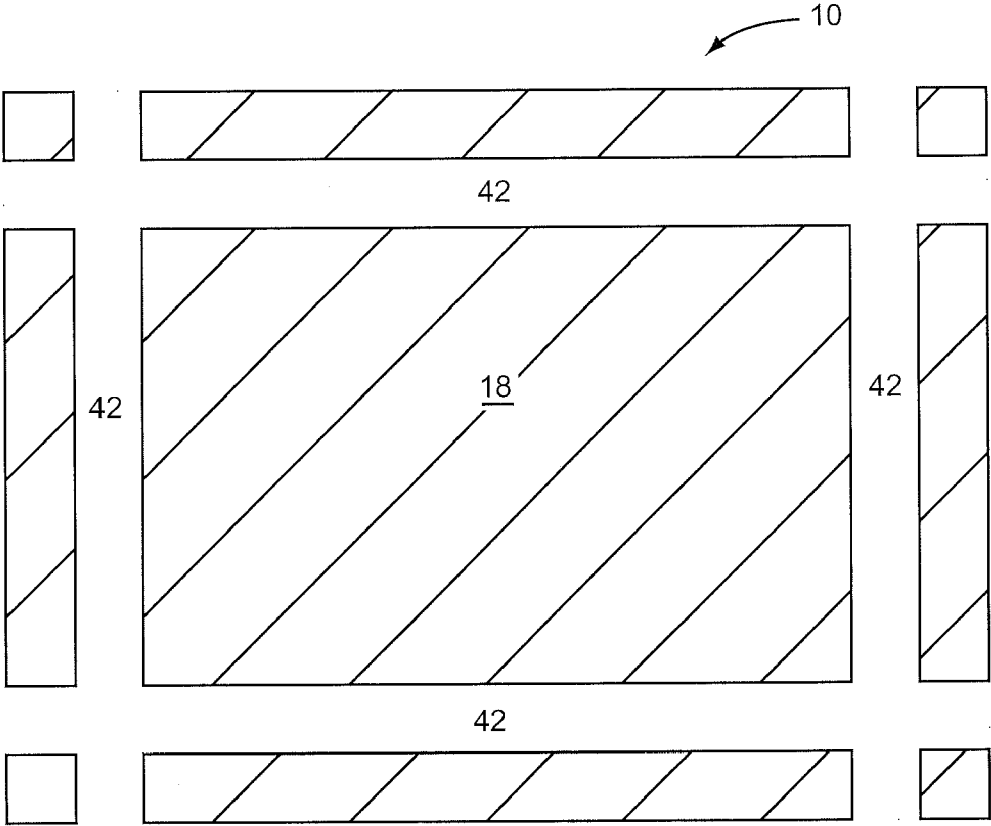

FIG. 16B

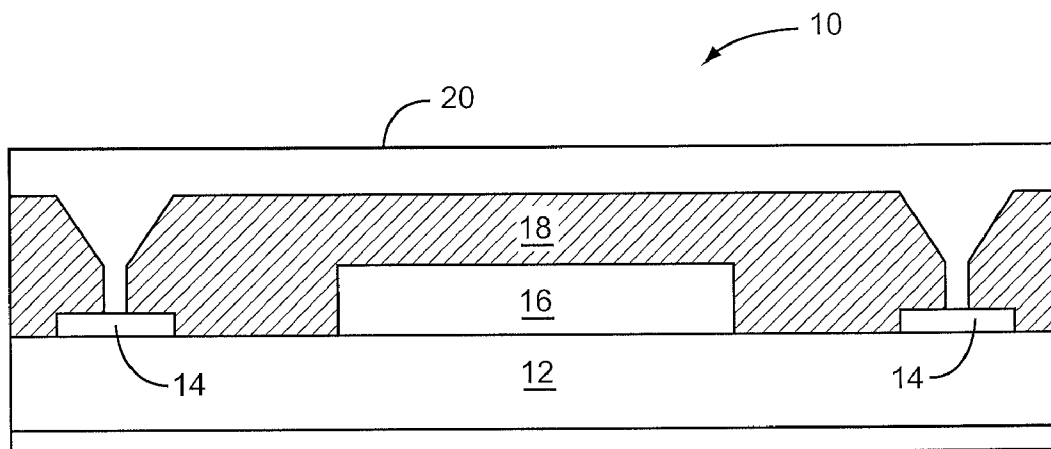

FIG. 16C

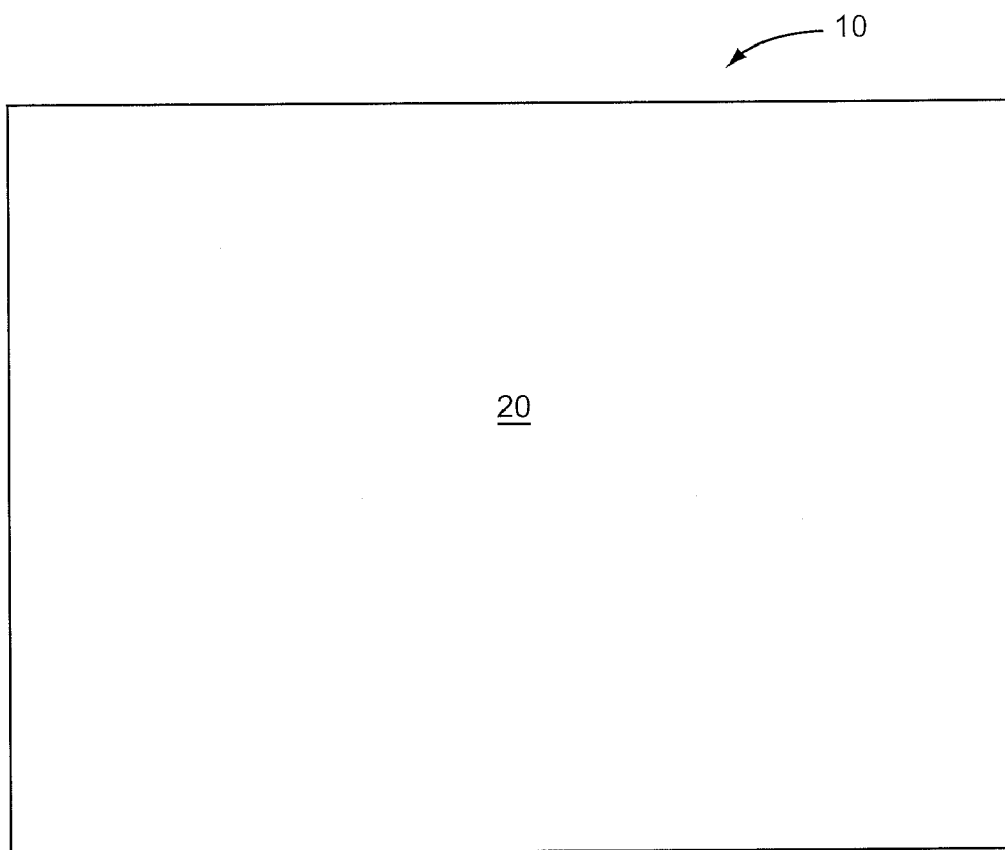

FIG. 16D

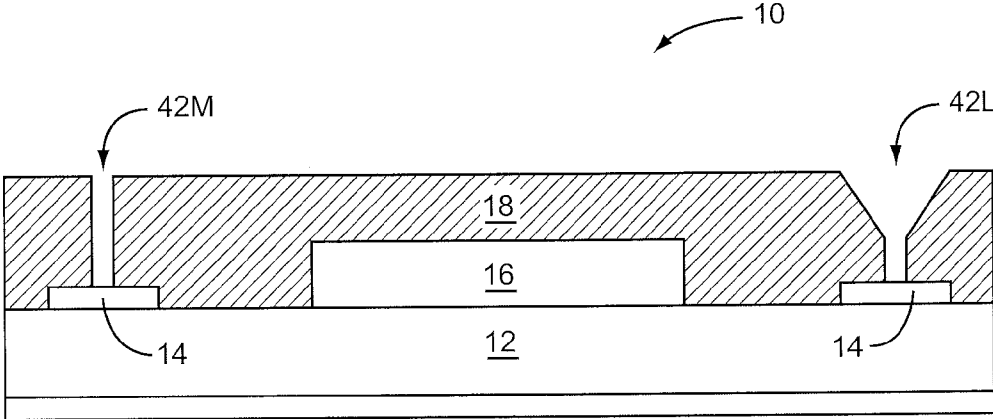

FIG. 17A

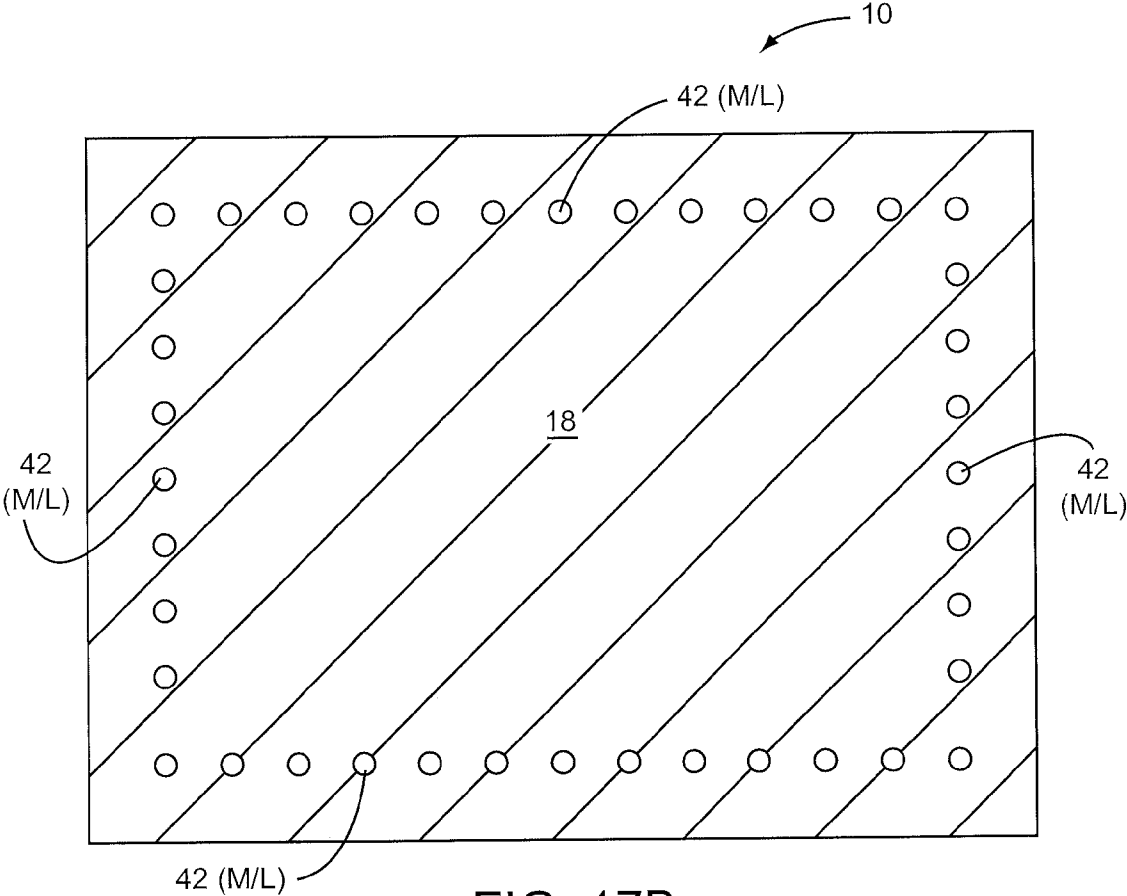

FIG. 17B

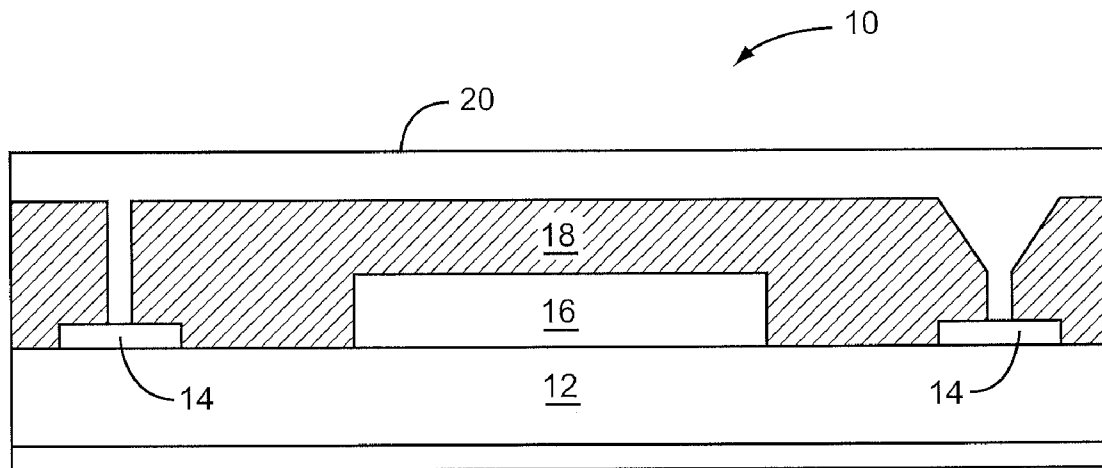

FIG. 17C

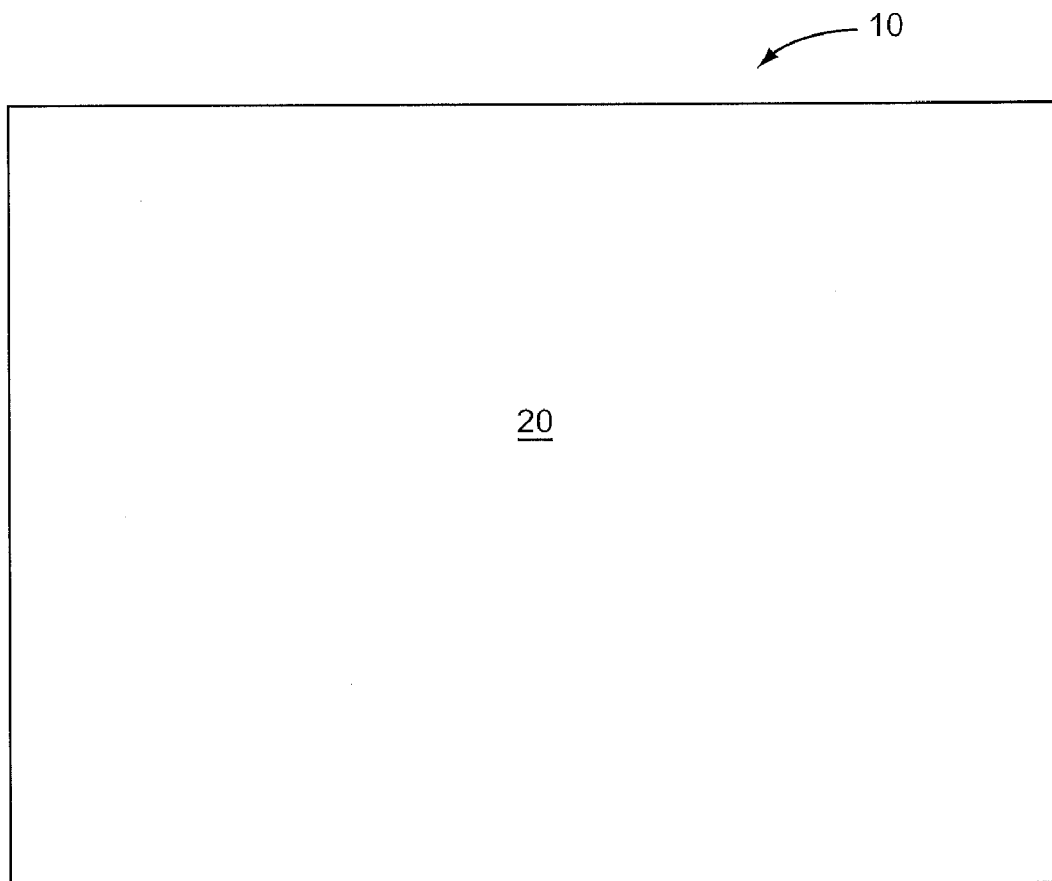

FIG. 17D

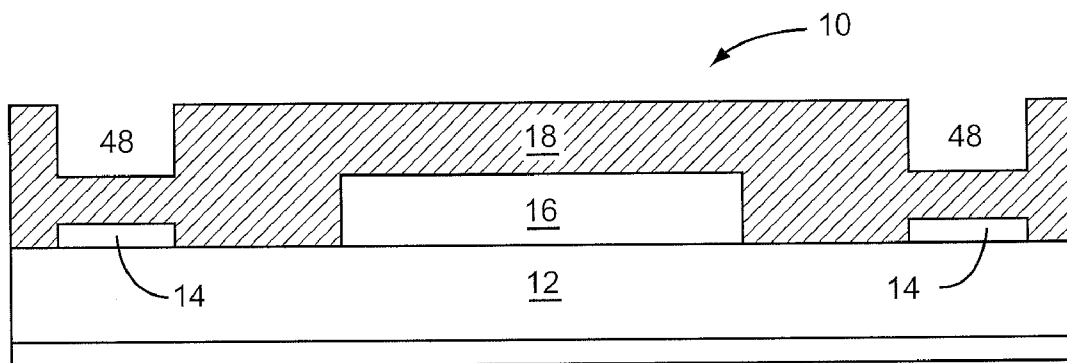

FIG. 18A

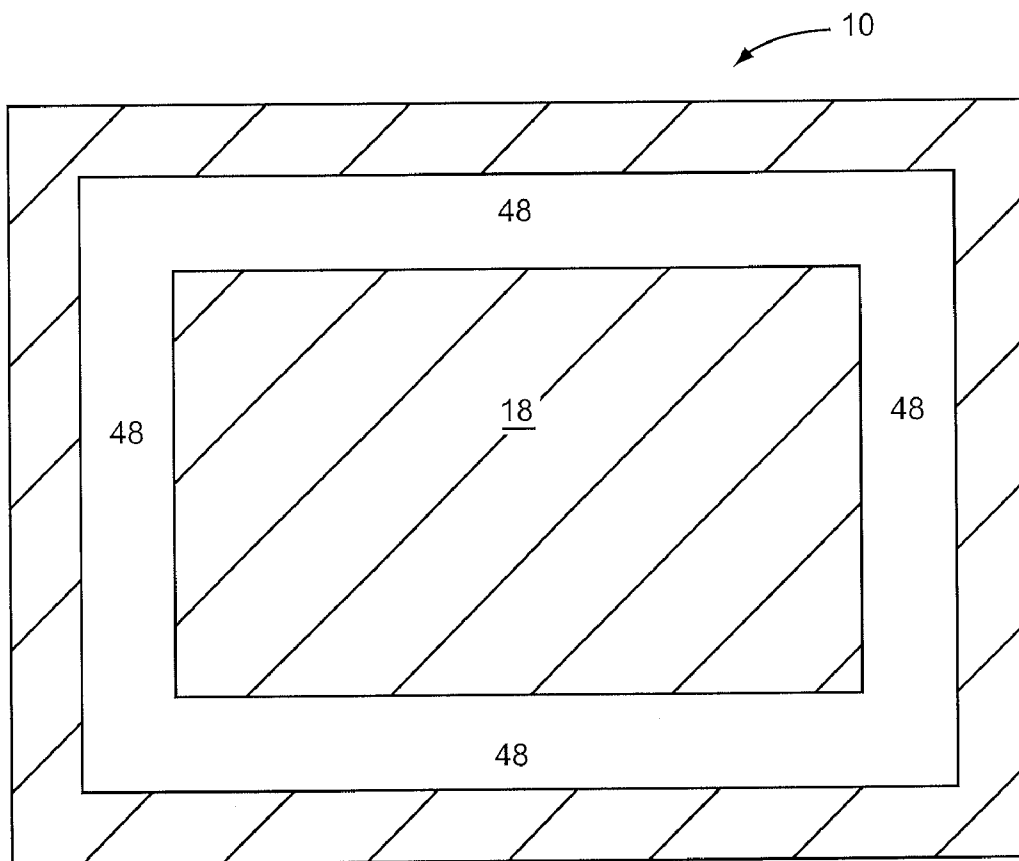

FIG. 18B

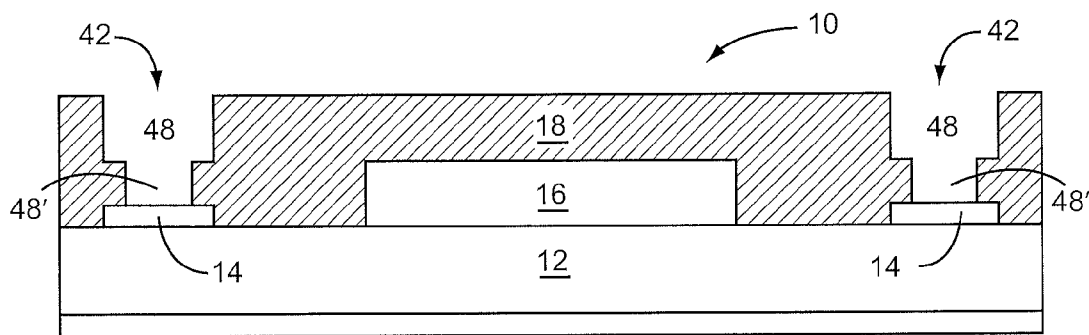

FIG. 18C

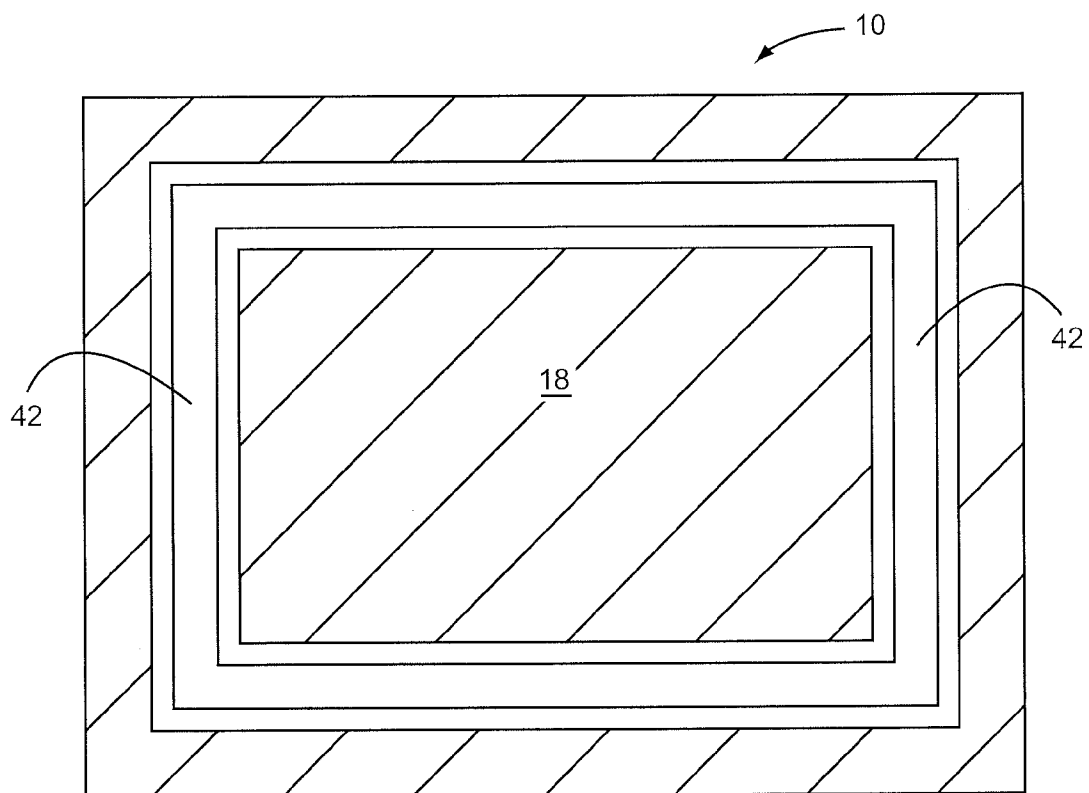

FIG. 18D



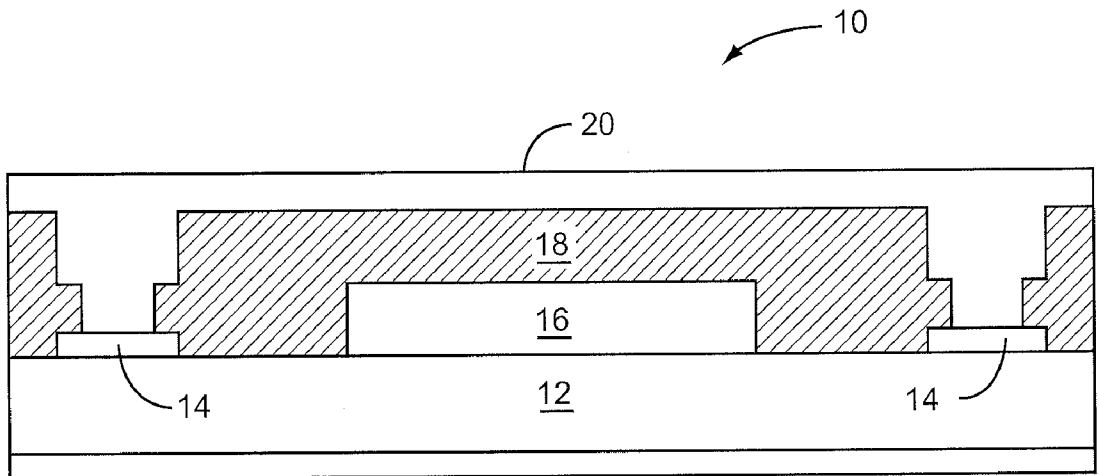

FIG. 18E

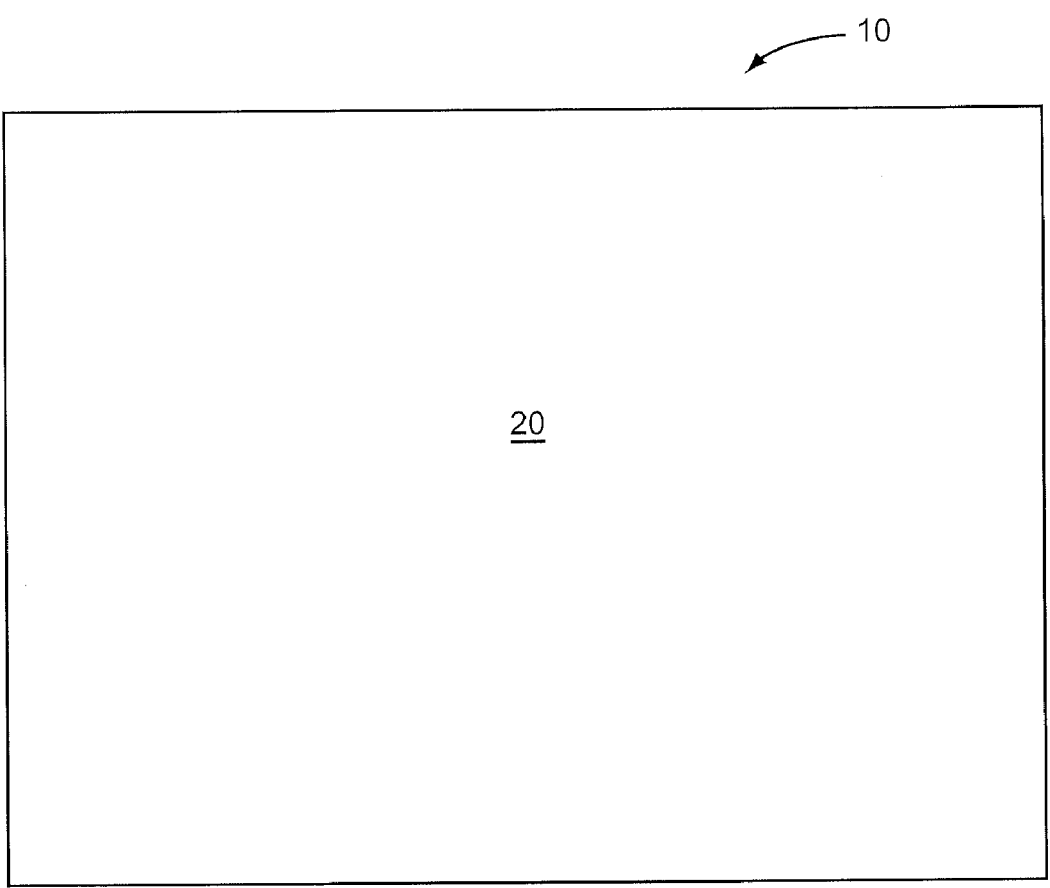

FIG. 18F

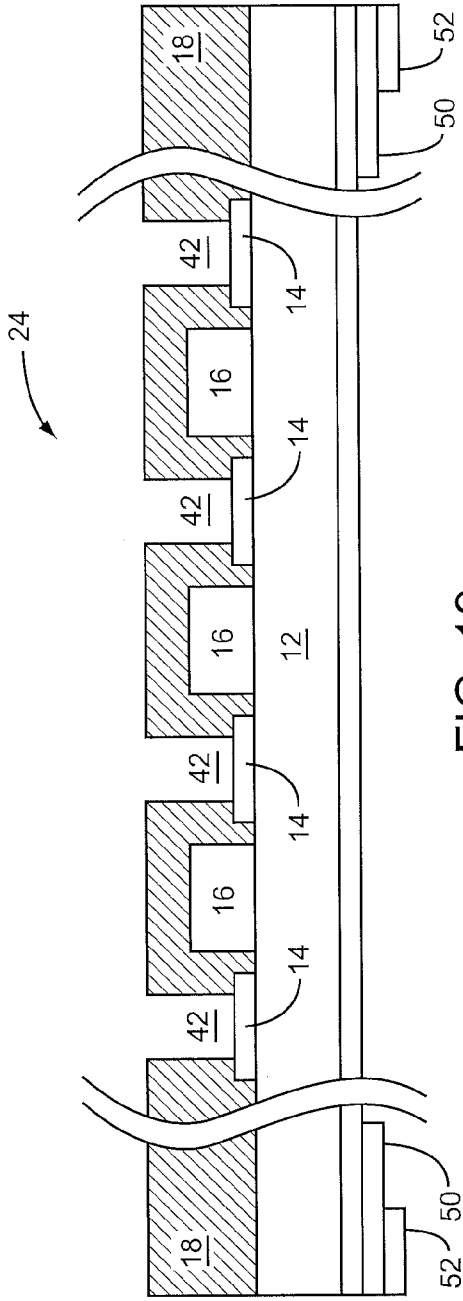

FIG. 19

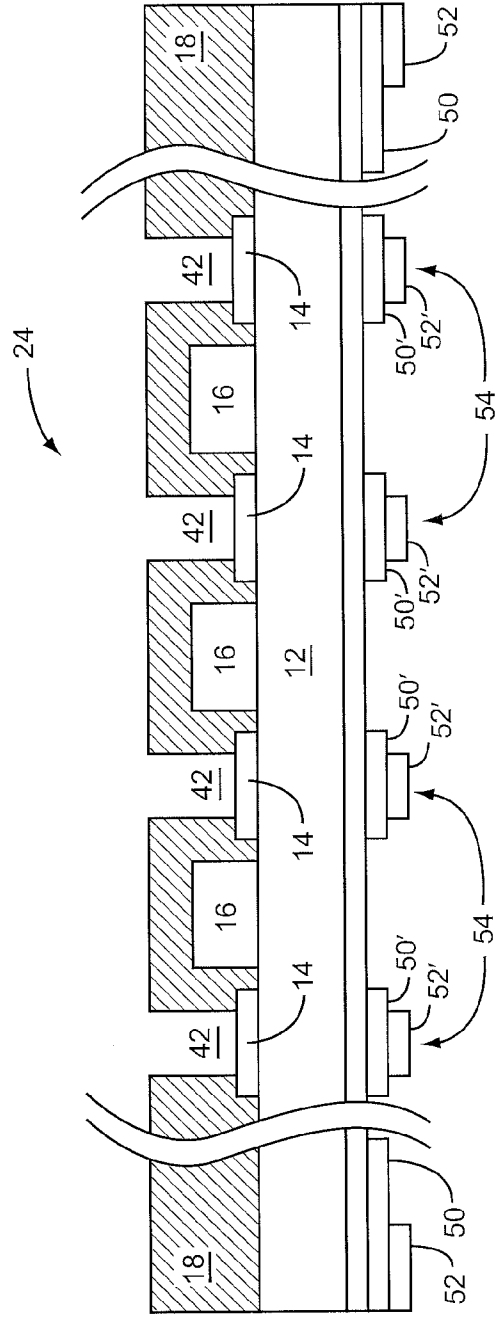

FIG. 20

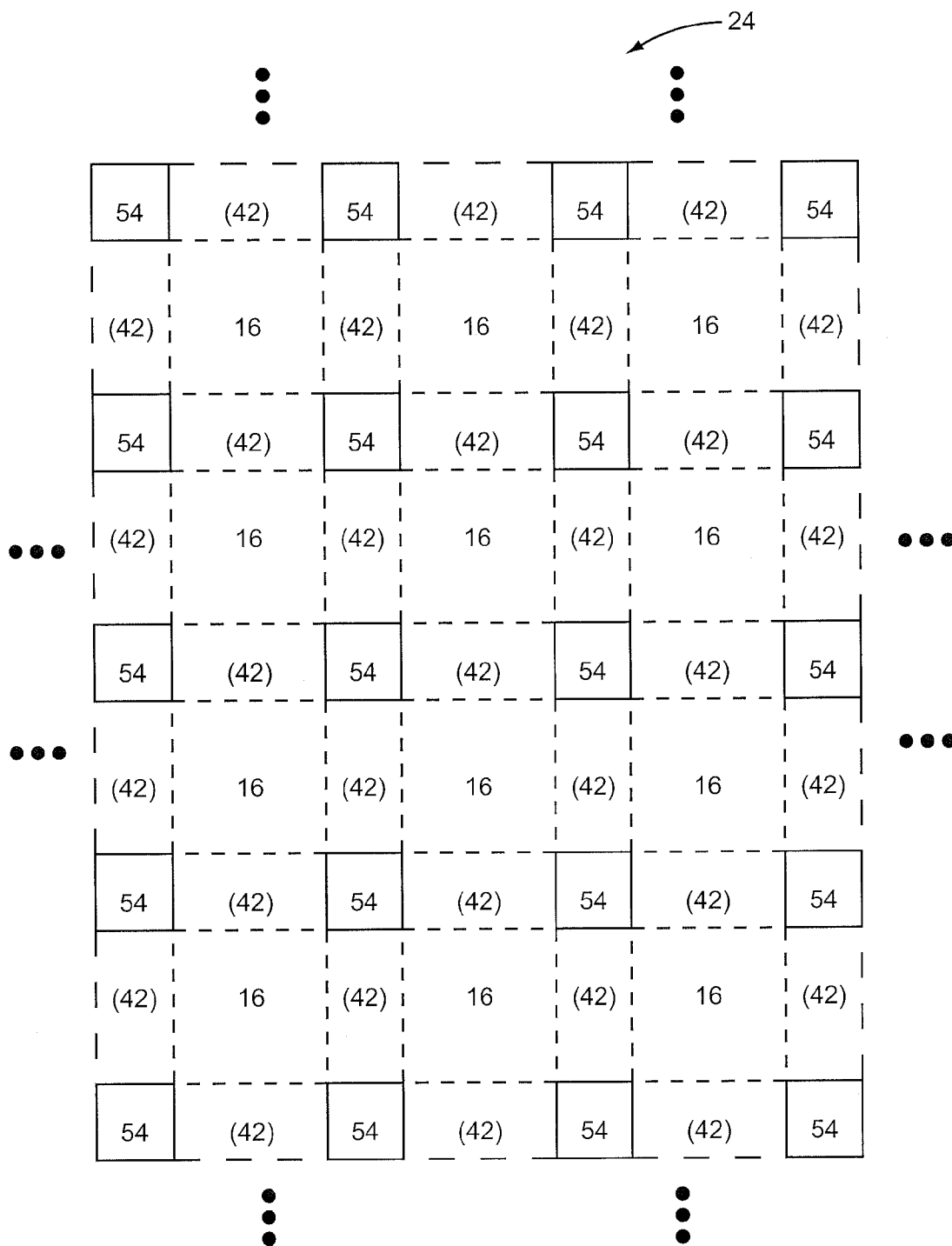

FIG. 21

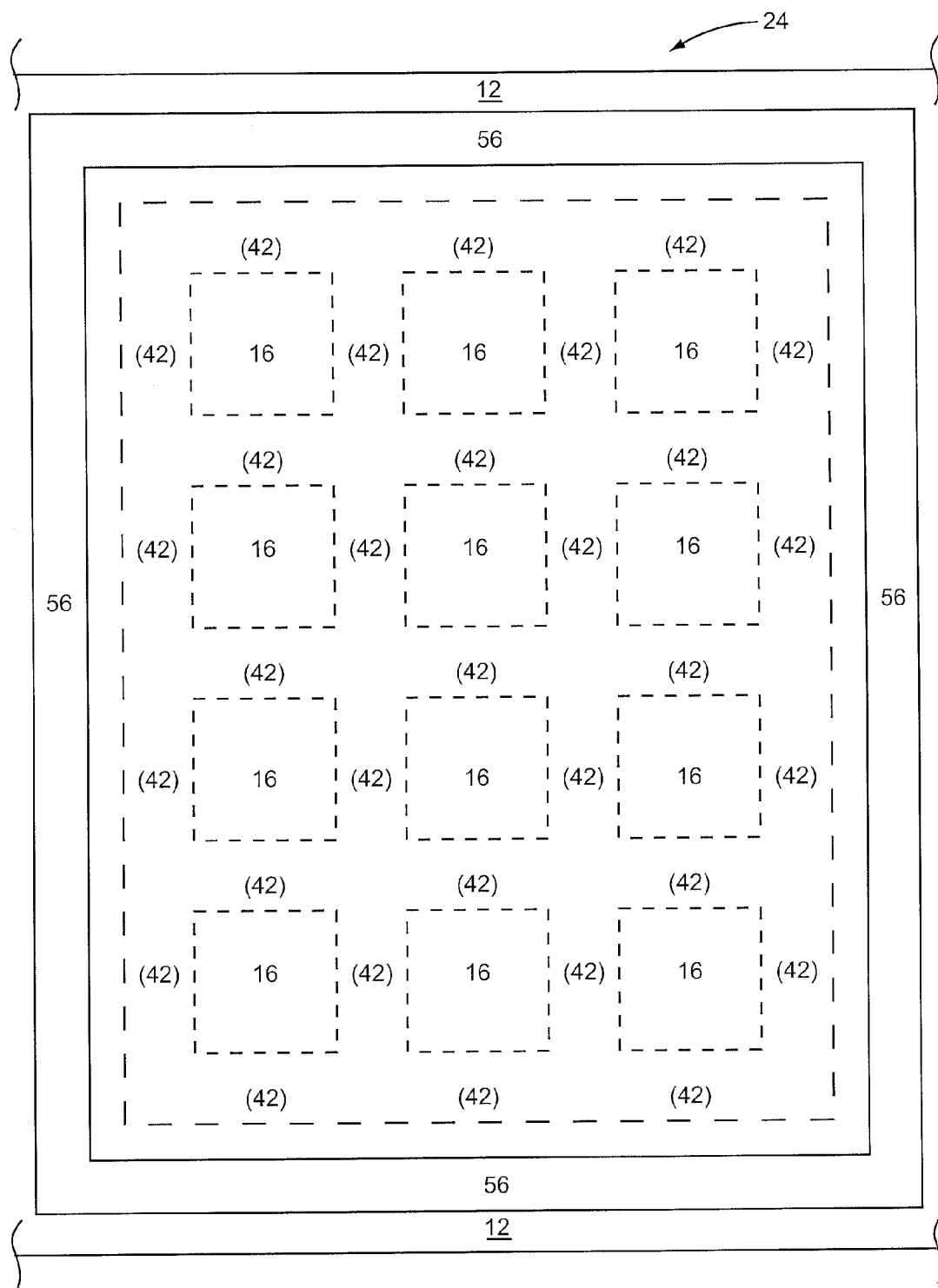

FIG. 22

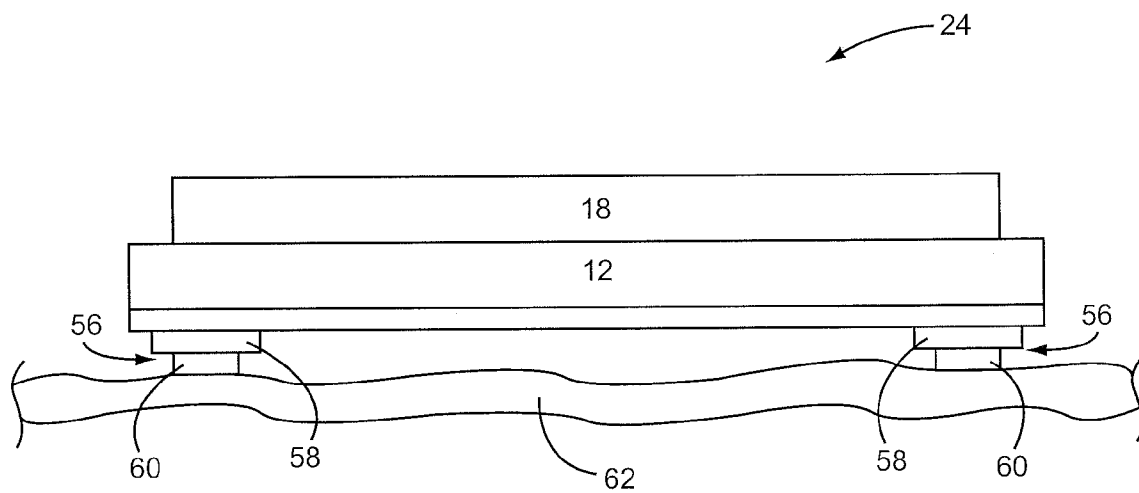

FIG. 23

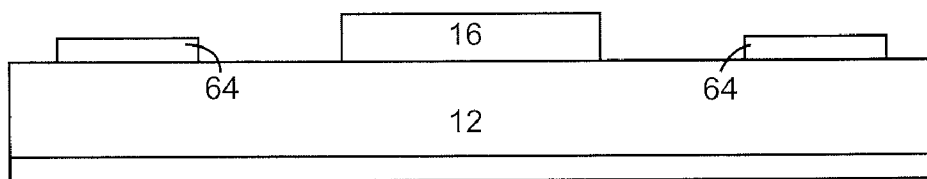

FIG. 24A

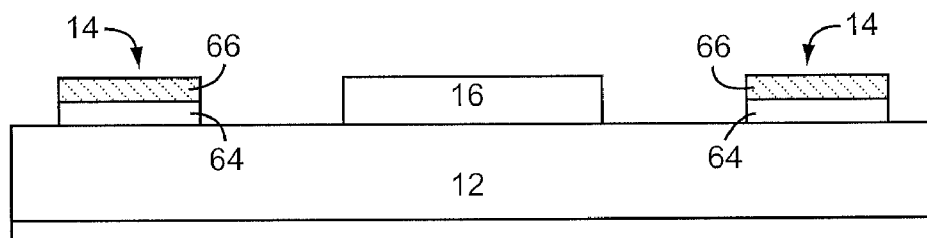

FIG. 24B

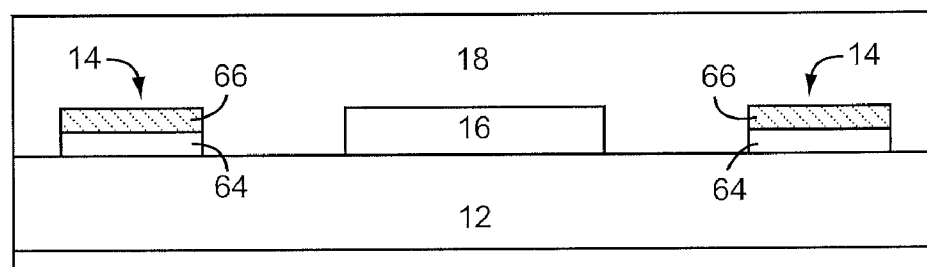

FIG. 24C

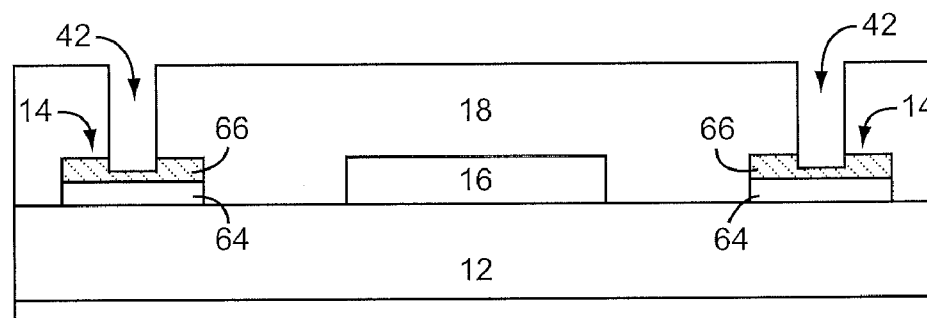

FIG. 24D

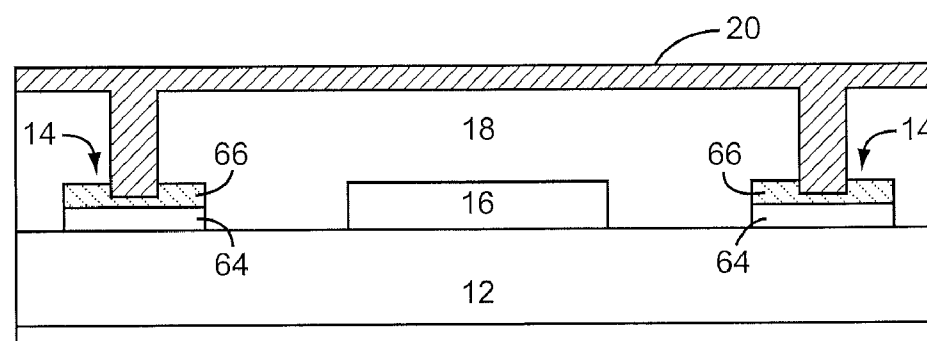

FIG. 24E

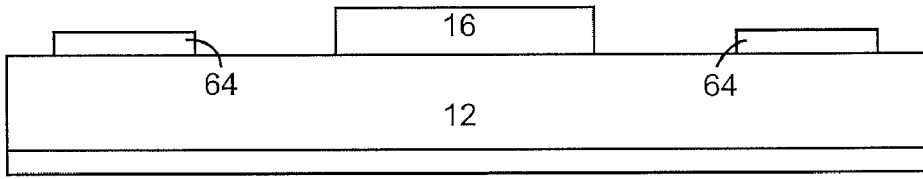

FIG. 25A

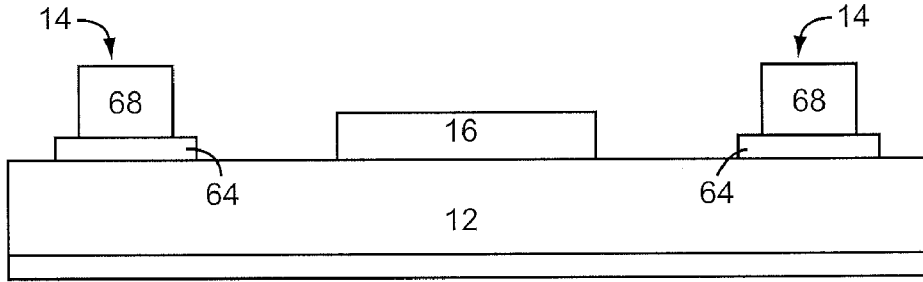

FIG. 25B

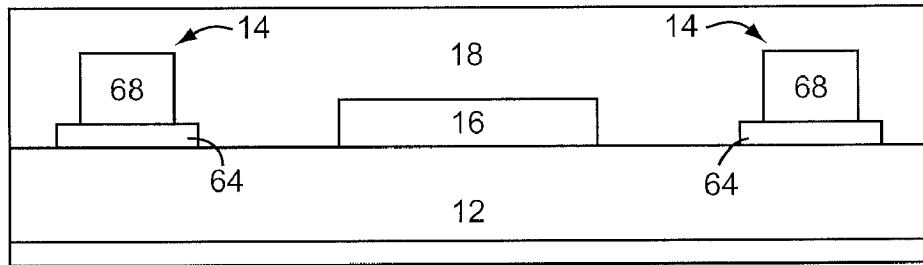

FIG. 25C

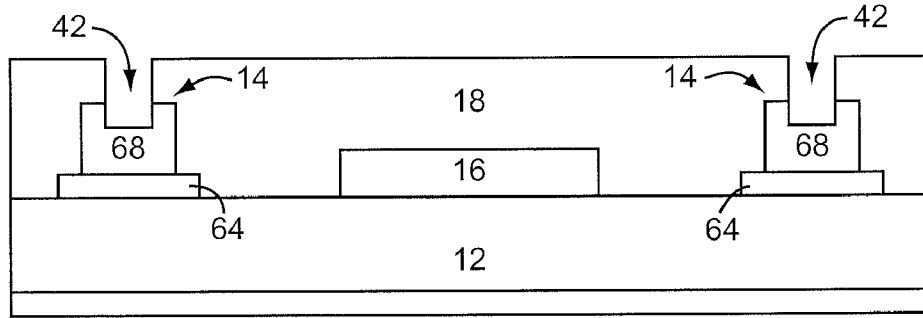

FIG. 25D

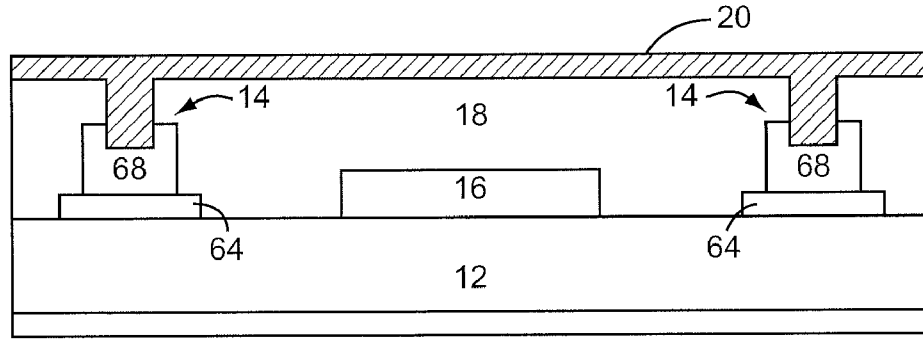

FIG. 25E

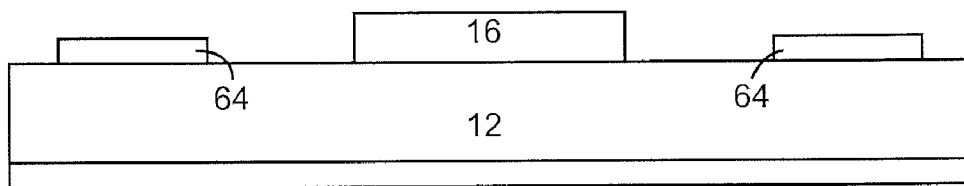

FIG. 26A

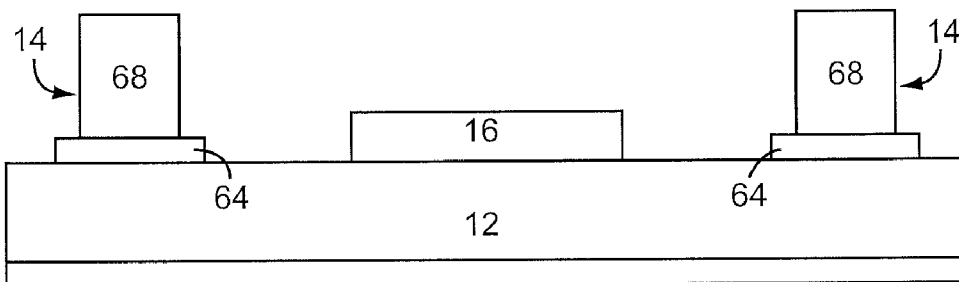

FIG. 26B

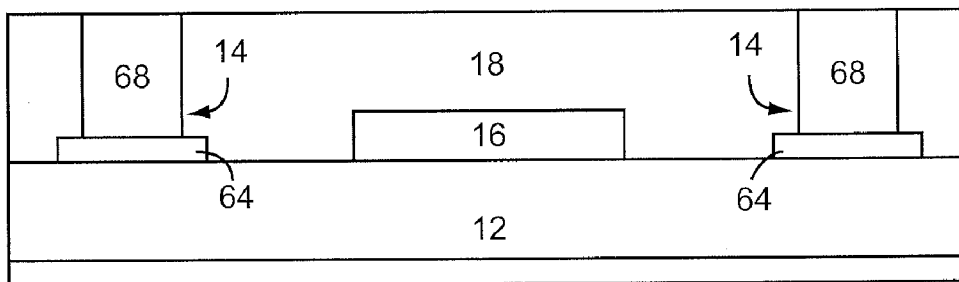

FIG. 26C

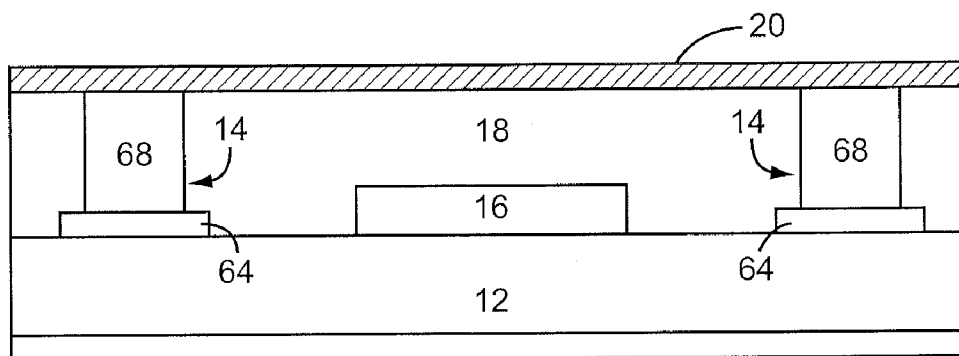

FIG. 26D



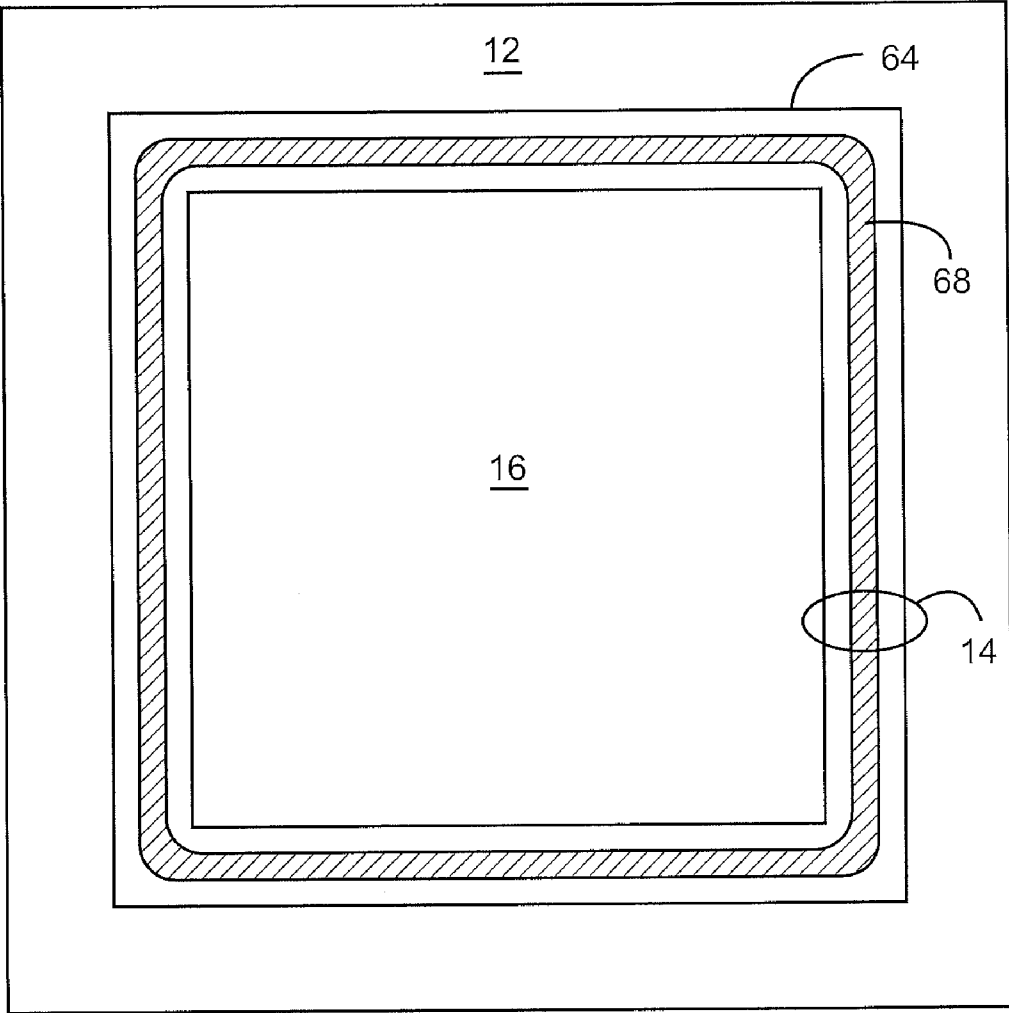

FIG. 27A

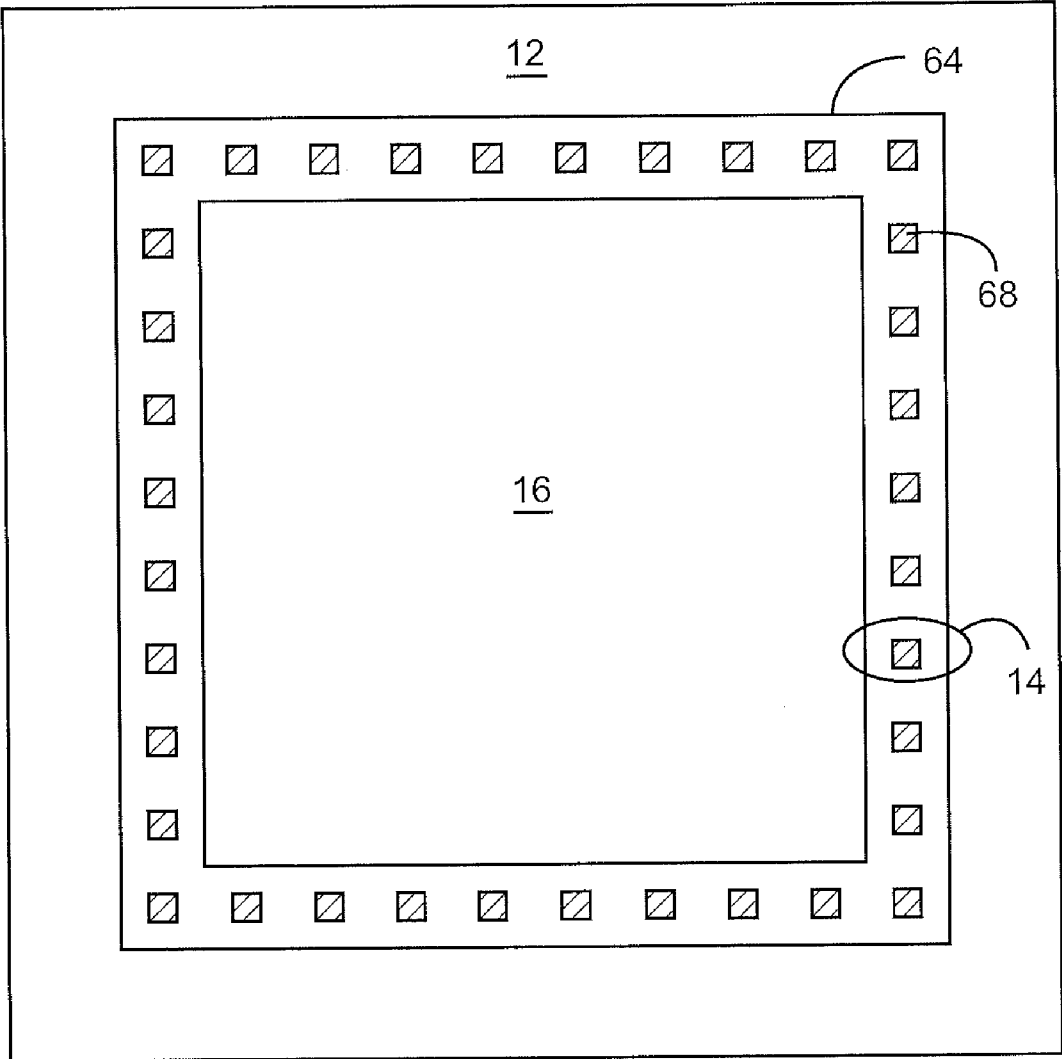

FIG. 27B

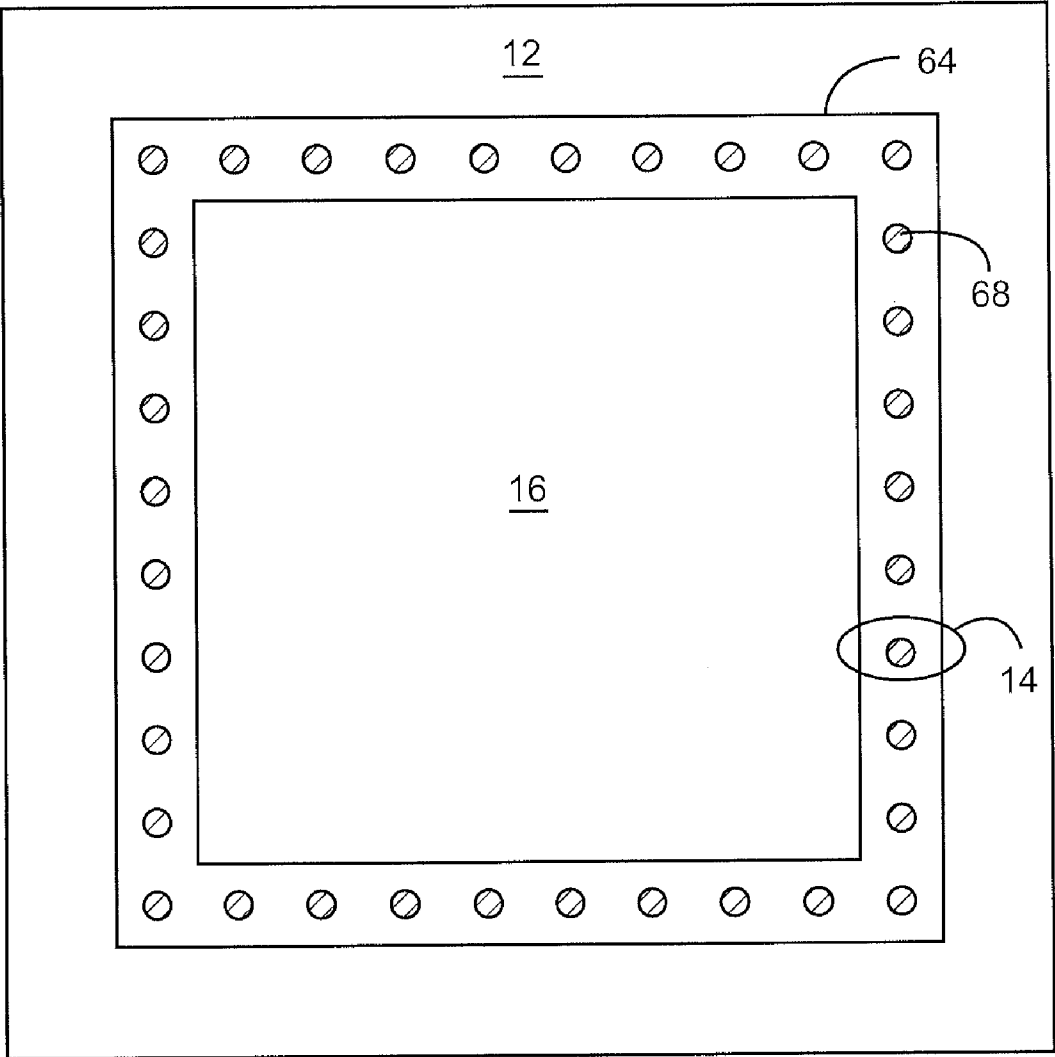

FIG. 27C

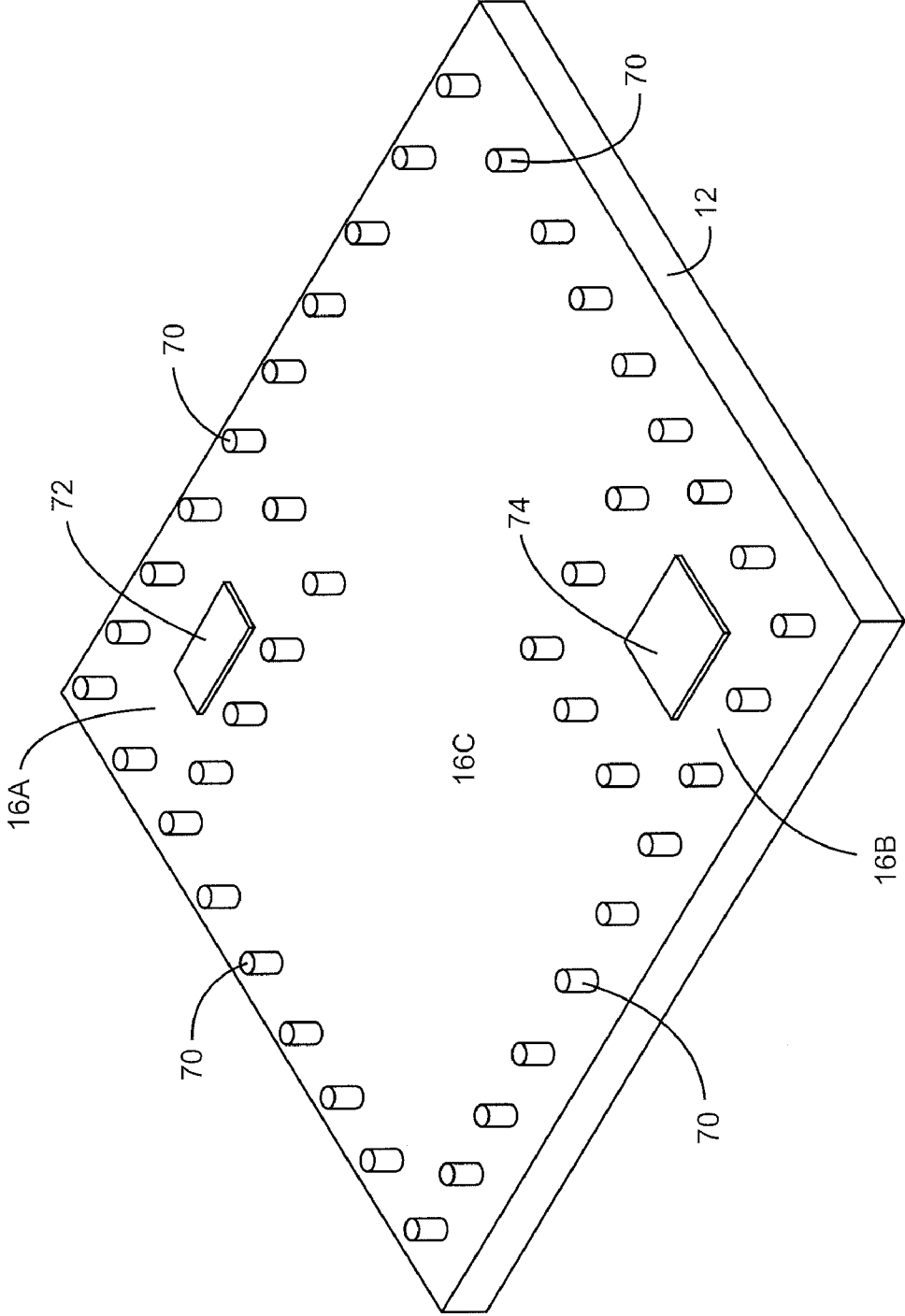

FIG. 28A

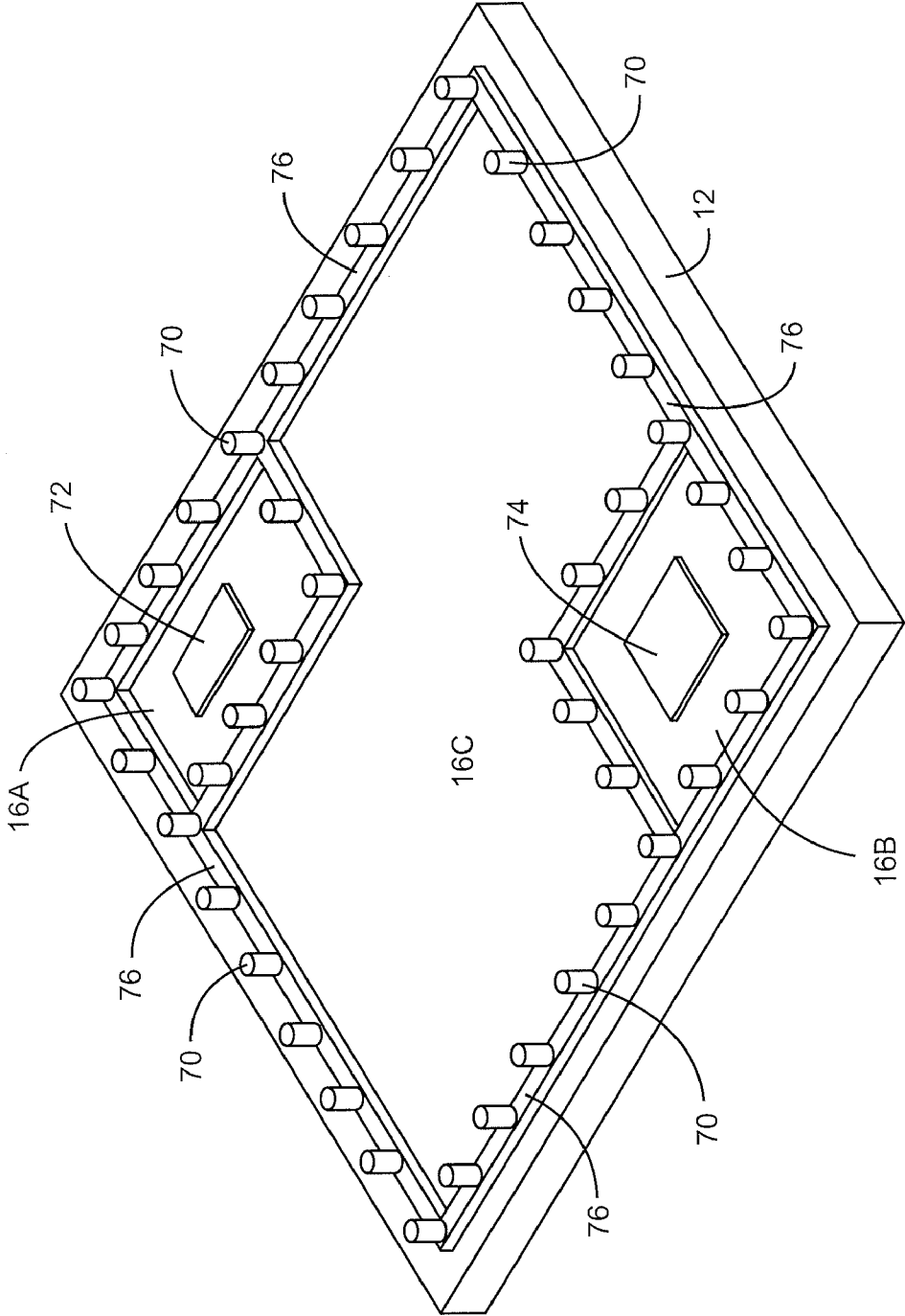

FIG. 28B

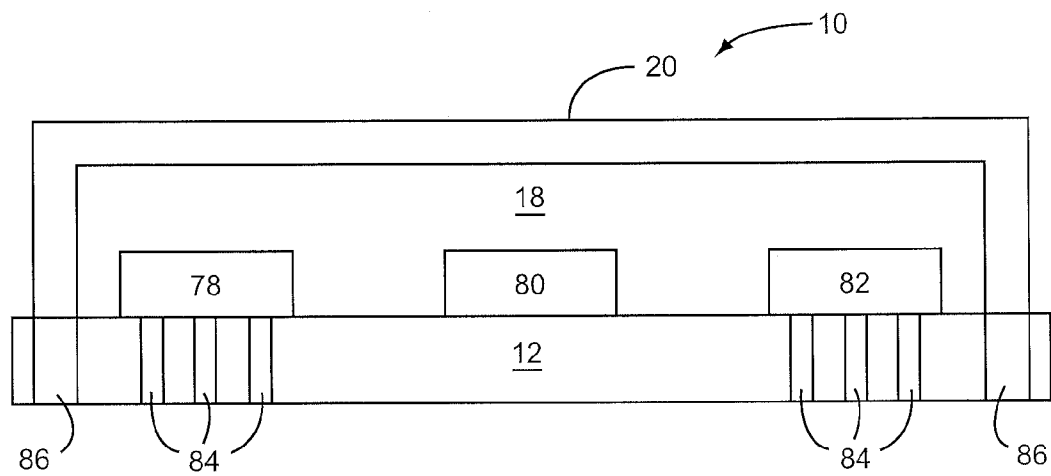

FIG. 29A

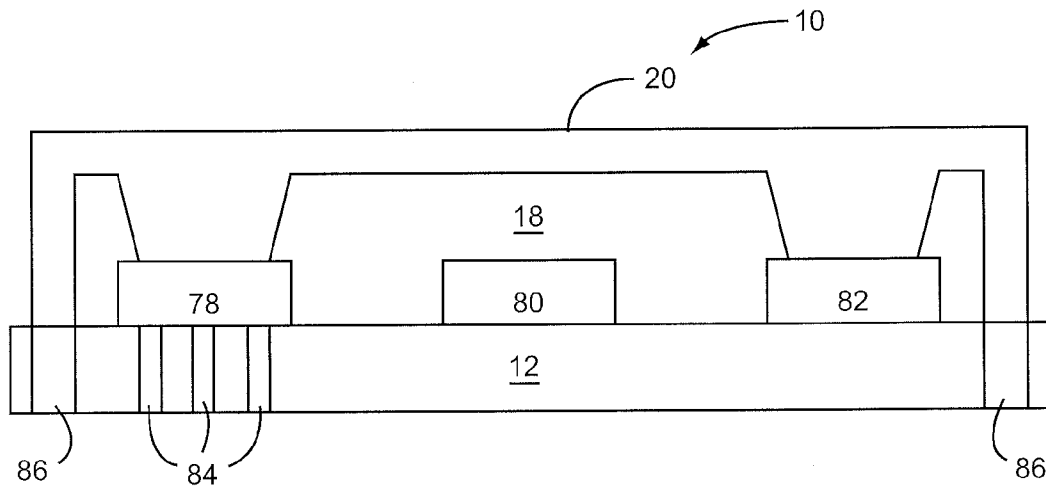

FIG. 29B

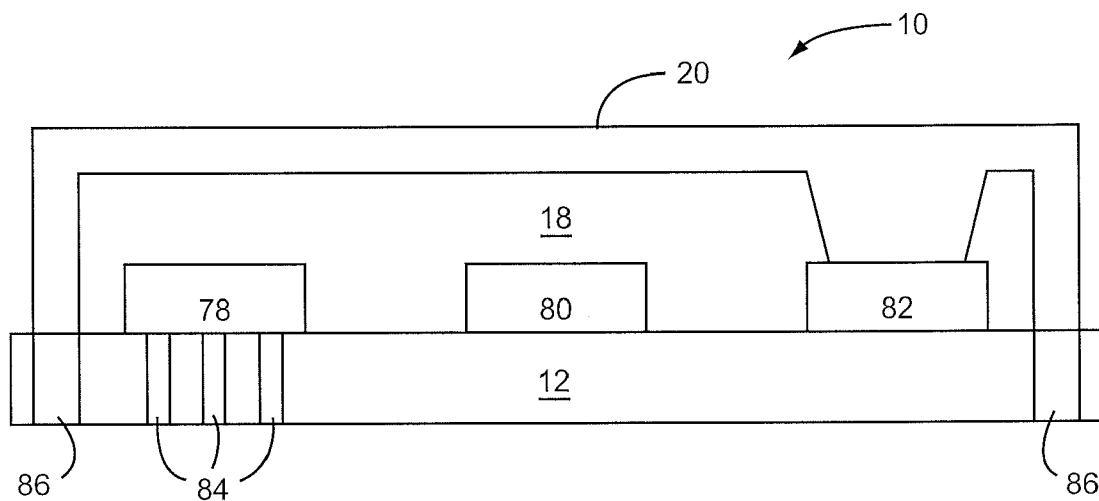

FIG. 29C

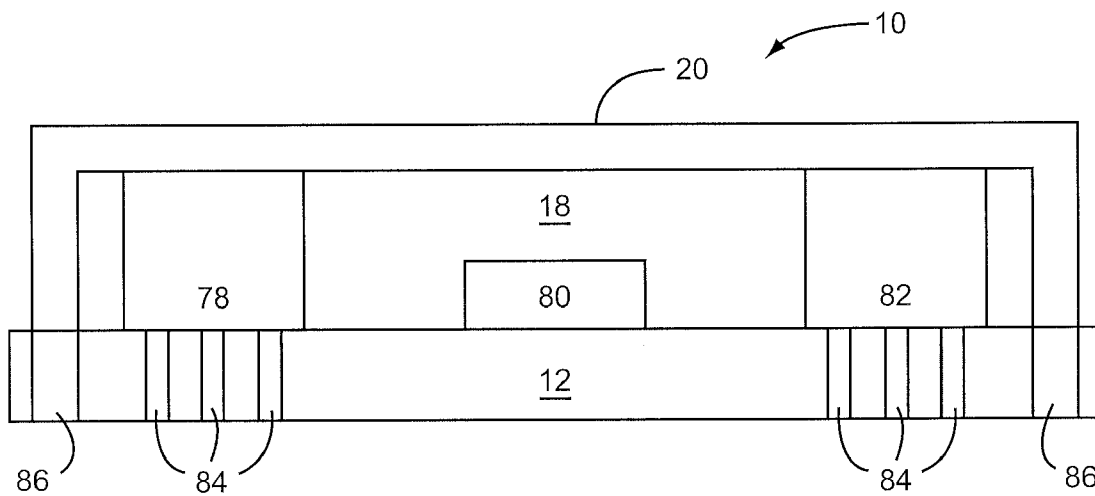

FIG. 29D

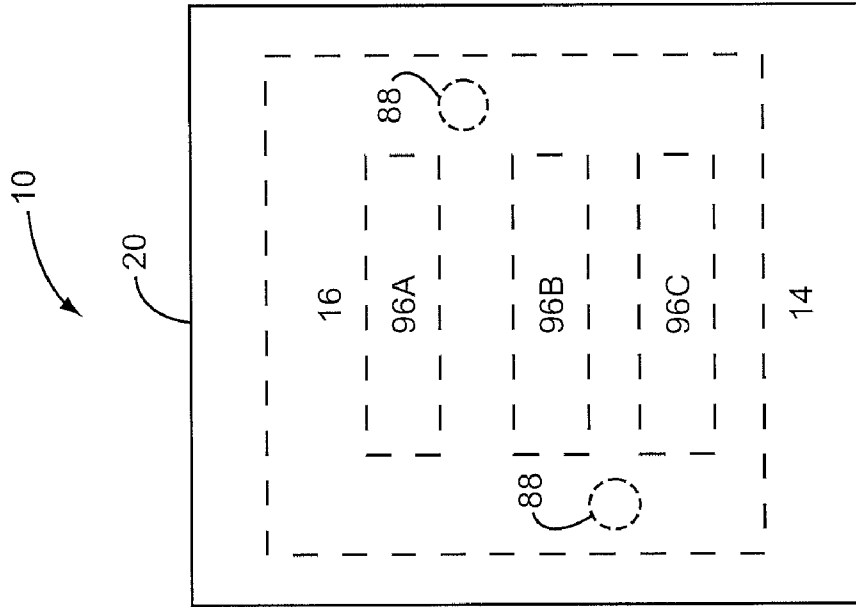

FIG. 30B

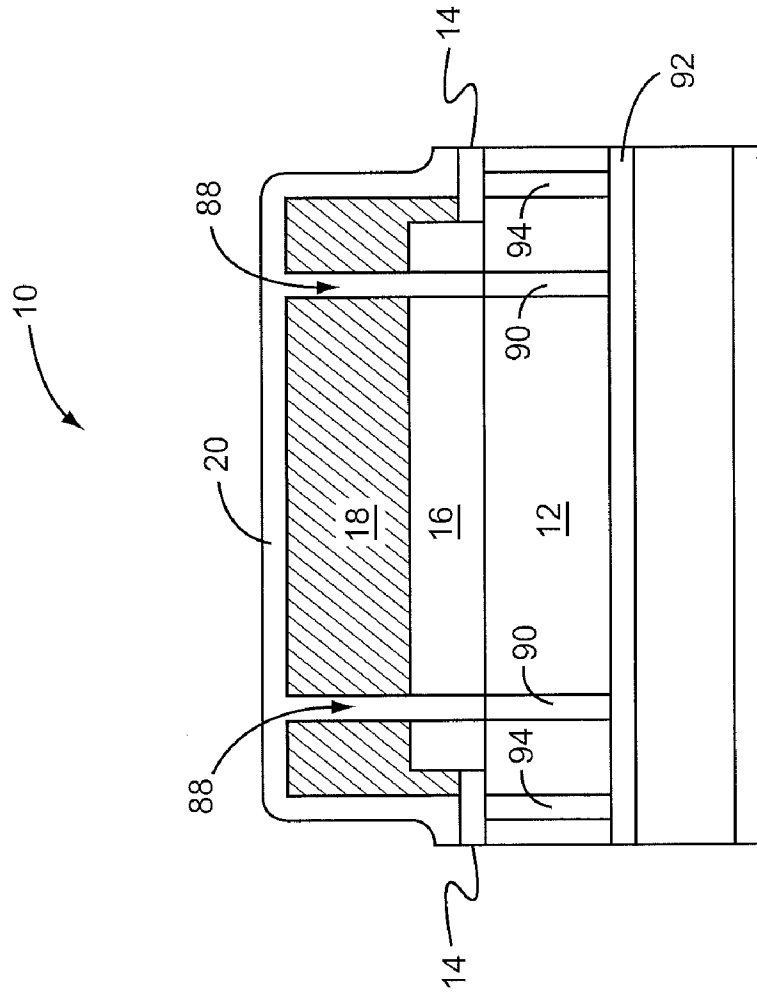

FIG. 30A



## CONFORMAL SHIELDING EMPLOYING SEGMENT BUILDUP

**[0001]** This application is a Continuation of U.S. patent application Ser. No. 11/952,545 filed Dec. 7, 2007, which claims the benefit of U.S. provisional patent applications 60/946,453 filed Jun. 27, 2007 and 60/978,006 filed Oct. 5, 2007, the disclosures of which are incorporated herein by reference in their entireties.

### CROSS-REFERENCE TO RELATED APPLICATIONS

**[0002]** This application is related to U.S. utility patent application Ser. No. 11/199,319 filed Aug. 8, 2005 now U.S. Pat. No. 7,451,539; U.S. utility patent application Ser. No. 11/435,913 filed May 17, 2006; U.S. utility patent application Ser. No. 11/768,014 filed Jun. 25, 2007; U.S. utility patent application Ser. No. 11/952,484 filed Dec. 7, 2007; U.S. utility patent application Ser. No. 11/952,513 filed Dec. 7, 2007; U.S. utility patent application Ser. No. 11/952,592 filed Dec. 7, 2007; U.S. utility patent application Ser. No. 11/952,617 filed Dec. 7, 2007; U.S. utility patent application Ser. No. 11/952,634 filed Dec. 7, 2007; U.S. utility patent application Ser. No. 11/952,670 filed Dec. 7, 2007; and U.S. utility patent application Ser. No. 11/952,690 filed Dec. 7, 2007, the disclosures of which are incorporated herein by reference in their entireties.

### FIELD OF THE INVENTION

**[0003]** The present invention relates to providing shielding for semiconductor modules, wherein the shielding is integrated with the semiconductor modules.

### BACKGROUND OF THE INVENTION

**[0004]** Electronic components have become ubiquitous in modern society. The electronics industry routinely announces accelerated clocking speeds, higher transmission frequencies, and smaller integrated circuit modules. While the benefits of these devices are myriad, smaller electronic components that operate at higher frequencies also create problems. Higher operating frequencies mean shorter wavelengths, where shorter conductive elements within electronic circuitry may act as antennas to unintentionally broadcast electromagnetic emissions throughout the electromagnetic spectrum. If the signal strengths of the emissions are high enough, the emissions may interfere with the operation of an electronic component subjected to the emissions. Further, the Federal Communications Commission (FCC) and other regulatory agencies regulate these emissions, and as such, these emissions must be kept within regulatory requirements.

**[0005]** One way to reduce emissions is to form a shield about the modules that either cause emissions or are sensitive to emissions. Typically, a shield is formed from a grounded conductive structure that covers a module or a portion thereof. When emissions from electronic components within the shield strike the interior surface of the shield, the electromagnetic emissions are electrically shorted through the grounded conductive material that forms the shield, thereby reducing emissions. Likewise, when external emissions from outside the shield strike the exterior surface of the shield, a similar electrical short occurs, and the electronic components on the module do not experience the emissions.

**[0006]** However, as modules continue to become smaller from miniaturization, creating effective shields that do not materially add to the size of the module becomes more difficult. Thus, there is a need for a shield that is inexpensive to manufacture on a large scale, does not substantially change the size of the module, and effectively deals with interference caused by unwanted electromagnetic emissions.

### SUMMARY OF THE INVENTION

**[0007]** The present invention may be used to form one or more shields for corresponding component areas of a given module. In one embodiment, a meta-module having circuitry for two or more modules is formed on a substrate, which is preferably a laminated substrate. As such, the circuitry for the different modules is initially formed on the single meta-module. Each module will have one or more component areas in which the circuitry is formed. A metallic structure is formed on or in the substrate for each component area to be shielded on the substrate. In one embodiment, each metallic structure extends about all or a portion of the periphery of each of the component areas to be shielded. A single body, such as an overmold body, is then formed over all of the modules on the meta-module. After the body is formed, at least a portion of the metallic structure for each component area to be shielded is exposed through the body by a cutting, drilling, or like operation. Next, an electromagnetic shield material is applied to the exterior surface of the body of each of the component areas to be shielded and in contact with the exposed portion of the metallic structures. The modules are then singulated from each other to form separate modules, each of which having one or more integrally shielded component areas.

**[0008]** Those skilled in the art will appreciate the scope of the present invention and realize additional aspects thereof after reading the following detailed description of the preferred embodiments in association with the accompanying drawing figures.

### BRIEF DESCRIPTION OF THE DRAWING FIGURES

**[0009]** The accompanying drawing figures incorporated in and forming a part of this specification illustrate several aspects of the invention, and together with the description serve to explain the principles of the invention.

**[0010]** FIG. 1A illustrates a module having one sub-module, which is covered by an overmold body according to an example of the present invention.

**[0011]** FIG. 1B illustrates a cross-section of the module of FIG. 1A in which an integrated electromagnetic shield is provided according to one embodiment of the present invention.

**[0012]** FIG. 2A illustrates a module having two sub-modules, which are covered by an overmold body according to an example of the present invention.

**[0013]** FIG. 2B illustrates a cross-section of the module of FIG. 2A in which an integrated electromagnetic shield is provided according to one embodiment of the present invention.

**[0014]** FIG. 3A illustrates a laminate structure having several electronic sub-module components according to the embodiment illustrated in FIGS. 1A and 1B.

[0015] FIG. 3B illustrates a sub-module having a component area positioned on a laminate with an exposed metallic layer grid according to the embodiment illustrated in FIG. 3A.

[0016] FIG. 4A illustrates a laminate structure having several electronic sub-module component areas according to the embodiment illustrated in FIGS. 2A and 2B.

[0017] FIG. 4B illustrates a sub-module having a component area positioned on a laminate within an exposed metallic layer grid according to the embodiment illustrated in FIG. 4A.

[0018] FIG. 5 illustrates a strip of meta-modules according to one embodiment of the present invention.

[0019] FIG. 6 is a sectional view of a meta-module according to one embodiment of the present invention.

[0020] FIG. 7 illustrates the strip of meta-modules of FIG. 5 after a cutting or drilling operation is provided to expose portions of the peripheral metallic structure about each component area according to one embodiment of the present invention.

[0021] FIG. 8A illustrates a top plan view of part of the meta-module of FIG. 6 with singulation lines illustrated for creating modules like that illustrated in FIGS. 1A and 1B.

[0022] FIG. 8B illustrates a top plan view of part of the meta-module of FIG. 6 with singulation lines illustrated for creating a modules like that illustrated in FIGS. 2A and 2B.

[0023] FIG. 9 is a flow diagram illustrating a manufacturing process according to a first embodiment of the present invention.

[0024] FIG. 10 illustrates an exemplary module constructed according to the embodiment of FIG. 9.

[0025] FIG. 11 is a flow diagram illustrating a manufacturing process according to a second embodiment of the present invention.

[0026] FIG. 12 illustrates an exemplary module constructed according to the embodiment of FIG. 11.

[0027] FIGS. 13A and 13B illustrate isolated component areas to be shielded according one embodiment of the present invention.

[0028] FIGS. 14A through 14D illustrate a process for providing isolated electromagnetic shields on a given module according to one embodiment of the present invention.

[0029] FIGS. 15A through 15F illustrate a process employing a sub-dicing or like mechanical cutting process for providing an integrated electromagnetic shield according to one embodiment of the present invention.

[0030] FIGS. 16A through 16D illustrate a process employing a laser cutting process for providing an integrated electromagnetic shield according to one embodiment of the present invention.

[0031] FIGS. 17A through 17D illustrate a process employing a mechanical or laser drilling process for providing an integrated electromagnetic shield according to one embodiment of the present invention.

[0032] FIGS. 18A through 18F illustrate a process employing a molding form for providing an integrated electromagnetic shield according to one embodiment of the present invention.

[0033] FIG. 19 illustrates a meta-module without support structures underneath openings that are cut through an over-mold body according to one embodiment of the present invention.

[0034] FIG. 20 illustrates a meta-module with support structures underneath openings that are cut through an over-mold body according to one embodiment of the present invention.

[0035] FIG. 21 illustrates the bottom surface of a laminate that includes support structures, such as those provided in FIG. 20.

[0036] FIG. 22 illustrates the bottom surface of a laminate on which a seal ring structure is formed according to one embodiment of the present invention.

[0037] FIG. 23 illustrates the side view of a meta-module where a seal ring structure is provided on the bottom side of the laminate on which the meta-module is formed according to one embodiment of the present invention.

[0038] FIGS. 24A through 24E illustrate a process for providing an integrated electromagnetic shield where the metallic layer grid is built up in part using a plating process according to one embodiment of the present invention.

[0039] FIGS. 25A through 25E illustrate a process for providing an integrated electromagnetic shield where the metallic layer grid is built up in part using surface mount structures according to one embodiment of the present invention.

[0040] FIGS. 26A through 26D illustrate a process for providing an integrated electromagnetic shield where the metallic layer grid is built up in part using surface mount structures according to another embodiment of the present invention.

[0041] FIGS. 27A through 27C illustrate different configurations for the surface mount structures according to select embodiments of the present invention.

[0042] FIG. 28A illustrates a metallic layer grid formed from metallic studs on the top surface of the substrate according to one embodiment of the present invention.

[0043] FIG. 28B illustrates a metallic layer grid formed from metallic studs on a metal trace that resides on the top surface of the substrate according to one embodiment of the present invention.

[0044] FIG. 29A illustrates a cross-section of a module in which an integrated electromagnetic shield is provided according to one embodiment of the present invention.

[0045] FIGS. 29B through 29D illustrate cross-sections of different modules in which the integrated electromagnetic shield is also configured to act as a thermal path or heat sink according to one embodiment of the present invention.

[0046] FIGS. 30A and 30B are cross-sectional and top views, respectively, of a module that includes field barrier structures associated with the integrated electromagnetic shield according to one embodiment of the present invention.

#### DETAILED DESCRIPTION OF THE PREFERRED EMBODIMENTS

[0047] The embodiments set forth below represent the necessary information to enable those skilled in the art to practice the invention and illustrate the best mode of practicing the invention. Upon reading the following description in light of the accompanying drawing figures, those skilled in the art will understand the concepts of the invention and will recognize applications of these concepts not particularly addressed herein. It should be understood that these concepts and applications fall within the scope of the disclosure and the accompanying claims.

[0048] The present invention may be used to form one or more shields for corresponding component areas of a given module. In one embodiment, a meta-module having circuitry for two or more modules is formed on a substrate, which is

preferably a laminated substrate. As such, the circuitry for the different modules is initially formed on the single meta-module. Each module will have one or more component areas in which the circuitry is formed. A metallic structure is formed on or in the substrate for each component area to be shielded on the substrate. The metallic structure may be formed from traces, vias, metallic layers, metallic components, plating materials, or the like, as well as any combination thereof. In one embodiment, each metallic structure extends about all or a portion of the periphery of each of the component areas to be shielded. A single body, such as an overmold body, is then formed over all of the modules on the meta-module. After the body is formed, at least a portion of the metallic structure for each component area to be shielded is exposed through the body by a cutting, drilling, or like operation. Next, an electromagnetic shield material is applied to the exterior surface of the body of each of the component areas to be shielded and in contact with the exposed portion of the metallic structures. The modules are then singulated from each other to form separate modules, each of which having one or more integrally shielded component areas.

**[0049]** In one embodiment, the electromagnetic shield material is provided using an electroless plating process, which deposits a conductive seed layer on the overmold body and in contact with the exposed portions of the metallic structures. Then, an electrolytic plating process is used to deposit a second conductive layer onto the seed layer. A final layer of a metallic material, such as nickel, is then deposited on top of the second conductive layer through an electrolytic plating process. In another embodiment, the electromagnetic shield is provided by applying a conductive epoxy or paint to the body and in contact with the exposed portion of the metallic structures. In both embodiments, the conductive layers create an integrated electromagnetic shield for one or more component areas of a module to reduce electromagnetic interference (EMI).

**[0050]** For the following description, the preferred embodiments of the present invention are described. The scope of the invention and the claims that follow shall not be limited to these preferred embodiments. For example, the metallic structure in the preferred embodiments is formed in whole or in part from a metallic layer grid that resides on or in the surface of the substrate. Further, the metallic structure resides along all or a portion of the periphery of one or more component areas. These embodiment lend themselves to efficient processing; however, those skilled in the art will recognize that the metallic structure to which the integrated electromagnetic shield is connected need not reside along the periphery of the component area, or be part of a metallic layer grid. Importantly, the metallic structure may take virtually any form or shape, and may reside on or in the top surface of the substrate. The metallic structure may merely be a single point along the top surface of the module, as well as a continuous or segmented structure that extends along all or a portion of the one or more component areas to be shielded. Accordingly, the metallic layer grid used in the following embodiments to provide a metallic structure is merely provided to illustrate the preferred embodiments, and as such, shall not limit what constitutes a metallic structure or how a metallic structure is formed according to the present invention.

**[0051]** A module 10 is illustrated in FIGS. 1A and 1B according to one embodiment of the present invention. The module 10 has a laminate 12, which has a metallic structure that may be formed from a metallic layer grid 14 on or in a top

surface of the laminate 12 or like substrate. As indicated above, any metallic structure may be used; however, the preferred embodiment uses a portion of the metallic layer grid 14 to form a peripheral metallic structure. Only one section of the metallic layer grid 14 is depicted in these figures and the peripheral metallic structure is not separately labeled, as it is formed from the metallic layer grid 14. The illustrated module 10 has a single component area 16 that lies within the peripheral metallic structure and in which circuitry for the module 10 is formed. A body, such as an overmold body 18, which is formed from a dielectric material, resides over the laminate 12 and encompasses the component area 16. As depicted in FIG. 1B, an electromagnetic shield 20 is integrally formed over the overmold body 18 and in contact with the exposed portions of the peripheral metallic structure of the metallic layer grid 14.

**[0052]** A given module 10 may include any number of component areas 16 where one or more of the component area 16 has a corresponding electromagnetic shield 20. As illustrated in FIGS. 2A and 2B, two component areas 16A and 16B are positioned in the metallic layer grid 14 such that a peripheral metallic structure is provided for each of the component areas 16A and 16B. In certain instances, peripheral metallic structures for adjacent component areas 16A and 16B may share a common section of the metallic layer grid 14.

**[0053]** The illustrated module 10 has two component areas 16A and 16B, which lie within corresponding peripheral metallic structures and in which circuitry (not illustrated) for the module 10 is formed. Overmold bodies 18 reside over the laminate 12 and encompass the respective component areas 16A and 16B. As depicted in FIG. 2B, electromagnetic shields 20 are integrally formed over the overmold bodies 18 and in contact with the exposed portions of the respective peripheral metallic structures of the metallic layer grid 14. Although the component areas 16A and 16B of module 10 are illustrated as being adjacent one another, they may be substantially separated from one another, as will be described further below.

**[0054]** With reference to FIG. 3A, an extended laminate structure is illustrated wherein a metallic layer grid 14 is formed on or in the top surface of the laminate 12. The laminate structure includes numerous component areas 16, each of which includes the circuitry for a unique module 10, such as that depicted in FIGS. 1A and 1B where each module 10 includes a single component area 16. The illustrated metallic layer grid 14 formed on the laminate structure is a cross-hatch of metal traces, which have a defined width. Each opening of the metallic layer grid 14 forms a component area 16 in which circuitry of a module 10 is formed. FIG. 3B illustrates an isolated portion of the laminate structure that will ultimately be used to form a module 10 having a single component area 16, which is associated with a single sub-module 22. In this example, a continuous metal trace is formed about the periphery of each component area 16 and represents the peripheral metallic structure for the corresponding component area 16. The peripheral metallic structure or the metallic layer grid 14 from which it is formed does not need to be continuous or completely or even substantially surround the component area 16 as is illustrated further below. As used herein, the term "peripheral" is defined to be the outermost part or region within a precise boundary, in particular, the boundary formed by the peripheral edge of a component area 16. Notably, this peripheral edge for a mod-

ule 10 having a single component area 16 resides around the peripheral edge of the module 10. Further, the term “grid” is used merely to indicate that a repeating pattern of metallic structures, peripheral or otherwise, is formed on the meta-module 24 because of the presence of numerous modules. Sections of the metallic layer grid that are associated with different modules 10 or component areas 16 therein may be separate from each other.

[0055] With reference to FIG. 4A, another extended laminate structure is illustrated wherein a metallic layer grid 14 is formed on the top surface of the laminate 12. The laminate structure includes numerous component areas 16A and 16B. Each pair of component areas 16A and 16B includes the circuitry (not illustrated) for a unique module 10, such as that depicted in FIGS. 2A and 2B where each module 10 includes both component areas 16A and 16B. Each opening of the metallic layer grid 14 forms either a component area 16A or a component area 16B in which circuitry of a module 10 is formed. FIG. 4B illustrates an isolated portion of the laminate structure that will ultimately be used to form a module 10 having two component areas 16A and 16B, which are respectively associated with two sub-modules 22. In this example, a continuous metal trace of the metallic layer grid 14 is formed about the periphery of each component area 16A or 16B and represents the peripheral metallic structure for the corresponding component areas 16A and 16B. Again, the peripheral metallic structure or the metallic layer grid 14 from which it is formed does not need to be continuous or completely surround the component areas 16A or 16B.

[0056] FIG. 5 illustrates four meta-modules 24 on an extended strip of laminate 12. Each meta-module 24 includes a metallic layer grid 14 and component areas 16 (16A, 16B) for numerous modules 10. An extended overmold body 18 covers most of each meta-module 24, the metallic layer grid 14, and the component areas 16 therein. The overmold body 18 may be a plastic dielectric material or the like, as is conventionally used for overmolding in semiconductor fabrication processes. Again, other materials and processes may be used to form a body providing a similar protective encapsulation as that provided by an overmold process. As such, each meta-module 24 will ultimately be used to create numerous modules 10, where each module 10 may have one or more component areas 16 that correspond to sub-modules 22 depending on design requirements. A cross-section of a meta-module 24 is illustrated in FIG. 6.

[0057] As illustrated, each component area 16 to be shielded for all of the modules 10 on the meta-module 24 may have a peripheral metallic structure, which is part of the metallic layer grid 14. After the single overmold body 18 is formed over all of the modules 10 on the meta-module 24, at least a portion of the peripheral metallic structure for each component area 16 of each module 10 is exposed through the single overmold body 18 by a cutting, drilling, or like operation, as illustrated in FIG. 7. This exposing step effectively cuts or drills through the overmold body 18 to or into, but preferably not through, all or select portions of the peripheral metallic structure of the metallic layer grid 14. Depending on design criteria, each meta-module 24 is cut or drilled such that the overmold body 18 of each component area 16 to be shielded is distinct from one another to form sub-modules 22. Although various exposing techniques are described further below, an exemplary technique employs sub-dicing. After portions of the peripheral metallic structure are exposed, an electromagnetic shield material is applied to all or a portion of

the exterior surface of the overmold body 18 of each of the modules 10 and in contact with the exposed portion of the peripheral metallic structure to form an electromagnetic shield 20. The meta-module 24 is then singulated to form individual modules, which have one or more integrally shielded component areas, as will be described in detail below.

[0058] FIG. 8A illustrates a top plan view of part of a meta-module 24 after sub-dicing, but before separation. In this example, the metallic layer grid 14 is exposed around the periphery of each sub-module 22, where each sub-module 22 corresponds to a portion of the meta-module 24 for a given component area 16. The dashed lines represent cuts to be made in a subsequent singulation process to form individual modules 10, which have a single sub-module 22. The singulation process separates the modules 10 from one another. Although each module 10 is shown having a single sub-module 22, those skilled in the art will recognize that a module 10 may include any number of sub-modules 22. For example, FIG. 8B illustrates an embodiment where each module 10 will include two adjacent sub-modules 22.

[0059] FIG. 9 provides a process flow diagram detailing the steps for creating the module 10 that is illustrated in FIG. 10 according to one embodiment of the present invention. In particular, a meta-module 24 is formed, wherein each sub-module 22 within the meta-module 24 has a peripheral metallic structure about the periphery of the component areas 16 to be shielded (step 100). The peripheral metallic structure is formed from the metallic layer grid 14.

[0060] Next, at least a portion of the peripheral metallic structure associated with each sub-module 22 is exposed through the overmold body 18 (step 102). For example, a sub-dicing process may be employed to cut through the overmold body 18 of each sub-module 22 to be shielded and to the metallic layer grid 14. Other exposing techniques are described further below. At this point, a portion of the metallic layer grid 14 is exposed about the periphery of the overmold body 18 for each sub-module 22.

[0061] The exposed surface of the overmold body 18 may be cleaned, preferably using a plasma cleaning process, to remove wax or other organic compounds and materials that remain on the surfaces of the overmold body 18 (step 104). The plasma cleaning process subjects the surface of the overmold body 18 to a reactive process gas, such as Argon, Oxygen, Nitrogen, Hydrogen, Carbon Tetrafluoride, Sulfur Hexafluoride, Nitrogen Tri-fluoride, or the like, which effectively etches away contaminants on the exposed surface of the overmold body 18. In essence, the contaminants are vaporized, burned, or otherwise removed from the exposed surface of the overmold body 18 when exposed to the process gas. Subsequently, the cleaned surface of the overmold body 18 for each sub-module 22 is preferably roughened through an abrasion process, a desmear technique, or like process (step 106). In one embodiment, a chemical roughening process is provided. It should be appreciated that a mask (not shown) may be positioned on the underside of the laminate 12 so that the processes described in the steps below do not interfere with any electrical contacts (not shown) on the bottom side of each sub-module 22. The mask helps prevent liquids and gases from reaching these electrical contacts, which may act as input/output contacts for the module 10. Alternatively, a seal structure may be employed, such as that described further below.

[0062] After roughening, an electroless plating process is performed to deposit a seed layer 26 of a conductive material on top of the overmold body 18 of the sub-module 22 and in contact with the exposed portions of the metallic layer grid 14 (step 108). In an exemplary embodiment, the seed layer 26 of conductive material may be Copper (Cu), Aluminum (Al), Silver (Ag), Gold (Au), or other material as needed or desired. An electroless plating process is defined herein to be a chemical deposition of metal instead of electrical-based deposition.

[0063] An exemplary electroless plating process of Cu on a dielectric substrate may require prior deposition of a catalyst such as a palladium-tin (Pd—Sn) colloid consisting of a metallic Pd core surrounded by a stabilizing layer of Sn ions. The activation step (deposition of the colloid) is usually followed by an acceleration step (removal of excess ionic tin). Adhesion of the deposit to the substrate is improved by the mechanical or chemical pretreatment steps described above. Other electroless plating processes could also be used and are considered within the scope of the present invention.

[0064] After the seed layer 26 of conductive material is created over the overmold body 18 of the sub-module 22 and in contact with the exposed portions of the metallic layer grid 14, an electrolytic plating process is performed to deposit a second layer 28 of conductive material on top of the initially deposited seed layer 26 (step 110). In an exemplary embodiment, the second layer 28 of conductive material may be Cu, Al, Ag, Au, or other material as needed or desired. It should be appreciated that the exposed portions of metallic layer grid 14 are electrically coupled to the seed layer 26, and the seed layer 26 then carries the current for the electrolytic plating process.

[0065] After the second layer 28 is generated, a third layer 30 is created on top of the second layer 28 through a second electrolytic plating process (step 112). The third layer 30 may be comparatively a poor conductor, and may be a layer of low stress nickel (Ni) or the like. Nickel serves to protect the conductive layers so that they do not tarnish, corrode, or otherwise suffer from environmental effects. Likewise, nickel may contribute to the shielding function by absorbing electromagnetic radiation.

[0066] In an exemplary embodiment, the seed layer 26, the second layer 28, and the third layer 30 form a shield 32, which is approximately 10-50  $\mu\text{m}$  thick. Greater or lesser thicknesses may also be generated. At least one metallic coated or filled via 34 may electrically couple the peripheral metallic structure of the metallic layer grid 14 to a ground plane 36 on the bottom of or within the laminate 12 so that the peripheral metallic structure of the metallic layer grid 14 and the shield 32 are electrically grounded. The shield 32, vias 34, and ground plane 36 form an encapsulating shielding structure, which substantially encompasses the component area 16 of each sub-module 22.

[0067] After the electrolytic plating process of step 110, the meta-module 24 is singulated to form modules 10 having two or more sub-modules 22 (step 114). As used herein, the term “singulation” is defined to be the process wherein the individual modules 10 are separated one from the other using a cutting or like process, such that each module 10 is a single module. Finally, the mask, which is positioned on the underside of the strip of laminate 12, may be removed from an input/output (I/O) side 38 of the module 10 (step 116). It should be appreciated that some steps may be rearranged in the present process. For example, the mask may be removed prior to singulation. Likewise, if a layer 26, 28 or 30 is too thick, the layer may be ground or etched down to a desired

thickness. Again, the end result of this embodiment may be a module 10 having two shielded sub-modules, as illustrated in FIG. 10, although the module 10 may be configured to have one or more sub-modules 22, where some or all of the sub-modules 22 have a shield 32. Although a particular plating process is described, various electroless or electrolytic plating techniques of any number of layers may be employed.

[0068] FIG. 11 illustrates a process flow diagram detailing the steps for creating the module 10 that is illustrated in FIG. 12 according to one embodiment of the present invention. As above, a meta-module 24 is initially formed, wherein each sub-module 22 within the meta-module 24 has a peripheral metallic structure about the periphery of the component areas 16 to be shielded (step 200), and the peripheral metallic structure is formed from the metallic layer grid 14.

[0069] Next, at least a portion of the peripheral metallic structure associated with each sub-module 22 is exposed through the overmold body 18 (step 202). Again, a sub-dicing process may be employed to cut through the overmold body 18 of each sub-module 22 and to the metallic layer grid 14, while other possible exposing techniques are described further below. At this point, a portion of the metallic layer grid 14 is exposed about the periphery of the overmold body 18 for each sub-module 22.

[0070] The exposed surface of the overmold body 18 may be cleaned, preferably using a plasma cleaning process, to remove wax or other organic compounds and materials that remain on the surface of the overmold body 18 (step 204). Subsequently, the cleaned surface of the overmold body 18 for each sub-module 22 may be roughened through an abrasion process, a desmear technique, or like process (step 206).

[0071] After roughening, a conductive fleck-filled epoxy 40 may be sprayed over the overmold body 18 of each of the sub-modules 22 and in contact with the metallic layer grid 14 (step 208). In an exemplary embodiment, the conductive fleck-filled epoxy 40 is CHO-SHIELD 610 sold by Chomerics of 77 Dragon Court, Woburn, Mass. 01801. In certain embodiments, the conductive flecks of the conductive fleck-filled epoxy 40 may be Cu, Ag, a mixture of Cu and Ag, a tin/zinc (Sn/Zn) alloy, or other conductive material as needed or desired. Those skilled in the art will recognize other available conductive sprays to use for shielding material. While CHO-SHIELD 610 has an epoxy 40 to carry the conductive flecks, other materials such as polyurethane, acrylic, urethane, or the like could be the medium in which the conductive flecks are carried. Further, multiple coats of shielding material may be applied.

[0072] One or more metallic coated or filled vias 34 may electrically couple the metallic layer grid 14 to a ground plane 36 on the bottom of or within the laminate 12 so that the metallic layer grid 14 and the conductive fleck-filled epoxy 40 are electrically grounded. The conductive fleck-filled epoxy 40, vias 34, and ground plane 36 form a shielding structure, which substantially encompasses the component area 16A or 16B of each sub-module 22.

[0073] After application of the conductive fleck-filled epoxy 40, the meta-module 24 is singulated to form modules 10 having one or more sub-modules 22 (step 210). Again it should be appreciated that a mask may be removed from an input/output side 38 of the module 10 (step 212). This mask may be removed before singulation if needed or desired.

[0074] In the above embodiments, the various component areas 16A and 16B that are provided in a module 10, which has multiple sub-modules 22, were illustrated as being sub-

stantially adjacent to one another. As such, a portion of the peripheral metallic structure for the adjacent component areas 16A and 16B may be formed from the same portion of the metallic layer grid 14. In other words, the adjacent component areas 16A and 16B may share a common portion of a peripheral metallic structure. However, separate component areas 16 that are located on a single module 10 may be spaced apart from one another and may be associated with peripheral metallic structures that are physically separate from one another, electrically isolated from one another, or both. In certain embodiments, resultant shielding structures may be isolated from one another electrically, while other structures may have their structures substantially physically isolated from one another, wherein the respective shielding structures may be coupled to one another through one or more dedicated traces on the surface of the laminate structure or through electrical connections therein.

[0075] With reference to FIG. 13A, a module 10 is illustrated as having three component areas 16A, 16B, 16C. In this embodiment, assume that component areas 16A and 16B are to be shielded, and component area 16C will not be shielded, at least according to the shielding techniques of the present invention. As illustrated, component areas 16A and 16B are not adjacent to one another, and are physically separated from one another on the surface of the laminate 12 by component area 16C or other area. With reference to FIG. 13B, the peripheral metallic structures 14A and 14B of the metallic layer grid 14 are provided about the component areas 16A and 16B, respectively. Notably, the peripheral metallic structures 14A and 14B are at least physically isolated from one another, and depending on the electrical connections implemented on or within the laminate 12, may be electrically isolated from one another. In many embodiments, the peripheral metallic structures 14A and 14B may be ultimately electrically connected to different or the same ground planes, which are provided within the laminate structure. Such embodiments are particularly beneficial when the electrical components in the respective component areas 16A and 16B tend to interfere with one another, such as in the case where one component area 16A includes analog electronics and the other component area 16B includes digital electronics.

[0076] In such embodiments, all or a portion of the peripheral metallic structures 14A and 14B are exposed through an overmold body 18 (not illustrated in FIGS. 13A and 13B). Once these portions of the peripheral metallic structures 14A and 14B are exposed, the cleaning, roughing, and shield material application steps may be provided. If physical or electrical isolation of the respective shields for the component areas 16A and 16B is required, additional steps may be required to ensure that the shield material used to form the resultant electromagnetic shields 20 are isolated from one another. An exemplary process to maintain separation between the shields 20 for the respective component areas 16A and 16B is illustrated in FIGS. 14A-14D.

[0077] With reference to FIG. 14A, a cross-section of a module 10 is illustrated at a point after portions of the peripheral metallic structures 14A and 14B, which are associated with the component areas 16A and 16B, have been exposed through the overmold body 18. The exposing process results in openings 42 extending through the overmold body 18 to the peripheral metallic structures 14A and 14B. Prior to forming the different electromagnetic shields 20, a shield material mask 44, such as a plating mask or a spray mask, is applied in a manner that isolates the areas in which the respective elec-

tromagnetic shields 20 are formed. As illustrated in FIG. 14B, the shield material mask 44 is provided between the areas in which the respective electromagnetic shields 20 will be formed for the respective component areas 16A and 16B.

[0078] With reference to FIG. 14C, the electromagnetic shield material 46 necessary to form the respective electromagnetic shields 20 is applied over the portions of the overmold body 18 that are associated with the respective component areas 16A and 16B to form the electromagnetic shields 20. Notably, the electromagnetic shield material mask 44 prevents the electromagnetic shield material 46 associated with the different electromagnetic shields 20 from coming into contact with each other. As such, the electromagnetic shields 20 are formed about the component areas 16A and 16B over the respective portions of the overmold body 18, yet remain at least physically separate from one another. In a subsequent step, the electromagnetic shield material mask 44 may be removed, as illustrated in FIG. 14D. Notably, any number of component areas 16 may be provided on a module 10. The resultant shielding for these component areas 16 may be isolated or connected, wherein certain ones or groups of component areas 16 may be isolated from one another and other ones or groups of component areas 16 may be connected to one another. The desired shielding requirements for the electrical components provided in the respective component areas 16 should dictate such design decisions.

[0079] With many embodiments of the present invention, an exposing process is employed to remove a portion of the overmold body 18 (or like body) that is above the portion of the peripheral metallic structure to be exposed, such that the electromagnetic shield material 46 may be applied over the remaining portion of the overmold body 18 and into the openings 42 that are created over the exposed portions of the peripheral metallic structure. Various methods may be employed to create the openings 42 through the overmold body 18, either to or partially into the exposed portions of the peripheral metallic structure. These methods include sub-dicing (mechanical cutting), laser ablation, laser drilling, mechanical drilling, plasma etching, and the like. Notably, chemical-based etching techniques may generally be considered as cutting techniques. Further, a molding tool or form may be provided in association with forming the overmold body 18, wherein all or a portion of the openings 42 are reserved using the form.

[0080] With reference to FIGS. 15A and 15B, a module 10 is illustrated prior to employing an exposing process to create the openings 42, which are formed through the overmold body 18 to or into the portions of the peripheral metallic structure of the metallic layer grid 14 that are to be exposed. FIG. 15A is a cross-section of the module 10, and FIG. 15B is a top view of the module 10. As illustrated, the overmold body 18 covers the metallic layer grid 14 and the component area 16, as well as the remaining surface of the laminate structure.

[0081] With reference to FIGS. 15C and 15D, the module 10 has been subjected to a sub-dicing operation where a saw is used to form the openings 42 over substantially all of the peripheral metallic structure provided by the metallic layer grid 14. FIG. 15C is a cross-sectional view of the module 10, and FIG. 15D is a top view of the module 10. Since the sub-dicing step employs a saw, the openings 42 tend to take the form of trenches, which reside over the peripheral metallic structure of the metallic layer grid 14. In certain embodiments, these trenches may extend past the peripheral metallic structure, which runs immediately about the component area

16. Preferably, a depth-controlled cutting process is used to allow the saw to cut through the overmold body 18 to or slightly into the peripheral metallic structure, yet prevent the saw from cutting all the way through the peripheral metallic structure. With reference to FIGS. 15E and 15F, the electromagnetic shield 20 is formed over the overmold body 18 and into the openings 42 as described above. FIG. 15E provides a cross-sectional view of the module 10 and FIG. 15F provides a top view of the module 10, after the electromagnetic shield 20 is formed.

[0082] As noted, laser ablation may also be used to form the openings 42 through the overmold body 18. In general, laser ablation is the use of a laser to cut through the overmold body 18 in an analogous fashion to that provided during a sub-dicing process. One advantage of using a laser is the ability to more precisely control the location and depth of the cutting operation. Since the ability to precisely control the cutting depth when forming the openings 42 is important, the ability to immediately turn on or off a laser employed in a cutting process makes laser ablation particularly beneficial in forming the openings 42. Notably, certain laser ablation techniques result in trapezoidal trenches being formed for the openings 42, such as those illustrated in FIGS. 16A and 16B. FIG. 16A is a cross-section of a module 10 after the openings 42 have been formed using laser ablation, and FIG. 16B is a top view. FIGS. 16C and 16D, which are cross-sectional and top views of the module 10, respectively, illustrate the module 10 after formation of the electromagnetic shield 20 over the overmold body 18 and into the openings 42.

[0083] In addition, mechanical and laser drilling processes may be employed to form the openings 42. With reference to FIGS. 17A and 17B, which are cross-sectional and top views of the module 10, respectively, prior to formation of the electromagnetic shield 20, both types of openings 42 are depicted. The opening 42 formed by mechanical drilling is referenced as 42M, and the opening formed by laser drilling is referenced as 42L. Notably, it would be unlikely that both mechanical and laser drilling would be used to form the openings 42 for the same module 10. These differently formed openings 42M and 42L are merely illustrated to represent the different shapes that the openings 42M and 42L may take using the different drilling processes.

[0084] As illustrated, openings 42M or 42L (42M/L) are drilled through the overmold body 18 to or into the peripheral metallic structure of the metallic layer grid 14 about the component area 16. The size and number of openings 42M/L may be based on design criteria or shielding requirements. With reference to FIGS. 17C and 17D, the cross-sectional and top views, respectively, of the module 10 are illustrated after formation of the electromagnetic shield 20 over the overmold body 18 and into the drilled openings 42M or 42L.

[0085] FIGS. 18A-18F illustrate an embodiment wherein the openings 42 are created using a two-step process, which employs a form to initially create a form opening 48 in the overmold body 18 while the overmold body 18 is being formed. Reference is now made to FIGS. 18A and 18B, which are cross-sectional and top views, respectively, of a module 10 after an overmold body 18 has been formed. Notably, while the overmold body 18 was being formed, a form was used to create the form openings 48, which are represented as trenches over and about the component area 16 within the overmold body 18. After the overmold body 18 sets, the form is removed from the overmold body 18 to leave the form opening 48. The form opening 48 in this embodiment does

not extend all the way to the peripheral metallic structure provided by the metallic layer grid 14. Instead, a portion of the overmold body 18 remains between the bottom of the form opening 48 and the top of the peripheral metallic structure. Thus, to expose at least portions of the peripheral metallic structure, an additional step is necessary to cut or drill through the overmold body 18 from the bottom of the form opening 48 to the portions of the peripheral metallic structure that must be exposed. A laser or mechanical drilling or cutting process may be used to form the secondary opening 48' that extends from the bottom of the form opening 48 to or into the exposed portions of the peripheral metallic structure, as illustrated in FIGS. 18C and 18D, which are cross-sectional and top views, respectively.

[0086] With reference to FIGS. 18E and 18F, cross-sectional and top views, respectively, of the module 10 are provided after the electromagnetic shield 20 is formed over the overmold body 18 and into the form opening 48 and the secondary opening 48'. The form opening 48 and the secondary opening 48' create an overall opening 42. In all of the above embodiments, the electromagnetic shield 18 will extend from at least a portion of the top of the overmold body 18 through the openings 42 to the peripheral metallic structure.

[0087] In certain embodiments, the cutting or drilling operations used to form the openings 42 apply significant down force to the laminate 12. In many instances, the down force may cause the laminate 12 to flex downward, which may affect the depth of the openings 42. If the laminate 12 flexes too much, an opening 42 may not reach the peripheral metallic structure. As such, the resultant electromagnetic shield 20 will not come into electrical contact with the exposed portion of the peripheral metallic structure, which will affect the shielding performance of the electromagnetic shield 20. If the openings 42 extend too far, all or too much of the peripheral metallic structure may be removed by the cutting or drilling process, again affecting the electrical contact between the peripheral metallic structure and the electromagnetic shield, and in turn affecting the performance of the electromagnetic shield 20.

[0088] With reference to FIG. 19, a portion of a meta-module 24 is illustrated, wherein the outside edges of the meta-module 24 include a metal layer 50 and a masking material 52, such as a solder mask, on the underside of the laminate 12. The metal layer 50 and the masking material 52 effectively raise the bottom surface of the laminate 12 above a processing surface at the middle of the meta-module 24. Accordingly, down forces applied during cutting and drilling operations to the middle of the meta-module 24 will cause the laminate 12 to flex downward, which may affect the overall depth of the openings 42 that are created using the cutting or drilling process.

[0089] In one embodiment of the present invention, support structures 54 are provided along the bottom surface of the laminate 12 at locations that are substantially underneath at least part of the openings 42, as illustrated in FIG. 20. The support structures 54 may take various forms, such as rails, pillars, or grids. As illustrated, the support structures 54 are formed of a metal layer 50' and a masking material 52', in the same fashion as that used to form metal layer 50 and masking material 52. The support structures 54 need not be continuously provided underneath the openings 42. For example, as illustrated in FIG. 21, the support structures 54 may be positioned at the junctions of openings 42 that form a grid. As

illustrated, the trench-like openings 42 will intersect one another, and beneath the intersections of these trench-like openings 42 will lie a support structure 54 on the opposite (bottom) side of the laminate 12. Those skilled in the art will recognize various ways in which support structures 54 may be constructed.

**[0090]** The purpose of the support structure 54 is to provide a support mechanism to counter the downward forces that are applied to the laminate 12 during cutting and drilling operations. Providing the support structures 54 prevents or significantly reduces the extent that the laminate 12 flexes during the cutting and drilling processes, and as such, affords more consistent and precise cutting and drilling operations. As a result, the openings 42 are more consistent, such that less of the overmold material is left on those portions of the peripheral metallic structure that should be exposed, and at the same time, ensuring that those same portions of the peripheral metallic structure are not destroyed by cutting or drilling completely through them. Stabilization of the laminate 12 using the support structures 54 has proven to significantly reduce the number of rejects due to cutting or drilling too deeply, wherein the peripheral metallic structure is destroyed, or cutting or drilling too shallowly, wherein overmold material is left on the surface of the peripheral metallic structure.

**[0091]** As noted, the laminate 12, and thus a meta-module 24, is carried on a processing platform during processing. For certain embodiments, it is beneficial to protect the bottom surface of the laminate 12, especially those portions corresponding to a sub-module 22 or module 10, from various gases or liquids, such as plasma etching and plating materials that are used to process the top surface of the meta-module 24. With reference to FIGS. 22 and 23, one embodiment of the invention incorporates a seal structure 56, which effectively provides a seal between the bottom surface of the laminate 12 and a top surface of a carrier media 62 on which the laminate 12 is carried during processing. The carrier media 62 may be a tape having an adhesive on its top surface. In a preferred embodiment, the seal structure 56 is provided at least in part by a metal ring 58 that is formed around an area to be protected on the bottom of the laminate 12.

**[0092]** As illustrated in FIG. 22, the seal structure 56 may be provided in association with each meta-module 24, and effectively provide a continuous ring about the outside periphery of the meta-module 24. In other words, the seal structure 56 will extend about an area on the bottom surface of the laminate 12 that corresponds to all of the component areas 16 for one or more meta-modules 24. The seal structure 56 may be made of the same material used to form the support structure 54. Regardless of material, the seal structure 56 may include a metal ring 58 formed on the bottom of the laminate 12, as illustrated in FIG. 23. The seal structure 56 may also include a masking material 60, such as a solder mask, that resides on the bottom surface of the metal ring 58. Whatever represents the bottom of the seal structure 56 will preferably be adhered to the top surface of the carrier media 62 sufficiently to prevent gases or liquids used during formation of the sub-modules 22 or modules 10 to substantially leak into the area beneath the laminate 12 and within the seal structure 56. This is particularly beneficial when numerous contact pads reside on the bottom surface of the laminate 12 and may be damaged, shorted, or the like if exposed to certain liquids or gases used during fabrication. The seal structure 56 need not form a complete ring. As an alternative, a spiral shape or substantially closed shape may suffice.

**[0093]** As noted above, caution should be taken to ensure that the portions of the peripheral metallic structure to be exposed are sufficiently exposed, yet not destroyed, during cutting or drilling processes to form the openings 42. In many embodiments, the metallic layer grid 14 used to form the peripheral metallic structures for the various sub-modules 22 or modules 10 may be relatively thin and formed from one of the upper metal layers of the laminate 12. As noted above, the support structures 54 may be used to maintain consistent cutting and drilling processes. In lieu of or in addition to the support structures 54, steps may be taken to increase the thickness of any metallic structure, including the peripheral metallic structures formed from the metallic layer grid 14 in an effort to reduce the precision necessary to cut or drill through the overmold body 18 to or into the peripheral metallic structure to be exposed, without drilling completely through the peripheral metallic structure.

**[0094]** With reference to FIGS. 24A-24E, an exemplary technique is provided to effectively increase the thickness of the metallic layer grid 14, and thus minimize the precision necessary to effectively create the openings 42 through the overmold body 18 to the peripheral metallic structures of the metallic layer grid 14. Initially, a first metal grid 64 is formed from a top metal layer of the laminate 12 using an appropriate etching process, as illustrated in FIG. 24A. Subsequently, one or more plating layers 66 are formed on top of the first metal grid 64 to form the metallic layer grid 14 using appropriate masking and plating processes, as illustrated in FIG. 24B. As described above, the overmold body 18 is formed over the peripheral metallic structures, and openings 42 are cut or drilled to or into the peripheral metallic structures, as illustrated in FIGS. 24C and 24D, respectively.

**[0095]** With the increased thickness of the metallic layer grid 14, the cutting or drilling process may be configured to err on drilling deeper into the metallic layer grid 14, without excessive concern for drilling completely through the metallic layer grid 14. After the openings 42 are formed, the electromagnetic shield 20 may be formed over the overmold body 18 and into the openings 42 to the exposed portion of the peripheral metallic structure provided by the metallic layer grid 14, as illustrated in FIG. 24E. Those skilled in the art will recognize various plating techniques to employ for providing the plating layer 66. As noted, multiple plating layers may be employed. Further, the same plating process used to form the electromagnetic shield 20 may be used to form the plating layer 66.

**[0096]** From the above, plating may be used to increase the relative thickness of the overall metallic structure, such that the cutting or drilling process is less likely to significantly damage the metallic structure. With the plating technique, a metallic plating layer is placed over a base metallic portion, which may reside on or in the laminate 12. This base metallic portion may be placed over additional metallic structures that are formed within the laminate 12. These metallic structures that are formed within the laminate 12 may include metallic vias, which are effectively holes extending into or through the laminate 12 that are subsequently filled with metal. As such, the metallic vias and the base metallic portion together form a metallic structure that can readily withstand the cutting or drilling process without adversely affecting shielding performance. Notably, other metallic structures may be placed beneath and in contact with the base metallic portion to effectively thicken the metallic structure to which the electromagnetic shield 20 is ultimately connected. These techniques, as



well as the techniques that follow, may be employed regardless of the form or shape of the metallic structure. For example, these thickening techniques may be employed for peripheral metallic structures that are provided in part by the metallic layer grid 14, wherein the metallic layer grid 14 forms the base metallic portion. Accordingly, the metallic layer grid 14 may be plated, or alternatively, placed over and in contact with vias within the laminate 12.

[0097] Plating and the use of vias are not the only techniques for increasing the thickness of the metallic layer grid 14. As illustrated in FIGS. 25A-25E, surface mount structures 68 may be placed on the first metal grid 64 during the same processing in which surface mount components are provided in the component areas 16. The surface mount structures 68 are preferably metallic and conductive. With reference to FIG. 25A, the first metal grid 64 is formed on the top surface of the laminate 12 as described above. During the surface mount process, the surface mount structures 68 are placed on the first metal grid 64, as illustrated in FIG. 25B, and then the overmold body 18 is applied, as illustrated in FIG. 25C. Notably, the surface mount structures 68 do not extend to the top of the overmold body 18. As such, a cutting or drilling process is employed to form the openings 42 that extend to or into the surface mount structures 68, as illustrated in FIG. 25D. The electromagnetic shield 20 is then formed over the overmold body 18 and to the exposed ones or portions of the surface mount structures 68 through the openings 42, as illustrated in FIG. 25E.

[0098] In an alternative embodiment, which is illustrated in FIGS. 26A-26D, the surface mount structures 68 may be sized such that the top surface of the surface mount structure 68 is flush with the top surface of the overmold body 18. Again, the first metal grid 64 is formed on the top surface of the laminate 12, as illustrated in FIG. 26A, and then the surface mount structures 68 are formed on the first metal grid 64 to form the metallic layer grid 14, as illustrated in FIG. 26B. When the overmold body 18 is applied in FIG. 26C, the surface mount structures 68 extend to the top surface of the overmold body 18 and are exposed. As such, there is no need for a cutting or drilling step to form an opening 42. In effect, the cutting or drilling process is eliminated, and the electromagnetic shield 20 may be formed along the top surface of the overmold body 18 and the surface mount structures 68, as illustrated in FIG. 26D. Although a surface mount structure 68 is illustrated, those skilled in the art will recognize that other plating or layering techniques may be used to effectively build the height of the metallic layer grid 14 to a point that will be flush with the top surface of the overmold body 18 in an effort to avoid the need to create the openings 42 extending to the top surface of the metallic layer grid 14 prior to forming the electromagnetic shield 20.

[0099] Regardless of the height of the surface mount structures 68, various structural configurations may be employed when building the enhanced-height metallic layer grid 14. With reference to FIG. 27A, the surface mount structure 68 may be a solid ring, which resides on a portion of the first metal grid 64 to form the metallic layer grid 14. Alternatively, and as illustrated in FIG. 27B, numerous surface mount structures 68 may be positioned on the first metal grid 64 to form the metallic layer grid 14. Although the first metal grid 64 is shown as being continuous, it may be created to correspond to the configurations of the surface mount structure or structures 68. In FIG. 27B, the surface mount structures 68 are shown to have a rectangular form factor, while those illustrated in FIG.

27C are shown to have a round or oval form factor. Further, metallic structures of any type may be applied in a similar fashion outside of a typical surface mount process.

[0100] With the above embodiments, the metallic layer grid 14 may be a multi-component structure. Further, in many of these embodiments, the base structure was the first metal grid 64, which may be continuous or discontinuous about the component areas 16 to be shielded. An alternative to these embodiments is provided in FIG. 28A. As illustrated, the metallic layer grid 14, which is not specifically referenced, is formed from a collection of metallic studs 70, which are formed or placed along the top surface of the laminate 12. FIG. 28A illustrates a single module 10 having three component areas 16A, 16B, and 16C; however, those skilled in the art will recognize that the arrangement of the metallic studs 70 about the overall periphery of the illustrated laminate 12 as well as about the component areas 16A and 16B, may be repeated in a grid-like fashion throughout a corresponding meta-module 24 for the different modules 10. In this example, components 72 and 74 are illustrated as being in component areas 16A and 16B, respectively. Although not illustrated, component area 16C may also include electronic components. During the cutting or drilling process to expose the metallic layer grid 14 through the overmold body 18, trenches or holes are cut through the overmold body 18 to or into the metallic studs 70 to be exposed. In essence, these metallic studs 70 form the peripheral metallic structure that surrounds one or more component areas 16A, 16B, 16C. Component areas 16A, 16B, 16C may each have its own electromagnetic shield 20. Notably, the metal studs 70 are formed directly on the laminate 12, and not on a metal trace or layer, such as the first metal grid 64. Instead, traces or vias within the laminate 12 may be used to connect all or select ones of the metallic studs 70 to an appropriate node, such as a ground plane, for shielding purposes.

[0101] With reference to FIG. 28B, metallic studs 70 are again used to provide the metallic layer grid 14. However, the metallic studs 70 are placed on a peripheral metal trace 76. As such, various points along the metal trace 76 may be connected through additional traces or vias to a node, such as a ground plane, for shielding purposes. In this embodiment, the metallic layer grid 14 will include the metal traces 76 for multiple modules 10 and the metallic studs 70 that reside thereon. The cutting or drilling process employed to expose the metallic layer grid 14 is configured to cut or drill to or into the metallic studs 70 that are to be exposed. In either of the embodiments illustrated in FIG. 28A or 28B, once the selected metallic studs 70 are exposed through the overmold body 18, the electromagnetic shield 20 may be applied over the overmold body 18 and into the openings 42 to the exposed metallic studs 70. From the above, those skilled in the art will recognize various ways in which to implement the metallic grid layer 14, and thus the peripheral metallic structures that are formed about all or a portion of the component area 16 to be shielded according to the present invention.

[0102] Notably, any metallic structure for a component area 16 may be continuous or segmented along one or more sides of the component area 16. These metallic structures need not extend completely or even substantially about a periphery of a component area 16. However, better shielding performance is generally associated with more contact with more extensive peripheral metallic structures.

[0103] The shielding techniques of the present invention may be extended to provide functionality in addition to elec-

tromagnetic shielding. For example, various components residing in a component area 16 may be thermally connected to the electromagnetic shield 20, wherein the electromagnetic shield will provide a thermal path to a defined location or act as a heat sink itself. With reference to FIG. 29A, a module 10 is provided with an electromagnetic shield 20 according to one embodiment of the present invention. As illustrated, a component area 16 (not referenced) includes three electronic components 78, 80, and 82. The electronic components 78 and 82 reside over and are electrically and thermally coupled to multiple thermal vias 84, which are configured to dissipate heat away from the electronic components 78 and 82 through the laminate 12 to a structure on which the module 10 will ultimately be mounted. For this example, assume that electronic component 80 does not need such thermal vias 84. Also illustrated in FIG. 29A is an electromagnetic shield 20, which extends over the overmold body 18 and down to shielding vias 86, which are generally coupled to a ground plane within the laminate 12 or on the structure to which the module 10 will ultimately be mounted. In this embodiment, the electromagnetic shield 20 will generally not assist in dissipating heat generated by the electronic components 78, 80, 82.

[0104] With reference to FIG. 29B, the module 10 that was illustrated in FIG. 29A has been modified such that the electromagnetic shield 20 is thermally, and perhaps electrically, coupled to the electronic components 78 and 82. In this embodiment, significant portions of the overmold body 18 are exposed such that application of the electromagnetic shield 20 will result in the electromagnetic shield 20 extending to the top surfaces of the electronic components 78 and 82. Electronic component 82 relies primarily on the electromagnetic shield 20 for heat dissipation, as the associated thermal vias 84 are not present. However, thermal vias 84 are provided for the electronic component 78. As such, electronic component 78 may take advantage of thermal vias 84 and the electromagnetic shield 20 to dissipate heat from both sides of the electronic component 78. The heat dissipated through the electromagnetic shield 20 may be primarily dissipated through the primary structure of the electromagnetic shield 20 or passed back through the laminate 12 through the shielding vias 86. In either case, the shielding vias 86 may also provide an electrical path to ground for the electromagnetic shield 20, and perhaps the electronic component 78 as well.

[0105] Those skilled in the art will recognize the various options for using the electromagnetic shield 20 for thermal and electrical conduction. Formation of the openings above the electronic components 78 and 82 may be provided by cutting or drilling through the overmold body 18, after the overmold body 18 has been applied. As such, the techniques used to provide the openings 42 may be used to remove the portion of the overmold body 18 above the electronic components 78 and 82. Alternatively, masking techniques may be employed to prevent the overmold body 18 from being formed over these electronic components 78 and 82.

[0106] The module 10 as illustrated in FIG. 29C is substantially similar to that illustrated in FIG. 29B, with the exception that the electromagnetic shield 20 does not extend to the electronic component 78. Instead, the electromagnetic shield 20 only extends to the electronic component 82. The thermal vias 84 are only used in association with the electronic component 78, and not the electronic component 82. Accordingly, different electronic components 78 and 82 may employ different thermal paths for heat dissipation, where at least one of the thermal paths includes the electromagnetic shield 20,

which is also used for electromagnetic shielding. Again, the electromagnetic shield 20 may also provide an electrical path to ground or other node for the electronic component 82.

[0107] In FIGS. 29B and 29C, the portions of the electromagnetic shield 20 that reside over the electronic components 78 and 82 extend through the overmold body 18 to the electronic components 78 and 82. The electronic components 78 and 82 do not extend above the laminate 12 as far as the overmold body 18 extends above the laminate 12. As a result, openings must be provided above the electronic components 78 and 82 in which the electromagnetic shield 20 extends downward to the electronic components 78 and 82. In an alternative embodiment such as that illustrated in FIG. 29D, the electronic components 78 and 82 may be of the same height as the overmold body 18, such that they extend above the laminate 12 to the same extent as the overmold body 18. Accordingly, the electronic components 78 and 82 do not require openings above them within the overmold body 18 to come into contact with the electromagnetic shield 20. If the electronic components 78 and 82 are not the same height as the resulting overmold body 18, various techniques may be used to effectively extend the height of the electronic components 78 and 82 with thermally conductive material to ensure contact with the electromagnetic shield 20.

[0108] In many instances, circuitry within a shielded area may generate electromagnetic fields that impact other circuitry within the same shielded area. When the circuitry creating the electromagnetic fields cannot be separately shielded from circuitry that is sensitive to electromagnetic fields, the overall performance of the circuitry is negatively impacted. In one embodiment of the present invention, field barrier structures 88 are formed inside the electromagnetic shield 20 in an effort to attenuate electromagnetic fields that occur inside the electromagnetic shield 20, as illustrated in FIG. 30A. The field barrier structures 88 may take on various shapes or forms, but will preferably extend downward from the electromagnetic shield 20 to or toward the laminate 12 through the overmold body 18 and perhaps any circuitry residing in the component areas 16. As illustrated, the field barrier structures 88 extend all the way from the electromagnetic shield 20 to the laminate 12, and in particular to field barrier vias 90. The field barrier vias 90 are coupled to the field barrier structures 88 directly or via an appropriate trace, and extend through all or a portion of the laminate 12 to a ground plane 92, which is illustrated in the middle of the laminate 12, but may reside anywhere within the laminate 12 or on the bottom surface of the laminate 12. Notably, shield vias 94 may extend between the ground plane 92 and the metallic layer grid 14, which provides the exposed portion of the metallic layer structure. Accordingly, the electromagnetic shield 20 may be connected to the ground plane 92 through the metallic layer grid 14 and the shield vias 94, while the field barrier structures 88 are connected to the ground plane 92 either through the field barrier vias 90 or through the electromagnetic shield 20, the metallic layer grid 14, and the shield vias 94. Notably, if the field barrier structures 88 do not extend all the way to the laminate 12, an electrical connection to the electromagnetic shield 20 is provided through the metallic layer grid 14 and the shield vias 94 to the ground plane 92.

[0109] With reference to FIG. 30B, the field barrier structures 88 may be provided anywhere within the component area 16 of the module 10. In the illustrated embodiment, electronic components 96A, 96B, and 96C reside in the component area 16 and cylindrical field barrier structures 88 are

positioned in a staggered manner within the component area **16**. The dashed lines in FIG. **30B** represent elements residing under the continuous electromagnetic shield **20** that covers most, if not all, of the module **10** in the illustrated embodiment.

**[0110]** Although FIGS. **30A** and **30B** illustrate substantially cylindrical configurations of the field barrier structures **88**, those skilled in the art will recognize that the field barrier structures **88** may take virtually any shape that may be oriented among the electronic components **96A**, **96B**, **96C** and reside within the component area **16**, which is covered by the electromagnetic shield **20**. For example, the field barrier structures **88** may form straight, angled, or curved walls or like elements within the electromagnetic shield **20**. Again, the field barrier structures **88** may, but need not, extend completely between the electromagnetic shield **20** to the top surface of the laminate **12**. The field barrier structures **88** may also extend from the electromagnetic shield **20** through the overmold body **18** into contact with a top portion of an electronic component **96A**, **96B**, **96C** or simply to a point over these components or the surface of the laminate **12**, without coming into contact with anything other than the overmold body **18** and the electromagnetic shield **20**.

**[0111]** In one embodiment, the field barrier structures **88** are integrally formed along with the electromagnetic shield **20**. In particular, prior to applying the electromagnetic shield **20**, openings (not referenced) for the field barrier structures **88** are formed within the overmold body **18** when portions of the metallic layer grid **14** are being exposed. Preferably, the same cutting or drilling process used to expose the peripheral metallic structure of the metallic layer grid **14** is used to create the openings for the field barrier structures **88**. After any cleaning or roughening steps, the spraying or plating processes for applying the electromagnetic shield material for the electromagnetic shield **20** will also operate to line or fill the openings to create the field barrier structures **88** along with creating the electromagnetic shield **20**. As such, the field barrier structures **88** and the electromagnetic shield **20** may form a single uniform structure, wherein the field barrier structures **88** are electrically, thermally, and physically connected to the electromagnetic shield **20**. However, the field barrier structures **88** need not be formed using the same process or at the same time as the electromagnetic shield **20**. Different processes and different materials may be used to form the field barrier structures **88** and the electromagnetic shield **20**.

**[0112]** Preferably, the field barrier structures **88** are positioned over or within the component area **16** in such a way as to attenuate electromagnetic fields emanating from one or more of the electronic components **96A**, **96B**, **96C**. Simulation or experimentation may be used for given embodiments, to determine the position, shape, orientation, and number of field barrier structures **88** to achieve desired operational characteristics.

**[0113]** Those skilled in the art will recognize improvements and modifications to the preferred embodiments of the present invention. All such improvements and modifications are considered within the scope of the concepts disclosed herein and the claims that follow. In the claims, use of the term "certain" in association with members of a group shall mean at least one of the members of the group. All members of the group may, but need not be, considered "certain" members. Further, wherein a plurality of members of a group has a plurality of elements, only certain members need to have at

least one element. Although acceptable, each of the certain members need not have more than one element.

What is claimed is:

1. A method of manufacturing a module comprising:
  - providing an electronic meta-module comprising a substrate, a plurality of component areas on a surface of the substrate for a plurality of modules, and a body formed from a dielectric material that covers the plurality of component areas, wherein certain component areas of the plurality of component areas are associated with metallic structures that are covered by the body, each of the metallic structures comprising:
    - a bottom metallic element on the surface of the substrate; and
    - a top metallic element above the first metallic element;
      - exposing at least a portion of the top metallic element of the metallic structures associated with the certain component areas through the body to provide a plurality of exposed metallic structures; and
  - applying an electromagnetic shield material over at least portions of an exterior surface of the body for each of the certain component areas and on the plurality of exposed metallic structures to form electromagnetic shields over the certain component areas.
2. The method of claim 1 wherein exposing the at least a portion of the metallic structures associated with the certain component areas through the body comprises at least one of cutting and drilling through the body to the top metallic element for each of the exposed metallic structures.
3. The method of claim 2 wherein exposing the at least a portion of the metallic structures associated with the certain component areas through the body comprises at least one of cutting and drilling into the top metallic element for each of the exposed metallic structures.
4. The method of claim 3 wherein exposing the at least a portion of the metallic structures associated with the certain component areas through the body comprises at least one of cutting and drilling into the top metallic element without cutting or drilling through the bottom metallic element for each of the exposed metallic structures.
5. The method of claim 1 wherein the top metallic element is located directly on the bottom metallic element.
6. The method of claim 1 wherein the bottom metallic element for each of the metallic structures is formed from a metal layer on the surface of the substrate.
7. The method of claim 1 further comprising forming the top metallic element using a plating process.
8. The method of claim 7 wherein the top metallic element is plated directly on the bottom metallic element using the plating process.
9. The method of claim 1 wherein the top metallic element comprises a metallic body, and further comprising placing the metallic body on the bottom metal element for each of the metallic structures.
10. The method of claim 1 wherein the bottom metal element comprises a continuous metal trace for each of the metallic structures.
11. The method of claim 10 wherein a plurality of metallic bodies are placed on the continuous metal trace for each of the metallic structures.
12. The method of claim 1 further comprising separating the plurality of modules of the electronic meta-module from

each other, wherein each module comprises at least one of the certain component areas having one of the electromagnetic shields.

**13.** The method of claim **1** further comprising exposing the exterior surface of the body to a reactive process gas to remove contaminants on the exterior surface of the body prior to applying the electromagnetic shield material.

**14.** The method of claim **1** further comprising roughening the exterior surface of the body prior to applying the electromagnetic shield material.

**15.** The method of claim **1** wherein applying the electromagnetic shield material comprises plating at least one conductive material over the at least portions of the exterior surface of the body and on the exposed metallic elements.

**16.** The method of claim **15** wherein plating the at least one conductive material comprises plating a first layer with an electroless plating process and plating a second layer with an electrolytic plating process.

**17.** The method of claim **1** wherein the body is formed by uniformly covering the component areas for the plurality of modules with the dielectric material, such that the body is

initially a single, continuous element that covers all of the plurality of component areas prior to exposing the exposed metallic structures.

**18.** The method of claim **1** wherein the metallic structures extend substantially about a periphery of each of the certain component areas.

**19.** The method of claim **18** wherein the bottom metallic element for each of the metallic structures comprises a continuous metal trace on the surface of the substrate and extending substantially about the periphery of each of the certain component areas.

**20.** The method of claim **18** wherein the bottom metallic element for each of the metallic structures comprises a discontinuous metal trace on the surface of the substrate and extending substantially about the periphery of each of the certain component areas.

**21.** The method of claim **18** wherein each of the metallic structures comprises a series of segments on the surface of the substrate and extending substantially about the periphery of each of the certain component areas.

\* \* \* \* \*