

- [54] STORAGE DEVICE FOR FLAT RECORDING MEDIA
- [75] Inventor: Peter Ackeret, Kusnacht, Switzerland
- [73] Assignee: IDN Inventions and Development of Novelties AG, Chur, Switzerland
- [21] Appl. No.: 937,211
- [22] Filed: Dec. 3, 1986

4,082,386	4/1978	Beasley, Jr.	206/804
4,087,145	5/1978	Weaver	312/319
4,113,091	9/1978	Ackeret	206/387
4,162,112	7/1979	Konkler	312/15
4,191,292	3/1980	Schweizer	206/387
4,191,292	3/1980	Schweizer	206/387
4,275,943	6/1981	Gelerdi et al.	312/319
4,293,266	10/1981	St. Lawrence et al.	206/387
4,387,802	6/1983	Shearing et al.	206/444
4,399,913	8/1983	Gerlardi et al.	206/387
4,444,314	4/1984	Jacobsson	206/311

Related U.S. Patent Documents

Reissue of:

- [64] Patent No.: 4,493,417
- Issued: Jan. 15, 1985
- Appl. No.: 565,120
- Filed: Dec. 23, 1983

[30] Foreign Application Priority Data

- Dec. 23, 1982 [DE] Fed. Rep. of Germany 3247796
- [51] Int. Cl.⁴ B65D 85/672
- [52] U.S. Cl. 206/387; 206/45.13; 206/311; 206/444; 221/247; 221/271; 312/12; 312/15; 312/319
- [58] Field of Search 206/387, 444, 311, 379, 206/45, 45.13; 312/8-15, 111, 107, 319; 221/186, 188, 209, 271, 247, 249, 87

References Cited

U.S. PATENT DOCUMENTS

Re. 30,184	1/1980	Ackeret	206/387
2,261,806	11/1941	Hills	312/10
2,269,637	1/1942	Polkosnik	206/379
2,278,529	4/1942	Beder	312/12
2,589,593	3/1952	Anderson et al.	206/45.13
2,720,438	10/1955	Musick	312/12
2,804,197	8/1957	Popkess et al.	206/45.13
3,561,004	2/1971	Kozu et al.	206/1
3,582,168	6/1971	Bian	312/19
3,677,396	7/1972	Staar	206/1 R
3,811,745	5/1974	Cylke	312/13
3,836,222	9/1974	Kuntze	312/319
3,866,990	2/1975	McRae	312/15
3,893,585	7/1975	Morrison et al.	220/22.6
3,899,229	8/1975	Ackeret	312/319
3,904,259	9/1975	Hoffmann et al.	312/111
3,926,310	12/1975	Ackeret	206/387
3,994,550	11/1976	Ackeret	312/319
3,994,551	11/1976	Ackeret	312/319
3,995,737	12/1976	Ackeret	206/387
3,995,921	12/1976	Ackeret	312/12
4,024,954	5/1977	Staar	206/387
4,046,255	9/1977	Ackeret	206/387

FOREIGN PATENT DOCUMENTS

344416	11/1977	Austria	.
86275	8/1983	European Pat. Off.	.
87765	9/1983	European Pat. Off.	.
1343653	10/1963	France	.
2127857	10/1972	France	.
1141092	12/1962	Fed. Rep. of Germany	.
1958291	4/1967	Fed. Rep. of Germany	.
1797278	8/1971	Fed. Rep. of Germany	.
7435482	5/1972	Fed. Rep. of Germany	.
2149690	4/1973	Fed. Rep. of Germany	.
2248408	1/1974	Fed. Rep. of Germany	.
2307410	8/1974	Fed. Rep. of Germany	.
2914415	6/1980	Fed. Rep. of Germany	.
2917806	11/1980	Fed. Rep. of Germany	.
3015749	10/1981	Fed. Rep. of Germany	.
3106511	9/1982	Fed. Rep. of Germany	.
2077234	11/1983	United Kingdom	.

OTHER PUBLICATIONS

Ackeret U.S. patent application Ser. No. 456,392, filed Jan. 7, 1983.

Primary Examiner—Stephen Marcus
 Assistant Examiner—Bryon Gehman
 Attorney, Agent, or Firm—Douglas N. Larson

[57] ABSTRACT

A storage device for flat recording media, e.g. compact discs, is disclosed. The device comprises a housing and a slider member having a base portion and front wall that covers the open front face of the housing when the slider member is inserted. A lifting element, which is transported out of the housing by means of the slider member, is provided for supporting the recording media in a position for easy insertion and removal.

65 Claims, 11 Drawing Sheets

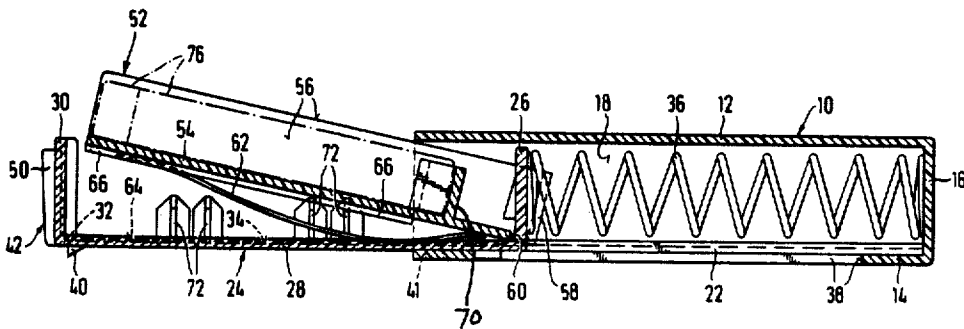

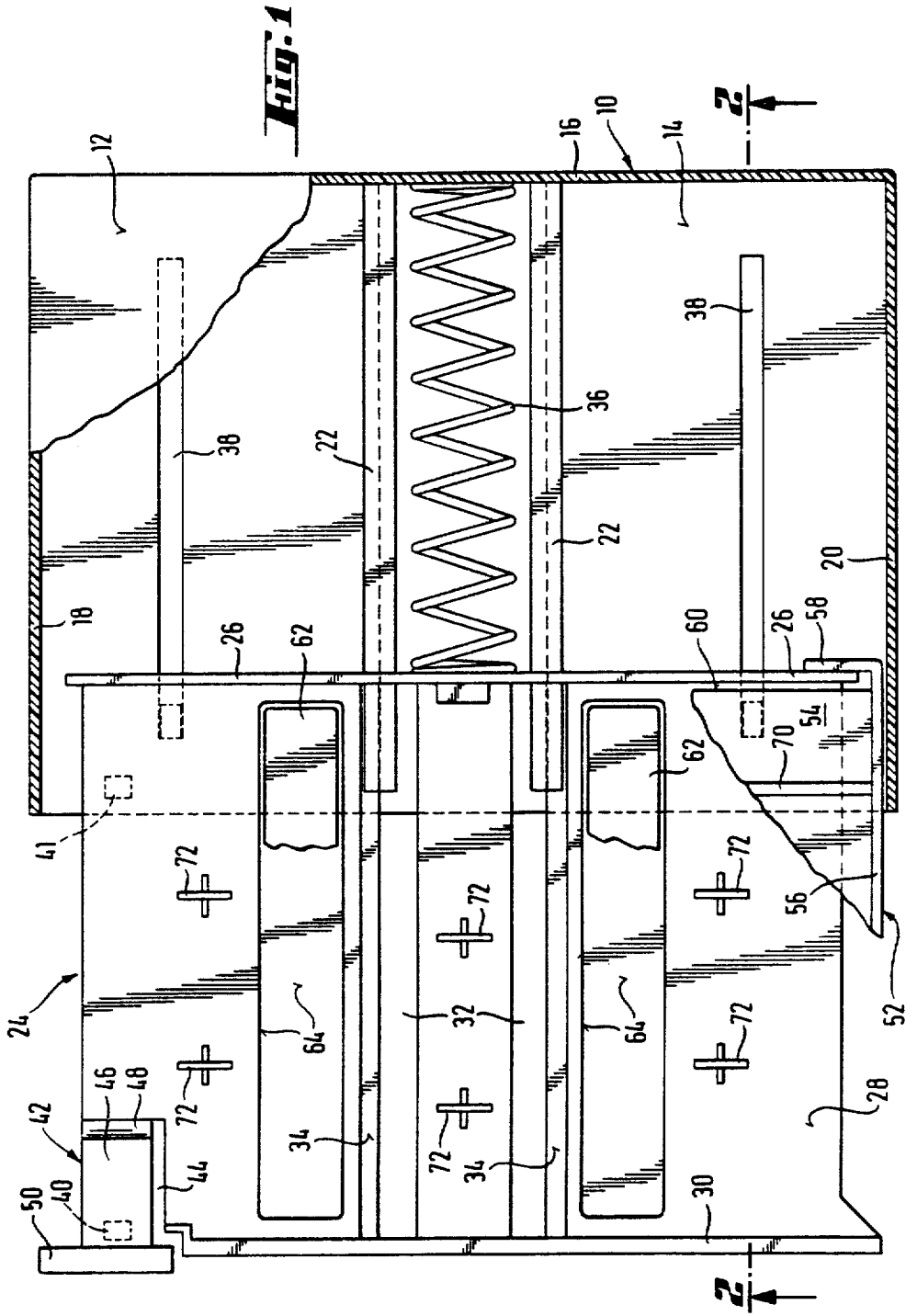

Fig. 2

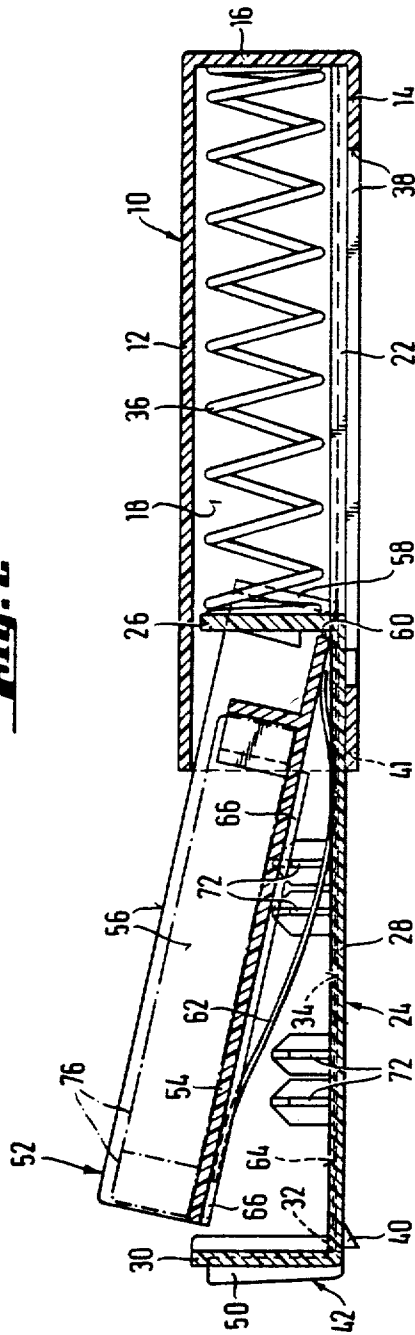
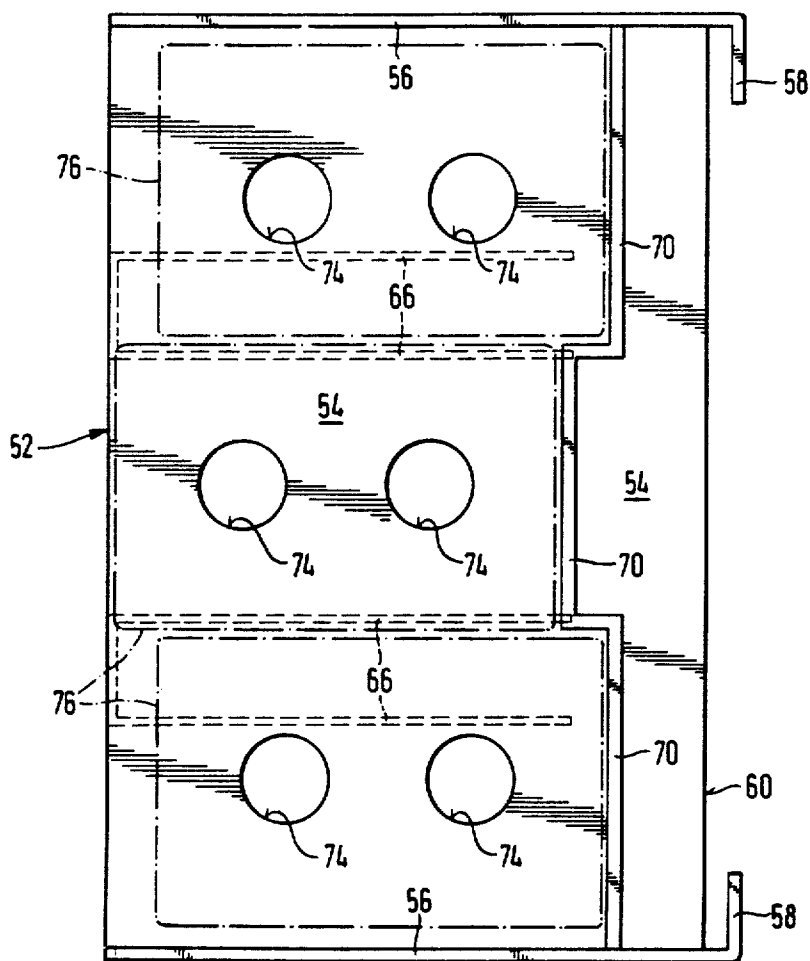

Fig. 3



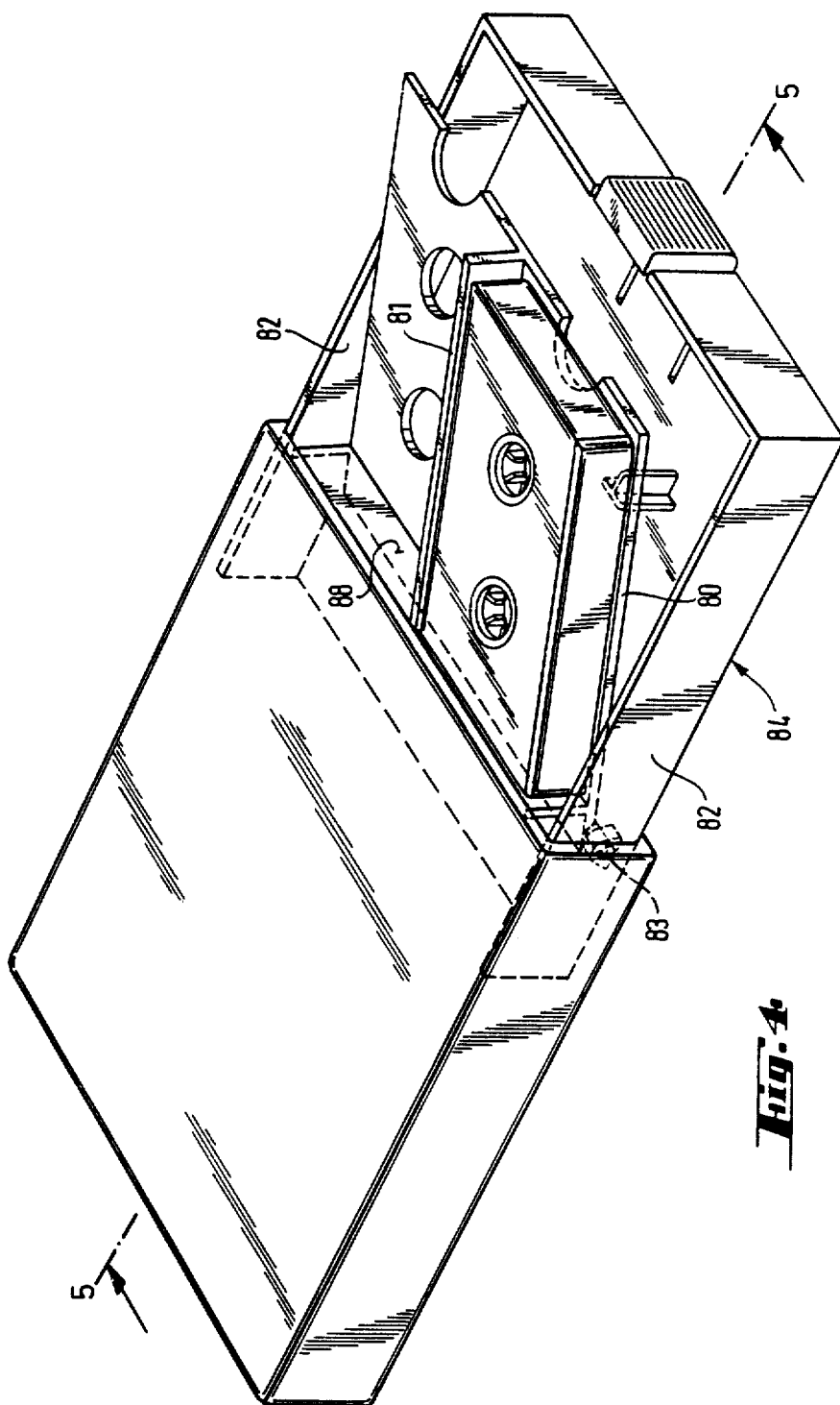
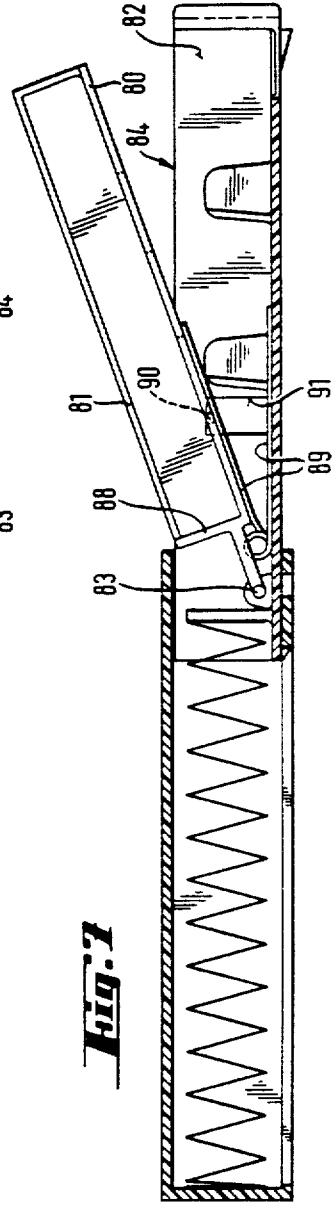
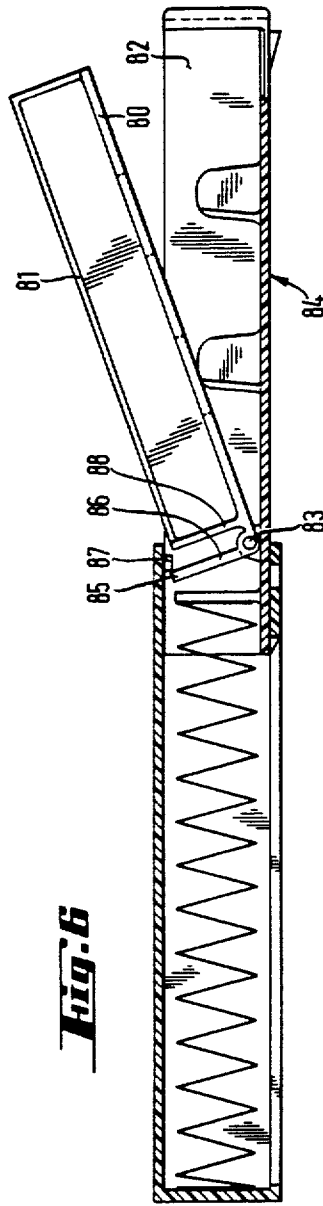
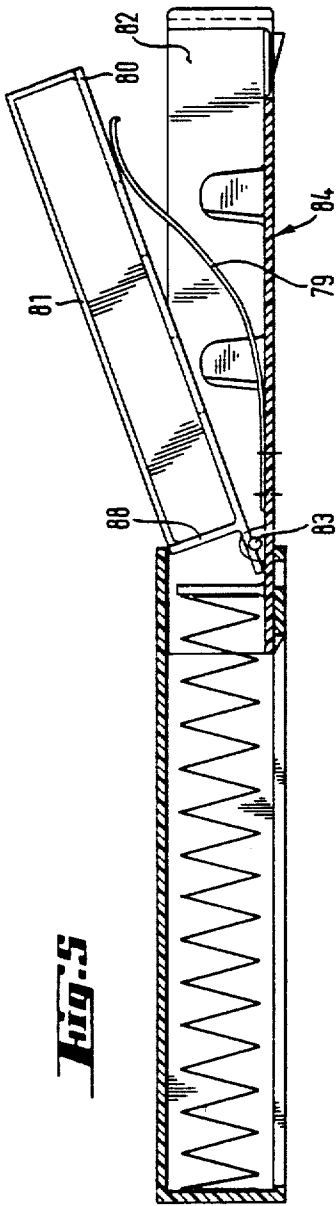
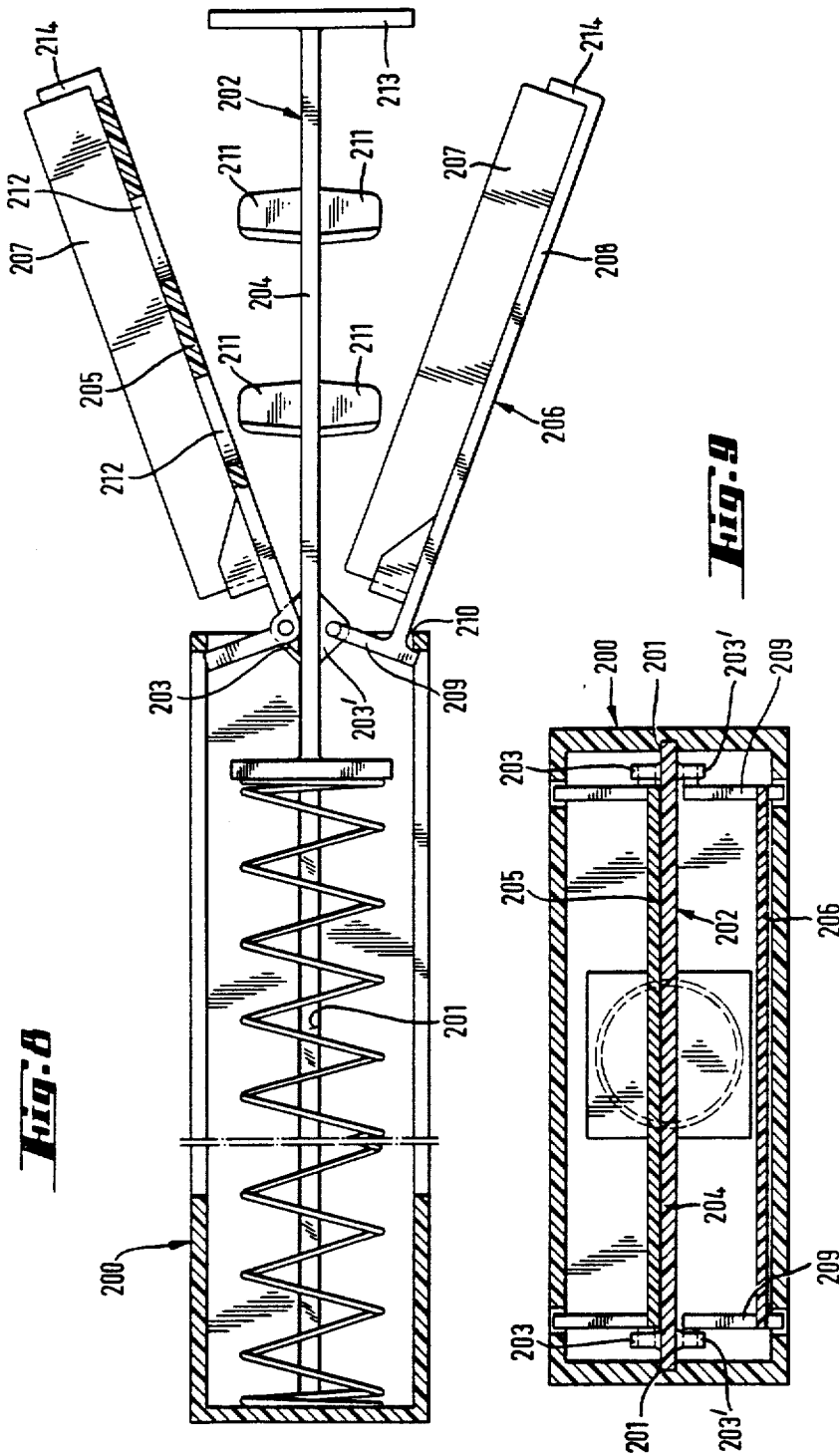

Fig. 4





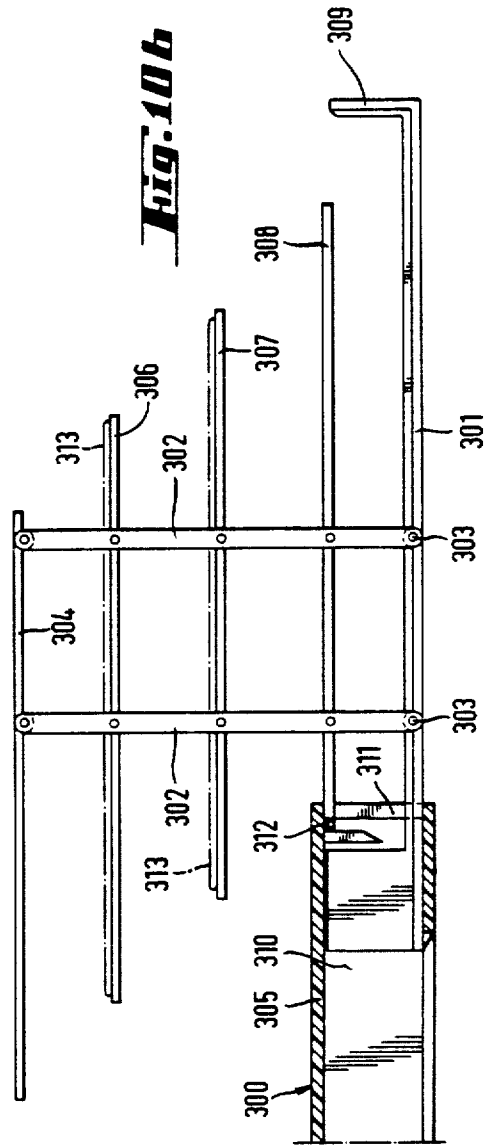
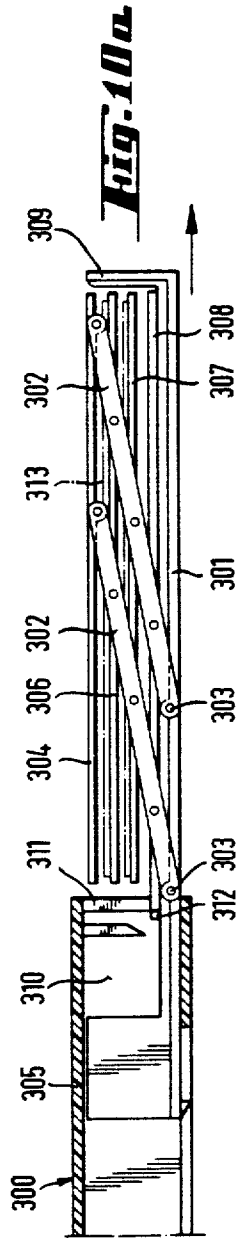
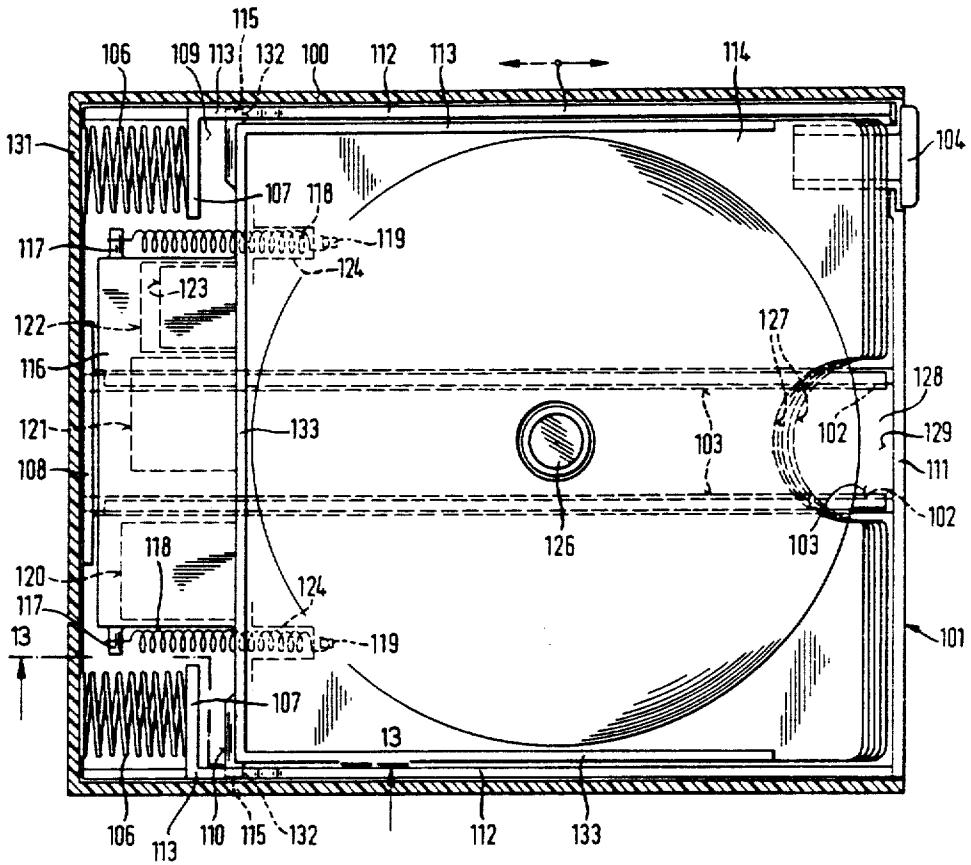

Fig. 11



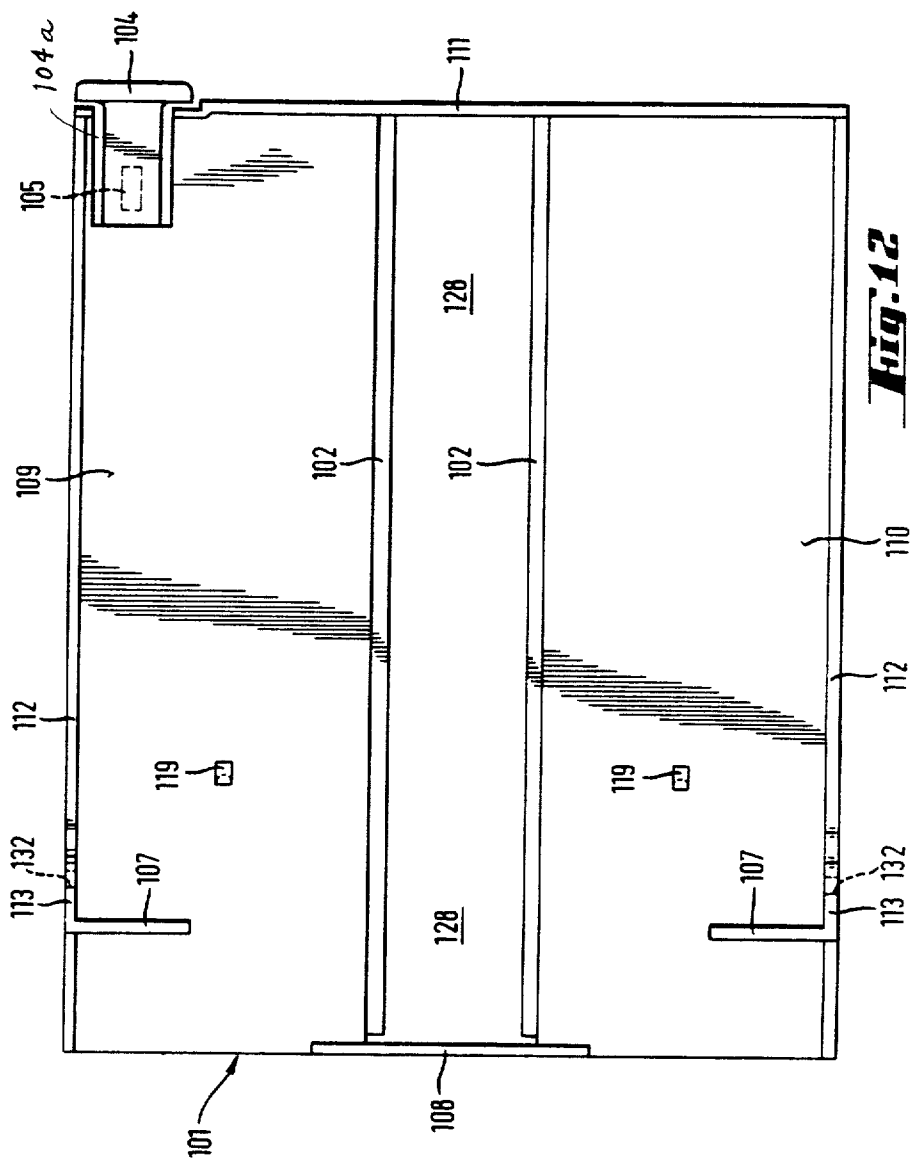

Fig. 13

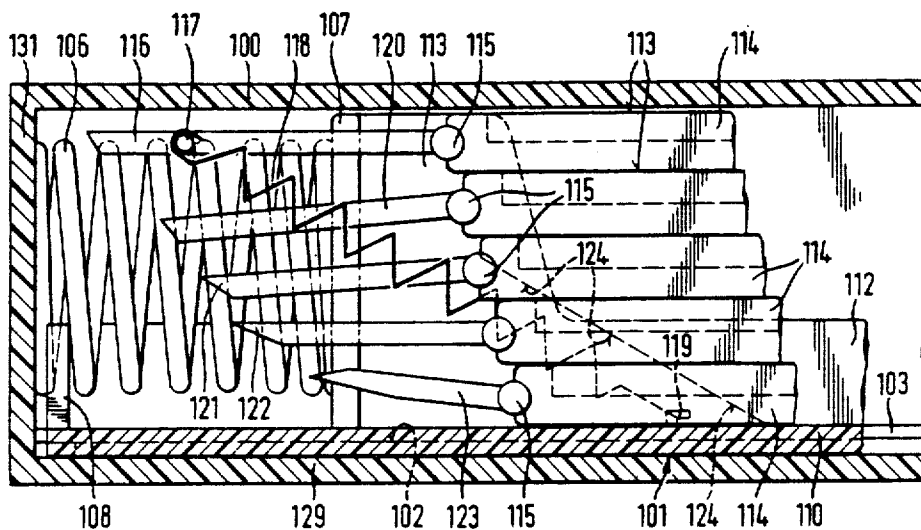
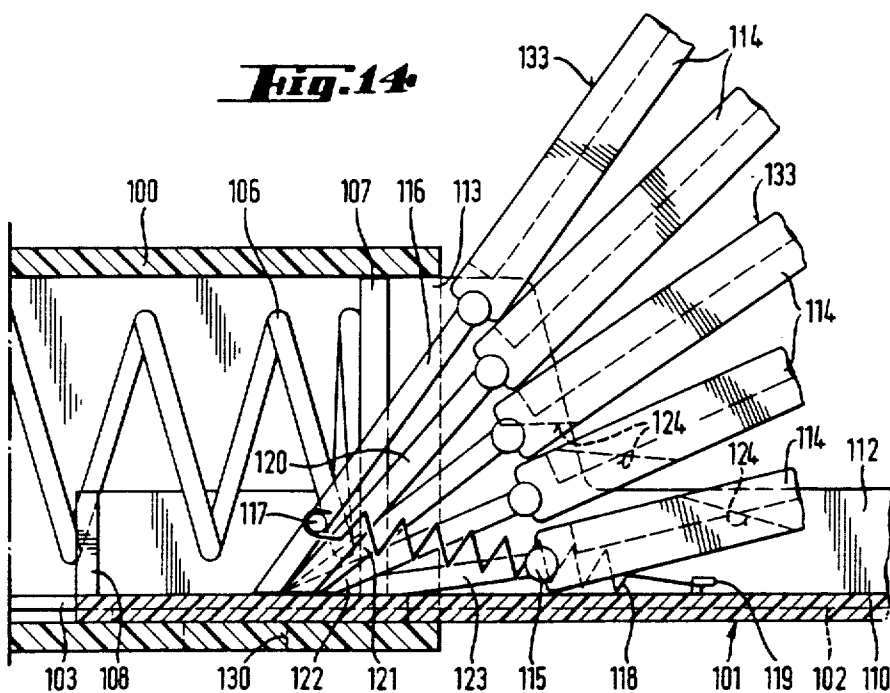

Fig. 14



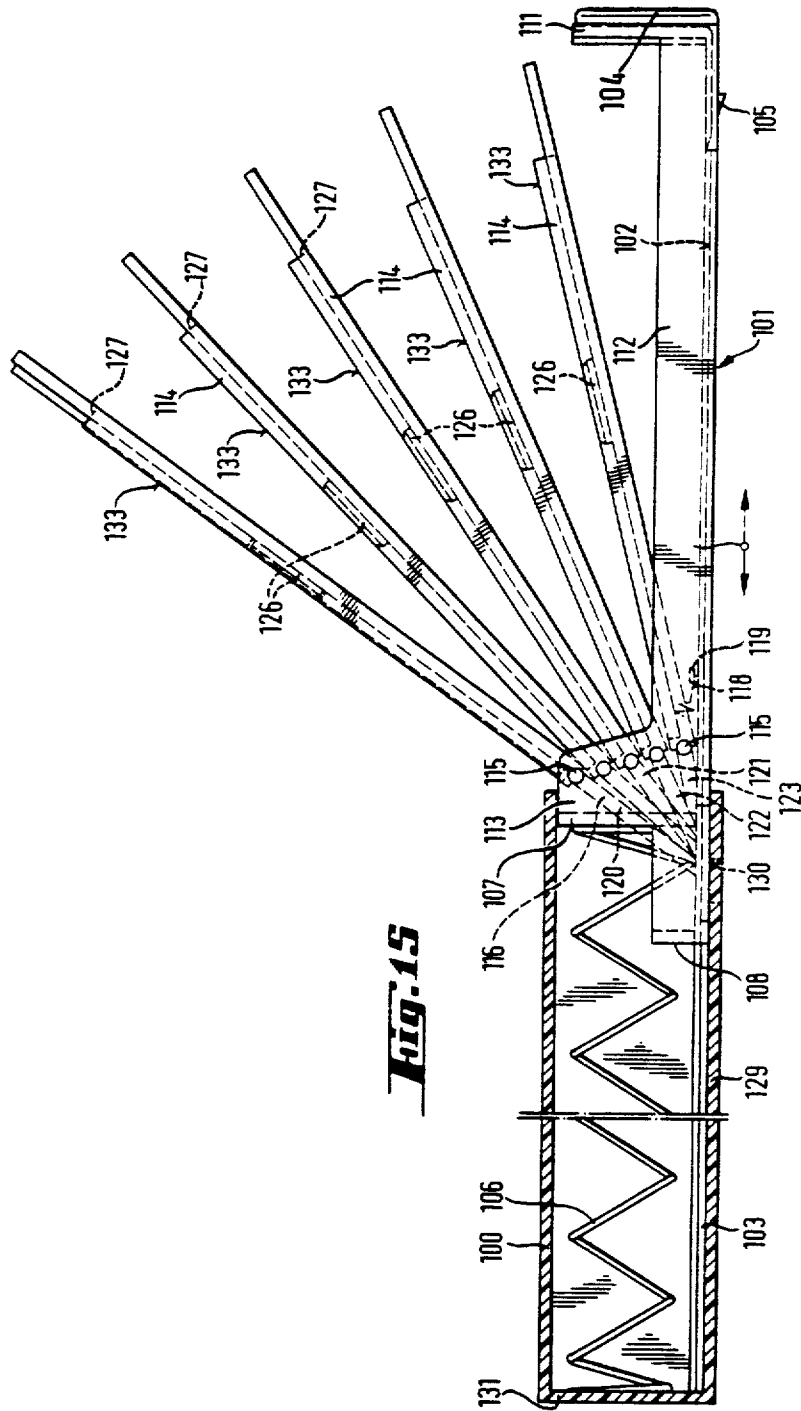

Fig. 15

STORAGE DEVICE FOR FLAT RECORDING MEDIA

Matter enclosed in heavy brackets [] appears in the original patent but forms no part of this reissue specification; matter printed in italics indicates the additions made by reissue.

BACKGROUND OF THE INVENTION

The invention relates to a storage device for recording media that have a flat form, such as magnetic tape cassettes and compact discs.

A typical device for storing such recording media is shown in U.S. Pat. No. 3,836,222. The '222 device comprises a grid-like framework relative to which slider members can be moved. Each slider member consists of a block that is guided on the framework and is screwed to a plate. On the plate in the area inside the framework is mounted a part of a locking mechanism, in front of which a box-like component, having a front wall, is fastened on the plate. On this box-like component there is hinged a pocket having an extension piece which projects into a free space provided in the framework and, when the slider member is ejected, runs up a cross-piece of the framework and as a result pivots the pocket.

One problem with the '222 device is that it requires a great deal of space in relation to the size of the recording media to be stored and, because of its complicated construction, can be manufactured only at considerable expense.

A problem with other existing devices, such as that described in German Patent Document No. PS 22 48 408, is that such devices require a certain amount of dexterity when being used. This is a significant disadvantage when the device is to be used by the driver of a motor vehicle.

SUMMARY OF THE INVENTION

The present invention solves these problems and provides other benefits. The present invention is suitable for use by a driver while driving a motor vehicle without distracting the driver's attention. At the same time, the device of the present invention requires a minimum amount of space and can be manufactured economically from a small number of components.

Broadly, the container of this invention may be defined as follows:

- A storage device for flat recording media comprising:
- (a) a housing having a bottom wall, a top wall, two elongate side walls, a rear wall, and an open front side;
 - (b) a slider member for receiving at least one recording medium, the slider member being movably mounted in the housing and having a base portion and a front wall;
 - (c) means for biasing the slider member to an open position out of the housing;
 - (d) means for locking the slider member to a closed position within the housing against the bias of the biasing means; and
 - (e) lifting means for supporting and engaging underneath the recording medium, said lifting means when the device is in the open position raising the recording medium to a lifted position away from the base portion of the slider member and above the front wall of the slider member so that the

recording medium is accessible for removal and insertion.

BRIEF DESCRIPTION OF THE DRAWINGS

To facilitate further discussion of the invention, the following drawings are provided, in which:

FIG. 1 shows a plan view, partly broken-away, of a first embodiment, intended for accommodating three magnetic tape cassettes;

FIG. 2 is a view taken along line 2—2 of FIG. 1;

FIG. 3 is a plan view of the lifting element of this embodiment;

FIG. 4 is a perspective view of a second embodiment;

FIGS. 5 to 7 are sectional views of variants of the lifting element actuation means;

FIG. 8 shows a sectional view of a further embodiment;

FIG. 9 is a view of a section parallel to the front wall of the device according to FIG. 8;

FIG. 10 shows a further embodiment, shown in an almost opened state (FIG. 10a) and in a completely opened state (FIG. 10b);

FIG. 11 shows a cut-away plan view of a device of this invention for the storage of compact discs;

FIG. 12 shows a plan view of the associated slider member;

FIG. 13 shows a sectional view of part of the arrangement of receiving platters in the storage position;

FIG. 14 shows, analogously to FIG. 13, the removal position; and

FIG. 15 shows a side sectional view of the device when open.

DETAILED DESCRIPTION OF THE INVENTION

The device according to FIGS. 1 to 3 comprises an outer housing 10 having a substantially slab-like basic form. The housing has a top wall 12, a base wall 14, a rear wall 16, and side walls 18 and 20. The side of the housing opposite the rear wall forms an open front face. Rails 22 extend along the base wall, parallel to the side walls, from the rear wall 16 to the open face of the housing. The rails 22 define a guide path for the sliding movement of a slider member 24, which comprises a rear plate 26, a base plate 28, and a front plate 30. Two parallel slots 32 extend from the rear plate 26 to the front plate 30 and divide the base plate into three separate platter elements.

The inner edges of the outer platter elements are stepped, as shown at 34, and the rails 22 engage over the steps and thus retain the slider member. A helical pressure spring 36 clamped between the rear wall 16 of the housing and the rear plate 26 of the slider member biases the slider member in the discharge direction, that is, the position shown in FIGS. 1 and 2. Stops are formed integrally with the base plate 28 of the slider member at the housing end, which stops slide in slots 38 in the base wall 14 of the housing and limit the outward travel.

In its storage position, that is, when it is inside the housing, the slider member is held against the bias of the spring 36 by means of locking means. For this purpose, a detent 40 on the underside of a key 42 is formed integrally with the base plate of the slider member. The key 42 is defined by a slot 44, which extends through the front plate 30 into the [relevant] adjacent platter element of the base. The portion 46 acts as a leaf spring that is connected with the rest of the base plate 28 by connection portion 48. This leaf spring also carries the

actuating button 50, which lies approximately in the plane of the front plate 30. By means of this button the user can lift the detent 40 out of a complementary recess 41 in the base wall of the housing, whereupon the slider member is pushed out by the pressure spring 36.

The actuating button 50, together with the front plate 30 of the slider member, substantially close the open face of the housing when the slider member is pushed in and locked.

The rear plate 26 of the slider member does not extend across the whole width of the housing and a free space is left on each side. Before the slider member is mounted in the housing, a frame piece 52 is attached to it. Its construction can be seen in FIG. 3. The frame piece 52 comprises a cassette lifting element 54 having upwardly [project] projecting lateral rims 56, the outer faces of which are at a distance from one another that is slightly smaller than the internal width of the housing between its side walls 18 and 20. From the ends of these rims inside the housing there extend inwardly toward one another hook portions 58 which are at a predetermined distance from the transverse end edge 60 of the lifting element. The gap so defined allows the frame piece 52 to be placed over the ends of the rear plate 26 of the slider member in such a manner that the lifting element can be moved to the removal position in which the lifting element 54 is pivoted upwards and outwards as in FIG. 2. In that position the rims 56 rest against the front edge of the top wall 12 of the housing. In the storage position, the lifting element 54 is substantially parallel to the base plate 28 of the slider member.

Resilient elements bias the lifting element 54 towards the pivoted-out position. Two metallic leaf springs 62 are positioned in complementary recesses 64 in the base plate 28 of the slider member and press against the underside of the lifting element 54. Lifting element 54 has projecting ribs 66 to prevent the leaf springs 62 from becoming displaced.

Leaf springs 62 typically are made from metal. It is, of course, also possible for the leaf springs 62 to be made of plastic material and integrally molded with the other components of the device. However, because the springs are permanently deflected when the device is closed it would be necessary to use a plastic material having no tendency for cold flow. That would cost more than the use of metal springs. The foregoing is true for the ejection [springs] spring 36.

On the upper side of the lifting element there are [constructed] provided upwardly projecting stops 70, against which the cassettes, such as three cassettes 76, can be supported. In order that the tape winding hubs of the cassettes 76 are secured against turning when in the storage position, the base plate 28 of the slider member has upwardly projecting retaining lugs 72. The lugs extend through holes 74 aligned with them in the lifting element 54 and into the winding hubs when the lifting element is depressed. When the slider member is in the outward position, the cassettes are lifted with their outer ends above the level of the free edge of the front plate 30. At the same time the winding hubs come free of the retaining lugs so that the cassettes can be removed from the front.

Little dexterity is required to replace the cassettes, as they can simply be placed onto the lifting element. Then the front plate 30 of the slider member is pushed into the outer housing. This causes the rims 56 to be pressed downwards by a wedge action against the front edge of the top wall 12 of the housing.

The device according to FIGS. 1-3 has been described very thoroughly, with regard to certain details, such as guides, stops, and ejection springs. Therefore, only the particular characteristic details of the other embodiments are described.

In the device of FIG. 4, unlike that of FIGS. 1 to 3, the slider member is [constructed] designed for the accommodation of two magnetic tape cassettes, for example, standardized video cassettes. The lifting element 80 is provided with a separating bar 81. The locking arrangement is located approximately in the center of the front plate of the slider member. In addition, the slider member is guided by means of its side plates 82 on the side walls of the housing rather than the rail arrangement on the base of the housing of the embodiment according to FIGS. 1-3.

FIGS. 5 to 7 illustrate three ways of actuating the lifting element 80 to a position in which the cassettes can be easily inserted and removed. In FIG. 5, the lifting element is connected to the slider member 84 by means of a pivot joint 83 and a leaf spring 79. Leaf spring 79 is fastened at one end to the base of the slider member and presses with its other, free end against the lifting element, thereby pressing the free end of the lifting element upwardly. The cassettes rest against a stop 88.

In FIG. 6, a free edge 85 of an internal wall 86 of lifting element 80 contacts an inwardly projecting bar 87 on the housing. As a result, the lifting element is pivoted about its pivot bearing 83.

In FIG. 7, a biasing spring is provided for the lifting element in the form of a torsion coil spring 89 having two leg sections or wire ends. One leg is supported on the base of the slider member and the other leg is supported against the bottom of the lifting element 80. The lifting angle is limited by stop pins 90, which extend from the sides of the lifting element into openings 91 in the side plates 82 of the slider member. Stop pins 90 come to rest against the upper end edge of those openings.

FIGS. 8 and 9 show a variant of FIG. 6. In a double housing 200, a double slider member 202 is guided in grooves 201, which are located in the horizontal plane of symmetry of the housing. Extending from a central plate 204 of the slider member are pairs of lateral bearing blocks 203 and 203'. In the upper bearing blocks 203, a lifting element 205, analogous to the lifting element 80 in FIGS. 4 to 7, is mounted such that it can be pivoted through a limited angle. A suspension element 206 is pivotably mounted in the lower bearing blocks 203'. Suspension element 206 comprises a platter 208 designed to accommodate one or more cassettes 207 and a suspension plate 209. Suspension plate 209 extends upwardly at a right angle from platter 208 to a pivotal engagement with bearing block 203'.

The lifting element 205 is lowered by the force of gravity when the slider is pushed in. The suspension element 206 is lifted by wedge action when platter 208 hits the front edge 210 of the housing. At the same time, edge 210 limits the downward pivoting movement of suspension element 206. Retaining lugs 211 are formed, in mirror-symmetrical arrangement, integrally with the central plate 204 of the slider member. When the cassette 207 on lifting element 205 is lowered, the retaining lugs 211 engage through openings 212 in the lifting element. The lower retaining lugs are free to pass from above through the tape winding hubs in cassette 207 on the suspension element 206. A double front plate 213 is

provided at the outer end of the central plate 204 of the slider member. Stops 214 prevent the cassettes from slipping.

The embodiments described are devices for storing magnetic tape cassettes. The following two embodiments are used for accommodating records or video discs, and especially for storing standardized, so-called "compact discs." Because these discs are very thin in relation to their diameter, the space in the interior of the housing is best utilized when the discs are closely packed together when in the housing. The discs are presented for convenient removal when the discs are out of the housing.

The embodiment shown in FIGS. 10a and 10b comprises a slider member 301, which can be pushed out of and into a housing 300. On each side of front plate 309 of the slider is hinged a pair of guide bars 302. Guide bars 302 are pivotable about axes 303 and extend parallel to the front plate 309 of the slider member when the slider member is withdrawn from the housing member. The relationship of the distance between the pairs of axes 303 to the length of the guide bars 302 is such that when the slider member is withdrawn from the housing both guide bars are free to pivot upwardly. However, in the storage position, the guide bars are pivoted inwardly so that an uppermost disc-holder 304 will still fit underneath top wall 305 of the housing. The free ends of the guide bars are hinged to uppermost disc-holder 304 at the same axial spacing the other ends of the guide bars are spaced on the slider member. The other disc-holders 306, 307, and 308 are hinged to guide bars 302 through axes. Although the spacing between the axes is constant, the distance between the pivot axes and the front plate 309 of the slider member increases from right to left in FIG. 10a.

In the open position the lowermost disc-holder 308 extends into the housing 300. Actuator extensions 312 of disc-holder 308 project laterally from the disc-holder, close to the open front of the housing. Extensions 312 engage behind guide ribs 311, which project inwardly from side walls 310 of the housing. As soon as the actuator extensions 312 contact the guide ribs 311 when the slide is ejected, the actuator extensions 312 slide upwardly along the guide ribs 311.

The parallelogram arrangement is formed by the guide bars and the disc-holders hinged thereon in the unfolded position according to FIG. 10b. In the unfolded position, the individual disc-holders are sufficiently spaced apart for the compact discs 313 lying on them to be accessible from above and pushed forward with the fingers. If desired, the disc-holders can be provided with a cut-out portion at the front for access to the discs. In addition, the holders are stepped backwards to further facilitate access to the discs.

In FIGS. 11-15 a slider member 101 is slidably movable in the housing 100. For this purpose, the slider member comprises two base plates 109 and 110, which are connected to one another at the front of the slider member by a front plate 111 and at the rear by a rear plate 108. A step 102 projects from both base plates into the empty space 128 between these plates. Two guide rails 103 project inwardly from the housing base 129 and engage over these steps. The base plates 109 and 110 are reinforced by upright side edges 112. These edges, near the inner end of the slider member, become cheeks 113, which are joined to lugs 107. The lugs extend at right-angles to the cheeks. The height of cheeks 113 and the lugs 107 is substantially the height of the

interior of the housing, as shown in FIG. 15. Helical pressure springs 106 are supported at one end against rear wall 131 of the housing and at the other end against the lugs 107. Springs 106 force the slider member out of the housing. In its insertion position, the slider member 101 is secured by a catch 105, which locks into a recess 130 in the housing base 129. The catch 105 is integrally formed with a spring button 104 and can be released by raising button 104 with the finger. Because the slider member is made of resiliently deformable plastic material, the spring button 104 can be readily separated from the material of the base plate 109 by means of the slits 104a shown in FIG. 12. The extent to which the slider member can be ejected is limited by stops which cooperate with counter stops in the housing (not shown).

Bearing pins 11 of receiving platters 114 for respective compact discs 125 are accommodated in bearing apertures 132 in the cheeks 113. A total of five receiving platters are arranged one above the other. The individual receiving platters 114 differ from one another in the shape and position of their lever arms 116, 120, 121, 122, and 123. The lever arm 116 of the uppermost receiving platter 114 extends substantially over the width of the slider member between the springs 106. At the end of lever arm 116 are two pegs or hooks 117 which project laterally. Onto each hook 117 is hooked a tension spring 118. The other ends of the tension springs 118 are anchored in lugs 119, which project upwardly from the base plates 109 and 110 of the slider member. Accordingly, if the slider member 101 is unlocked and ejected from the housing 100 by the springs 106, a torque produced by the biasing of the springs 118 acts on the lever arm 116 and the uppermost receiving platter 114 is swung into the position shown in FIG. 15.

During this swinging movement, the other receiving platters are spread out as a result of the lever arm 116 of the uppermost platter acting on the lever arms 120, 121, and 122, arranged next to one another in a staggered configuration. Lever arms 120, 121, and 122 are activated by lever arm 116. Because the lever arms are of different lengths, their angle of spread is correspondingly smaller than that of the uppermost platter 114. For the lowest receiving platter, the lever ratios for operation by the lever arm 116 are unfavorable. Therefore, the lever arm 123 is activated, not by the lever arm 116, but by the lever arm 122 arranged above it (FIG. 14). The three lowest receiving platters have cut-out portion 124 so that there is room for the tension springs 118.

The records are held securely in position by means of central hub projections 126. The records can be raised by gripping them in the area of the front cut-out portions 127 of the receiving platters. A supporting rim 133 of the receiving platters defines their distance from one another in the storage position.

Variations and modifications will be apparent to one skilled in the art, and the claims are intended to cover all variations and modifications that fall within the true spirit and scope of the invention.

I claim:

1. A storage device for flat recording media comprising:
 - (a) a housing having a bottom wall, a top wall, two elongate side walls, a rear wall, and an open front side;
 - (b) a slider member for receiving at least one recording medium, the slider member being movably mounted in the housing and having a base portion and a front wall;

- (c) means for biasing the slider member to an open position out of the housing;
- (d) means for locking the slider member to a closed position within the housing against the bias of the biasing means; and
- (e) lifting means for supporting and engaging underneath the recording medium, said lifting means when the device is in the open position raising the recording medium to a lifted position away from the base portion of the slider member and above the front wall of the slider member so that the recording medium is accessible for removal and insertion.]

[2. A device according to claim 1 wherein the lifting means supports a plurality of recording media.]

[3. A device according to claim 1 wherein the lifting means comprises at least one spring to bias the recording medium towards the lifted position.]

[4. A device according to claim 3 wherein the spring is a leaf spring.]

[5. A device according to claim 3 wherein the spring is a wire spring.]

[6. A device according to claim 5 wherein the spring is a torsion coil spring having two wire ends, one wire end being supported by the base portion of the slider member and the other wire end being supported by the recording medium.]

[7. A device according to claim 3 wherein the lifting means further comprises a platter-like component located between the spring of the lifting means and the recording medium.]

[8. A device according to claim 7 wherein stop means is provided on the platter-like component for supporting the recording medium lying on the platter-like component in the lifted position.]

[9. A device according to claim 1 wherein the lifting means comprises at least one platter element that is hingedly attached the slider member by a parallelogram means.]

[10. A device according to claim 1 wherein the housing can accommodate a plurality of compact discs packed closely together in a stack one above the other, each of the compact discs having its own lifting means.]

[11. A device according to claim 10 wherein each disc is supported by a platter-like holder.]

[12. A device according to claim 1 wherein the biasing means comprises a pressure spring element attached at one end to the slider member at a point remote from the front wall of the slider member and at the other end to the rear wall of the housing.]

[13. A device according to claim 12 wherein the pressure spring elements are supported against buckling.]

[14. A device according to claim 12 wherein the pressure spring elements also actuate the lifting means when the device is in the open position.]

[15. A device according to claim 1 wherein the housing has a substantially rectangular shape and a plurality of recording media can be accommodated therein, the principal planes of the recording media lying parallel to the largest surfaces of the housing when the device is in the closed position.]

[16. A device according to claim 11 wherein each platter-like holder is pivotably connected to the slider member and is pivotable about an axis extending parallel to the front wall of the slider member.]

[17. A device according to claim 1 wherein the lifting means engages the recording medium at a point that lies between the edge of the recording medium and the center of gravity of the recording medium.]

[18. A device according to claim 17 wherein the lifting means extends from the end of the slider member inside the housing to a point just behind the front wall of the slider member.]

19. A container for one or more magnetic tape cassettes comprising:

a cassette housing,

a drawer associated with said housing and movable between a first inserted position in said housing and a second exposed position,

said drawer having a front plate,

an ejector spring operatively connected to said drawer for moving said drawer from said first position to said second position,

a locking means connected to said housing for locking said drawer in said first position,

a cassette carrier adapted to support a cassette and attached to said drawer, and

a spring means associated with said cassette carrier and said drawer for biasing said cassette carrier relative to said drawer such that said cassette carrier lifts a cassette supported thereon above said front plate when said drawer is in said second position permitting the manual removal of the cassette from said drawer over said front plate.

20. The container of claim 19 including, said cassette carrier and said drawer having interengaging stop means.

21. The container of claim 20 including, said housing including a housing wall, and said stop means comprising upstanding side walls adapted to engage said housing wall.

22. The container of claim 21 including, said upstanding side walls and said cassette carrier being integrally injection-molded.

23. The container of claim 19 including, said drawer having bottom wall portions provided with a positioning means for positioning said spring means.

24. The container of claim 19 including, said drawer having bottom wall portions carrying posts adapted to engage into tape reel hubs of cassettes supported by said cassette carrier, and said cassette carrier having cassette carrier perforations in alignment with said posts such that with said drawer in said first position, said posts protrude through said perforations.

25. The container of claim 24 including, said posts having post free ends, and said cassette carrier with said drawer in said second position, being substantially flush with said post free ends.

26. The container of claim 19 including, said spring means including a leaf spring means.

27. The container of claim 19 including, said drawer having a rear plate opposite said front plate, and said cassette carrier having projections adapted to engage said rear plate to pivotally attach said cassette carrier to said drawer.

28. The container of claim 19 including, said spring means comprising a coil spring.

29. The container of claim 19 including, said housing including housing slots, and

said drawer having projecting stop members engaging into said housing slots so as to define said second position of said drawer.

30. The container of claim 19 including, said locking means comprising a first locking means formed integrally with said housing and a second locking means formed integrally with said drawer.

31. The container of claim 1 including, said cassette carrier being pivotally attached to said drawer.

32. The container of claim 19 including, said cassette carrier defining a plurality of apertures therethrough.

33. A container for one or more magnetic tape cassettes comprising:
 a housing,
 a drawer associated with said housing and movable between a first inserted position in said housing and a second exposed position,
 said drawer having a front plate,
 an ejector spring operatively connected to said drawer for moving said drawer from said first position to said second position,
 a locking means connected to said housing for locking said drawer in said first position,
 a cassette carrier having a free end and another end opposite to said free end and attached to said drawer, such that said free end is movable relative to said drawer,
 a spring means associated with said cassette carrier and said drawer for biasing said cassette carrier relative to said drawer such that said cassette carrier lifts a cassette supported thereon above said front plate when said drawer is in said second position, and
 said cassette carrier being positioned to contact said spring means and positioned between the forward portion of a cassette being inserted into said drawer and said spring means so that the forward portion of the cassette inserted into said drawer impacts said cassette carrier.

34. The container of claim 33 including, said drawer having bottom wall portions, and said cassette carrier extending over substantially the entire depth of said bottom wall portions.

35. The container of claim 34 including, said drawer bottom wall portions being provided with positioning means adapted to engage at least a portion of said spring means.

36. The container of claim 33 including, said front plate having an upper edge, and said cassette carrier having a front edge adjacent said drawer front plate and spaced therefrom and, with said drawer in said second position, substantially flush with said upper edge.

37. The container of claim 36 including, said spring means contacting said cassette carrier adjacent said front edge.

38. The container of claim 33 including, said cassette carrier defining a plurality of apertures therethrough.

39. A container for one or more magnetic tape cassettes comprising:
 a housing,
 a drawer associated with said housing and movable between a first inserted position in said housing and a second exposed position,
 said drawer having a front plate,

an ejector spring operatively connected to said drawer for moving said drawer from said first position to said second position,
 a locking means connected to said housing for locking said drawer in said first position, and
 an elongated leaf spring extending longitudinally relative to said drawer, attached to said drawer and having an end generally adjacent the front of said drawer and adapted to exert a bias on the front end of a cassette supported by said drawer to lift the cassette forward end so that the forward end is positioned above said front plate, when said drawer is in said second position, permitting the removal of the cassette over said front plate and from said drawer.

40. The container of claim 39 including, said leaf spring extending over substantially the entire depth of said drawer.

41. The container of claim 39 including, said drawer having an inner end, and said leaf spring being attached to said drawer adjacent said inner end.

42. The container of claim 39 including, said leaf spring having a substantially rectangular contour.

43. The container of claim 39 including, said drawer including a leaf spring locating means.

44. The container of claim 43 including, said drawer including drawer bottom wall portions, and said leaf spring locating means being disposed on said drawer on said drawer bottom wall portions.

45. The container of claim 39 including, a cassette carrier pivotably connected to said drawer and disposed substantially coextensive with and above said leaf spring.

46. The container of claim 39 including, a second leaf spring extending longitudinally relative to and attached to said drawer.

47. The container of claim 45 including, said cassette carrier defining a plurality of apertures therethrough.

48. A storage device for flat recording media comprising:
 a housing having a bottom wall, a top wall, two side walls, a rear wall, and an open front side,
 a slider member for receiving at least one recording medium, said slider member being movably mounted in said housing and having a base portion and a front wall,
 a biasing means for biasing said slider member to an open position out of said housing,
 a locking means for locking said slider member to a closed position within said housing against the bias of said biasing means,
 a lifting means for supporting and engaging underneath the recording medium, said lifting means when the device is in the open position raising the recording medium to a lifted position away from said base portion of said slider member so that the recording medium is accessible for removal and insertion, and
 said lifting means comprising at least one spring to bias the recording medium towards the lifted position, and a platter member located between said spring and the recording medium.

49. The device according to claim 48 wherein said spring is a leaf spring.

50. The device according to claim 48 wherein said spring is a wire spring.

51. The device according to claim 50 wherein said wire spring is a torsion coil spring having two wire ends, one wire

end being supported by said base portion of said slider member and the other wire end being supported by said platter member.

52. The device according to claim 48 wherein a stop means is provided on said platter member for supporting the recording medium lying on said platter member in the lifted position.

53. The device according to claim 48 wherein said lifting means is adapted to support a plurality of recording media.

54. The device according to claim 48 wherein said biasing means comprises a pressure spring element engaging at one end thereof said slider member at a location remote from said front wall of said slider member and at the other end engaging said rear wall of said housing.

55. The device according to claim 54 wherein said pressure spring element actuates said lifting means when the device is in the open position.

56. The device according to claim 48 wherein said housing has a substantially rectangular shape and is configured so that a plurality of recording media can be accommodated therein, the principal planes of the recording media lying parallel to the largest surfaces of said housing when the device is in the closed position.

57. The device according to claim 48 wherein said lifting means lifts the front end of the recording medium above said front wall of said slider member.

58. A storage device for flat recording media comprising: a housing having a bottom wall, a top wall, two side walls, a rear wall, and an open front side,

a slider member for receiving at least one recording medium, said slider member being movably mounted in said housing and having a base portion and a front wall,

a biasing means for biasing said slider member to an open position out of said housing,

a locking means for locking said slider member to a closed position within said housing against the bias of said biasing means,

a lifting means for supporting and engaging underneath the recording medium, said lifting means when the device is in the open position raising the recording medium to a lifted position away from said base portion of said slider member so that the recording medium is accessible for removal and insertion, and said lifting means comprising at least one platter element and an attaching means for hingedly attaching said at least one platter element to said slider member.

59. The device according to claim 58 wherein said lifting means engages the recording medium at a location that lies between the edge of the recording medium and the center of gravity of the recording medium, and extends from the end of said slider member inside said housing to a location just behind said front wall of said slider member.

60. The device according to claim 58 wherein said lifting means is adapted to support a plurality of recording media.

61. The device according to claim 58 wherein said lifting means comprises at least one spring for biasing the recording medium towards said lifted position.

62. The device according to claim 61 wherein said spring is a leaf spring.

63. The device according to claim 61 wherein said spring is a wire spring.

64. The device according to claim 63 wherein said wire spring is a torsion coil spring having two wire ends, one wire end being supported by the base portion of said slider member and the other wire end being supported by the recording medium.

65. The device according to claim 58 wherein said housing is configured to accommodate a plurality of compact discs packed closely together in a stack one above the other.

66. The device according to claim 58 wherein said biasing means comprises a pressure spring element engaging at one end thereof said slider member at a location remote from said front wall of said slider member and at the other end engaging said rear wall of said housing.

67. The device according to claim 66 wherein said pressure spring element actuates said lifting means when the device is in the open position.

68. The device according to claim 58 wherein said housing has a substantially rectangular shape and is configured so that a plurality of recording media can be accommodated therein, the principal planes of the recording media lying parallel to the largest surfaces of the housing when the device is in the closed position.

69. The device according to claim 58 wherein said attaching means comprises a parallelogram-shaped attaching means.

70. The device according to claim 58 wherein said lifting means lifts the front end of the recording medium above said front wall of said slider member.

71. A storage device for compact discs comprising: a housing having a bottom wall, a top wall, two side walls, a rear wall, and an open front side,

a slider member for receiving at least one compact disc, said slider member being movably mounted in said housing and having a base portion and a front wall,

a biasing means for biasing said slider member to an open position out of said housing,

a locking means for locking said slider member to a closed position within said housing against the bias of said biasing means,

a lifting means for supporting and engaging underneath the compact disc, said lifting means when the device is in the open position raising the compact disc to a lifted position away from said base portion of said slider member so that the compact disc is accessible for removal and insertion,

said housing being adapted to accommodate a plurality of compact discs packed closely together in a stack one above the other, each of the compact discs having its own said lifting means,

a holder platter for supporting each of the compact discs, and

each said holder platter being pivotably connected to said slider member and pivotable about an axis extending parallel to said front wall of said slider member.

72. The device according to claim 71 wherein said lifting means lifts the front end of the compact disc above said front wall of said slider member.

73. A storage device for flat recording media comprising: a housing having a bottom wall, a top wall, two side walls, a rear wall, and an open front side,

a slider member for receiving at least one recording medium, said slider member being movably mounted in said housing and having a base portion, a pair of opposed side walls and a front wall,

a biasing means for biasing said slider member to an open position out of said housing,

said biasing means comprising a pressure spring element attached at one end to said slider member at a location remote from said front wall of said slider member and at the other end to said rear wall of said housing,

a locking means for locking said slider member to a closed position within said housing against the bias of said biasing means,

13

a lifting means for supporting and engaging underneath the recording medium, said lifting means when the device is biased into said open position by said pressure spring element raising the recording medium to a lifted position away from said base portion of said slider member so that the recording medium is accessible for removal and insertion over said front wall, and

said lifting means engaging the recording media at a location that lies between the edge of the recording medium and the center of gravity of the recording medium, and extends from the end of said slider member inside said housing to a location just behind said front wall of said slider member.

74. The device according to claim 73 wherein said lifting means lifts the front end of the recording medium above said front wall of said slider member.

75. A container for one or more magnetic tape cassettes comprising:

a cassette housing,

a drawer movable between a first position inserted in said housing and a second position extending at least partially out of said housing,

said drawer having a front plate and a rear plate opposite to said front plate,

an ejector spring means for moving said drawer from said first position to said second position,

a locking means for locking said drawer in said first position,

a cassette carrier adapted to support a cassette and movably attached to said drawer,

projections engagable with said rear plate to pivotally attach said cassette carrier to said drawer, and

a spring means for biasing said cassette carrier relative to said drawer such that said cassette carrier lifts a cassette supported thereon relative to said front plate when said drawer is in said second position permitting the manual removal of the cassette from said drawer over said front plate.

76. The container of claim 75 including, said projections being integrally injection molded with said cassette carrier.

77. The container of claim 75 including, a stop means for defining a lifted position of said cassette carrier relative to said drawer when said drawer is in said second position.

78. The container of claim 75 including,

5

10

15

20

25

30

35

40

50

55

60

65

14

said cassette carrier having a first end free to move relative to said drawer and a second end opposite to said first end and attached to said drawer.

79. A container for one or more magnetic tape cassettes having tape reel hubs comprising:

a cassette housing,

a drawer movable between a first position inserted in said housing and a second position extending at least partially out of said housing,

said drawer having a front plate,

an ejector spring means for moving said drawer from said first position to said second position,

a locking means for locking said drawer in said first position,

a cassette carrier adapted to support a cassette and movably attached to said drawer,

a spring means for biasing said cassette carrier relative to said drawer such that said cassette carrier lifts a cassette supported thereon when said drawer is in said second position permitting the manual removal of the cassette from said drawer over said front plate, and said drawer having bottom wall portions and posts carried by said bottom wall portions and adapted to engage into tape reel hubs of cassettes supported by said cassette carrier.

80. The container of claim 79 including, said cassette carrier having perforations aligned with said posts so that said posts protrude through said perforations when said drawer is in said first position.

81. The container of claim 79 including, said posts having outer ends, and said cassette carrier, when said drawer is in said second position, being substantially flush with said outer post ends.

82. The container of claim 79 including, a stop means for defining a lifted position of said cassette carrier relative to said drawer when said drawer is in said second position.

83. The container of claim 79 including, said cassette carrier having a first end free to move relative to said drawer and a second end opposite to said first end and attached to said drawer.

84. The container of claim 79 including, said spring means biasing said cassette so that the front end of the cassette supported thereon is lifted above said front plate.

* * * * *