



(19) **United States**
(12) **Patent Application Publication**
Bugler

(10) **Pub. No.: US 2015/0230741 A1**
(43) **Pub. Date: Aug. 20, 2015**

(54) **ASSESSING MEASURES OF GLYCEMIC VARIABILITY**

(71) Applicant: **Abbott Diabetes Care Inc.**, Alameda, CA (US)

(72) Inventor: **Jolyon Robert Bugler**, Combe (GB)

(73) Assignee: **Abbott Diabetes Care Inc.**, Alameda, CA (US)

(21) Appl. No.: **14/705,889**

(22) Filed: **May 6, 2015**

Related U.S. Application Data

- (63) Continuation of application No. 13/854,005, filed on Mar. 29, 2013, which is a continuation of application No. 12/257,353, filed on Oct. 23, 2008, now Pat. No. 8,409,093.
- (60) Provisional application No. 60/982,110, filed on Oct. 23, 2007.

Publication Classification

- (51) **Int. Cl.**
A61B 5/145 (2006.01)
A61B 5/00 (2006.01)
- (52) **U.S. Cl.**
CPC *A61B 5/14532* (2013.01); *A61B 5/7282* (2013.01); *A61B 5/7278* (2013.01); *A61B 5/742* (2013.01); *A61B 5/7455* (2013.01); *A61B 5/7405* (2013.01)

(57) **ABSTRACT**

Methods, devices and systems for receiving an instruction to determine a glycemic variation level, retrieving a stored metric for determining the glycemic variation level, retrieving one or more parameters associated with the retrieved metric analysis, determining the glycemic variation level based on the retrieved one or more parameters for the retrieved metric analysis, and outputting the determined glycemic variation level when it is determined that the retrieved one or more parameters associated with the retrieved metric analysis meets a predetermined condition are disclosed.

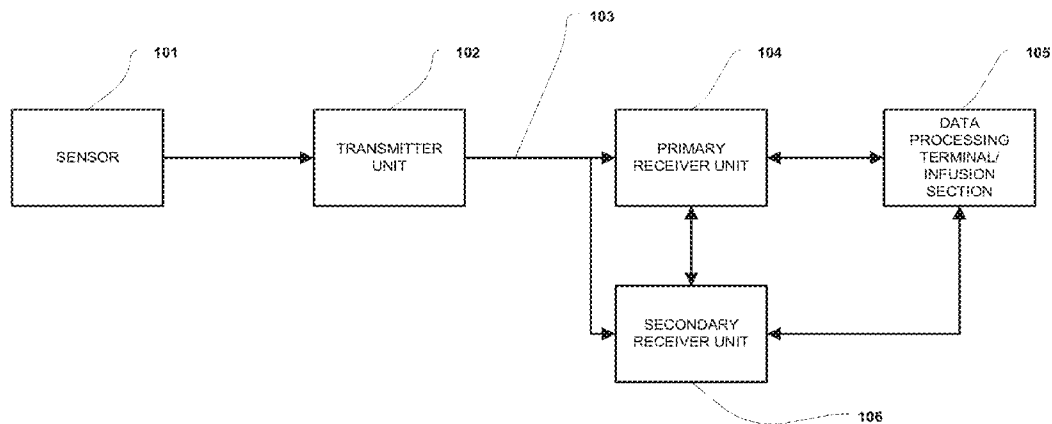

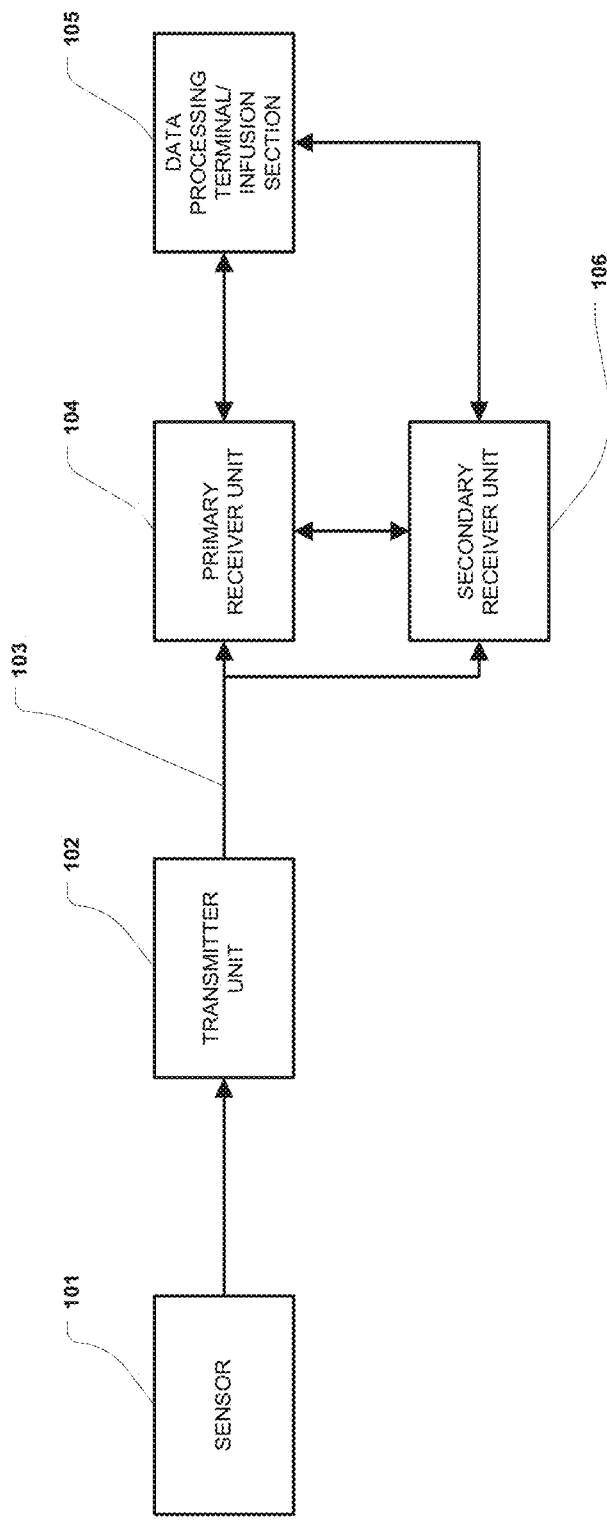

100

FIGURE 1

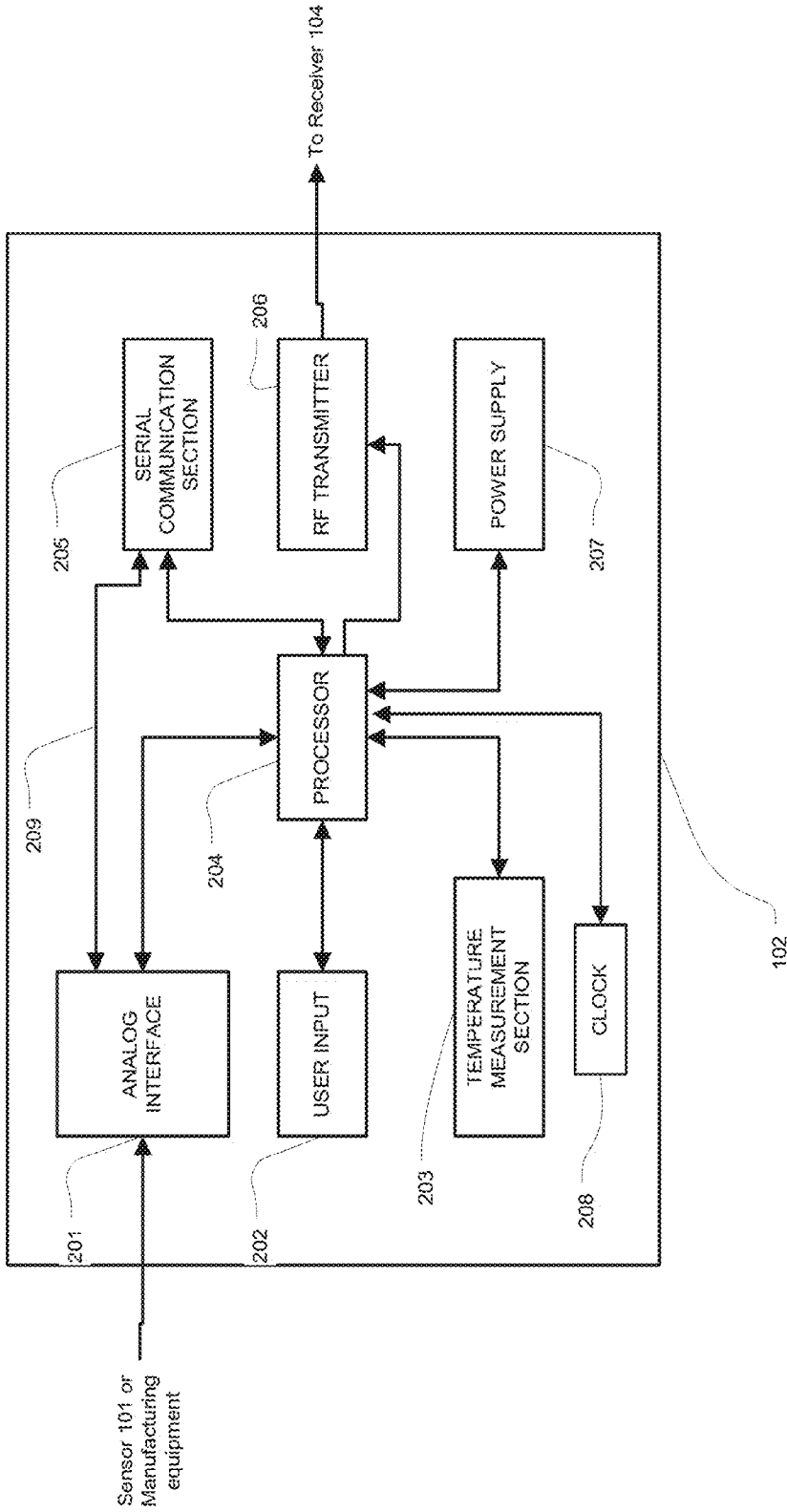

FIGURE 2

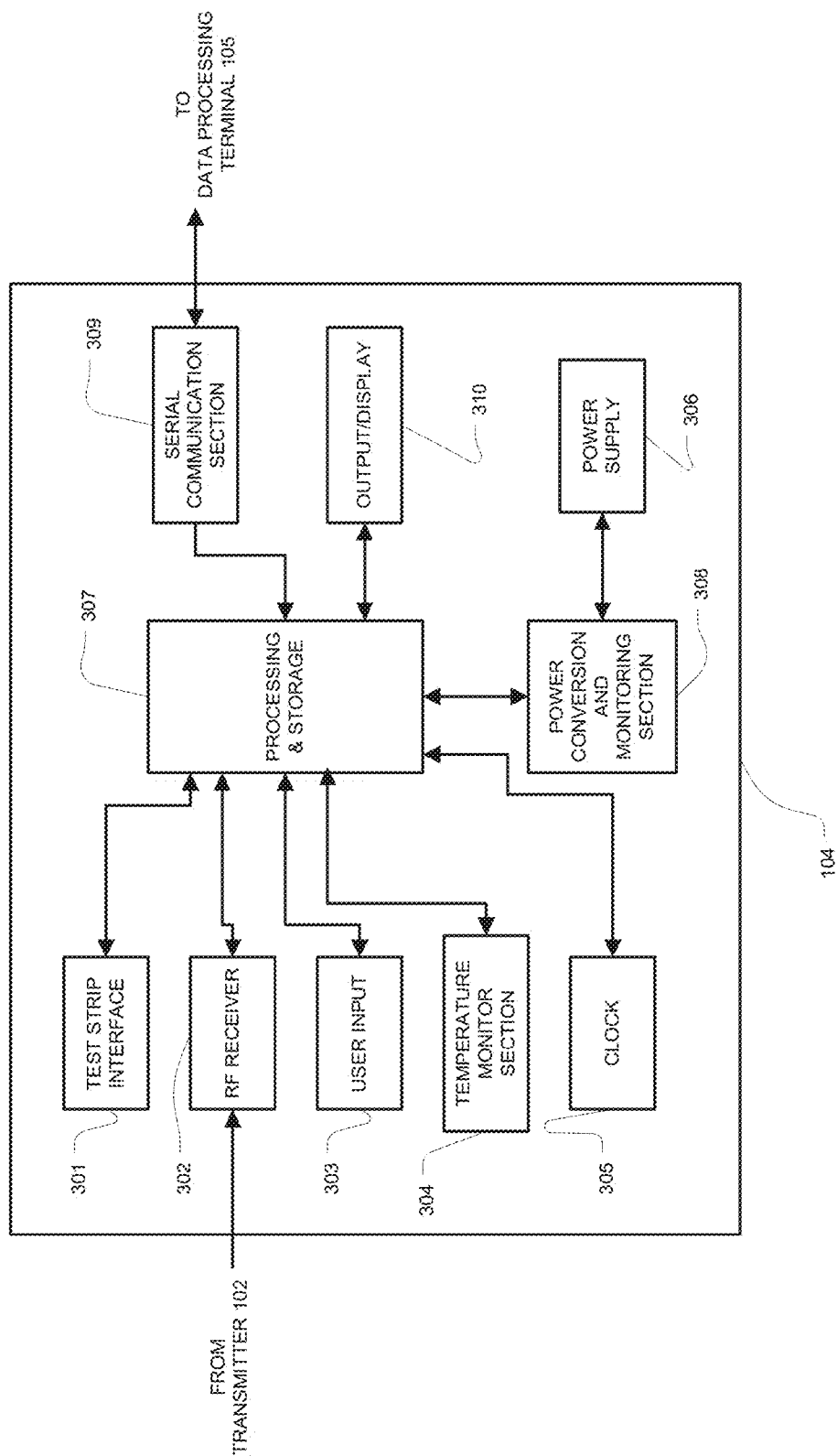

FIGURE 3

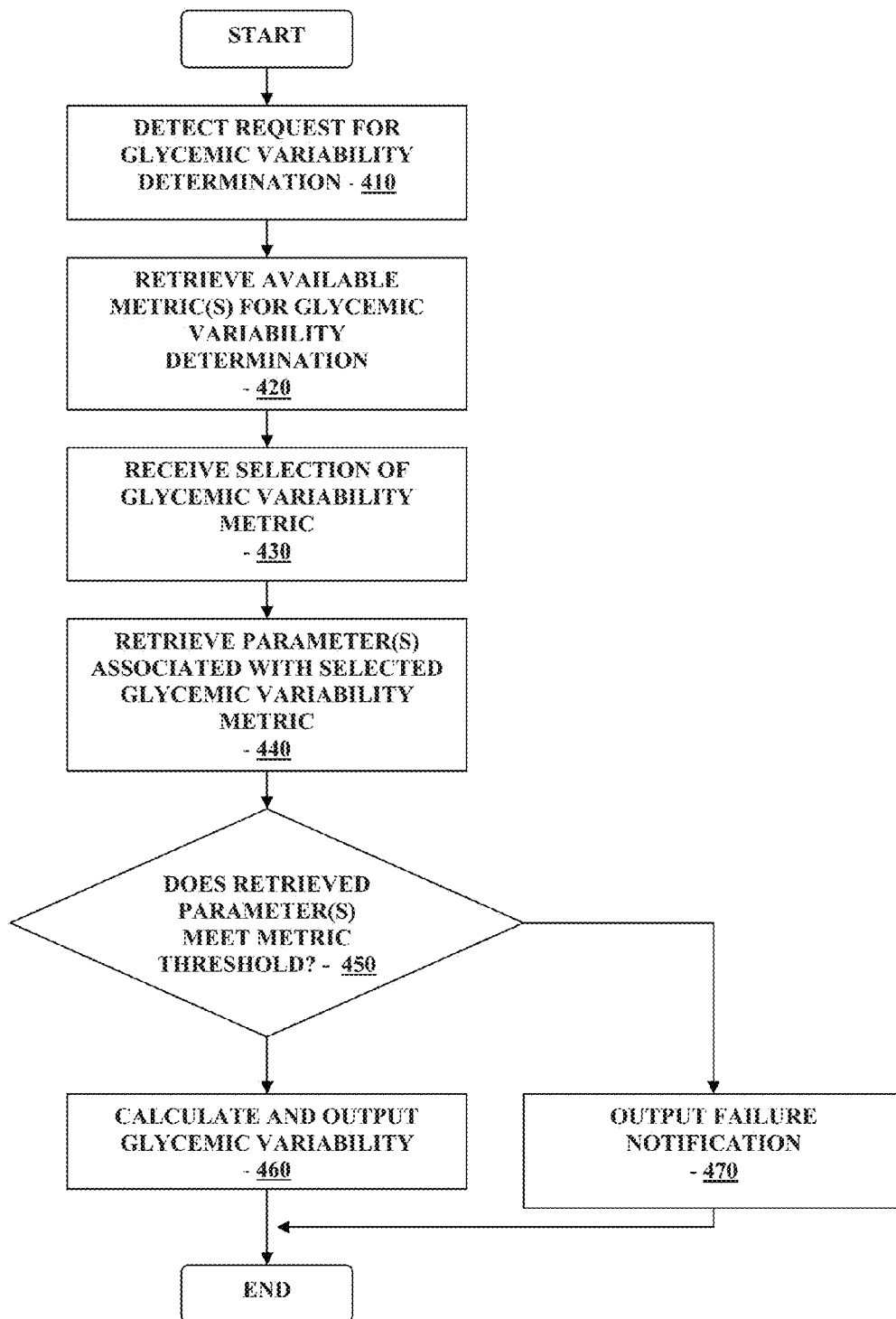

FIGURE 4

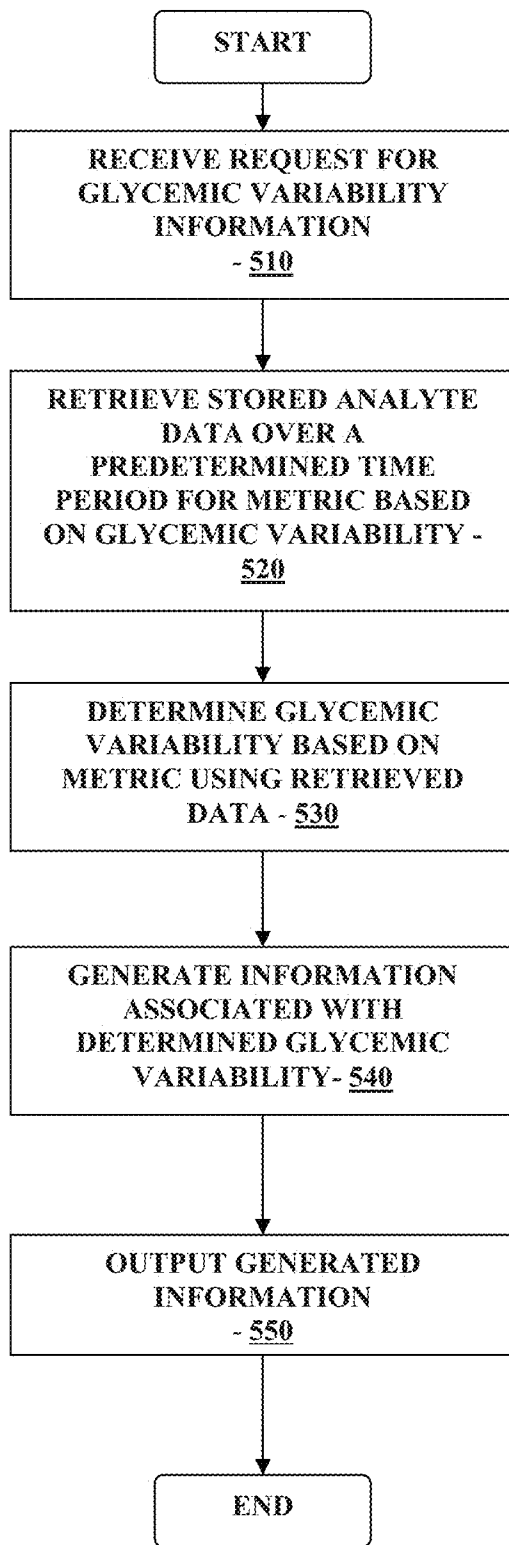

FIGURE 5

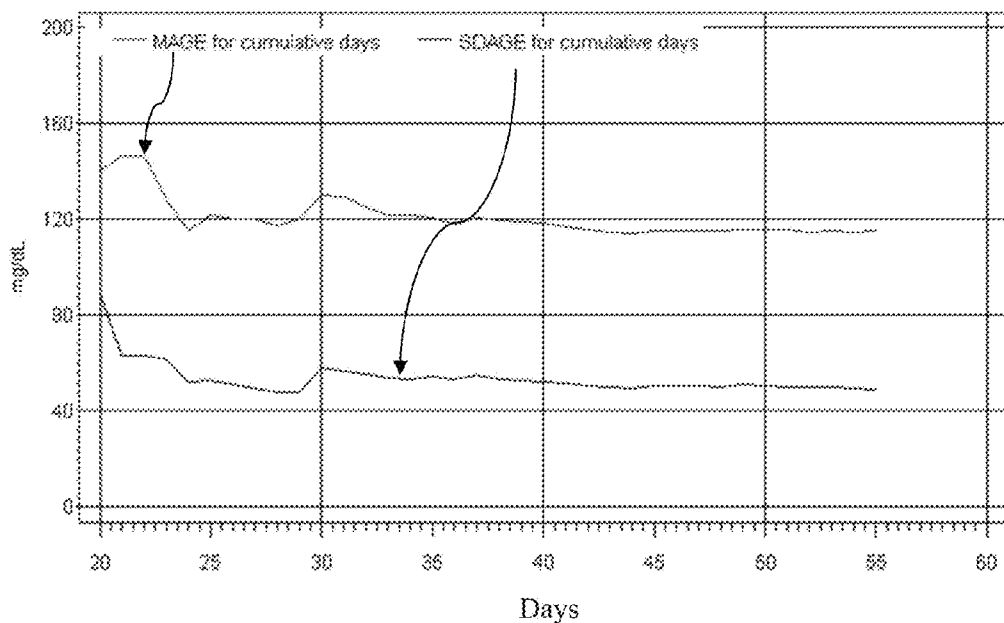

FIGURE 6

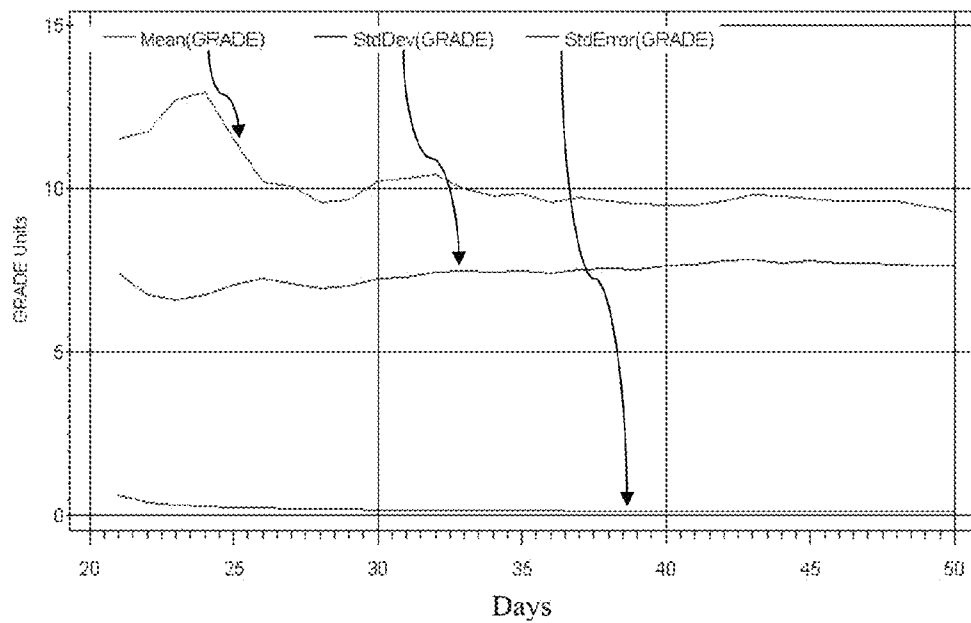

FIGURE 7

Measure		Overall Mean (SD)	Typical requirement for ±10% of Subjects's Overall Value
Glucose SD		52 mg/dL (10)	5 mg/dL
Proportion of time (Hours per day)	Hypo (<70mg/dL)	1.0 hrs (0.9)	6mins (0.1hrs)
	Hyper (>180mg/dL)	6.2 hrs (3.4)	37mins (0.62hrs)
Number of Episodes per day	Hypo (<70mg/dL)	1.2 (0.8)	0.13 episodes
	Hyper (>180mg/dL)	2.3 (0.7)	0.23 episodes
Average Maximum Excursion Value	Hypo (excursion below 70mg/dL)	14 mg/dL (3.2)	1.4 mg/dL
	Hyper (excursion above 180mg/dL)	47 mg/dL (15)	5 mg/dL
MAGE	increasing	114 mg/dL (21)	11 mg/dL
	decreasing	117 mg/dL (22)	12 mg/dL
Lablity Index		1,400 (448)	140
Kovatchev Risk Score	LBGI	1.34 (0.94)	0.13
	HBGI	5.61 (2.90)	0.56
GRADE		7.6 (2.6)	0.76

FIGURE 8

Measure		Mean	SD	MIN	MAX	90th percentile
Glucose SD		8	6.2	1	25	18
Proportion of time (Hours per day)	Hypo (<70mg/dL)	25	3.6	11	30	28
	Hyper (>180mg/dL)	20	5.8	6	29	27
Number of episodes per day	Hypo (<70mg/dL)	23	5.7	5	30	28
	Hyper (>180mg/dL)	17	7.2	2	28	26
Average Maximum Excursion Value	Hypo (excursion below 70mg/dL)	17	7	3	30	27
	Hyper (excursion above 180mg/dL)	17	6.4	4	28	26
MAGE	increasing	5	4.4	1	20	12
	decreasing	6	3.9	1	20	11
Lablity Index		15	6.6	3	27	24
Kovatchev Risk Score	LBGI	22	5.8	6	30	28
	HBGI	19	6.6	3	28	26
GRADE		12	6.8	1	25	22

FIGURE 9

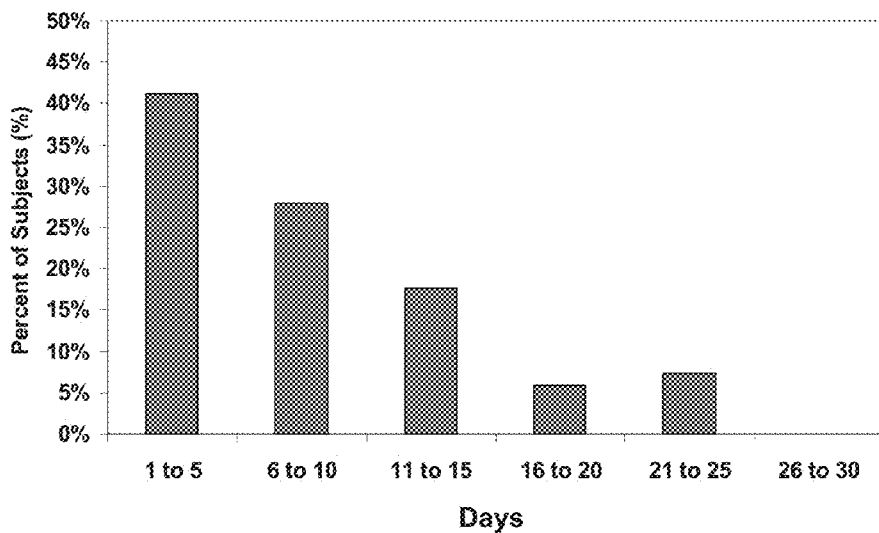

FIGURE 10

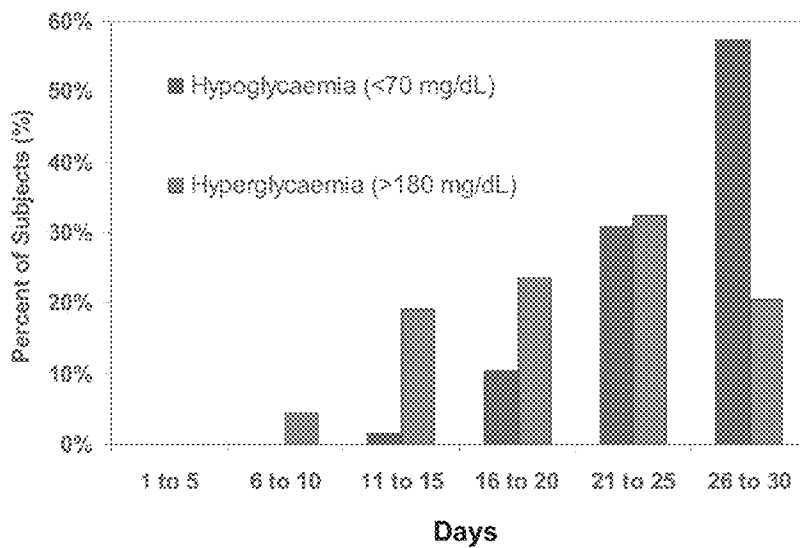

FIGURE 11

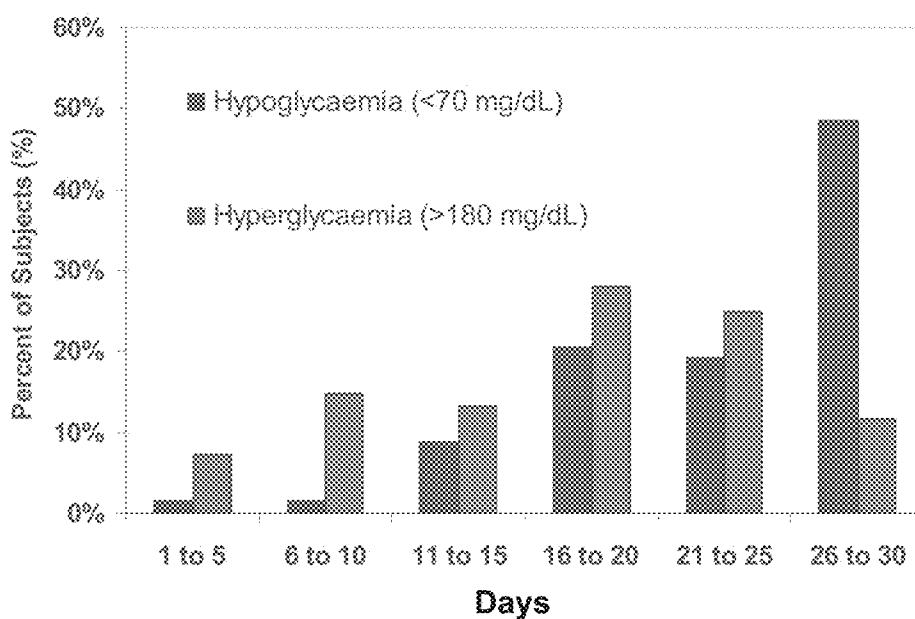

FIGURE 12

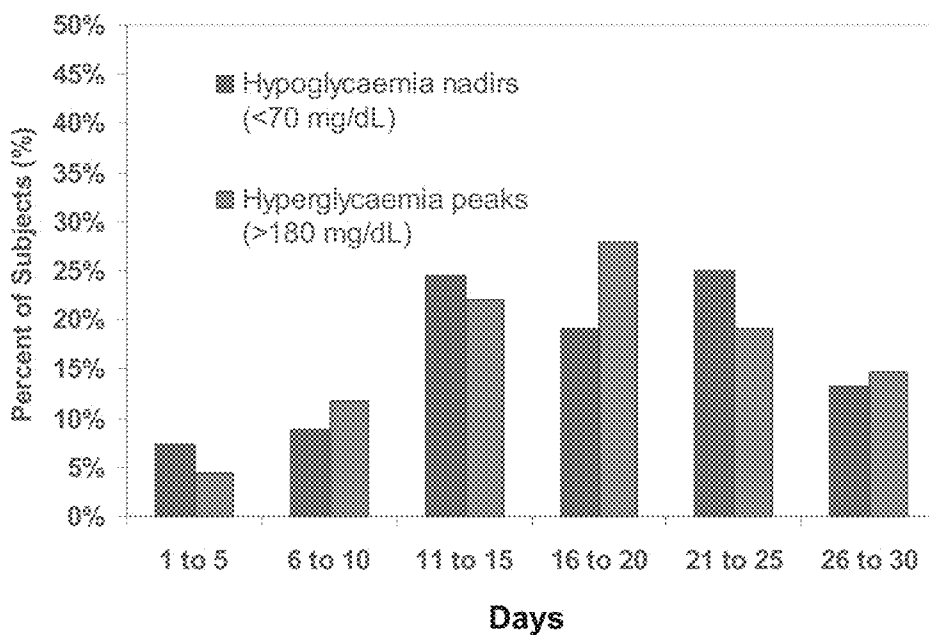

FIGURE 13

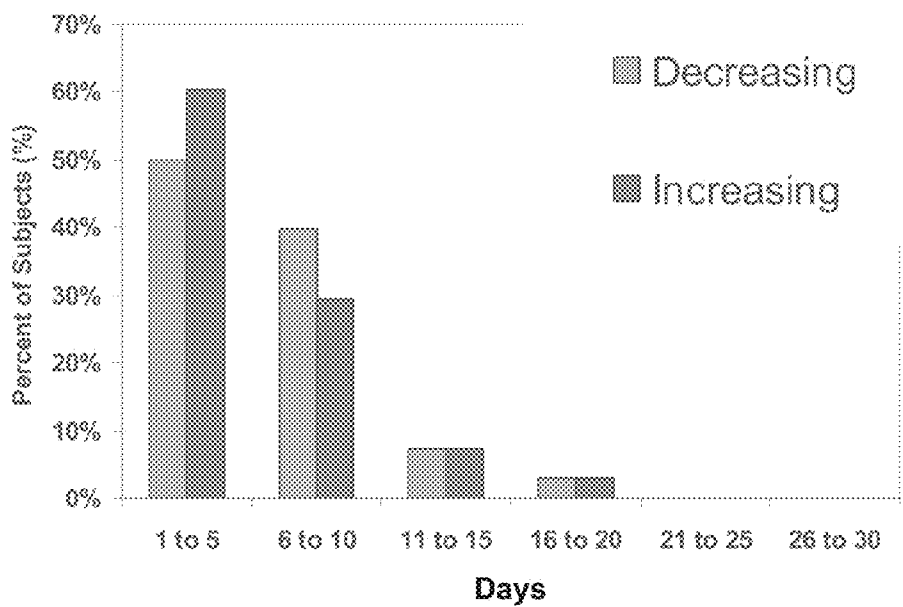

FIGURE 14

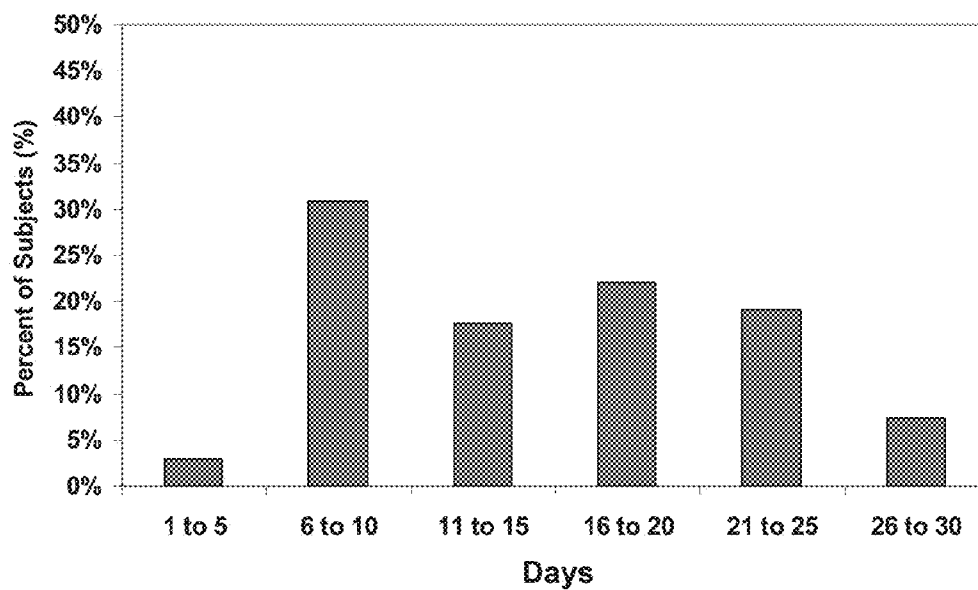

FIGURE 15

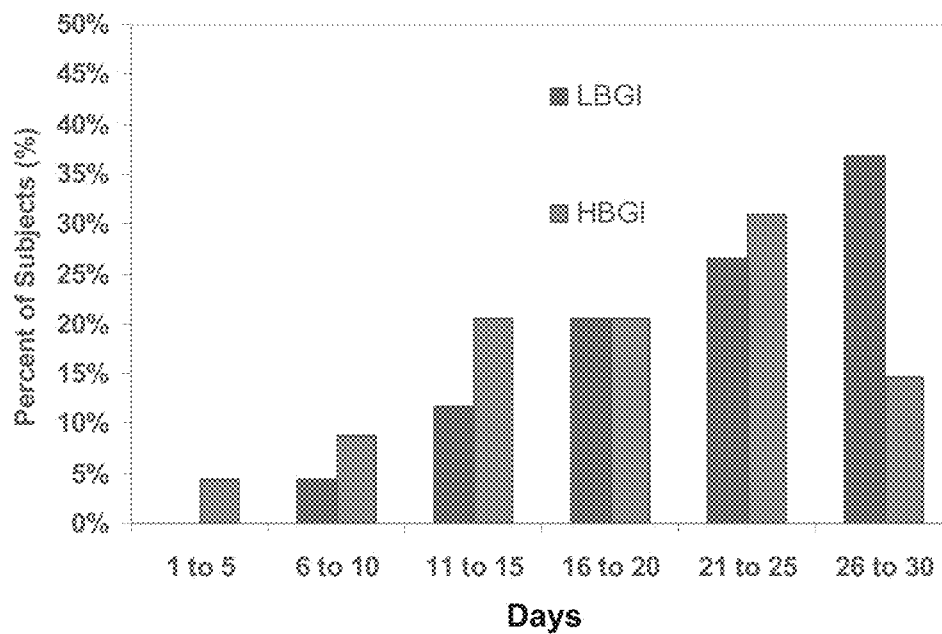

FIGURE 16

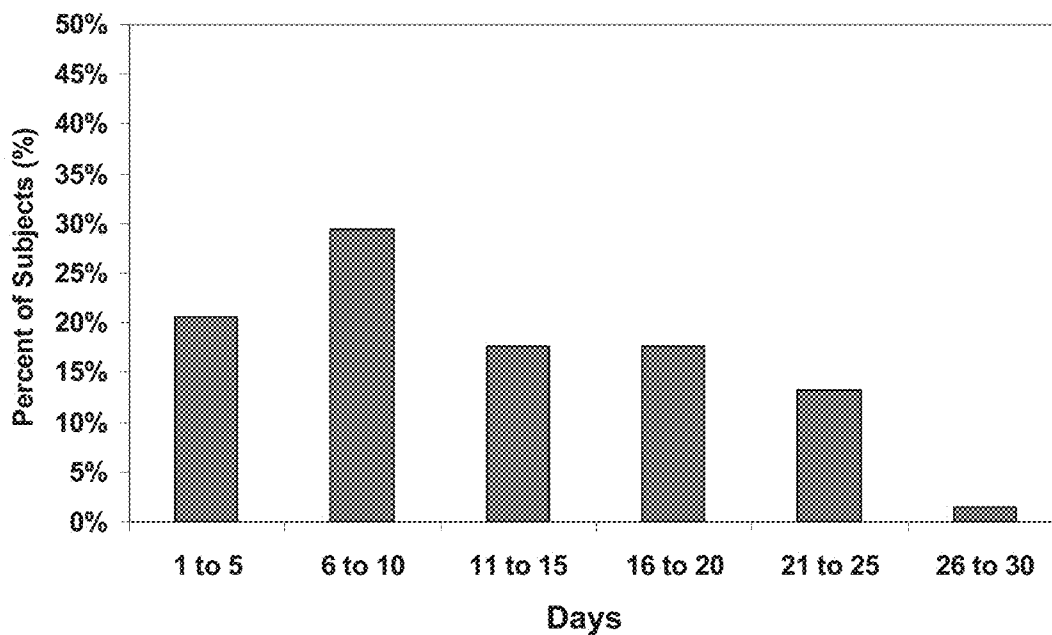

FIGURE 17

ASSESSING MEASURES OF GLYCEMIC VARIABILITY

RELATED APPLICATIONS

[0001] The present application is a continuation of U.S. patent application Ser. No. 13/854,005 filed Mar. 29, 2013, which is a continuation of U.S. patent application Ser. No. 12/257,353 filed Oct. 23, 2008, now U.S. Pat. No. 8,409,093, entitled "Assessing Measures of Glycemic Variability", which claims priority under 35 U.S.C. §119(e) to U.S. Provisional Application No. 60/982,110 filed Oct. 23, 2007, entitled "Assessing Measures Of Glycemic Variability", and assigned to the Assignee of the present application, Abbott Diabetes Care Inc. of Alameda, Calif., the disclosures of each of which are incorporated herein by reference for all purposes.

BACKGROUND

[0002] Analyte, e.g., glucose monitoring systems including continuous and discrete monitoring systems generally include a small, lightweight battery powered and microprocessor controlled system which is configured to detect signals proportional to the corresponding measured glucose levels using an electrometer, and RF signals to transmit the collected data. One aspect of certain analyte monitoring systems include a transcutaneous or subcutaneous analyte sensor configuration which is, for example, partially mounted on the skin of a subject whose analyte level is to be monitored. The sensor cell may use a two or three-electrode (work, reference and counter electrodes) configuration driven by a controlled potential (potentiostat) analog circuit connected through a contact system.

[0003] The analyte sensor may be configured so that at least a portion thereof is placed under the skin of the patient so as to detect the analyte levels of the patient. In embodiments in which a portion is below the skin and a portion is above, the portion above the skin may be directly or indirectly connected with the transmitter unit. The transmitter unit is configured to transmit the analyte levels, e.g., in the form of current, detected by the sensor over a wireless (or wired) communication link such as an RF (radio frequency) communication link to a receiver/monitor unit. The receiver/monitor unit performs data analysis, among others on the received analyte levels to generate information pertaining to the monitored analyte levels.

[0004] To obtain accurate data from the analyte sensor, calibration may be necessary. In certain instances, blood glucose measurements are periodically obtained using, for example, a conventional analyte test strip and blood glucose meter, and the measured blood glucose values are used to calibrate the sensors. Indeed, the patient may calibrate each new analyte sensor using for example, capillary blood glucose measurements. Due to a lag factor between the monitored data and the measured blood glucose values, an error may be introduced in the monitored data.

[0005] In view of the foregoing, it would be desirable to have a method and system for calibrating analyte sensors of an analyte monitoring system to account for such lag errors in analyte monitoring systems.

SUMMARY

[0006] In particular embodiments, methods, devices and systems for receiving an instruction to determine a glycemic

variation level, retrieving a stored metric for determining the glycemic variation level, retrieving one or more parameters associated with the retrieved metric analysis, determining the glycemic variation level based on the retrieved one or more parameters for the retrieved metric analysis, and outputting the determined glycemic variation level when it is determined that the retrieved one or more parameters associated with the retrieved metric analysis meets a predetermined condition are disclosed.

[0007] These and other objects, features and advantages of the present disclosure will become more fully apparent from the following detailed description of the embodiments, the appended claims and the accompanying drawings.

BRIEF DESCRIPTION OF THE DRAWINGS

[0008] FIG. 1 illustrates a block diagram of a data monitoring and management system for practicing one or more embodiments of the present disclosure;

[0009] FIG. 2 is a block diagram of the transmitter unit of the data monitoring and management system shown in FIG. 1 in accordance with one embodiment of the present disclosure;

[0010] FIG. 3 is a block diagram of the receiver/monitor unit of the data monitoring and management system shown in FIG. 1 in accordance with one embodiment of the present disclosure;

[0011] FIG. 4 is a flowchart illustrating glycemic variability determination in accordance with one aspect of the present disclosure;

[0012] FIG. 5 is a flowchart illustrating glycemic variability determination in accordance with another aspect of the present disclosure;

[0013] FIG. 6 shows a sample subject estimation of metric analysis based on MAGE with decreasing excursions in one aspect;

[0014] FIG. 7 shows a sample subject estimation of metric analysis based on GRADE in one aspect;

[0015] FIG. 8 illustrates the overall glucose variability measures and estimation requirements for the experimental study;

[0016] FIG. 9 illustrates the number of days of continuously monitored glucose data to attain the estimation requirement;

[0017] FIG. 10 illustrates the glucose standard deviation analysis as the metric for glycemic variability assessment;

[0018] FIG. 11 illustrates the proportion of time analysis (in hours per day—in hypoglycemia or hyperglycemia) as the metric for glycemic variability assessment;

[0019] FIG. 12 illustrates the number of episodes per day analysis (in hypoglycemia and hyperglycemia) as the metric for glycemic variability assessment;

[0020] FIG. 13 illustrates the maximum excursion analysis for each hypoglycemic episode or hyperglycemic episode as the metric for glycemic variability assessment;

[0021] FIG. 14 illustrates the results of MAGE analysis as the metric for glycemic variability assessment;

[0022] FIG. 15 illustrates the results of the Lability Index analysis as the metric for glycemic variability assessment;

[0023] FIG. 16 illustrates the results of Kovachev Risk Score analysis as the metric for glycemic variability assessment; and

[0024] FIG. 17 illustrates the results of GRADE analysis as the metric for glycemic variability assessment.

DETAILED DESCRIPTION

[0025] As described in further detail below, in accordance with the various embodiments of the present disclosure, there is provided a method and system for performing glycemic variability assessment based on one or more metric analysis to provide a snapshot of a diabetic condition based on continuously monitored glucose data over a predetermined time period.

[0026] FIG. 1 illustrates a data monitoring and management system such as, for example, analyte (e.g., glucose) monitoring system 100 in accordance with one embodiment of the present disclosure. The subject invention is further described primarily with respect to a glucose monitoring system for convenience and such description is in no way intended to limit the scope of the invention. It is to be understood that the analyte monitoring system may be configured to monitor a variety of analytes, e.g., lactate, and the like. For example, analytes that may be monitored include but are not limited to, for example, acetyl choline, amylase, bilirubin, cholesterol, chorionic gonadotropin, creatine kinase (e.g., CK-MB), creatine, DNA, fructosamine, glucose, glutamine, growth hormones, hormones, ketones, lactate, peroxide, prostate-specific antigen, prothrombin, RNA, thyroid stimulating hormone, and troponin. The concentration of drugs, such as, for example, antibiotics (e.g., gentamicin, vancomycin, and the like), digitoxin, digoxin, drugs of abuse, theophylline, and warfarin, may also be monitored.

[0027] The analyte monitoring system 100 includes a sensor 101, a transmitter unit 102 directly or indirectly coupled to the sensor 101, and a primary receiver unit 104 which is configured to communicate with the transmitter unit 102 via a communication link 103. The primary receiver unit 104 may be further configured to transmit data to a data processing terminal 105 for evaluating the data received by the primary receiver unit 104. Moreover, the data processing terminal in one embodiment may be configured to receive data directly from the transmitter unit 102 via a communication link 106 which may optionally be configured for bi-directional communication.

[0028] Also shown in FIG. 1 is an optional secondary receiver unit 106 which is operatively coupled to the communication link and configured to receive data transmitted from the transmitter unit 102. Moreover, as shown in the Figure, the secondary receiver unit 106 is configured to communicate with the primary receiver unit 104 as well as the data processing terminal 105. Indeed, the secondary receiver unit 106 may be configured for bi-directional wireless communication with each of the primary receiver unit 104 and the data processing terminal 105. As discussed in further detail below, in one embodiment of the present disclosure, the secondary receiver unit 106 may be configured to include a limited number of functions and features as compared with the primary receiver unit 104. As such, the secondary receiver unit 106 may be configured substantially in a smaller compact housing or embodied in a device such as a wrist watch, for example. Alternatively, the secondary receiver unit 106 may be configured with the same or substantially similar functionality as the primary receiver unit 104, and may be configured to be used in conjunction with a docking cradle unit for placement by bedside, for night time monitoring, and/or bi-directional communication device.

[0029] Only one sensor 101, transmitter unit 102, communication link 103, and data processing terminal 105 are shown in the embodiment of the analyte monitoring system 100

illustrated in FIG. 1. However, it will be appreciated by one of ordinary skill in the art that the analyte monitoring system 100 may include one or more sensor 101, transmitter unit 102, communication link 103, and data processing terminal 105. Moreover, within the scope of the present disclosure, the analyte monitoring system 100 may be a continuous, semi-continuous, or a discrete monitoring system. In a multi-component environment, each device is configured to be uniquely identified by each of the other devices in the system so that communication conflict is readily resolved between the various components within the analyte monitoring system 100.

[0030] In one embodiment of the present disclosure, the sensor 101 is physically positioned in or on the body of a user whose analyte level is being monitored. In one aspect, the sensor 101 may be configured to use one or more of coulometric, amperometric, potentiometric or conductometric approaches to measure the analyte level being monitored. The sensor 101 may be configured to continuously sample the analyte of the user and the sampled analyte may be converted into a corresponding data signal for transmission by the transmitter unit 102. In one embodiment, the transmitter unit 102 is mounted on the sensor 101 so that both devices are positioned on the user's body. The transmitter unit 102 performs data processing such as filtering and encoding on data signals, each of which corresponds to a sampled analyte level of the user, for transmission to the primary receiver unit 104 via the communication link 103.

[0031] In one embodiment, the analyte monitoring system 100 is configured as a one-way RF communication path from the transmitter unit 102 to the primary receiver unit 104. In such embodiment, the transmitter unit 102 may transmit the sampled data signals received from the sensor 101 without acknowledgement from the primary receiver unit 104 that the transmitted sampled data signals have been received (in other embodiments there may be acknowledgement). For example, the transmitter unit 102 may be configured to transmit the encoded sampled data signals at a fixed rate (e.g., at one minute intervals or other interval) after the completion of the initial power-on procedure. Likewise, the primary receiver unit 104 may be configured to detect such transmitted encoded sampled data signals at predetermined time intervals. Alternatively, the analyte monitoring system 100 may be configured with a bi-directional RF (or otherwise) communication between the transmitter unit 102 and the primary receiver unit 104.

[0032] Additionally, in one aspect, the primary receiver unit 104 may include two sections. The first section is an analog interface section that is configured to communicate with the transmitter unit 102 via the communication link 103. In one embodiment, the analog interface section may include a RF receiver and an antenna for receiving and amplifying the data signals from the transmitter unit 102, which are thereafter, demodulated with a local oscillator and filtered through a band-pass filter. The second section of the primary receiver unit 104 is a data processing section which is configured to process the data signals received from the transmitter unit 102 such as by performing data decoding, error detection and correction, data clock generation, and data bit recovery.

[0033] In operation in certain embodiments, upon completing a power-on procedure if required, the primary receiver unit 104 is configured to detect the presence of the transmitter unit 102 within its range based on, for example, the strength of the detected data signals received from the transmitter unit 102 or a predetermined transmitter identification informa-

tion. Upon successful synchronization with the corresponding transmitter unit **102**, the primary receiver unit **104** is configured to begin receiving from the transmitter unit **102** data signals corresponding to the user's detected analyte level. More specifically, the primary receiver unit **104** in one embodiment is configured to perform synchronized time hopping with the corresponding synchronized transmitter unit **102** via the communication link **103** to obtain the user's detected analyte level.

[0034] Referring again to FIG. 1, the data processing terminal **105** may include a personal computer, a portable computer such as a laptop or a handheld device (e.g., personal digital assistants (PDAs) telephone such as a cellular telephone), and the like, each of which may be configured for data communication with the receiver via a wired or a wireless connection. Additionally, the data processing terminal **105** may further be connected to a data network (not shown) for storing, retrieving and updating data corresponding to the detected analyte level of the user.

[0035] Within the scope of the present disclosure, the data processing terminal **105** may include an infusion device such as an insulin infusion pump or the like, which may be configured to administer a drug such as, for example insulin, to users, and which may be configured to communicate with the receiver unit **104** for receiving, among others, the measured analyte level. Alternatively, the receiver unit **104** may be configured to integrate an infusion device therein so that the receiver unit **104** is configured to administer insulin therapy to patients, for example, for administering and modifying basal profiles, as well as for determining appropriate boluses for administration based on, among others, the detected analyte levels received from the transmitter unit **102**.

[0036] Additionally, the transmitter unit **102**, the primary receiver unit **104** and the data processing terminal **105** may each be configured for bi-directional wireless communication such that each of the transmitter unit **102**, the primary receiver unit **104** and the data processing terminal **105** may be configured to communicate (that is, transmit data to and receive data from) with each other via the wireless communication link **103**. More specifically, the data processing terminal **105** may in one embodiment be configured to receive data directly from the transmitter unit **102** via the communication link **106**, where the communication link **106**, as described above, may be configured for bi-directional communication.

[0037] In this embodiment, the data processing terminal **105** which may include an insulin pump, may be configured to receive the analyte signals from the transmitter unit **102**, and thus, incorporate the functions of the receiver **104** including data processing for managing the patient's insulin therapy and analyte monitoring. In one embodiment, the communication link **103** may include one or more of an RF communication protocol, an infrared communication protocol, a Bluetooth® enabled communication protocol, an 802.11x wireless communication protocol, or an equivalent wireless communication protocol which would allow secure, wireless communication of several units (for example, per HIPAA requirements) while avoiding potential data collision and interference.

[0038] FIG. 2 is a block diagram of the transmitter of the data monitoring and detection system shown in FIG. 1 in accordance with one embodiment of the present disclosure. Referring to the Figure, the transmitter unit **102** in one embodiment includes an analog interface **201** configured to communicate with the sensor **101** (FIG. 1), a user input **202**,

and a temperature detection section **203**, each of which is operatively coupled to a transmitter processor **204** such as a central processing unit (CPU). As can be seen from FIG. 2, there are provided (this is very specific—what if more or less contacts—no guard, etc.) four contacts, three of which are electrodes—work electrode (W) **210**, guard contact (G) **211**, reference electrode (R) **212**, and counter electrode (C) **213**, each operatively coupled to the analog interface **201** of the transmitter unit **102** for connection to the sensor unit **201** (FIG. 1). In one embodiment, each of the work electrode (W) **210**, guard contact (G) **211**, reference electrode (R) **212**, and counter electrode (C) **213** may be made using a conductive material that may be applied in any suitable manner, e.g., printed or etched, for example, such as carbon, gold, and the like, which may be printed, or metal foil (e.g., gold) which may be etched.

[0039] Further shown in FIG. 2 are a transmitter serial communication section **205** and an RF transmitter **206**, each of which is also operatively coupled to the transmitter processor **204**. Moreover, a power supply **207** such as a battery is also provided in the transmitter unit **102** to provide the necessary power for the transmitter unit **102**. Additionally, as can be seen from the Figure, clock **208** is provided to, among others, supply real time information to the transmitter processor **204**.

[0040] In one embodiment, a unidirectional input path is established from the sensor **101** (FIG. 1) and/or manufacturing and testing equipment to the analog interface **201** of the transmitter unit **102**, while a unidirectional output is established from the output of the RF transmitter **206** of the transmitter unit **102** for transmission to the primary receiver unit **104**. In this manner, a data path is shown in FIG. 2 between the aforementioned unidirectional input and output via a dedicated link **209** from the analog interface **201** to serial communication section **205**, thereafter to the processor **204**, and then to the RF transmitter **206**. As such, in one embodiment, via the data path described above, the transmitter unit **102** is configured to transmit to the primary receiver unit **104** (FIG. 1), via the communication link **103** (FIG. 1), processed and encoded data signals received from the sensor **101** (FIG. 1). Additionally, the unidirectional communication data path between the analog interface **201** and the RF transmitter **206** discussed above allows for the configuration of the transmitter unit **102** for operation upon completion of the manufacturing process as well as for direct communication for diagnostic and testing purposes.

[0041] As discussed above, the transmitter processor **204** is configured to transmit control signals to the various sections of the transmitter unit **102** during the operation of the transmitter unit **102**. In one embodiment, the transmitter processor **204** also includes a memory (not shown) for storing data such as the identification information for the transmitter unit **102**, as well as the data signals received from the sensor **101**. The stored information may be retrieved and processed for transmission to the primary receiver unit **104** under the control of the transmitter processor **204**. Furthermore, the power supply **207** may include a commercially available battery.

[0042] The transmitter unit **102** is also configured such that the power supply section **207** is capable of providing power to the transmitter for a predetermined minimum continuous operation time period and also with a predetermined minimum shelf life time period such as, for example, a minimum of about three months of continuous operation after having been stored for about eighteen months in a low-power (non-

operating) mode. In one embodiment, this may be achieved by the transmitter processor 204 operating in low-power modes in the non-operating state, for example, drawing no more than approximately 1 μ A of current. Indeed, in one embodiment, the final step during the manufacturing process of the transmitter unit 102 may place the transmitter unit 102 in the low-power, non-operating state (i.e., post-manufacture sleep mode). In this manner, the shelf life of the transmitter unit 102 may be significantly improved. Moreover, as shown in FIG. 2, while the power supply unit 207 is shown as coupled to the processor 204, and as such, the processor 204 is configured to provide control of the power supply unit 207, it should be noted that within the scope of the present disclosure, the power supply unit 207 is configured to provide the necessary power to each of the components of the transmitter unit 102 shown in FIG. 2.

[0043] Referring back to FIG. 2, the power supply section 207 of the transmitter unit 102 in one embodiment may include a rechargeable battery unit that may be recharged by a separate power supply recharging unit (for example, provided in the receiver unit 104) so that the transmitter unit 102 may be powered for a longer period of usage time. Moreover, in one embodiment, the transmitter unit 102 may be configured without a battery in the power supply section 207, in which case the transmitter unit 102 may be configured to receive power from an external power supply source (for example, a battery) as discussed in further detail below.

[0044] Referring yet again to FIG. 2, the optional temperature detection section 203 of the transmitter unit 102 is configured to monitor the temperature of the skin near the sensor insertion site. The temperature reading may be used to adjust the analyte readings obtained from the analog interface 201. The RF transmitter 206 of the transmitter unit 102 may be configured for operation in the frequency band of 315 MHz to 433 MHz, for example, in the United States. Further, in one embodiment, the RF transmitter 206 is configured to modulate the carrier frequency by performing Frequency Shift Keying and Manchester encoding. In one embodiment, the data transmission rate is 19,200 symbols per second, with a minimum transmission range for communication with the primary receiver unit 104.

[0045] Referring yet again to FIG. 2, also shown is a leak detection circuit 214 coupled to the guard electrode (G) 211 and the processor 204 in the transmitter unit 102 of the data monitoring and management system 100. The leak detection circuit 214 in accordance with one embodiment of the present disclosure may be configured to detect leakage current in the sensor 101 to determine whether the measured sensor data are corrupt or whether the measured data from the sensor 101 is accurate.

[0046] FIG. 3 is a block diagram of the receiver/monitor unit of the data monitoring and management system shown in FIG. 1 in accordance with one embodiment of the present disclosure. Referring to FIG. 3, the primary receiver unit 104 includes a blood glucose test strip interface 301, an RF receiver 302, an input 303, a temperature detection section 304, and a clock 305, each of which is operatively coupled to a receiver processor 307. As can be further seen from the Figure, the primary receiver unit 104 also includes a power supply 306 operatively coupled to a power conversion and monitoring section 308. Further, the power conversion and monitoring section 308 is also coupled to the receiver processor 307. Moreover, also shown are a receiver serial commu-

nication section 309, and an output 310, each operatively coupled to the receiver processor 307.

[0047] In one embodiment, the test strip interface 301 includes a glucose level testing portion to receive a manual insertion of a glucose test strip, and thereby determine and display the glucose level of the test strip on the output 310 of the primary receiver unit 104. This manual testing of glucose can be used to calibrate sensor 101. The RF receiver 302 is configured to communicate, via the communication link 103 (FIG. 1) with the RF transmitter 206 of the transmitter unit 102 for, among others, signal mixing, demodulation, and other data processing. The input 303 of the primary receiver unit 104 is configured to allow the user to enter information into the primary receiver unit 104 as needed. In one aspect, the input 303 may include one or more keys of a keypad, a touch-sensitive screen, or a voice-activated input command unit. The temperature detection section 304 is configured to provide temperature information of the primary receiver unit 104 to the receiver processor 307, while the clock 305 provides, among others, real time information to the receiver processor 307.

[0048] Each of the various components of the primary receiver unit 104 shown in FIG. 3 is powered by the power supply 306 which, in one embodiment, includes a battery. Furthermore, the power conversion and monitoring section 308 is configured to monitor the power usage by the various components in the primary receiver unit 104 for effective power management and to alert the user, for example, in the event of power usage which renders the primary receiver unit 104 in sub-optimal operating conditions. An example of such sub-optimal operating condition may include, for example, operating the vibration output mode (as discussed below) for a period of time thus substantially draining the power supply 306 while the processor 307 (thus, the primary receiver unit 104) is turned on. Moreover, the power conversion and monitoring section 308 may additionally be configured to include a reverse polarity protection circuit such as a field effect transistor (FET) configured as a battery activated switch.

[0049] The serial communication section 309 in the primary receiver unit 104 is configured to provide a bi-directional communication path from the testing and/or manufacturing equipment for, among others, initialization, testing, and configuration of the primary receiver unit 104. Serial communication section 104 can also be used to upload data to a computer, such as time-stamped blood glucose data. The communication link with an external device (not shown) can be made, for example, by cable, infrared (IR) or RF link. The output 310 of the primary receiver unit 104 is configured to provide, among others, a graphical user interface (GUI) such as a liquid crystal display (LCD) for displaying information. Additionally, the output 310 may also include an integrated speaker for outputting audible signals as well as to provide vibration output as commonly found in handheld electronic devices, such as mobile telephones presently available. In a further embodiment, the primary receiver unit 104 also includes an electro-luminescent lamp configured to provide backlighting to the output 310 for output visual display in dark ambient surroundings.

[0050] Referring back to FIG. 3, the primary receiver unit 104 in one embodiment may also include a storage section such as a programmable, non-volatile memory device as part of the processor 307, or provided separately in the primary receiver unit 104, operatively coupled to the processor 307.

The processor **307** may be configured to perform Manchester decoding as well as error detection and correction upon the encoded data signals received from the transmitter unit **102** via the communication link **103**.

[0051] Additional detailed description of the continuous analyte monitoring system, its various components including descriptions of the transmitter, the receiver/display unit, data communication, calibration and sensor insertion, among others, are provided in U.S. Pat. No. 6,175,752 issued Jan. 16, 2001 entitled “Analyte Monitoring Device and Methods of Use”, and in application Ser. No. 10/745,878 filed Dec. 26, 2003 entitled “Continuous Glucose Monitoring System and Methods of Use”, each assigned to the Assignee of the present application, disclosure of each of which are incorporated herein by reference for all purposes.

[0052] In aspects of the present disclosure, a robust glycemic variability determination function is provided. In particular, in one aspect, based on the analyte data collected over a predetermined time period, glycemic variability may be determined using one or more defined metrics for analysis to provide, for example, a diabetic condition of a patient or a user of the analyte monitoring system at any given time. In one aspect, one or more metrics such as standard deviation analysis, proportion of time (for example, hours per day) analysis, number of episodes per day analysis, maximum excursion during episode analysis (for example, measured in mg/dL), Mean Amplitude of Glycemic Excursions (MAGE) analysis, Lability Index analysis, Kovatchev Risk Score (based, for example, on low/high glucose index), or Glycemic Risk Assessment Diabetes Equation (GRADE) analysis, may be used to determine glycemic variability based on continuously monitored glucose data received and stored from the analyte sensor **101**, for example, by the processing and storage unit **307** of the receiver unit **104/105** (FIG. 1).

[0053] The determined glycemic variability information may be output to the user or the patient at the output/display unit **310** of the receiver unit **104/105** to provide, for example, a snapshot of the diabetic condition of the analyte monitoring system user or patient based on glucose data received from the analyte sensor **101**. In this manner, a user or a patient may conveniently track or monitor his/her diabetic condition when sufficient glucose data has been received from the sensor.

[0054] FIG. 4 is a flowchart illustrating glycemic variability determination in accordance with one aspect of the present disclosure. Referring to FIG. 4, when the receiver unit **104/105** detects a request for glycemic variability determination (**410**), one or more available metrics for determining glycemic variability information is retrieved (**420**), and presented to the user/patient (for example, on the output/display **310** of the receiver unit **104/105**). Upon receiving an indication selecting one or more of the available metrics for glycemic variability determination (**430**), one or more parameters associated the selected metric for glycemic variability determination is retrieved (**440**). For example, in one aspect, when standard deviation analysis is selected as the metric for determining the glycemic variability information, the associated number of glucose data points for determining the glycemic variability information using the standard deviation analysis is retrieved. For example, in one aspect, the standard deviation analysis may be configured to require 50 days of glucose data points to provide an accurate glycemic variability information.

[0055] Referring to FIG. 4, as shown, it is determined whether the retrieved parameter meets the selected metric

threshold (**450**). That is, in one aspect, the processing and storage unit **307** of the receiver unit **104/105** may be configured to retrieve stored glucose data points for the past 50 days. When the glucose data points for performing the selected metric analysis is determined to be sufficient (i.e., the receiver unit **104/105** has glucose data points for at least the past prior 50 days), then the glycemic variability is determined based on the selected metric analysis and presented to the user or the patient, for example, output to the output/display **310** on the receiver unit **104/105** (**460**). On the other hand, if the retrieved parameter does not meet the selected metric threshold (**450**) (that is, there are less than 50 days of glucose data points available for the selected metric analysis), a failure notification is generated and output to the user or the patient (**470**).

[0056] As described above, in one aspect, depending upon the selected metric for glycemic variability determination, when the parameters associated with the selected metric is available (for example, the needed pool of glucose data points spanning a predetermined time period which may be programmed in the receiver unit **104/105**), the user or the patient may be provided with a reliable and accurate information of the monitored diabetic condition. In one aspect, the parameters for each metric made available to the user or the patient for determining glycemic variability may be based on a pre-programmed threshold level for each metric to provide an acceptable accuracy level, and which may be adjusted or modified.

[0057] In a further aspect, the user input unit **303** (FIG. 3) of the receiver unit **104/105** may be provided with a dedicated button or selectable indicator for the glycemic variability determination. For example, a “hot key” may be assigned in a menu structure presented in the output/display **310** to provide user selectability of the glycemic variability function. In this manner, in addition to receiving real time monitored glucose information from the analyte monitoring system **100** (FIG. 1), a user or a patient may readily, easily, and accurately determine his/her glycemic variability. In yet a further aspect, the glycemic variability may be performed retrospectively at a remote terminal such as the data processing terminal **105** which may include a personal computer or a server terminal that has received and stored the monitored glucose data points.

[0058] FIG. 5 is a flowchart illustrating glycemic variability determination in accordance with another aspect of the present disclosure. Referring to FIG. 5, when a request for glycemic variability information is received (**510**), the stored analyte data over a predetermined time period for the metric to determine glycemic variability is retrieved (**520**). Based on the retrieved analyte data, the glycemic variability is assessed using the metric, for example, programmed or associated with the glycemic variability determination function (**530**).

[0059] Thereafter, the determined glycemic variability information is generated (**540**) and then output to the user or the patient (**550**). That is, in one aspect, when a user, a patient or a healthcare provider wishes to view a snapshot of the user or patient’s diabetic condition, the receiver unit **104/105** may be configured to perform glycemic variability determination based on pre-programmed metric. In one aspect, the pre-programmed metric may be changed or varied as a user configurable parameter. In addition, the parameters associated with the pre-programmed metric may be user configurable or varied by, for example, the user, the patient or the healthcare provider.

Experimental Results

[0060] The FreeStyle Navigator® Continuous Glucose Monitoring System was used continuously for at least 70 days by ninety subjects. One-minute glucose data over this time period were collected from each subject, and data for the initial 20 days were excluded from the variability assessment as not representative of the overall subject glucose variability. The analyte sensor was replaced every 5 days with a new sensor, and calibration of each sensor at the scheduled calibration times were performed, for example, using an in vitro blood glucose meter. Eight glycemic variability metrics were calculated for each study subject. A defined estimation accuracy requirement was predetermined and imposed in the study to set the number of days of continuously monitored data needed for each metric determination.

[0061] The eight glycemic variability assessment metrics included standard deviation analysis, proportion of time (for example, hours per day) analysis, number of episodes per day analysis, maximum excursion during episode analysis (for example, measured in mg/dL), Mean Amplitude of Glycemic Excursions (MAGE) analysis, Lablity Index analysis, Kovatchev Risk Score (based, for example, on low/high glucose index), and Glycemic Risk Assessment Diabetes Equation (GRADE) analysis.

[0062] Based on subject analysis eligibility of more than 50 days of continuously monitored glucose data, 68 of the 90 subjects were eligible. For each subject, the true parameter value for each metric analysis was based on the value of the subject's glucose data after 50 days from the start of the continuous monitoring. The cumulative subject value for the metric analysis was defined daily based on all cumulative data for each day, where an acceptable parameter estimate was defined at cumulative value within $\pm 10\%$ of the true parameter value. Also, the optimal days of continuously monitored glucose data to acceptable accuracy was defined for each subject as the first day at which the cumulative value remained within $\pm 10\%$ of the subject's true parameter value.

[0063] FIG. 6 shows a sample subject estimation of metric analysis based on MAGE with decreasing excursions, with a standard deviation factor of 1.0 based on continuous glucose data collected over a time period of approximately 35 days after the initial 120 day period. FIG. 7 shows a sample subject estimation of metric analysis based on GRADE using continuously monitored glucose data over a time period of approximately 30 days after the initial 20 day period, showing the mean, standard deviation and the standard error.

[0064] FIG. 8 illustrates the overall glucose variability measures and estimation requirements for the study based on 90 subjects for each of the eight metric analysis performed. FIG. 9 illustrates the number of days of continuously monitored glucose data to attain the estimation requirement of 10% with the exclusion of data from the initial 20 day period for each of the eight metrics discussed above. FIGS. 10-17 illustrate the results of each of the eight metric analysis, respectively, over the time period of approximately 30 days after the initial 20 day period for glycemic variability assessment.

[0065] For example, FIG. 10 illustrates the glucose standard deviation analysis as the metric for glycemic variability assessment, FIG. 11 illustrates the proportion of time analysis (in hours per day—in hypoglycemia or hyperglycemia) as the metric for glycemic variability assessment, FIG. 12 illustrates the number of episodes per day analysis (in hypoglycemia

and hyperglycemia) as the metric for glycemic variability assessment, FIG. 13 illustrates the maximum excursion analysis for each hypoglycemic episode or hyperglycemic episode as the metric for glycemic variability assessment, FIG. 14 illustrates the results of MAGE analysis as the metric for glycemic variability assessment, FIG. 15 illustrates the results of the Lablity Index analysis as the metric for glycemic variability assessment, FIG. 16 illustrates the results of Kovatchev Risk Score analysis as the metric for glycemic variability assessment showing low blood glucose index (LBGI) and high blood glucose index (HBGI), and FIG. 17 illustrates the results of GRADE analysis as the metric for glycemic variability assessment, each of these figures based on data collected from the subjects over the 30 day time period of continuous glucose monitoring.

[0066] In the manner described, in embodiments of the present disclosure, depending upon the metric analysis used for glycemic variability assessment, to achieve the desired accuracy level, the amount of continuously monitored data may vary. Accordingly, one or more parameters such as the number of days of available continuous glucose data for determining glycemic variability based on a selected or pre-programmed metric analysis may be modified or adjusted to achieve the desired accuracy level of glycemic variability level.

[0067] As discussed, within the scope of the present disclosure, the particular metric analysis (and/or associated parameters) for performing the glycemic variability assessment to illustrate a snapshot of a persons' diabetic condition may be defined or selected by the user, patient or the healthcare provider, or pre-programmed into the system (for example, the receiver unit 104/105, a computing device or computing terminal, a mobile telephone, a personal digital assistant, each configured to execute instructions to perform the metric analysis). Further, the device or system may be programmed such that when the underlying data available for the selected metric analysis is insufficient (for example, when there is not enough collected glucose data from the analyte monitoring device), the glycemic assessment analysis may be disabled or the user, patient, or the healthcare provider may be notified that there is insufficient data pool (or one or more conditions for one or more metrics to determine the glycemic variability are not satisfied).

[0068] An apparatus in one aspect includes a memory configured to store one or more executable instructions, a control unit operatively coupled to the memory and configured to retrieve the one or more executable instructions for execution, an input unit operatively coupled to the control unit for inputting one or more instructions to the control unit to execute one or more routines, and an output unit operatively coupled to the control unit for outputting one or more information, the output unit including a glycemic variability indicator associated with a determined variation in a glycemic level, where the glycemic variability indicator is provided to the output unit when the glycemic variation data is determined to be sufficient for a selected one or more metric to determine glycemic variability.

[0069] The control unit in one aspect may include one or more of a microprocessor, an application specific integrated circuit, or a state machine.

[0070] The one or more metric may include one or more of a standard deviation, MAGE, GRADE, Lablity index, a number of glycemic variation episode excursions, a duration

of each glycemic variation episode excursion, an average maximum excursion value, or a low/high blood glucose index.

[0071] Also, the one or more glycemic variation episode excursion may include deviation from a predetermined hypoglycemic threshold parameter or from a predetermined hyperglycemic threshold parameter.

[0072] Further, each of the one or more metrics may include a predetermined amount of data associated with the metric for glycemic variability determination.

[0073] In a further aspect, glycemic variability indicator may be provided to the output unit only when the glycemic variation data is determined to be sufficient.

[0074] The glycemic variation data may include a number of glucose data samples. Also, the number of glucose data samples may be stored in the memory unit.

[0075] The apparatus may include a communication unit operatively coupled to the control unit, the communication unit configured to send or receive data to or from a remote location, and further, where the remote location may include one or more of a remote data processing terminal, an analyte monitoring system, a blood glucose meter device, a server terminal, a personal digital assistant, a mobile telephone, or a messaging device.

[0076] The communication unit may be configured for wired or wireless communication.

[0077] A method in one aspect may include receiving an instruction to determine a glycemic variation level, retrieving a stored metric for determining the glycemic variation level, retrieving one or more parameters associated with the retrieved metric analysis, determining the glycemic variation level based on the retrieved one or more parameters for the retrieved metric analysis, and outputting the determined glycemic variation level when it is determined that the retrieved one or more parameters associated with the retrieved metric analysis meets a predetermined condition.

[0078] The predetermined condition may include a predetermined stabilization level.

[0079] The determined glycemic variation level may be output only when it is determined that the retrieved one or more parameters meets the predetermined condition.

[0080] The predetermined condition may include availability of the number of glucose data over a predetermined time period.

[0081] The predetermined time period may be associated with the retrieved metric analysis.

[0082] Also, the glycemic variation level may be output as one or more of an audible indication, a visual indication, a vibratory indication, or one or more combinations thereof.

[0083] The method may also include storing the determined glycemic variation level.

[0084] Additionally, the method may include outputting an indication of unsuccessful glycemic variation level when it is determined that the retrieved one or more parameters associated with the retrieved metric analysis does not meet the predetermined condition.

[0085] Again, the one or more metric analysis may include one or more of a standard deviation analysis, MAGE analysis, GRADE analysis, Lability index analysis, a number of glycemic variation episode excursions analysis, a duration of each glycemic variation episode excursion analysis, an average maximum excursion value analysis, or a low/high blood glucose index analysis.

[0086] An apparatus in a further aspect of the present disclosure may include a storage unit for storing one or more executable instructions, a microprocessor operatively coupled to the storage unit for accessing the one or more executable instructions, which, when executed receives an instruction to determine a glycemic variation level, retrieves a stored metric for determining the glycemic variation level, retrieves one or more parameters associated with the retrieved metric analysis, determines the glycemic variation level based on the retrieved one or more parameters for the retrieved metric analysis, and outputs the determined glycemic variation level when it is determined that the retrieved one or more parameters associated with the retrieved metric analysis meets a predetermined condition.

[0087] In some embodiments, a method is provided comprising receiving an instruction to determine a glycemic variation level associated with a glycemic variation metric, retrieving one or more parameters associated with the glycemic variation metric, retrieving stored glycemic data based on the one or more retrieved parameters, determining if the retrieved glycemic data meets one or more predetermined conditions based on the one or more parameters associated with the glycemic variation metric, determining the glycemic variation level associated with the glycemic variation metric based on the retrieved one or more parameters and the retrieved glycemic data, when it is determined that the one or more predetermined conditions are met, outputting the determined glycemic variation level, and outputting a notification when it is determined that the one or more predetermined conditions are not met.

[0088] Certain aspects include that the parameters associated with the glycemic variation metric include a value for a predetermined time period.

[0089] Certain aspects include that the parameters associated with the glycemic variation metric include a value for a minimum number of glucose data over a predetermined time period.

[0090] Certain aspects include that the parameters associated with the glycemic variation metric include a value for a minimum number of days with available glucose data within a predetermined time period.

[0091] Certain aspects include that the determined glycemic variation level is output as one or more of an audible indication, a visual indication, a vibratory indication, or one or more combinations thereof.

[0092] Certain aspects include that the determined glycemic variation level is output as a graphical representation of glycemic variation over time.

[0093] Certain aspects include that the notification is output as one or more of an audible indication, a visual indication, a vibratory indication, or one or more combinations thereof.

[0094] Certain aspects include storing the determined glycemic variation level.

[0095] Certain aspects include that the glycemic variation metric includes one or more of a standard deviation analysis, Mean Amplitude of Glycemic Excursions (MAGE) analysis, Glycemic Risk Assessment Diabetes Excursion (GRADE) analysis, Lability index analysis, a number of glycemic variation episode excursions analysis, a duration of each glycemic variation episode excursion analysis, an average maximum excursion value analysis, or a low/high blood glucose index analysis.

[0096] In some embodiments, an apparatus is provided comprising one or more processing units, and a memory for

storing instructions which, when executed by the one or more processing units, causes the one or more processing units to receive an instruction to determine a glycemic variation level associated with a glycemic variation metric, to retrieve one or more parameters associated with the glycemic variation metric, to retrieve stored glycemic data based on the one or more retrieved parameters, to determine if the retrieved glycemic data meets one or more predetermined conditions based on the one or more parameters associated with the glycemic variation metric, to determine the glycemic variation level associated with the glycemic variation metric based on the retrieved one or more parameters and the retrieved glycemic data, when it is determined that the one or more predetermined conditions are met, to output the determined glycemic variation level, and to output a notification when it is determined that the one or more predetermined conditions are not met.

[0097] Certain aspects include that the parameters associated with the glycemic variation metric include a value for a predetermined time period.

[0098] Certain aspects include that the parameters associated with the glycemic variation metric include a value for a minimum number of glucose data over a predetermined time period.

[0099] Certain aspects include that the parameters associated with the glycemic variation metric include a value for a minimum number of days with available glucose data within a predetermined time period.

[0100] Certain aspects include that the determined glycemic variation level is output as one or more of an audible indication, a visual indication, a vibratory indication, or one or more combinations thereof.

[0101] Certain aspects include that the determined glycemic variation level is output as a graphical representation of glycemic variation over time.

[0102] Certain aspects include that the notification is output as one or more of an audible indication, a visual indication, a vibratory indication, or one or more combinations thereof.

[0103] Certain aspects include that the memory for storing instructions which, when executed by the one or more processing units, further causes the one or more processing units to store the determined glycemic variation level.

[0104] Certain aspects include that the glycemic variation metric includes one or more of a standard deviation analysis, Mean Amplitude of Glycemic Excursions (MAGE) analysis, Glycemic Risk Assessment Diabetes Excursion (GRADE) analysis, Lability index analysis, a number of glycemic variation episode excursions analysis, a duration of each glycemic variation episode excursion analysis, an average maximum excursion value analysis, or a low/high blood glucose index analysis.

[0105] In some embodiments a method is provided comprising receiving an instruction to determine a glycemic variation level associated with a glycemic variation metric, retrieving one or more parameters associated with the glycemic variation metric, retrieving stored glycemic data based on the one or more retrieved parameters, determining if the retrieved glycemic data meets one or more predetermined conditions based on the one or more parameters associated with the glycemic variation metric, determining the glycemic variation level associated with the glycemic variation metric based on the retrieved one or more parameters and the retrieved glycemic data, when it is determined that the one or more predetermined conditions are met, and outputting a notification when it is determined that the one or more predetermined conditions are not met.

[0106] Various other modifications and alterations in the structure and method of operation of this invention will be apparent to those skilled in the art without departing from the scope and spirit of the invention. Although the invention has been described in connection with specific preferred embodiments, it should be understood that the invention as claimed should not be unduly limited to such specific embodiments. It is intended that the following claims define the scope of the present disclosure and that structures and methods within the scope of these claims and their equivalents be covered thereby.

1. (canceled)
2. A computer-implemented method comprising:
 - generating glucose sensor data indicative of a host's glucose concentration using a glucose sensor;
 - calculating a glycemic variability index value based on the glucose sensor data; and
 - providing output to a user responsive to the calculated glycemic variability index value.
3. The method of claim 2, wherein the providing output comprises generating a report to a user, wherein the report includes a calculated GVI numerical value.
4. The method of claim 2, wherein the providing output comprises triggering an alert to a user when the GVI exceeds a predetermined threshold, wherein the alert is one or more of an audible alert, visual alert and tactile alert.
5. The method of claim 2, wherein the calculating is automatically performed periodically on a defined window of time of sensor data.
6. The method of claim 2, wherein the calculating comprising calculating a plurality of GVI values based on the sensor data, wherein each of the GVI values is based on a different period of time of the sensor data.
7. The method of claim 2, wherein the method is performed by a processor executing code embodied in a non-transitory computer-readable medium.

* * * * *